

Lista e eksperteve te perfshire

Emri	Pozicioni
Angelo Iorio	Ekspert Topograf

Angelo Iorio

C. Giannakopoulou

Angelo Iorio

Massimiliano Giacobbi

R01	Tetor 2017	Projekti i Aprovuar	Christina Giannakopoulou	Angelo Iorio	Massimiliano Giacobbi
Rishikim	Data	Pershkrimi	Pergatiti	Kontrolloi	Aprovoi

Tabela e Permbajtjes

1	HYRJE	5
2	ZONA GJEOGRAFIKE	6
3	POLYGONAL BENCHMARKS	7
3.1	<i>Ndertimi i Stacioneve topografike</i>	7
3.2	<i>Rilevimi i Stacioneve Topografike me GPS</i>	7
3.3	<i>Prodhimi I hartes dixhitale</i>	9
4	LIST OF BENCHMARKS' (BM) COORDINATES	10
5	MONOGRAFIA E STACIONEVE TOPOGRAFIKE	14

List of Figures

Figura 1- B 1 a	14
Figura 2- B 1 b	15
Figura 3- B 2	15
Figura 4- B 4	16
Figura 5 - B 4 b	17
Figura 6 - B 6	17
Figura 7- B 6 b	18
Figura 8 - B 10, B 11	18
Figura 9 - B 12 a	19
Figura 10 - B 12 b	19
Figura 11- B 21	20
Figura 12- B 35	21
Figura 13- B 36	22
Figura 14- ST2	23
Figura 15- ST 19	24
Figura 16- B 100	25
Figura 17- B 101	26
Figura 18- B 102 A	27
Figura 19- B 127	28
Figura 20- B 103	29
Figura 21- B 104	30
Figura 22- B 126	31
Figura 23- B 105	32
Figura 24- B 107	33
Figura 25- B 106	34
Figura 26- B 108	35
Figura 27- B 125	36
Figura 28- B 109	37
Figura 29- B 110	38
Figura 30- B 111	39
Figura 31- B 10050	40
Figura 32- B 112	41

Figura 33- B 124.....	42
Figura 34- B 113.....	43
Figura 35- B 114.....	44
Figura 36- B 116.....	45
Figura 37- B 115.....	46
Figura 38- B 117.....	47
Figura 39- B 118.....	48
Figura 40- B 119.....	49
Figura 41- B 123.....	50
Figura 42- B 120.....	51
Figura 43- B 121.....	52
Figura 44- B 122.....	53
Figura 45- B 158.....	54
Figura 46- B 157.....	55
Figura 47- B 128.....	56
Figura 48- B 129.....	57
Figura 49- BM 80	58
Figura 50- B 130.....	59
Figura 51- B 156.....	60
Figura 52- B 131.....	61
Figura 53- B 155.....	62
Figura 54- B 132.....	63
Figura 55- B 133.....	64
Figura 56- B 154.....	65
Figura 57- B 134, B 203.....	66
Figura 58- B 135.....	67
Figura 59- B 152.....	68
Figura 60- B 136.....	69
Figura 61- B 151.....	70
Figura 62- B 137.....	71
Figura 63- B 138.....	72
Figura 64- B 150.....	73
Figura 65- B 139.....	74
Figura 66- B 149.....	75
Figura 67- B 140.....	76
Figura 68- B 148.....	77
Figura 69- B 141.....	78
Figura 70- B 147.....	79
Figura 71- B 142.....	80
Figura 72- B 146.....	81
Figura 73- B 145.....	82
Figura 74- B 144.....	83
Figura 75- B 143.....	84
Figura 76- B 160.....	85
Figura 77- B 161.....	86
Figura 78- B 162.....	87
Figura 79- B 163.....	88
Figura 80- B 164.....	89
Figura 81- B 165.....	90

Figura 82- B 201, B 202 91

List of Tables

Tabela 1 – Koordinatat e Stacioneve Topografike 13

1 HYRJE

Ky Raport pershkruan Rilevimi Topografik te realizuar per pergatitjen e Zgjerimit te Autostrades Tirane – Durres.

Punimet gjeodezike dhe topografike per projektine Superstrades “Tirane – Durres” jane kryer ne baze te kerkesave teknike te pergjithshme dhe specifikimeve te siguruara nga Autoriteti Kontraktor.

Studimi eshte kryer nga GEO-NORD Sh.p.k dhe Geosat Group Ltd.

GEO-NORD Sh.p.k ka rilevimin topografik te fazes se pare ne Shtator, Tetor 2015. Ne Janar 2016 eshte kryer rilevimi per rruget sekondare dhe me bashkepunimin e inxhinierëve strukturiste u procedua me te gjitha rilevimet e detajuara te veprave te medha per te vijuar me pas me Projekt Zbatimin e strukturave.

Geosat Group Ltd kreuurvejimet topografike shtese te fazes se dyte te projektit ne Shtator 2016, te cilat perfshinin zonat e kerkuara per rilevim topografik te rrugeve sekondare dhe nyjeve ne disnivel te projektit.

Ne Mars 2017, Konsulenti kreu rilevimet topografike te fundit te te gjithë veprave hidraulike. Resultatet e ketij rilevimi gjenden bashkelidhur Raportit Hidrologjik-Hidraulik te Projektit Final.

Perpara fillimit te aktivitetëve topografike jane siguruar materialet e nevojshme te hartave, gjeodezike dhe pajisjet perkatese.

Zona nen studim perfaqeson nje nga arteriet kryesore te infrastruktures ne vend, e cila mbledh volume te larta trafiku.

Rilevimet topografike u realizuan nga Konsulenti gjate muajve Shtator dhe Tetor 2015, se bashku me disa detaje te mbledhura gjate muajit Nentor dhe ne fillim te muajit Janar 2016.

2 ZONA GJEOGRAFIKE

Zona ne studim per projektin ndodhet ndermjet zones urbane te Tiranes dhe qytetit bregdetar te Durresit. Gjatesia totale e rruges eshte rreth 31km, dhe gjate studimit u mblodh informacion per nje distance mesatare prej 60 – 80m ne cdo ane per aksin ekzistues rrugor.

Gjate fazes se ndertimit, per shkat te zhvillimit te detajuar te Projektit, Konsulenti ka kryer anketime te tjera topografike. Gjate muajit Janar 2017 eshte kryer nje rilevim i ri topografik per 12 zona, pjese e rrugeve sekondare te perfshira. Zona perkatese eshte rreth 24 Ha.

Gjithashtu, per shkak te projektimit te tombinove, gjate muajit Mars 2017 eshte kryer Rilevimi Topografik per pjesen me te madhe te tombinove hidraulike ekzistuese pergjate rruges Tirane-Durres.

Kompania qe ka kryer kete Rilevim Topografik eshte Geosat Group Ltd.

Te gjitha Rilevimet Topografike jane perfshire ne “Planimetrine Ekzistuese” dhe kuotat e hyrje/daljes te tombinove jane perfshire ne tabelen e “Lista e Strukturave”

3 POLYGONAL BENCHMARKS

Poligoni i Stacioneve Topografike eshte marr i tille qe te krijoje nje harte dixhitale qe perfshin zonen pergjate aksit te propozuar te rruges se re, qe do te perdoret per qellime projektimi. Ky Poligon i Stacioneve Topografike (sistemuar pergjate gjithë linjes) deo te perdoret si reference pergjate implementimit te punimeve te ndertimit.

Rilevimi u realizua duke perdorur sistemin nderkombetar UTM, me elipsoid WGS84. Permes ketij sistemi, koordinatat gjeodete mund te identifikohen lehtesisht per cdo pike interesi ne siperfaqen e tokes bazuar ne te dhenat GPS.

Stacionet jane vendosur ne afersi te aksit rrugor te materializuar ne fushe prej celiku dhe betoni. Punimet topografike konsistojne ne hapat e meposhtem:

- Ndertimi i 85 stacioneve.
- Matja me GPS ne te gjithë Stacionet Topografike.
- Rilevimi i detajuar per gjithë gjatesine e projektit (per nje rrip me gjeresi 100 m).
- Krijimi i hartes dixhitale.

3.1 Ndertimi i Stacioneve topografike

Stacionet topografike jane ndertuar 300-500m larg njeri-tjetrit. Keto te fundit jane ndertuar duke perdorur shufra hekuri me gjatesi 70cm dhe diameter $\varnothing 12$ te montuara ne blloqe betoni 40x40cm dhe 60cm te thella.

Stacionet e tjera jane vendosur ne Ura, mure betoni, tombino box, dysHEME me materiale betoni, te fiksuara mire ne beton.

Ndertimi i tyre eshte bere ne vende ku te sigurohet jetegjatesia me e madhe e mundshme, ne menyre qe te ruhen per ndertimin e rruges se re.

Te gjitha Stacionet Topografike jane lyer me boje te kuqe, qe te jene qarte te dukshme. Per cdo pike, eshte vizatuar pozicioni fiks, duke e identifikuar ate ne lidhje me objekte fikse dhe duke e lidhur me file-t dixhitale, qe perfaqesojne monografine e pikave poligonale.

3.2 Rilevimi i Stacioneve Topografike me GPS

To obtain a good and precise field survey, it has been realized a network of benchmarks. We used the measurement method of the mini triangulations, measuring the GPS stations through the "Faststatic" method. Each point was measured with GPS from 20-30 min, taking into account the number of satellites at the time of measurement. After the GPS measurement, data is processed with Trimble Business Center.

We used "TRIMBLE R6 MODEL 3 GPS" dual frequency by TRIMBLE for the surveys, and "Trimble Business Center" post-processing software. These instruments represent some of the best technologies on market. Their technical specification for static survey is:

In order to make a detailed survey were involved group of works composed by 8 engineers and 4 workers. Data acquisition were made with the auxiliou of TRIMBLE R6 MODEL 3 GPS double frequencies and the software Trimble Business Center. The technical specifications of this instrument for the "Real Time Kinematic" are as below:

Te gjitha Rilevimet e Stacioneve Topografike me GPS jane kryer duke perdorur "GPS Dual Frequency receivers".

Per te marre nje Rilevim te mire dhe te sakte ne terren, eshte realizuar nje rrjet Stacionesh Topografike. Eshte perdorur metoda e mini trekendshave, duke matur stacionet e GPS me metoden "Faststatic". Secila pike eshte matur me GPS nga 20-30 min, duke marre ne konsiderate numrin e sateliteve ne kohen e matjes. Pas matjes me GPS, te dhenat jane procesuar me "Trimble Business Center".

Eshte perdorur "TRIMBLE R6 MODEL 3 GPS" me frekuence te dyfishte nga "TRIMBLE" per Rilevimet, dhe "Trimble Business Center" per perpunimin e te dhenave. Keto instrumente perfaqesojne disa nga teknologjite me te mira ne treg. Specifikimet e tyre teknike per rilevimet statike jane:



Trimble R6 model 3



Topcon GPT900A



Nivela Dixhitale Leica DNA 03



Trimble R6

Rilevimi statik GNSS

Precizion i larte statik

Horizontal. 3 mm + 0.1 ppm RMS

Vertikal. 3.5 mm + 0.4 ppm RMS

Statik and FastStatic

Horizontal. 3 mm + 0.5 ppm RMS

Vertikal. 5 mm + 0.5 ppm RMS

Rilevim Kinematik

Horizontal. 10 mm + 1 ppm RMS

Vertikal. 20 mm + 1 ppm RMS.

Mbas punes ne terren eshte bere perpunimi i te dhenave dhe lidhja e elementeve te te gjithes zones se Projektit, duke krijuar keshtu nje vizatim unik. Vizatimi eshte realizuar ne 3D, per te krijuar modelin dixhital te terrenit. Ne te jane te perfshira te gjitha detajet e relievit si: rruge, ura, tombino, perrenj, mure rrethues, shtepi, rrethime (gardh), linja elektrike, etj. Te gjitha stacionet jane paraqitur me shenja konvencionale lehtesisht te identifikueshme ne vizatim.

The digital model of the soil is represented as follow

- Pikat tre - dimensionale (x, y, z), me nje layer te vetem te quajtur "Topo – Geodetic Points"
- Linjat e jo te vazhdueshme te terrenit tre - dimensionale (x, y, z) (vijat e sipërme dhe te poshtme te prerjeve, mbushjeve mureve etj.), ne layer-a te ndryshem.
- Harta dixhitale perfundimtare eshte krijuar ne shkallen 1:1000 per te gjithes gjatesine e rruges.

Te gjithes elementet topografik jane te regjistruara ne memorje dixhitale. Elemente te tilla si Shtepi, Gardhe, Peme, Rruge, Tombino tubolare dhe box, Linja telefonike, Linja shperndarje, Kanale, Perrenj, Lumenj, Kushtet e tokes, Kabuj, Tubo, Shtylla, etj.

3.3 Prodhimi I hartes dixhitale

Te gjitha detajet topografike jane regjistruar me kode specifike ne memorjen e brendshme te instrumentave te perdorura nga Konsulenti.

Keto perfshijne por nuk jane te limituara ne shtresat rrugore, bankinat, mbushjet e skarpatave, prerjet e bimesise, urat, kryqezimet, strukturat e drenazhit, drenimet anesore, vijat ujore, punimet e mbrojtjes se skarpatave, kanalet e ujitjes, veprat e ujitjes, punimet e mbrojtjeve nga permbytja, muret mbajtese, barrierat akustike dhe te sigurise, pemet, ndertesat, hekurudhat, infrastruktura ekzistuese (p.sh. linjat elektrike, telefonike), nyjet etj.

Pikat e regjistruara ne terren jane transferruar ne programe kompjuterike respektive te projektit. Te gjitha pikat jane perpunuar me programin Sierrasoft Prost software.

Te gjitha pikat e marra ne terren jane importuar dhe perpunuar ne AutoCAD per te gjeneruar nje Model 3D te terrenit. Ne vizatime jane prezantuar me linja 3D te gjitha linjat e nderprera si : rruget, tombinot ekzistuese drejtkendore dhe rrethore, urat, lumenjte, perrenjte, muret mbajtese, ndertesat, gardhet, infrastruktura ekzistuese, etj. te identifikuara me vete. Te gjitha pikat e referimit jane paraqitur me shenja konvencionale ne vizatime.

Modeli Dixhital i Terrenit eshte paraqitur ne skedaret DWG si me poshte :

- Tre – dimensional pikat (x,y,z), ne nje "layer" te vetem
- Tre – dimensional linjat e shkeputura (x,y,z) (fillimet e prerjeve, te mbushjeve, koka dhe kembat e murit etj.) ne "layer" te ndryshem.

4 LIST OF BENCHMARKS' (BM) COORDINATES

Nr.	X	Y	Z	Stacionet Topografike	Menyra e Fiksimit
1	4580144.6	391658.8	105.6	B1 a	HEKUR+BETON
2	4580371.0	378696.9	52.5	B1 b	GOZHDE NE BETON
3	4580357.8	378699.1	52.6	B2	GOZHDE NE BETON
4	4577989.7	396599.6	106	B4	HEKUR+BETON
5	4580437.9	378688.6	52.4	B4 b	HEKUR+BETON
6	4580276.8	378700.6	53.2	B6	HEKUR+BETON
7	4578576.5	375598.2	53.4	B6 b	GOZHDE NE BETON
8	4579160.8	394263.7	91.7	B10	HEKUR+BETON
9	4579156.9	394253.8	91.9	B11	GOZHDE NE ASFALT
10	4579165.9	394162.6	91.5	B12 a	HEKUR+BETON
11	4579652.4	393183.3	87.1	B12	HEKUR+BETON
12	4579888.5	392438.7	82.8	B21	GOZHDE NE ASFALT
13	4581467.3	389226.6	101.8	B35	HEKUR+BETON
14	4581652.9	389124.6	102.9	B36	HEKUR+BETON
15	4580153.1	391761.5	92.5	ST2	GOZHDE NE BETON
16	4579769.7	392709.4	84.2	ST19	
17	4577796.4	397151.4	111.1	B100	VIDE NE TROTUAR
18	4578092.5	396531.6	105.4	B101	GOZHDE NE TROTUAR ASFALT
19	4578113.7	396487.9	104.9	B102A	GOZHDE NE TROTUAR ASFALT
20	4578378.3	395792.2	99.7	B127	GOZHDE NE TROTUAR ASFALT
21	4578524.9	395628.2	98.5	B103	GOZHDE NE TROTUAR ASFALT
22	4578871.1	394902.5	95.6	B104	GOZHDE NE TROTUAR ASFALT
23	4579035.6	394406.9	93.5	B126	GOZHDE NE BETON
24	4579396.0	393805.4	92.9	B105	GOZHDE NE TROTUAR

25	4579576.4	393427.9	90.7	B107	GOZHDE NE TROTUAR
26	4579601.6	393376.9	90.2	B106	GOZHDE NE TROTUAR
27	4579917.2	392485.5	82.8	B108	GOZHDE NE TROTUAR
28	4580015.5	392072.7	82.9	B125	GOZHDE NE TROTUAR
29	4580396.1	391601.7	96.3	B109	GOZHDE NE TROTUAR
30	4580558.8	390561.9	90.3	B110	VIDE NE BORDURE
31	4580617.4	390531.9	90	B111	VIDE NE BORDURE
32	4580591.4	390364.9	89.9	B10050	VIDE NE TROTUARE
33	4581080.5	389458.4	94.9	B112	GOZHDE NE TROTUAR
34	4581844.1	388959.5	103.5	B124	GOZHDE NE TROTUAR
35	4581950.8	388949.3	104.1	B113	GOZHDE NE TROTUAR
36	4582641.5	388372.8	99.7	B114	GOZHDE NE TROTUAR
37	4583517.5	387603.6	92.4	B116	GOZHDE NE TROTUAR
38	4583535.1	387583.5	92.2	B115	GOZHDE NE BETON
39	4583988.4	386403.3	86.6	B117	GOZHDE NE BETON
40	4583301.0	385700.5	76.6	B118	GOZHDE NE TROTUAR
41	4582435.8	385162.9	70.8	B119	GOZHDE NE TROTUAR
42	4582408.5	385173	70.7	B123	GOZHDE NE BETON
43	4581607.7	384650.8	68.1	B120	GOZHDE NE TROTUAR
44	4581116.9	384060.2	65.9	B121	GOZHDE NE TROTUAR
45	4580854.5	383161.1	63.2	B122	VIDE NE TROTUARE
46	4580164.6	378557.4	53.3	B158	VIDE NE BETON
47	4579833.6	377976.8	57.8	B157	GOZHDE NE MUR BETONI
48	4579712.4	377693.9	53.7	B128	GOZHDE NE MUR BETONI
49	4579584.5	377418.3	60.4	B129	GOZHDE NE MUR BETONI
50	4579525.1	377364.8	59.4	BM80/2	
51	4579202.6	376734.8	47.9	B130	GOZHDE NE BORDURE
52	4579082.8	376547.2	48.1	B156	GOZHDE NE

					BANKINE
53	4578886.5	376128.3	47.7	B131	GOZHDE NE BANKINE
54	4578680.8	375774.7	46.4	B155	GOZHDE NE BETON
55	4578642.1	375656.5	46.2	B132	GOZHDE NE BETON
56	4578617.3	375569.4	52.1	B133	GOZHDE NE BETON
57	4578395.8	375226.7	46.6	B154	GOZHDE NE TROTUAR
58	4578341.8	375065.3	45.8	B134	GOZHDE NE BORDURE BETONI
59	4578127.1	374662.2	45	B135	GOZHDE NE BETON
60	4578061.5	374578.7	45.4	B152	GOZHDE NE ASFALT
61	4577939.9	374260.8	50.6	B136	VIDE NE ASFALT
62	4577697.0	373878.1	43.2	B151	VIDE NE ASFALT
63	4577582.5	373625.6	37	B137	GOZHD NE TROTUAR
64	4577382.6	373301.5	42.8	B138	GOZHDE NE BANKINE
65	4577259.6	373203.4	35.6	B150	GOZHDE NE ASFALT
66	4576949.1	372808.6	36.4	B139	GOZHDE NE BETON
67	4576706.0	372617.8	36.9	B149	GOZHDE NE TROTUARE
68	4576729.3	372538.9	41.7	B140	GOZHDE NE TROTUARE
69	4576502.7	372405	35.8	B148	VIDE NE BETON
70	4576368.1	372248.8	36.2	B141	VIDE NE BETON
71	4576083.0	372097.8	36.1	B147	VIDE NE BETON
72	4575793.6	371988.4	36.6	B142	VIDE NE BORDURE
73	4575335.7	371983.2	36.6	B146	VIDE NE ASFALT
74	4575042.7	371954.5	44.9	B145	VIDE NE ASFALT
75	4574984.4	371831.3	36.1	B144	VIDE NE BORDURE
76	4575003.8	371737.2	36.4	B143	VIDE NE TROTUARE
77	4580775.5	381984.6	56.5	B160	VIDE NE BETON
78	4580705.4	381269.7	57.1	B161	GOZHDE NE ASFALT
79	4580664.3	380648.1	57.5	B162	GOZHDE NE ASFALT

80	4580649.5	379966.6	53.2	B163	VIDE NE BETON
81	4580624.5	379440.6	55.2	B164	VIDE NE BETON
82	4580449.1	379069.8	62	B165	VIDE NE BETON
83	4578598.2	375593.1	53.4	B201	GOZHDE BETON URE
84	4578594.2	375585.8	53.4	B202	GOZHDE BETON URE
85	4578341.6	375074.1	45.9	B203	GOZHDE BETON URE

Tabela 1 – Koordinatat e Stacioneve Topografike

5 MONOGRAFIA E STACIONEVE TOPOGRAFIKE



Figura 1- B 1 a



Figura 2- B 1 b

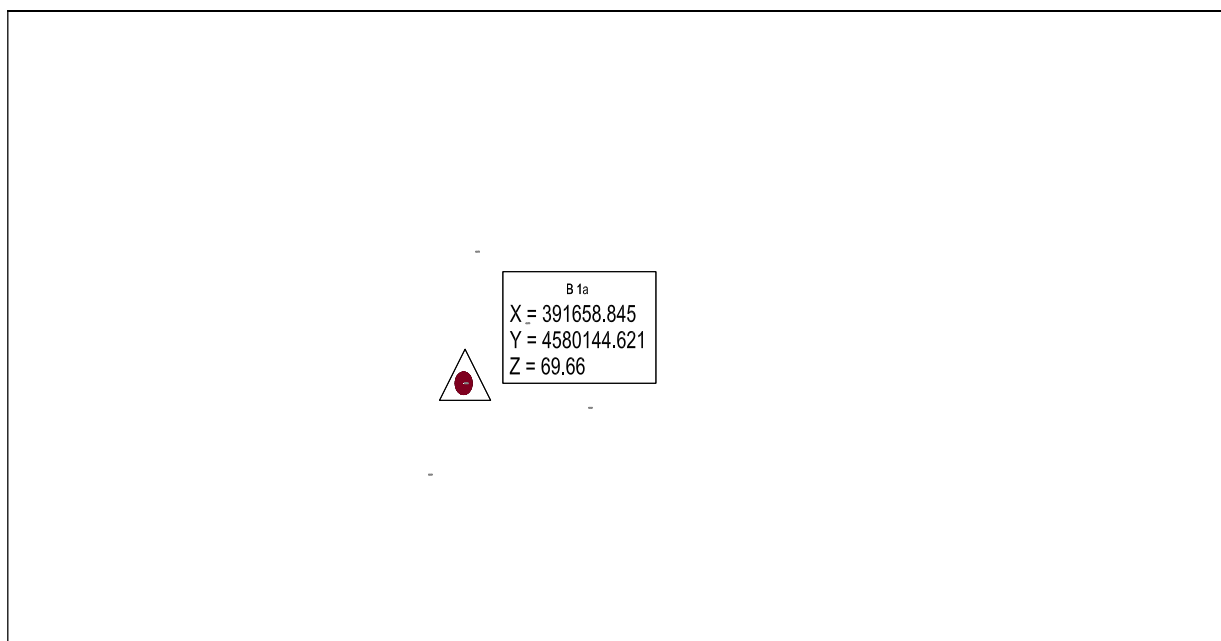

Figura 3- B 2

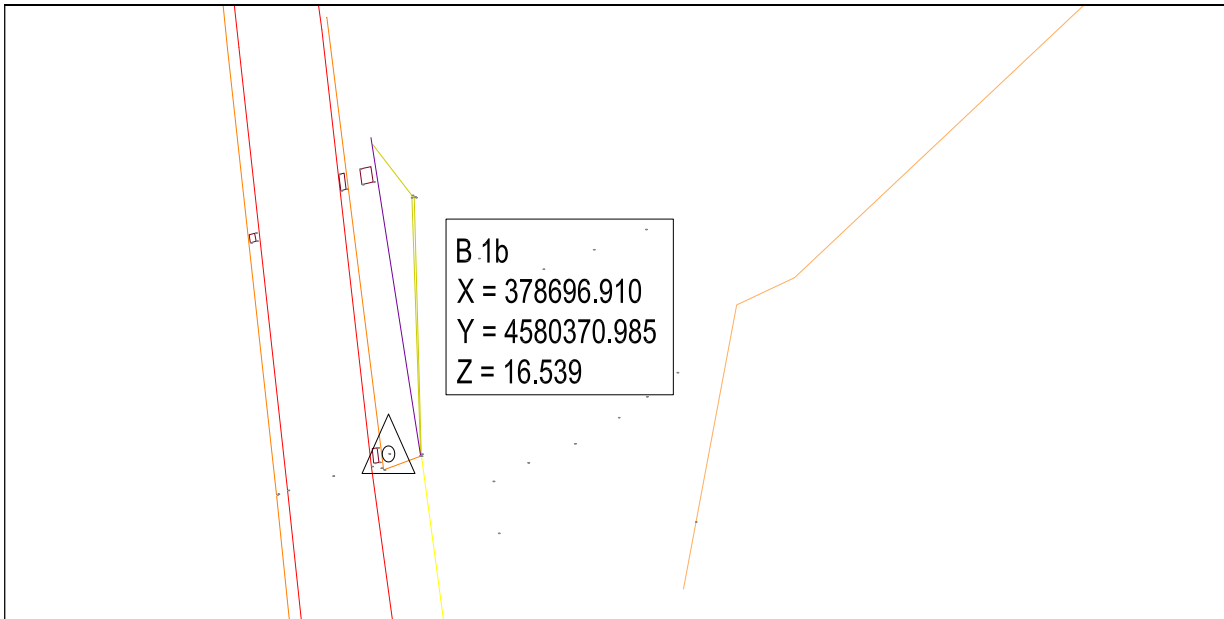

Figura 4- B 4a

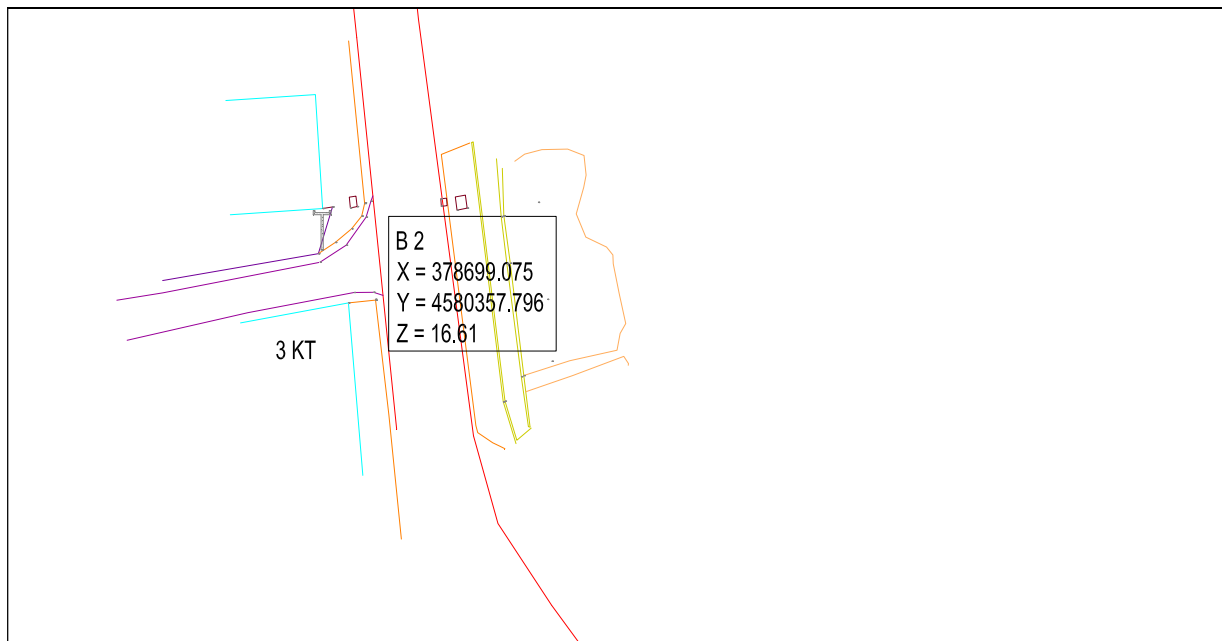

Figura 5 - B 4 b

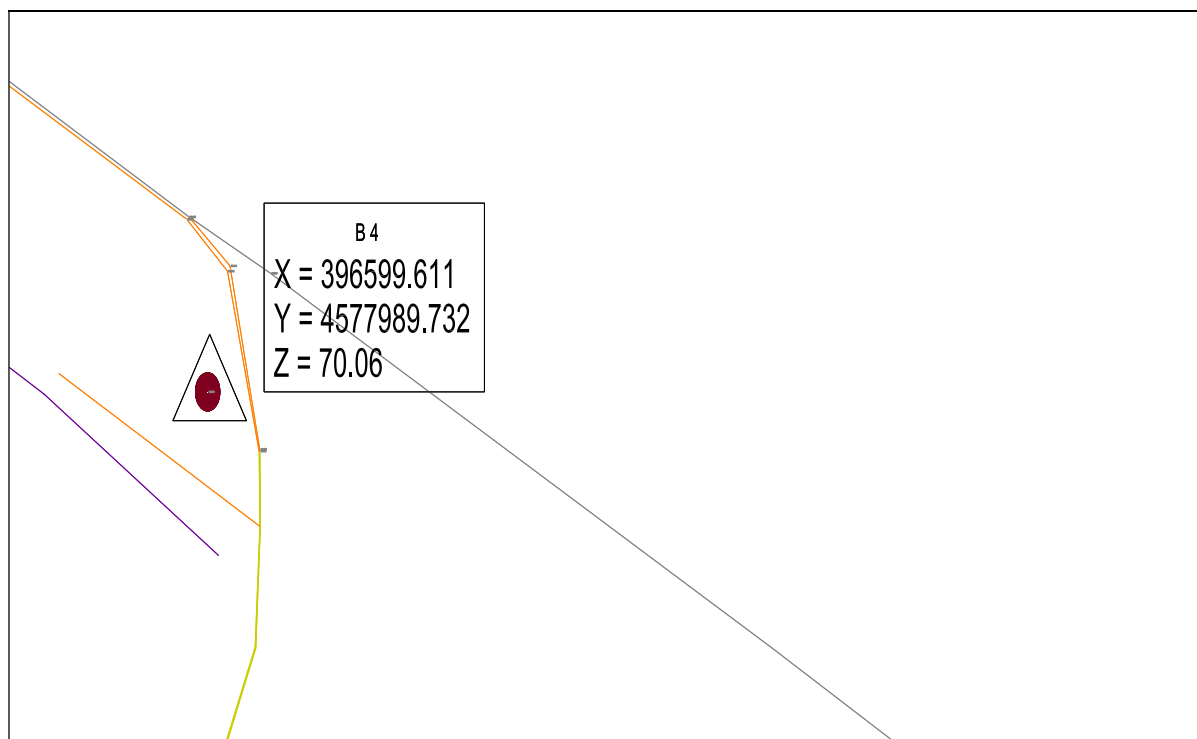

Figura 6 - B 6a

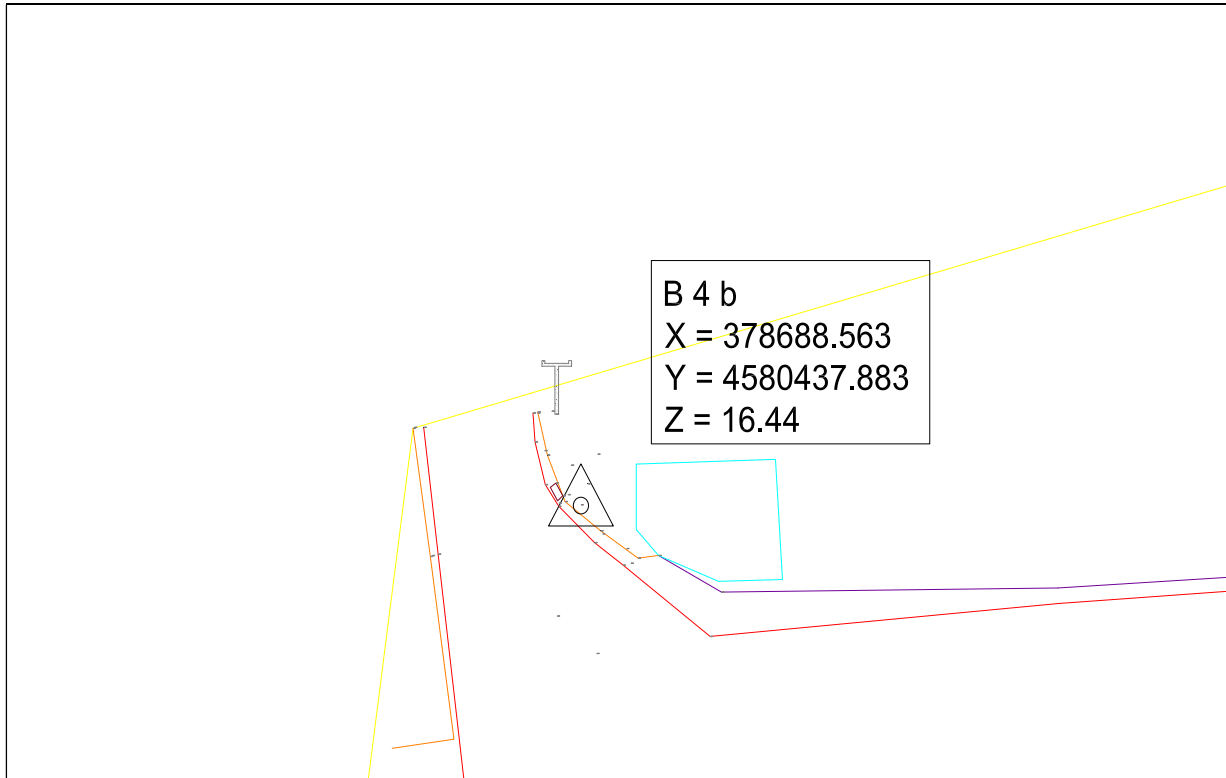

Figura 7- B 6 b

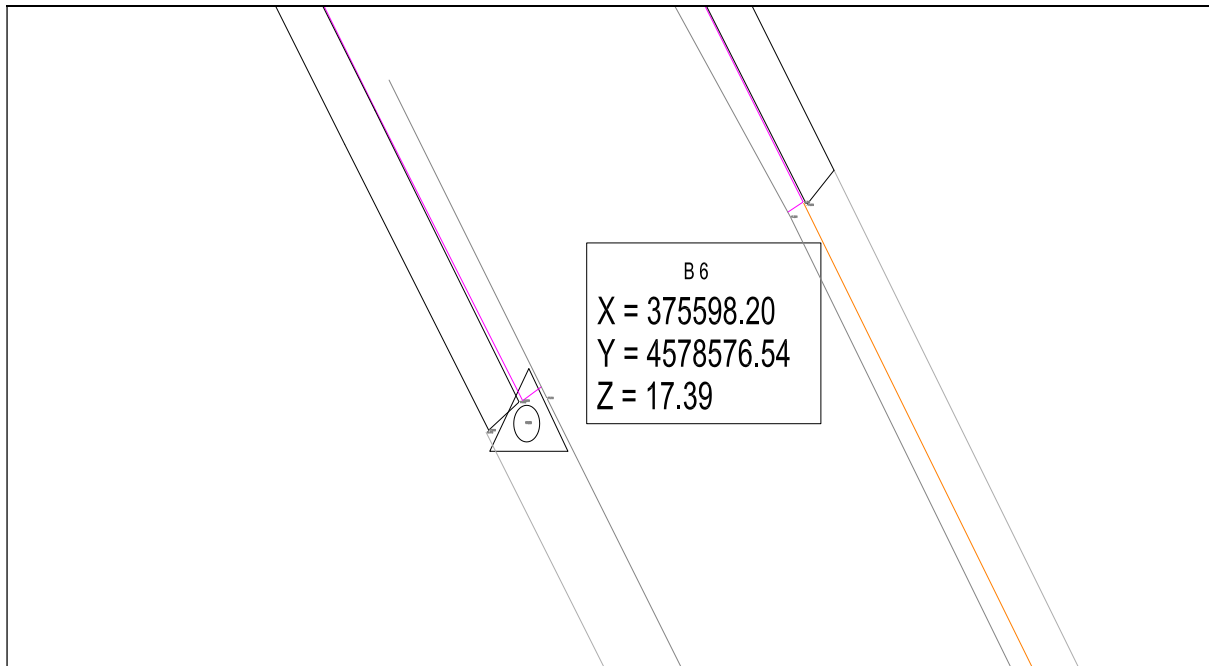

Figura 8 - B 10, B 11

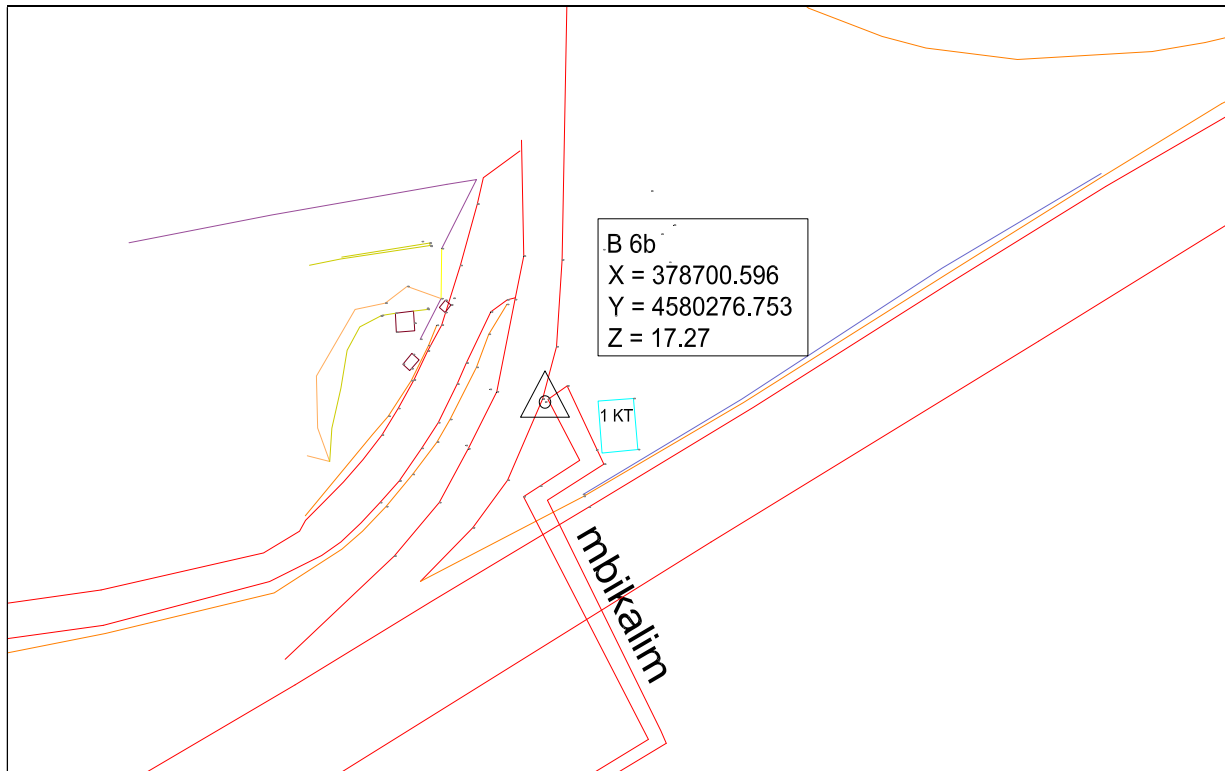

Figura 9 - B 12 a

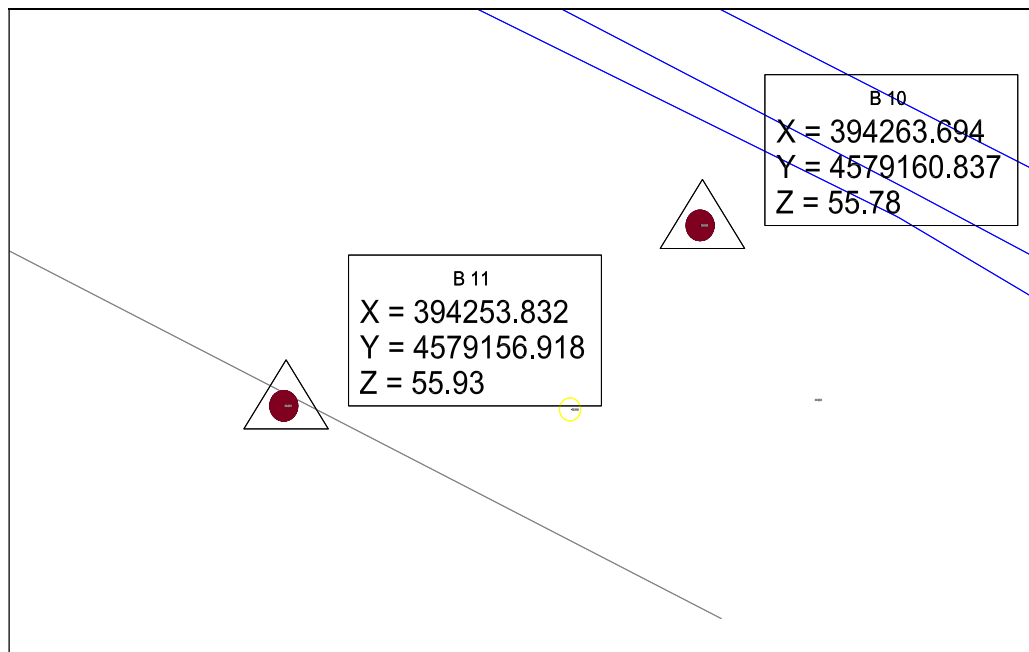

Figura 10 - B 12 b

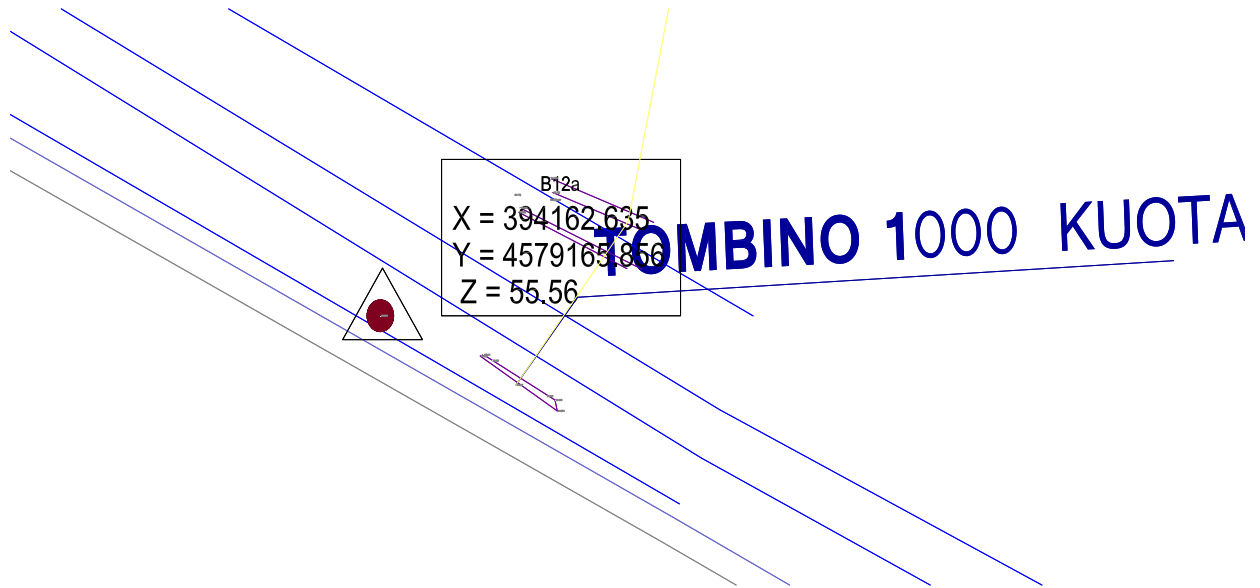

Figura 11- B 21

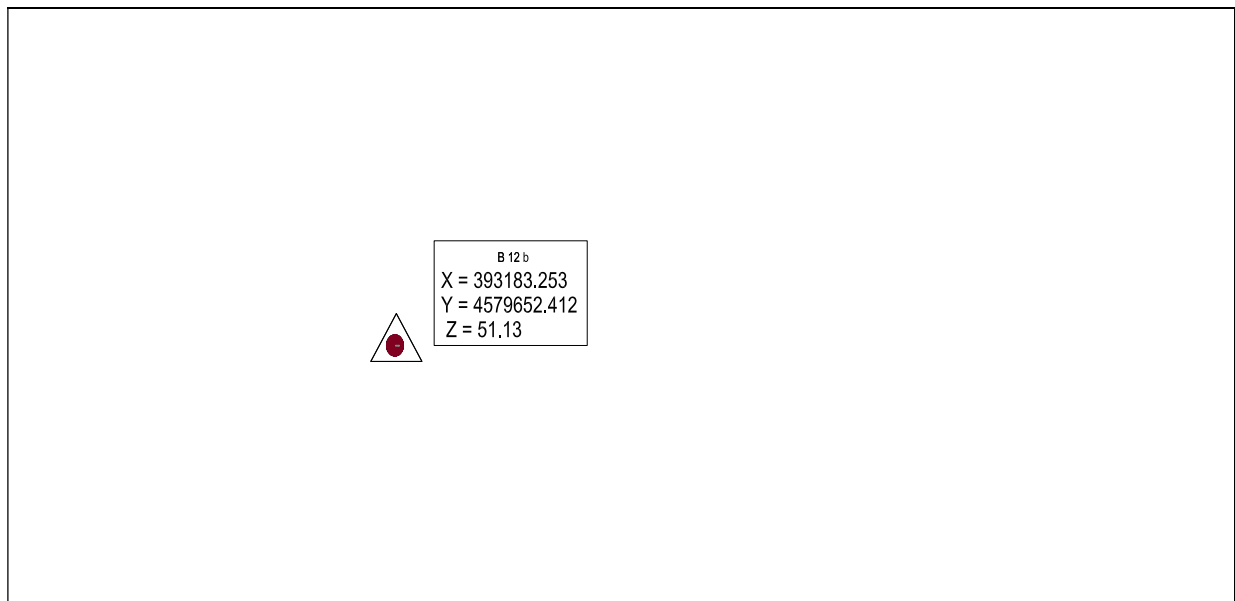

Figura 12- B 35

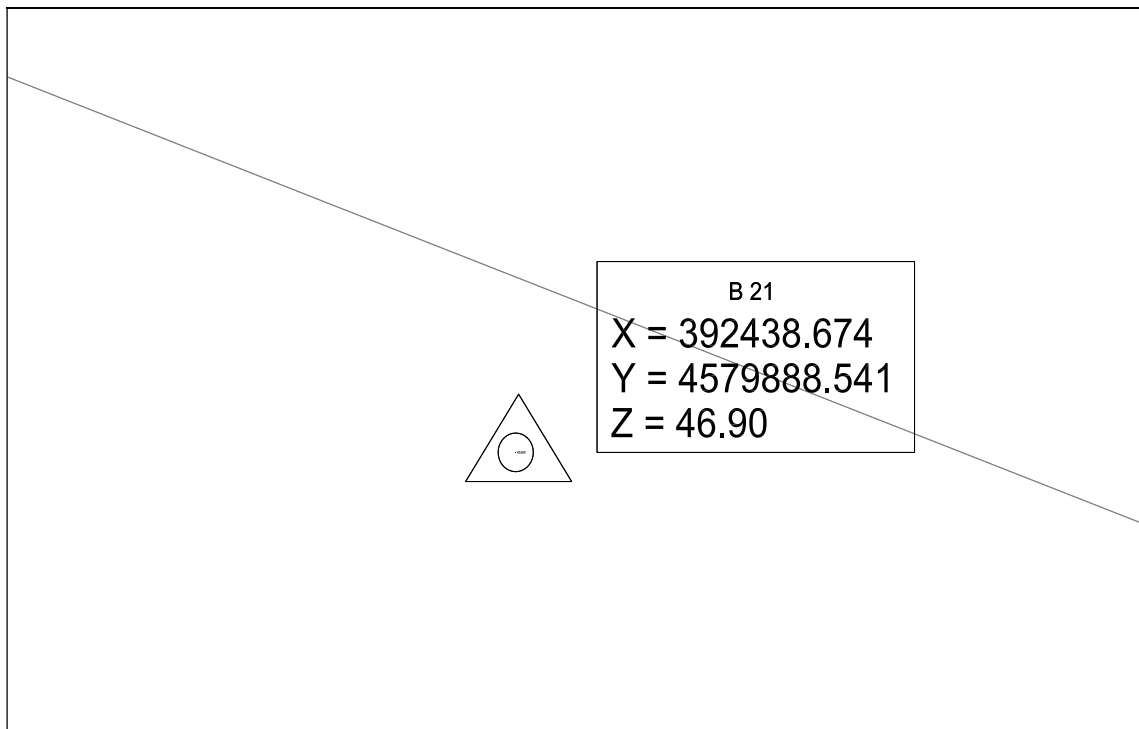

Figura 13- B 36

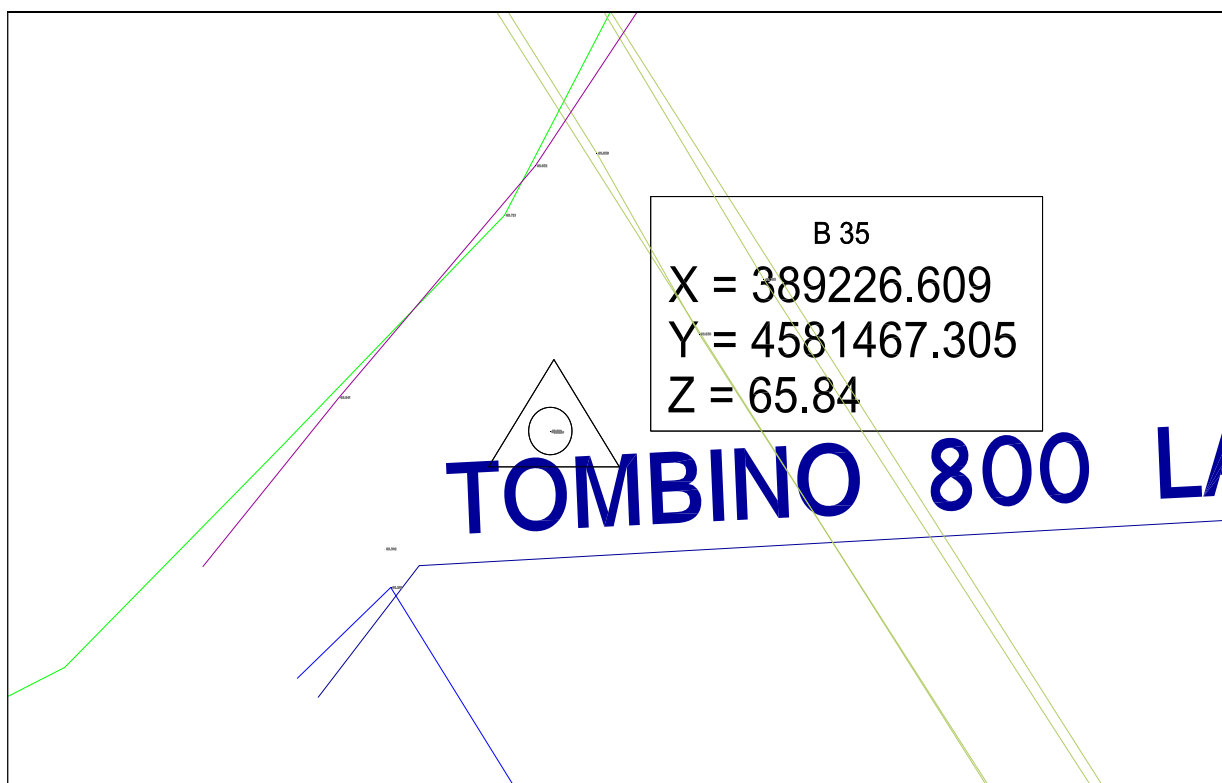

Figura 14- ST2

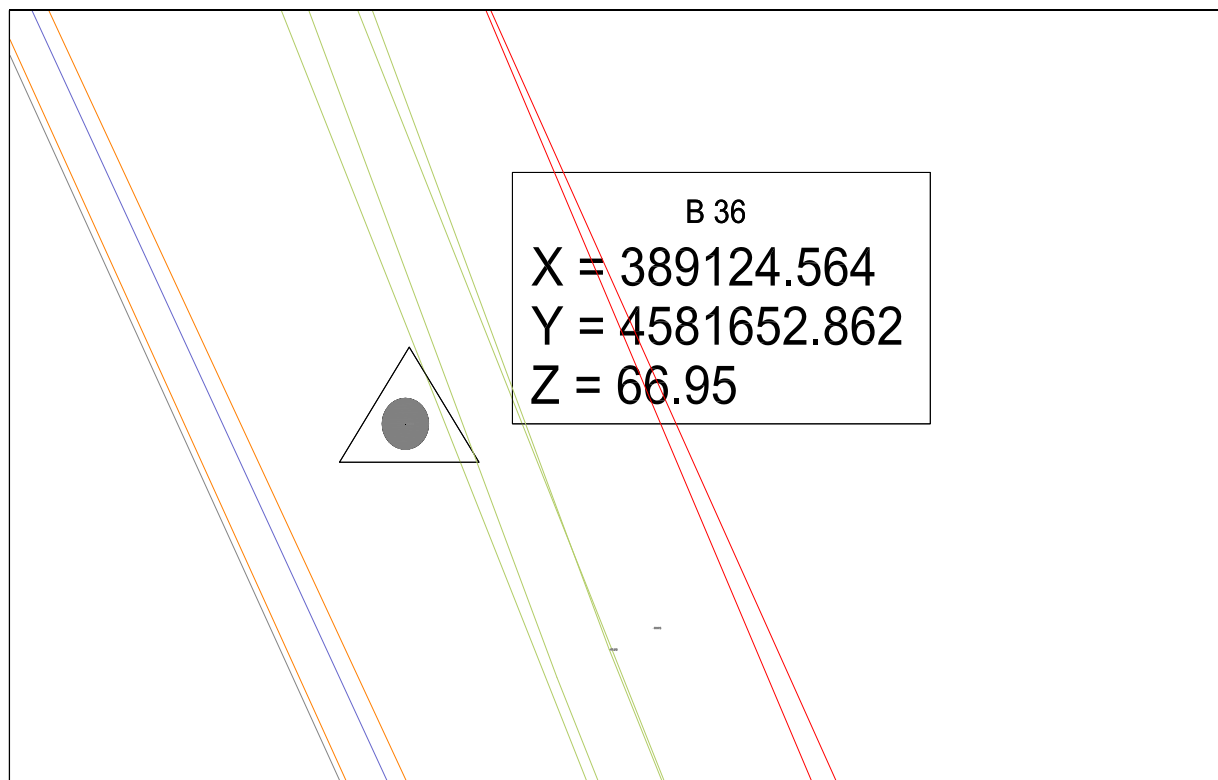

Figura 15- ST 19

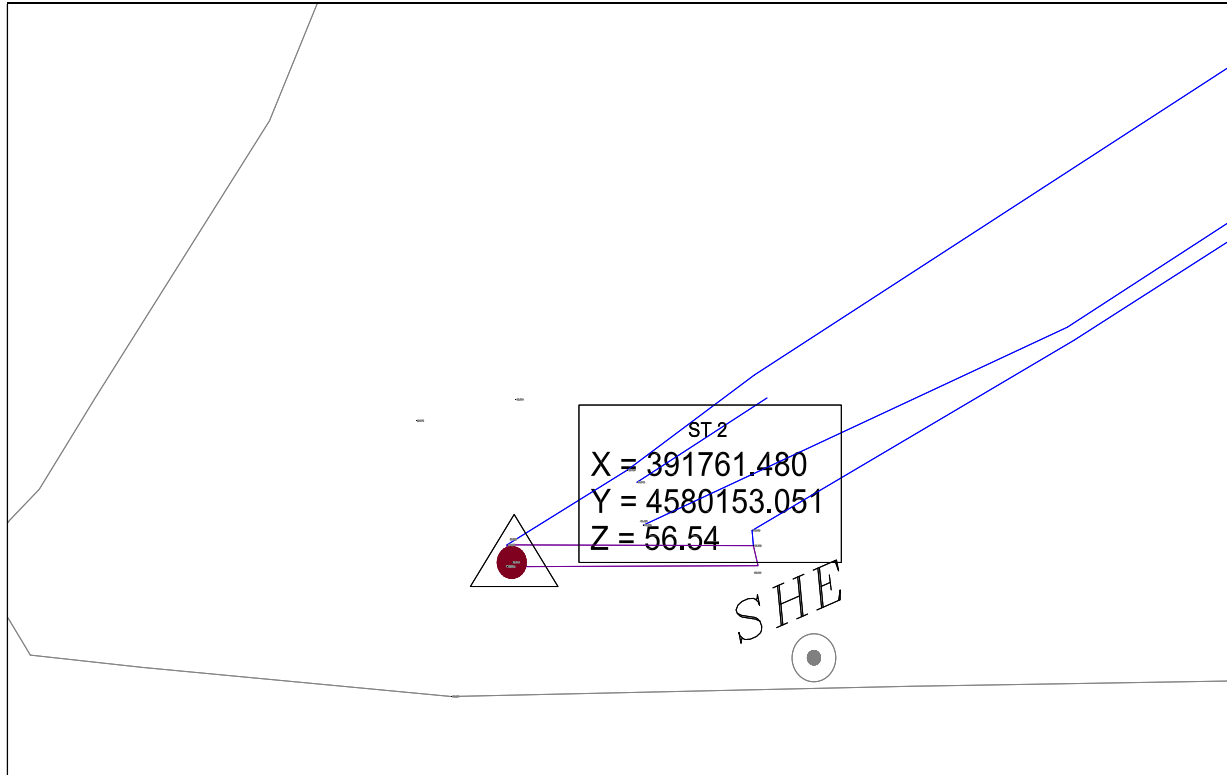

Figura 16- B 100

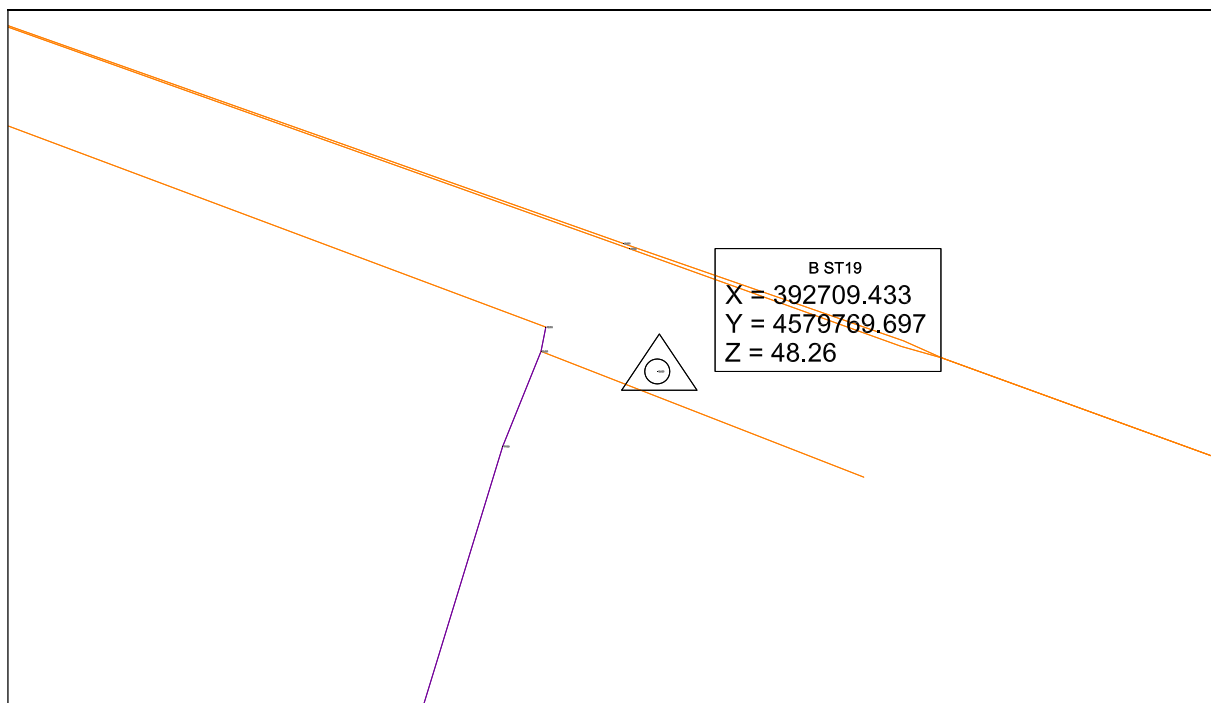

Figura 17- B 101

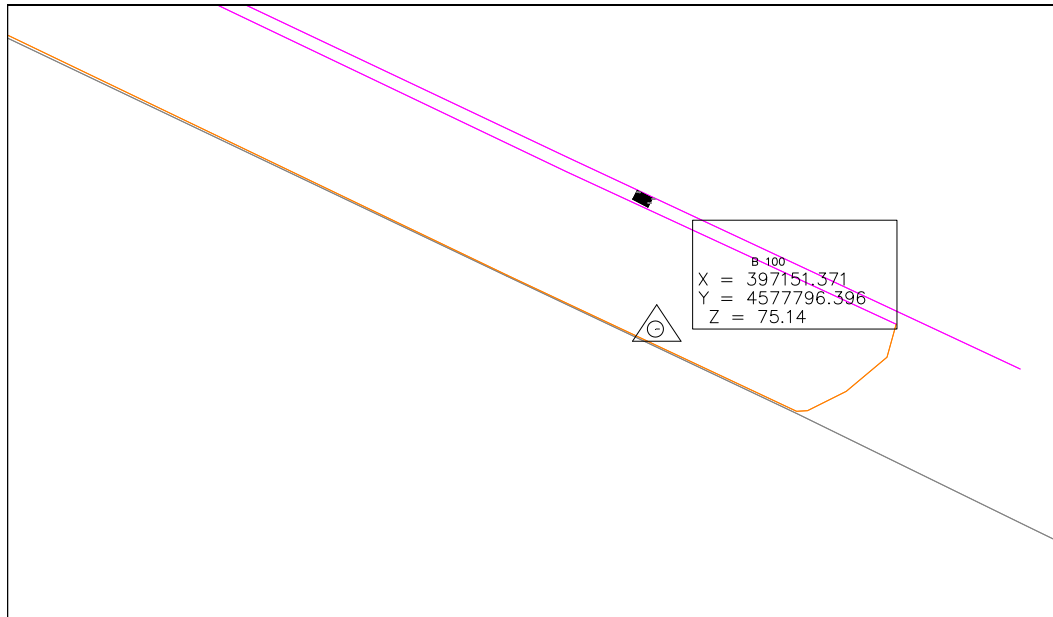

Figura 18- B 102 A

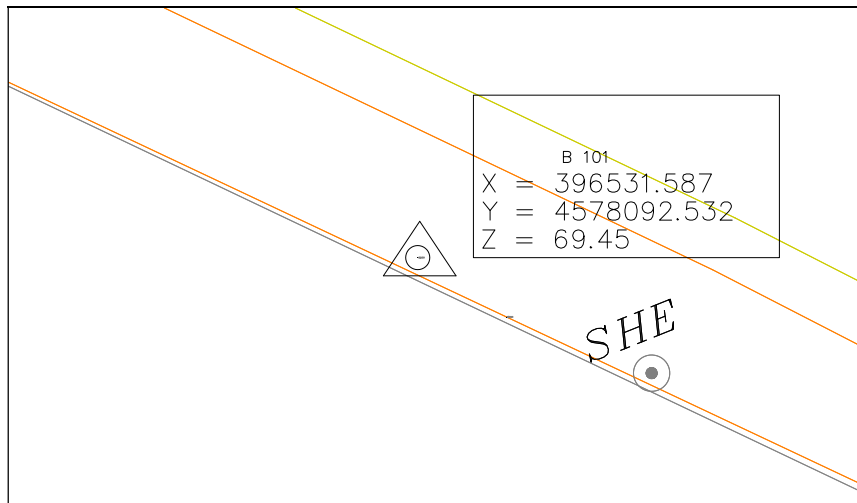

Figura 19- B 127

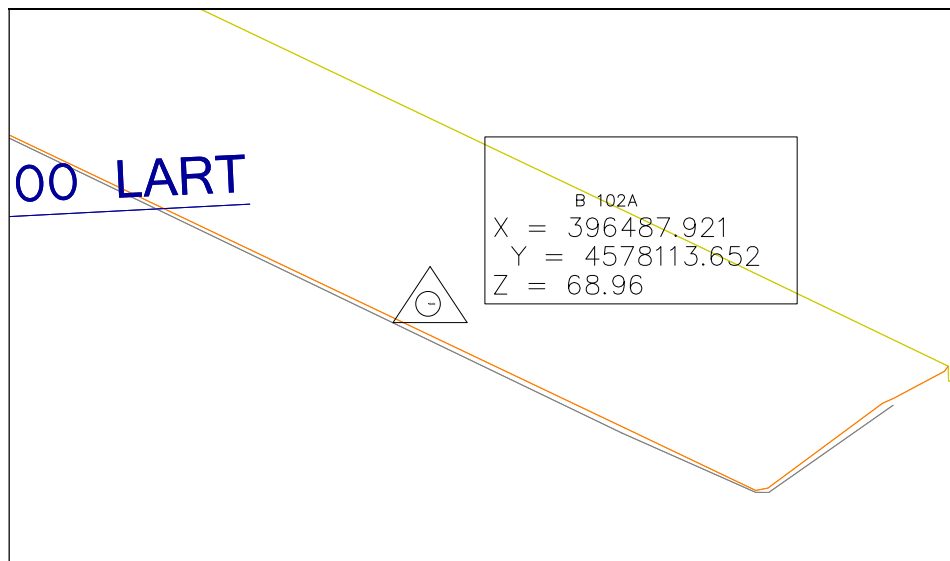

Figura 20- B 103

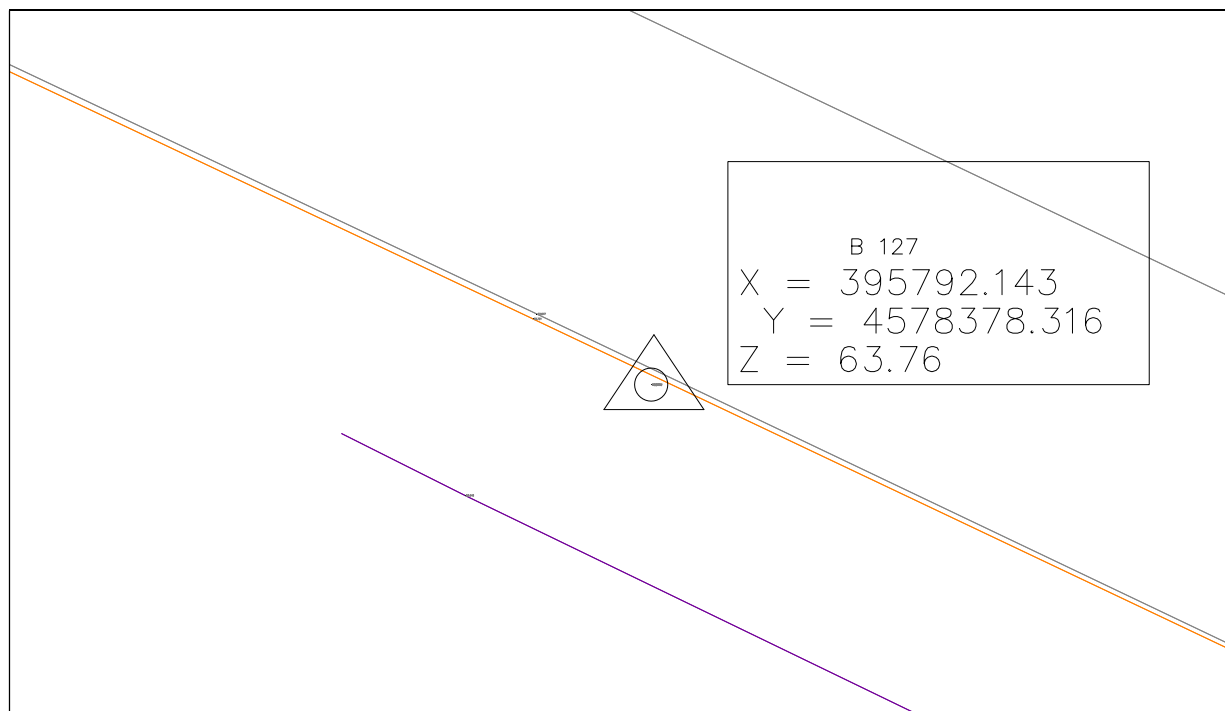

Figura 21- B 104

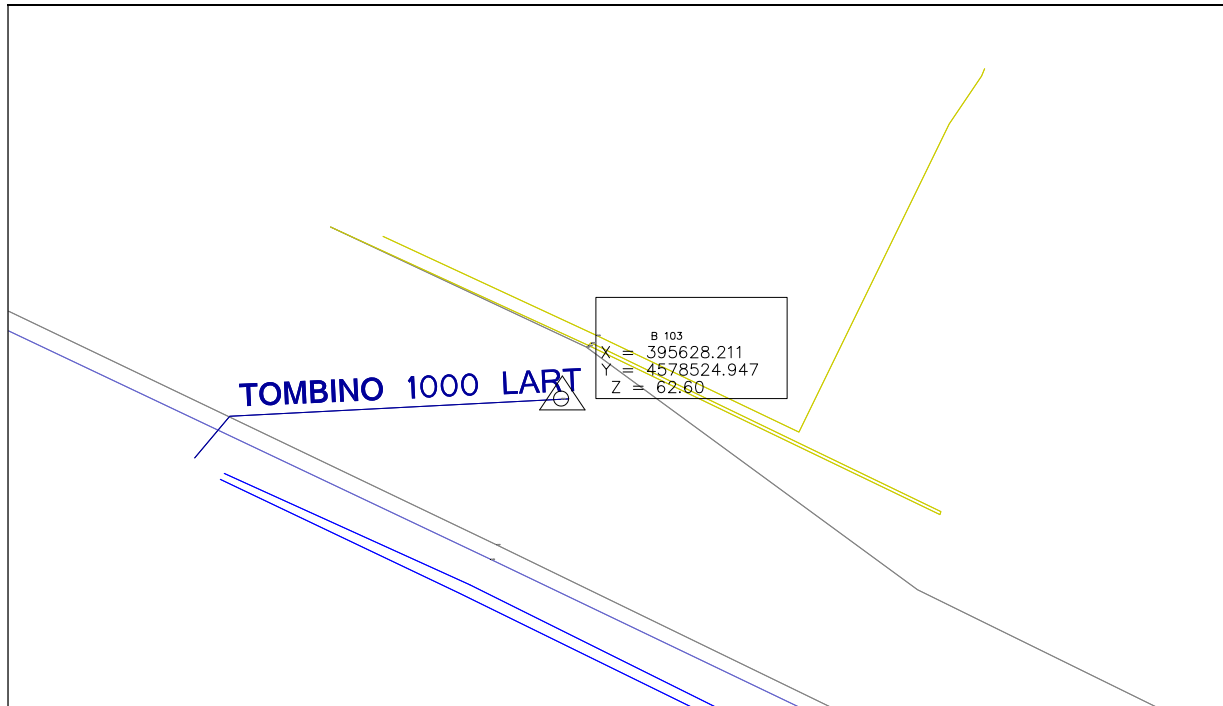

Figura 22- B 126

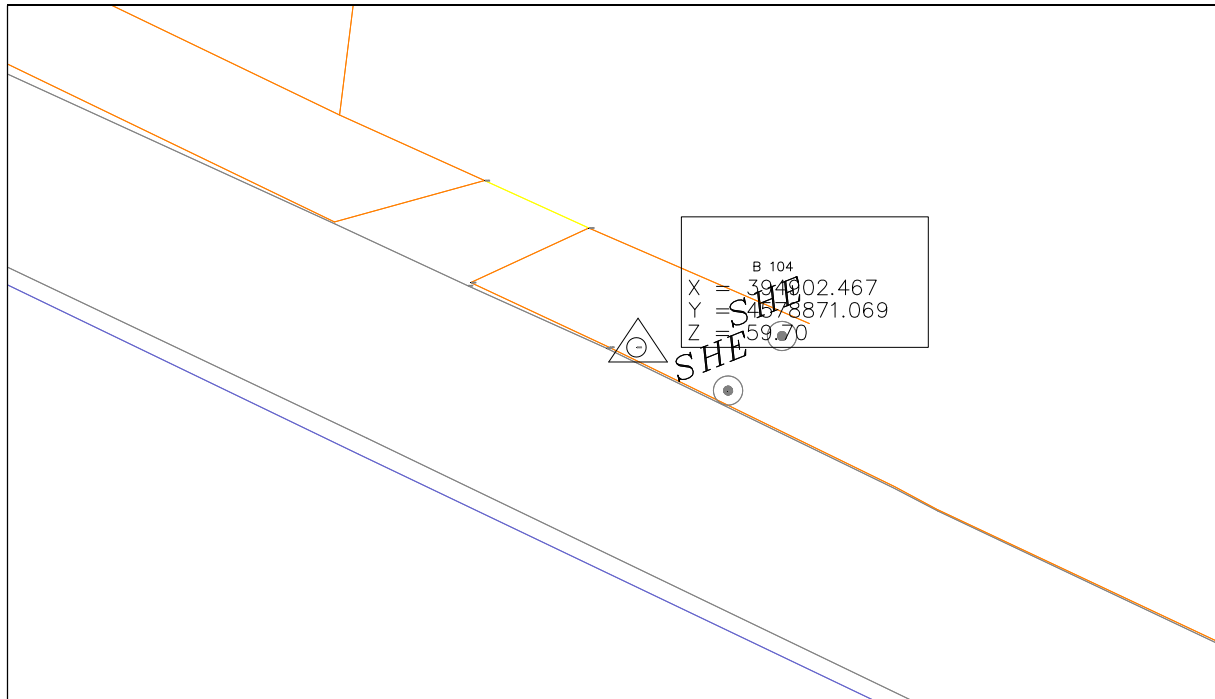

Figura 23- B 105

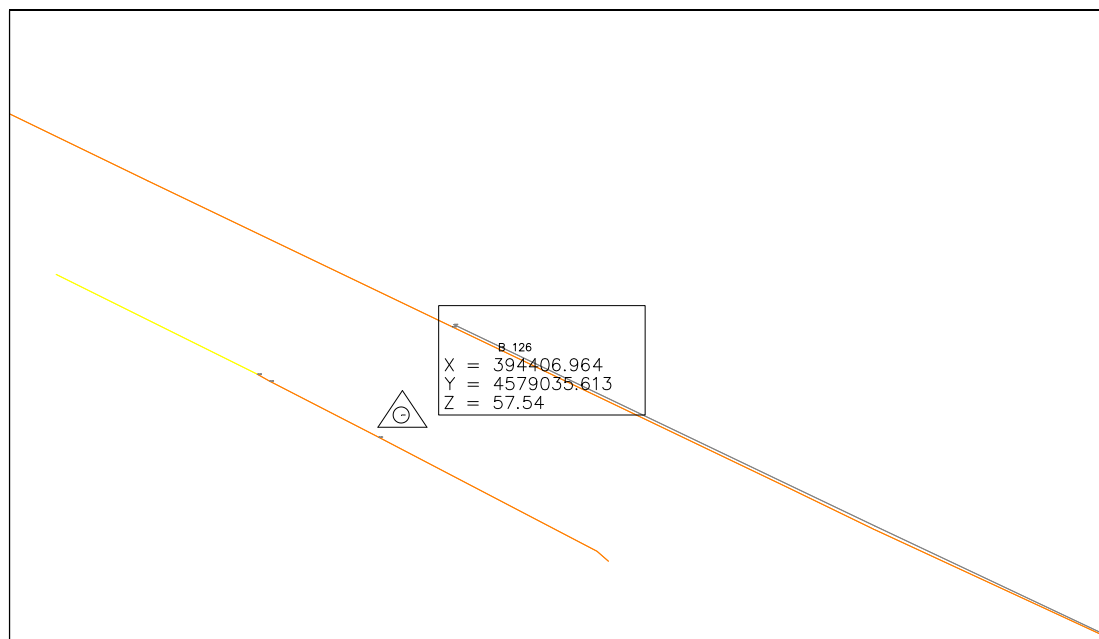

Figura 24- B 107

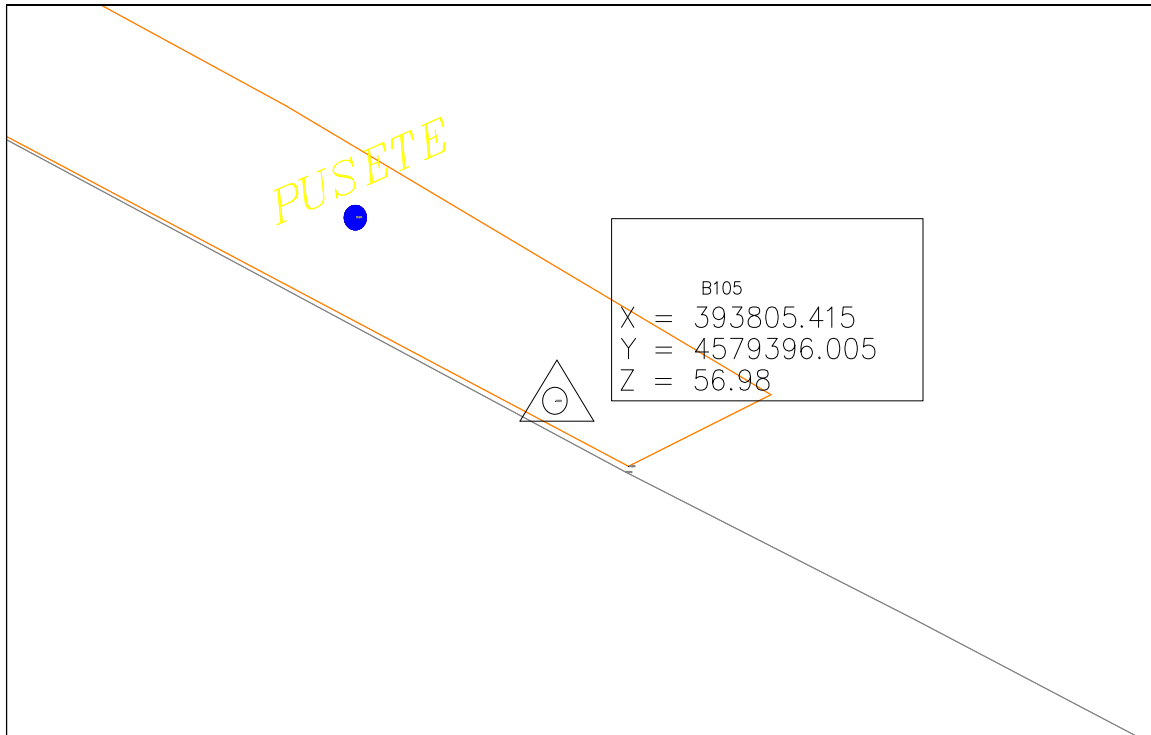

Figura 25- B 106

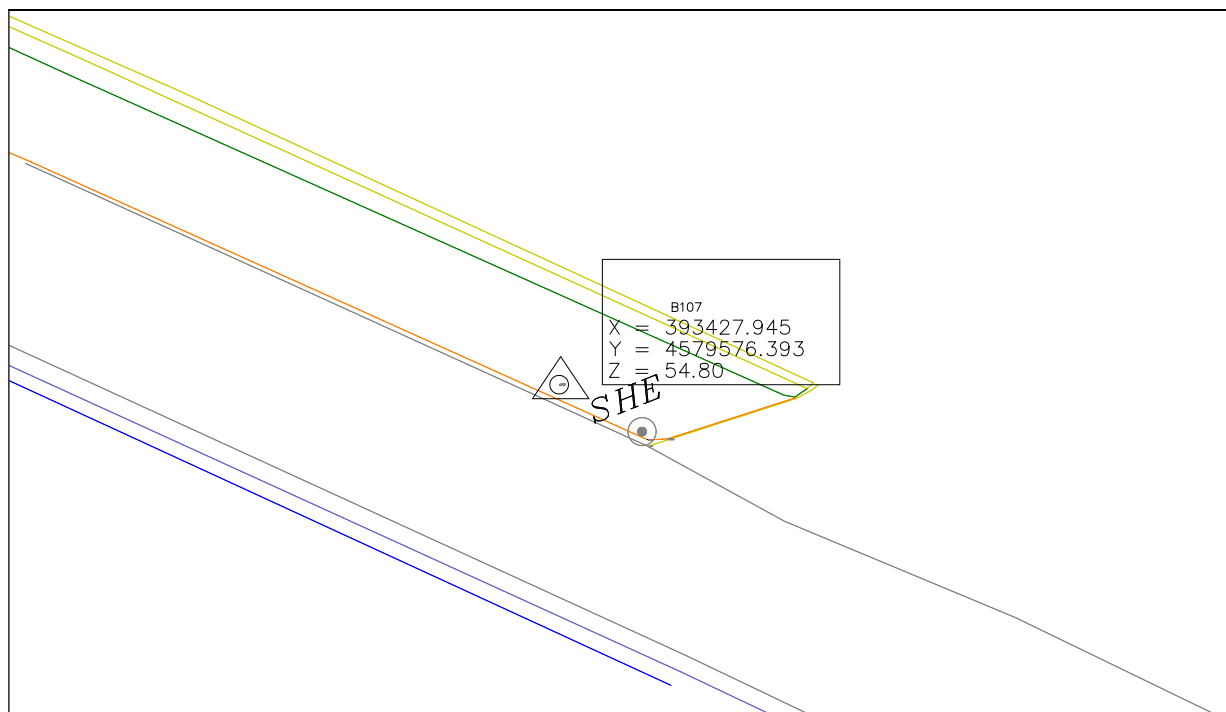

Figura 26- B 108

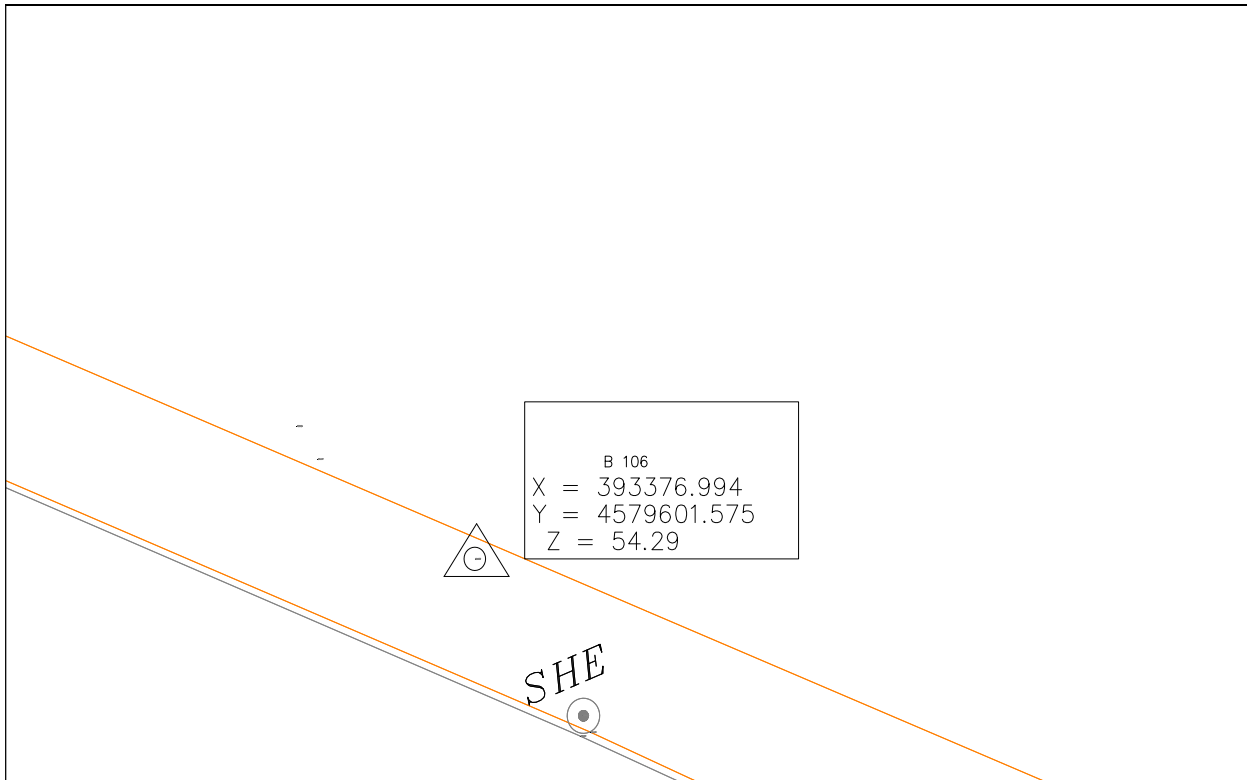

Figura 27- B 125

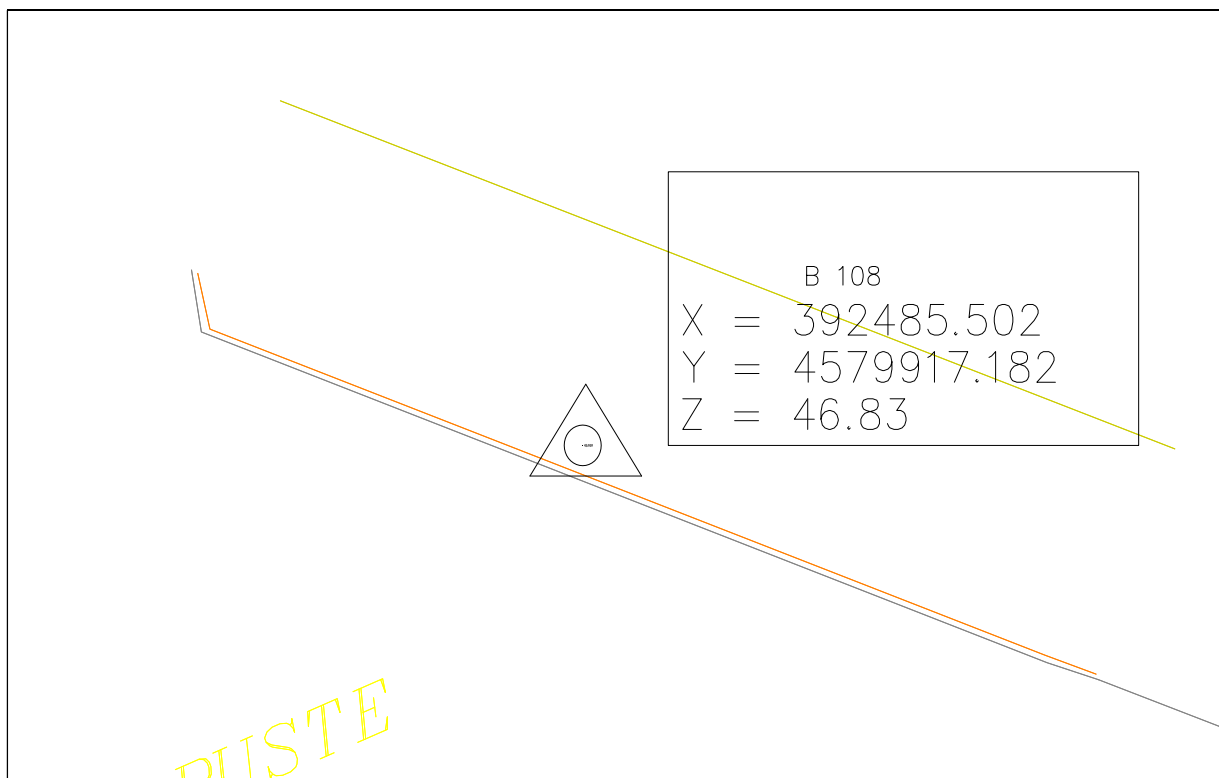

Figura 28- B 109

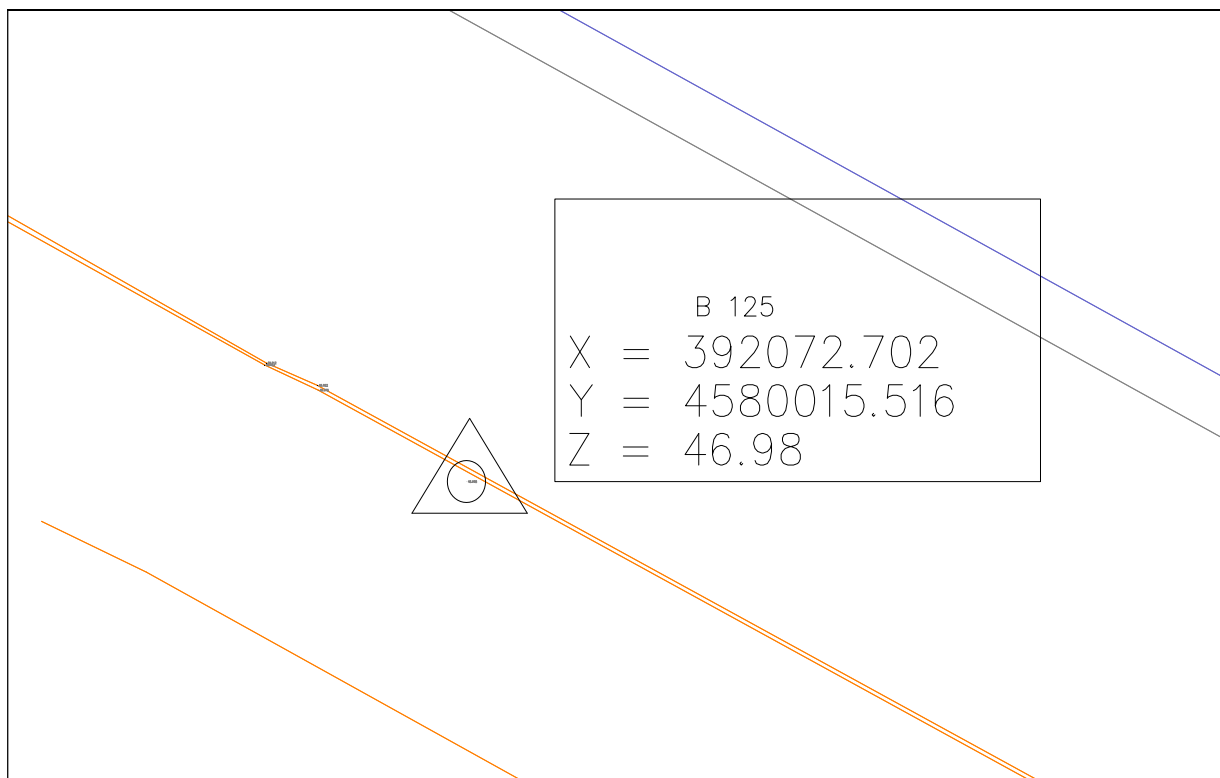

Figura 29- B 110

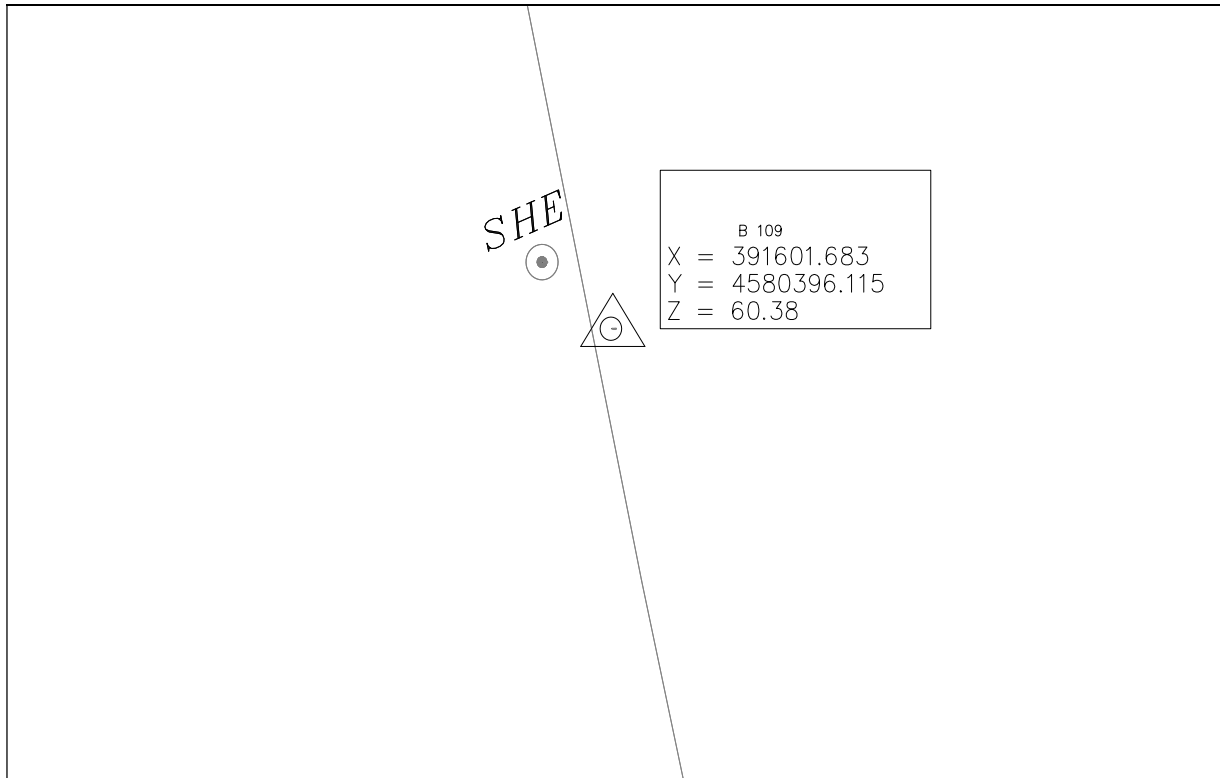

Figura 30- B 111

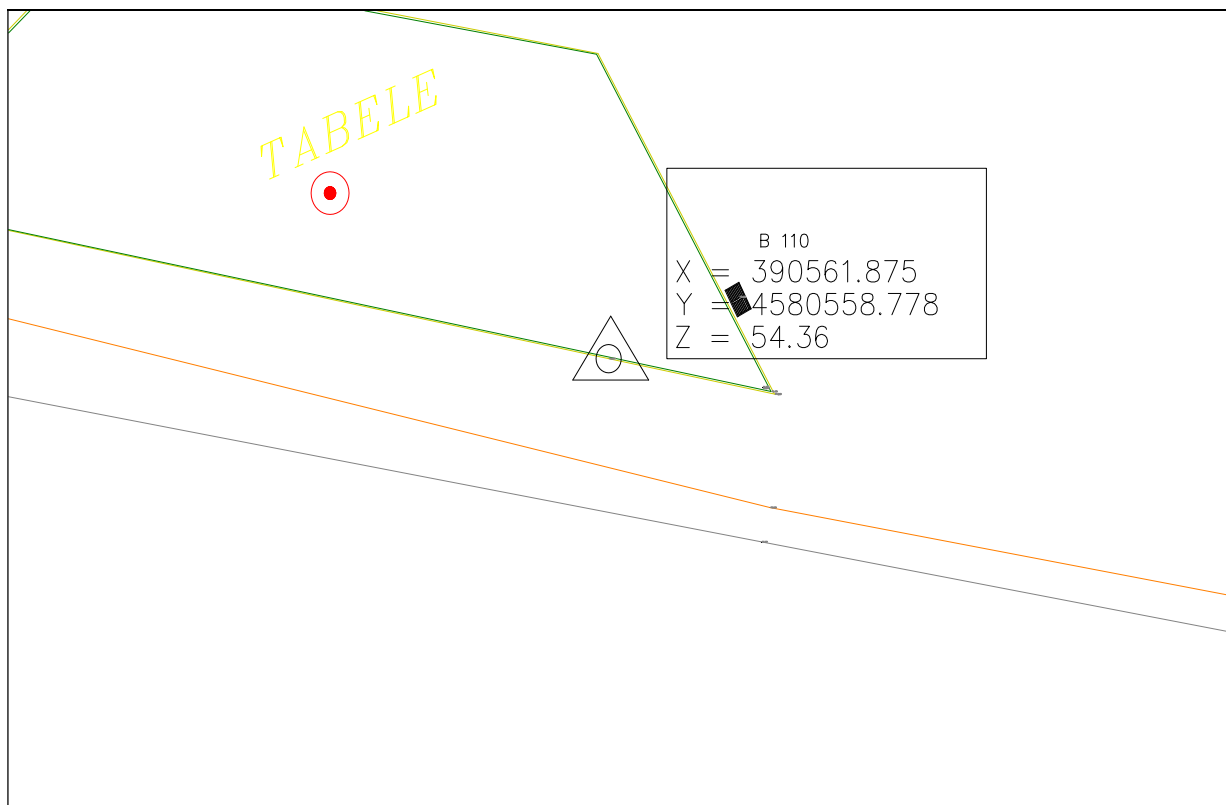

Figura 31- B 10050

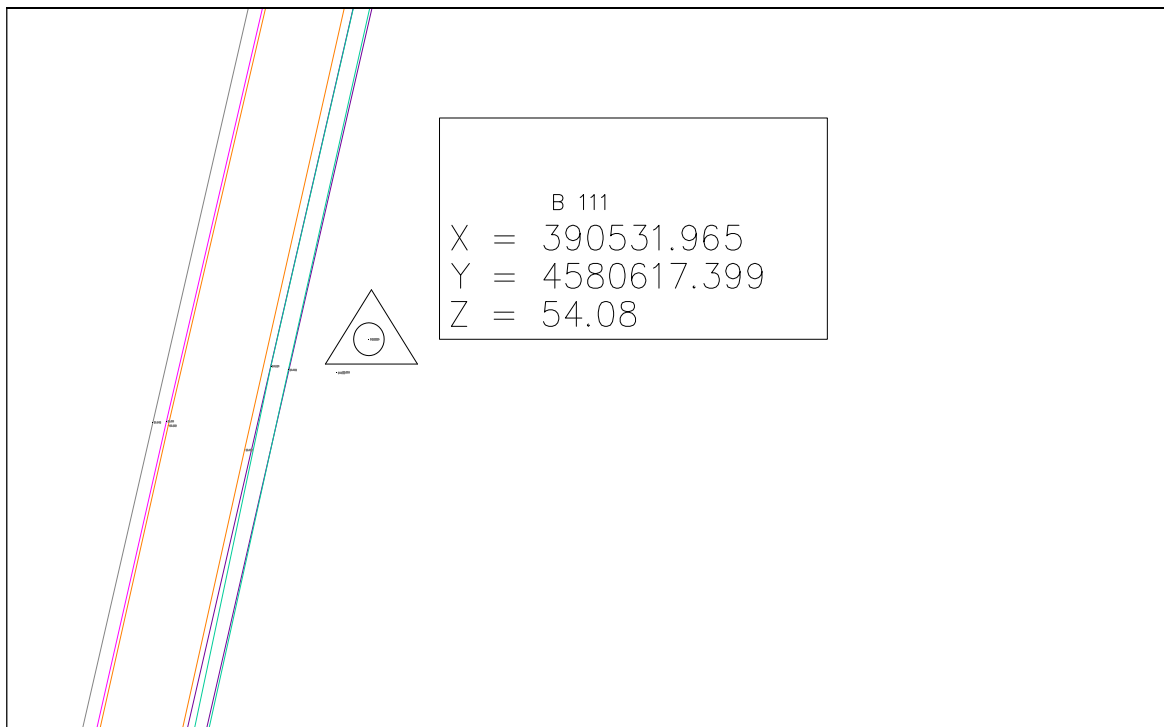

Figura 32- B 112

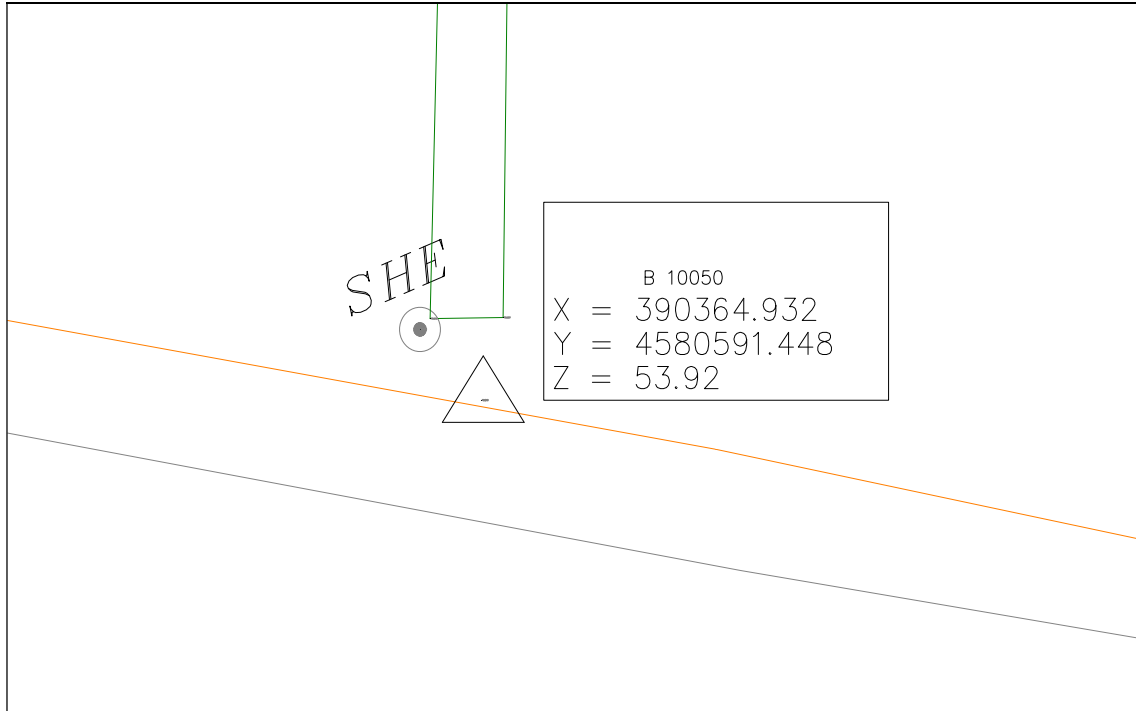

Figura 33- B 124

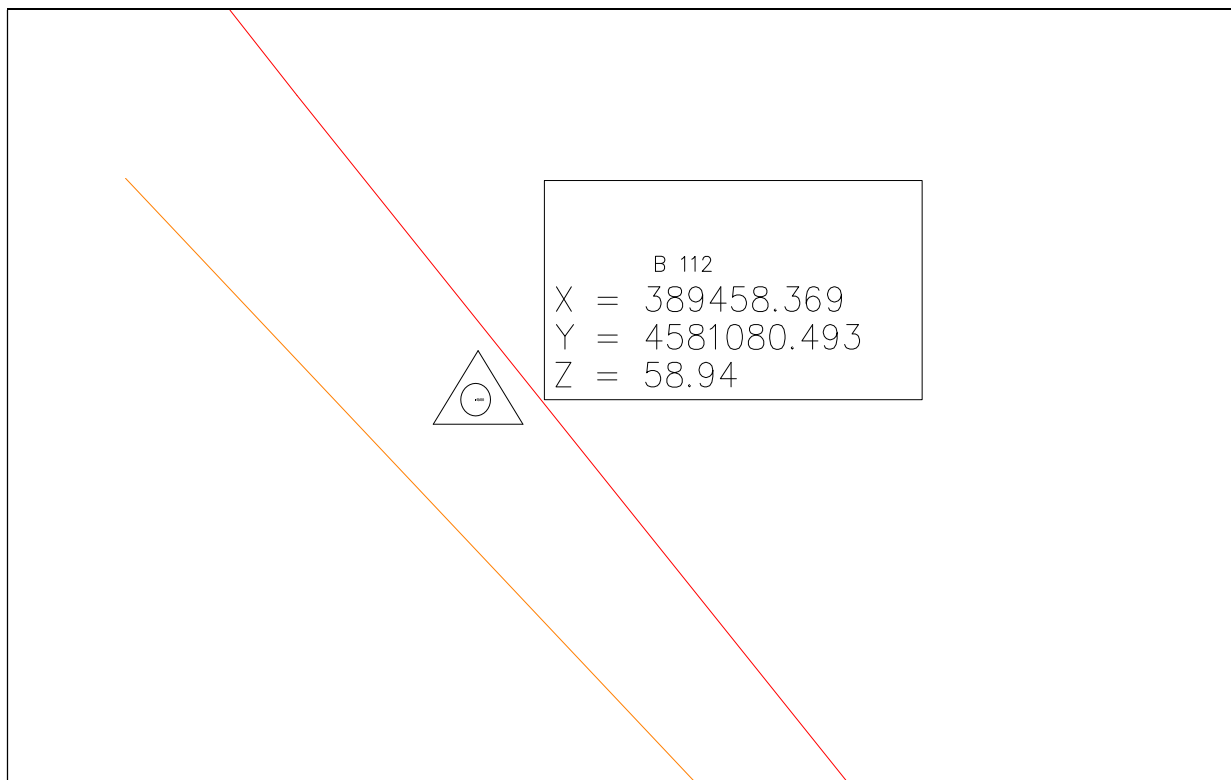

Figura 34- B 113

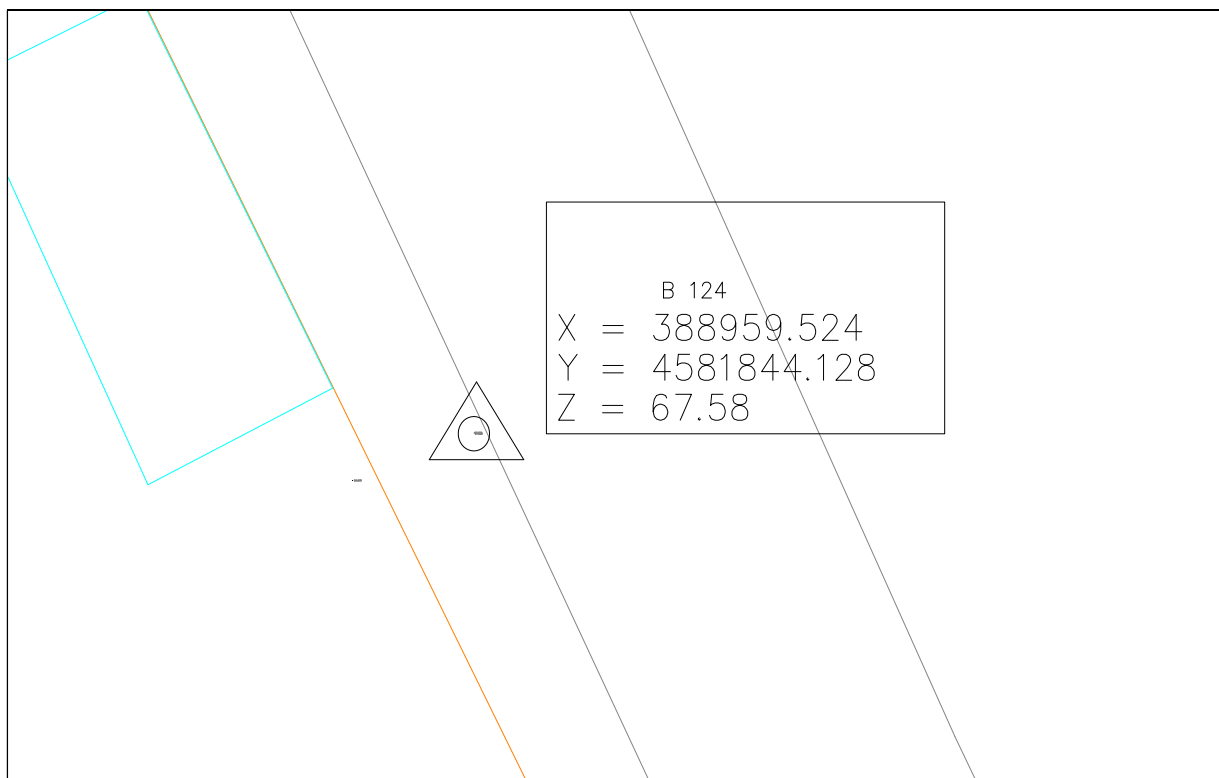

Figura 35- B 114

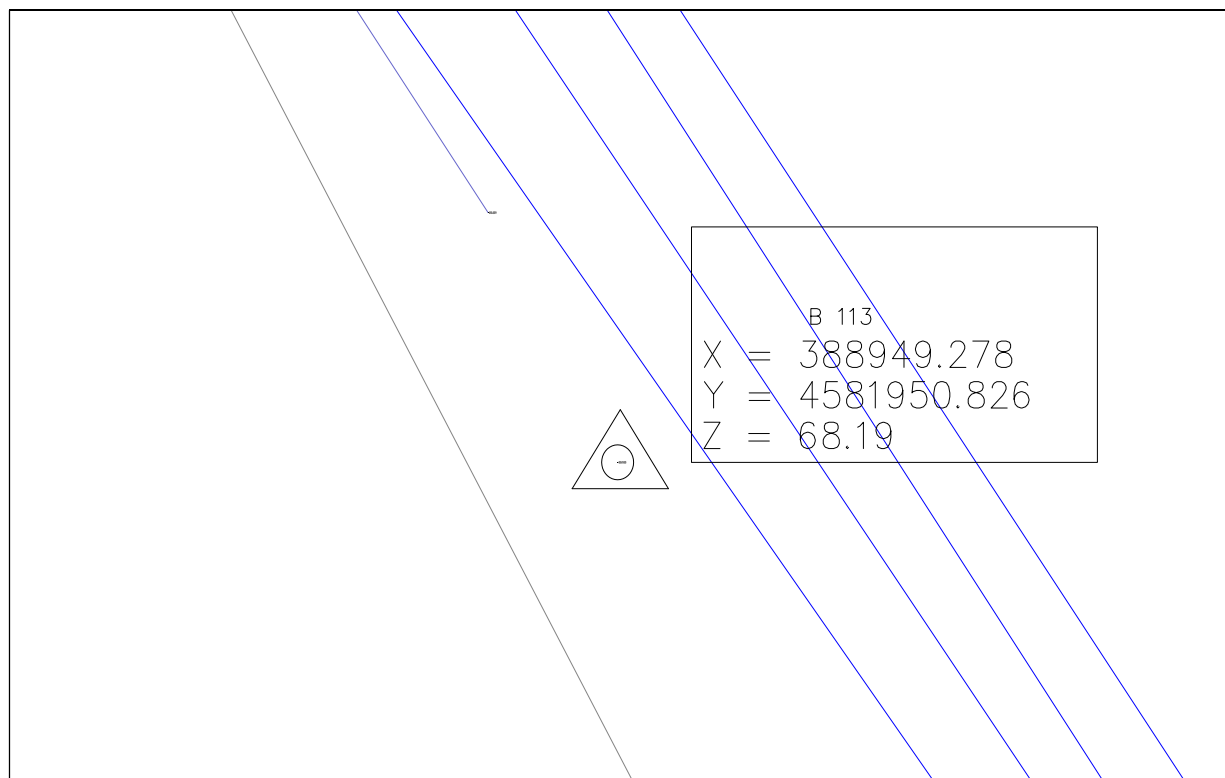

Figura 36- B 116

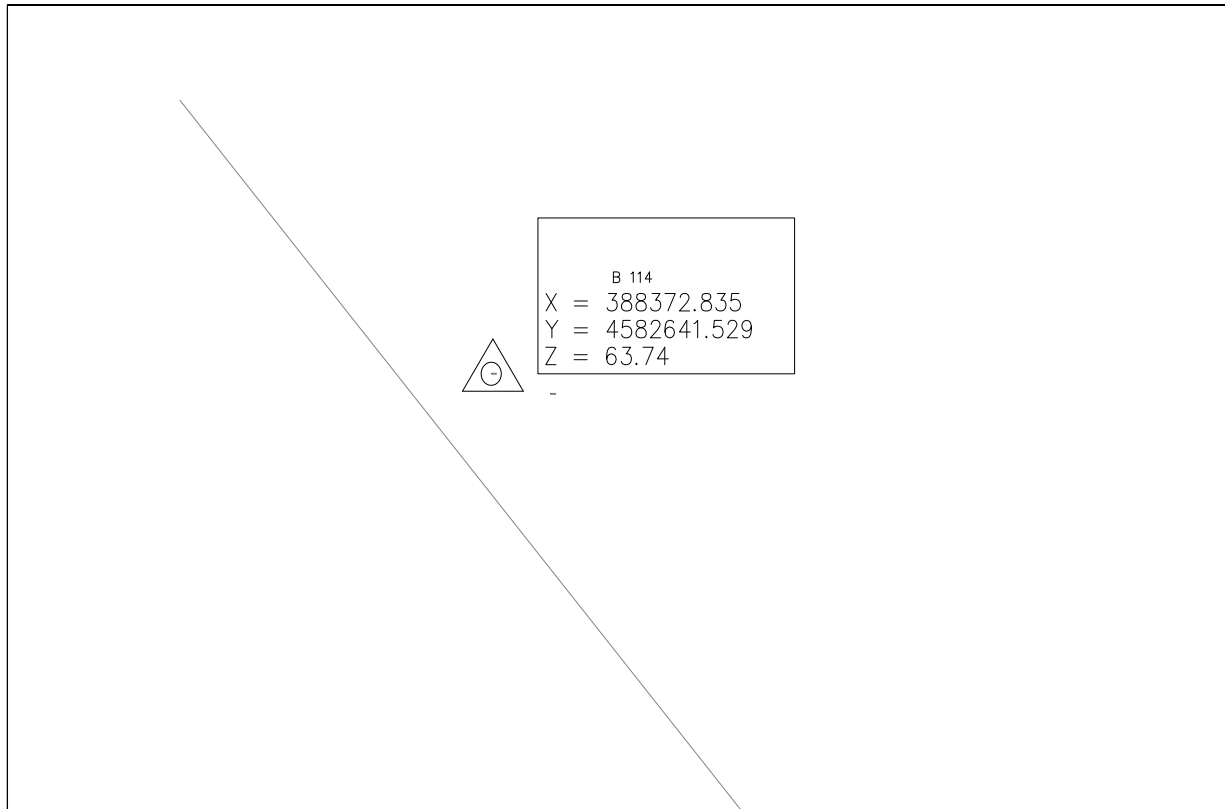

Figura 37- B 115

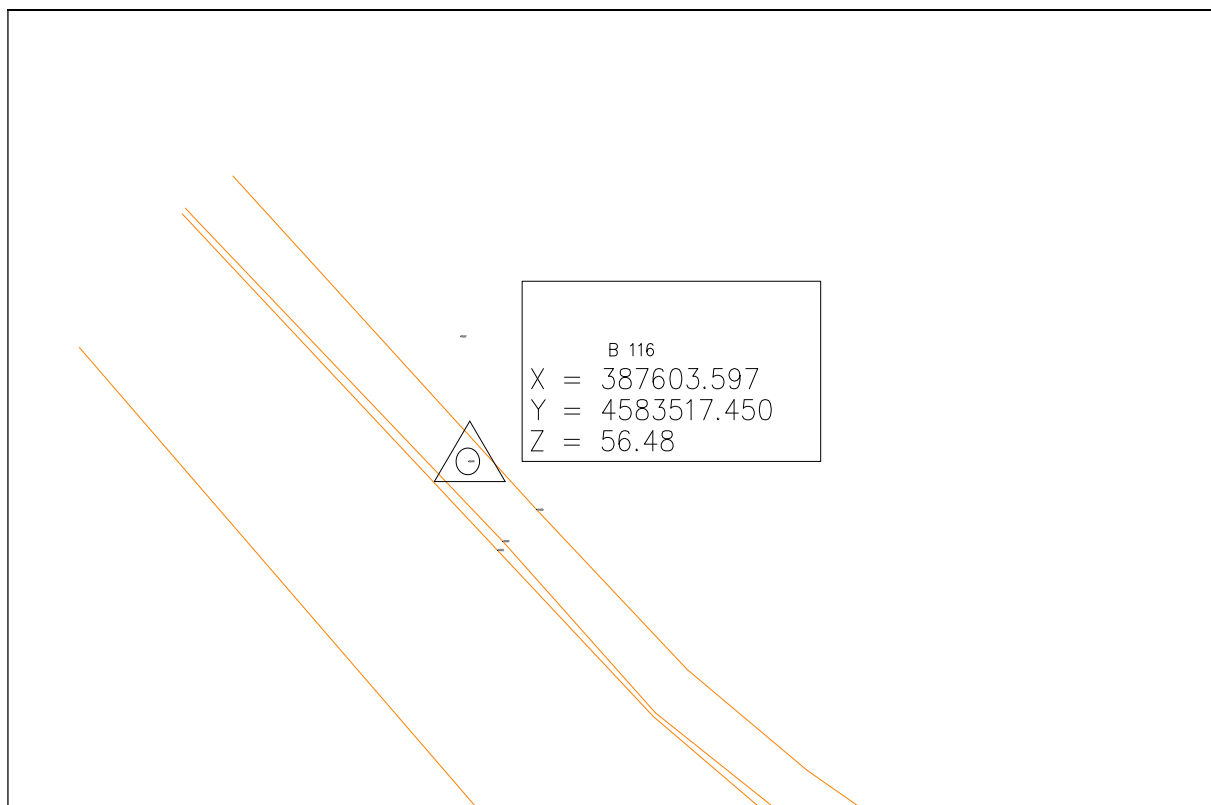

Figura38- B 117

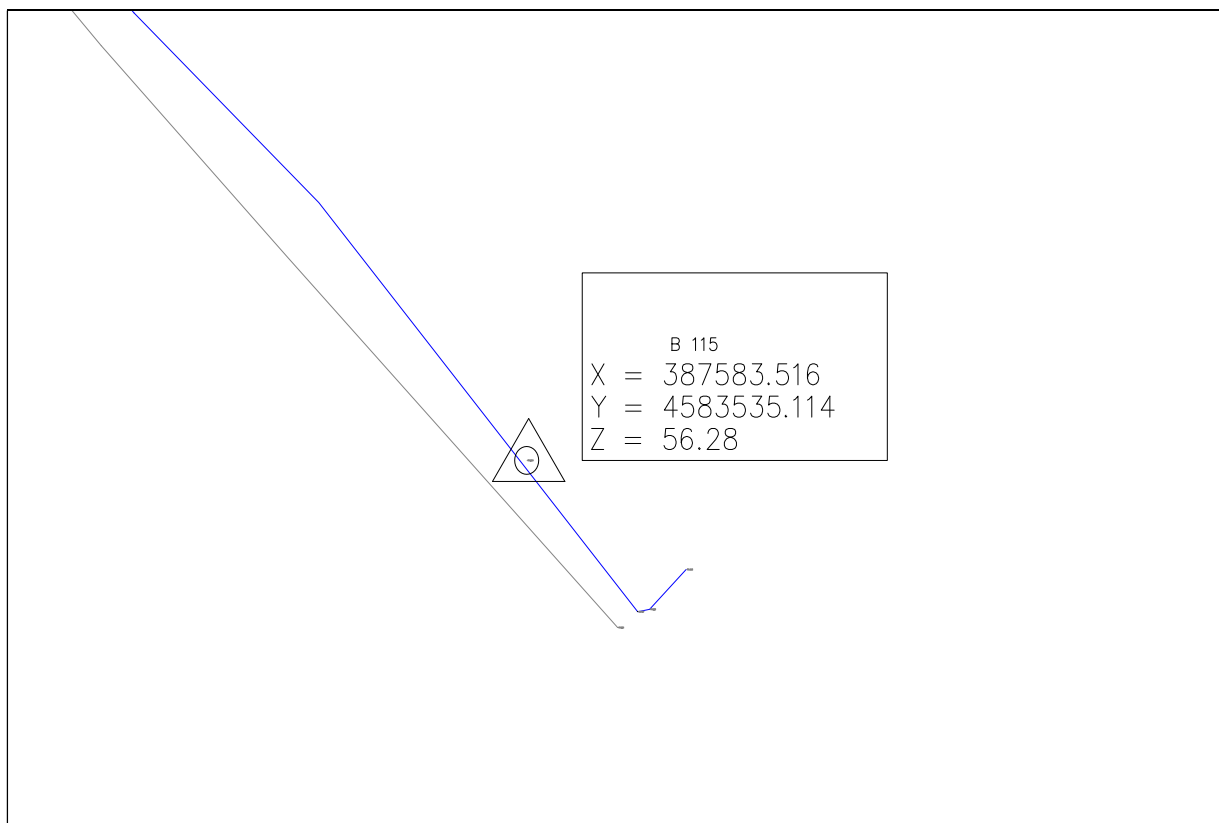

Figura 39- B 118

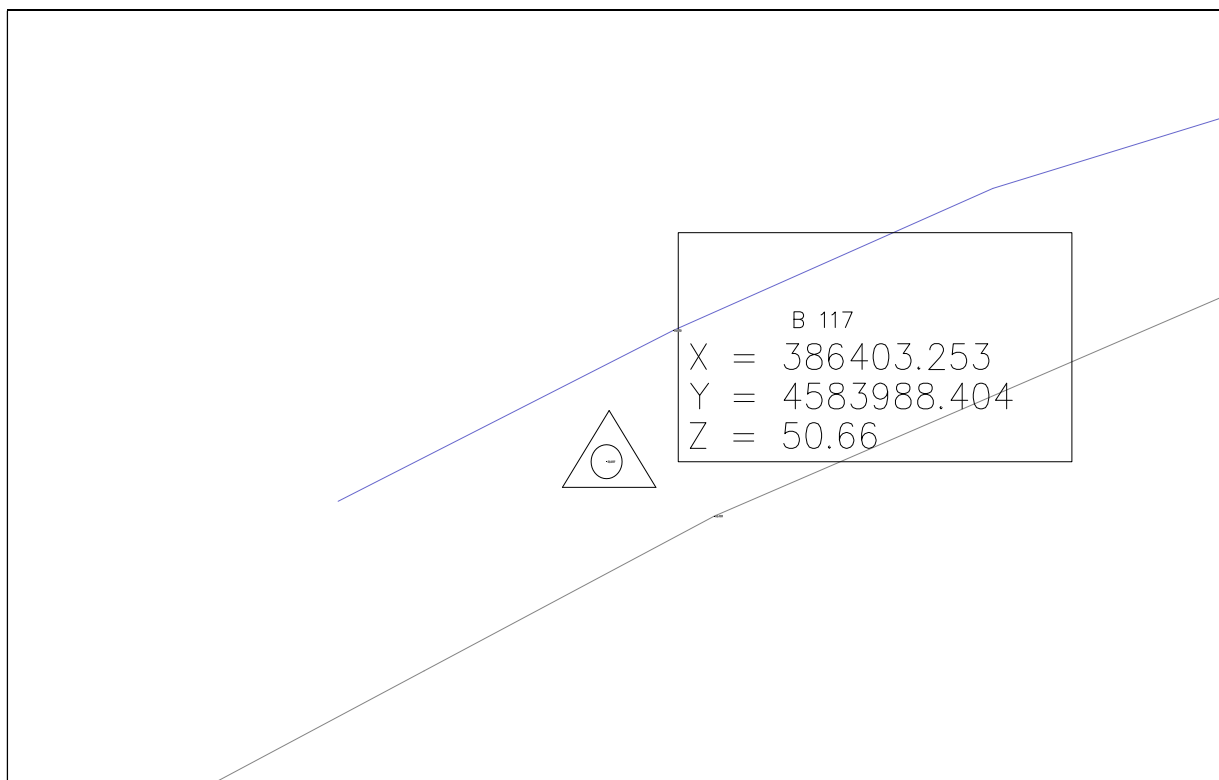

Figura 40- B 119

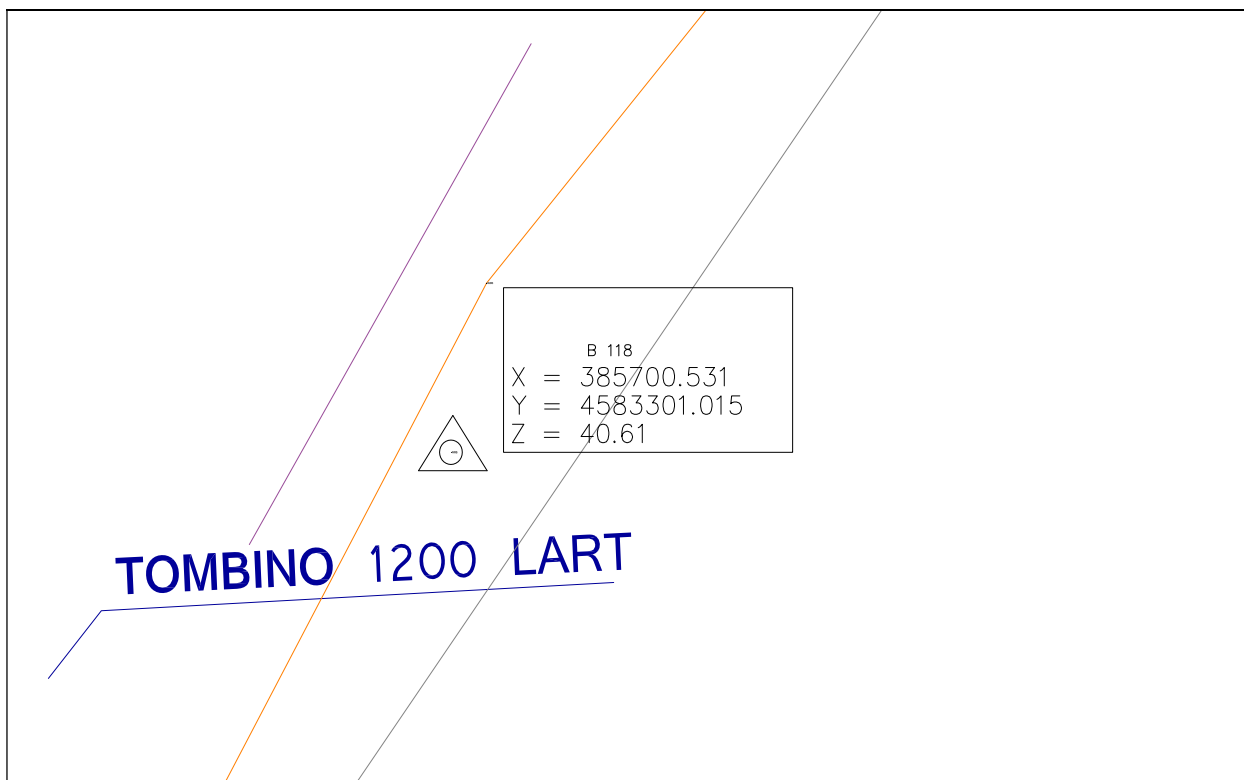

Figura 41- B 123

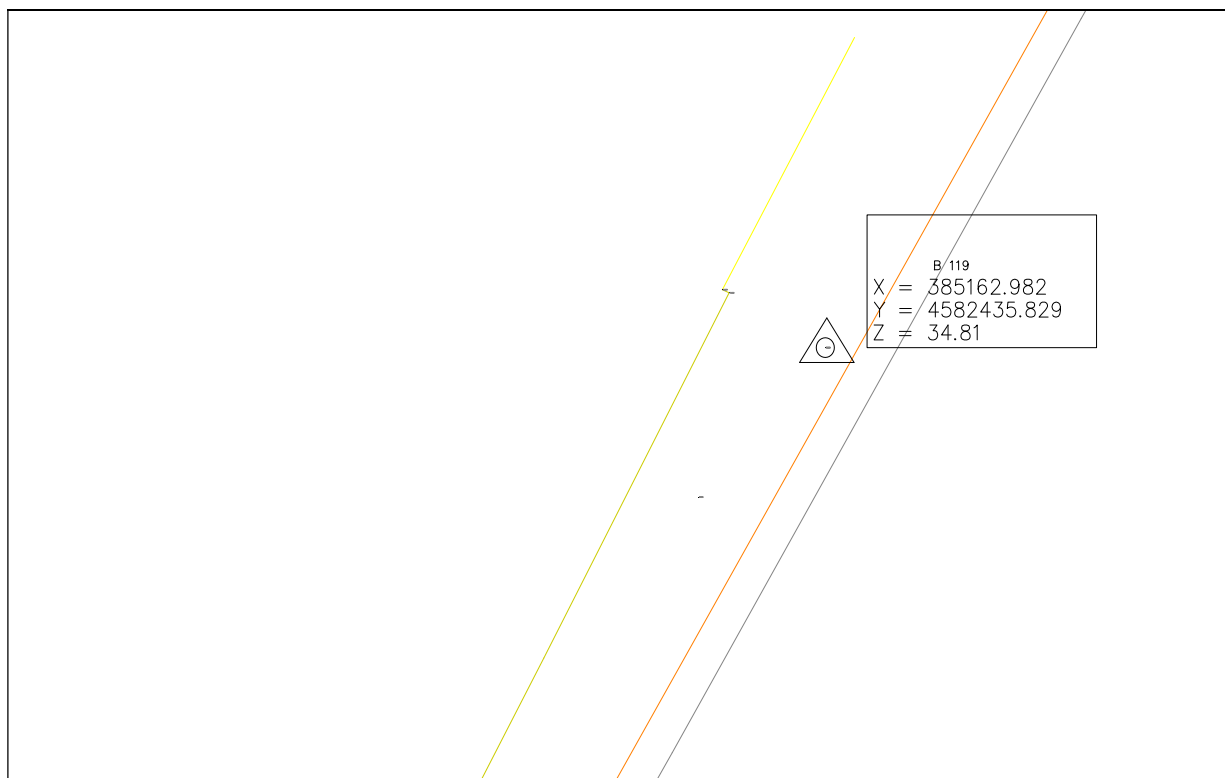

Figura 42- B 120

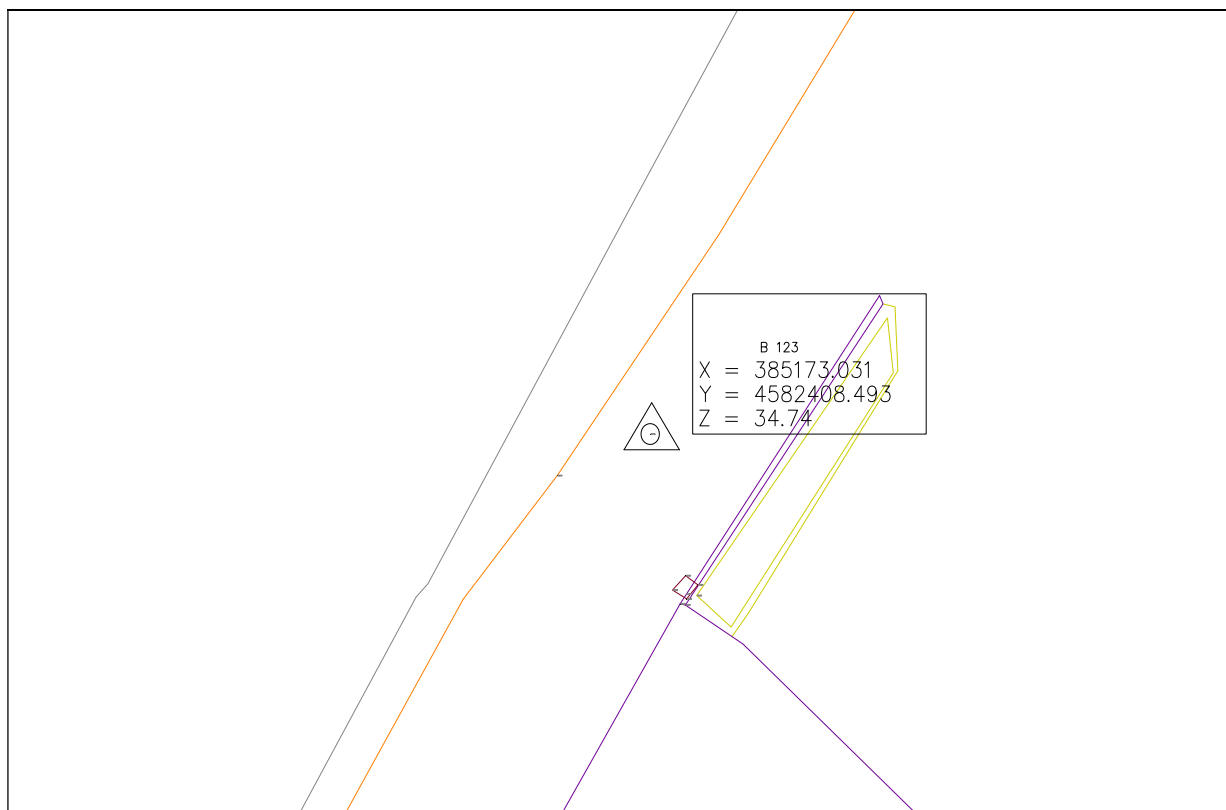

Figura 43- B 121

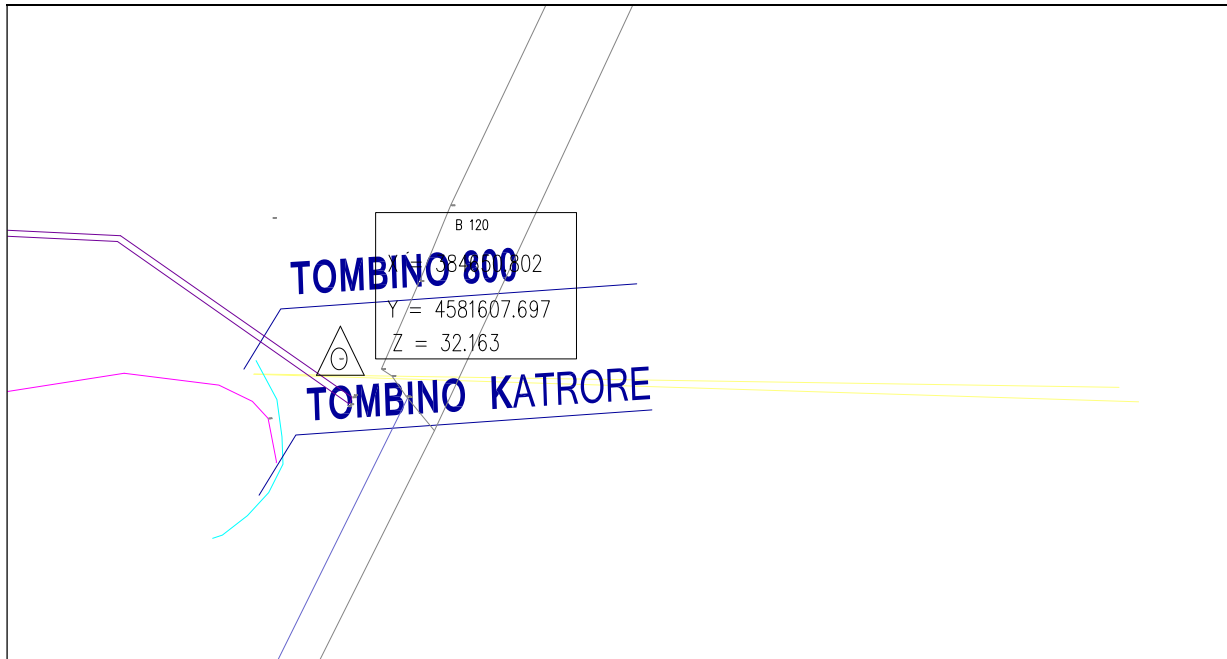

Figura 44- B 122

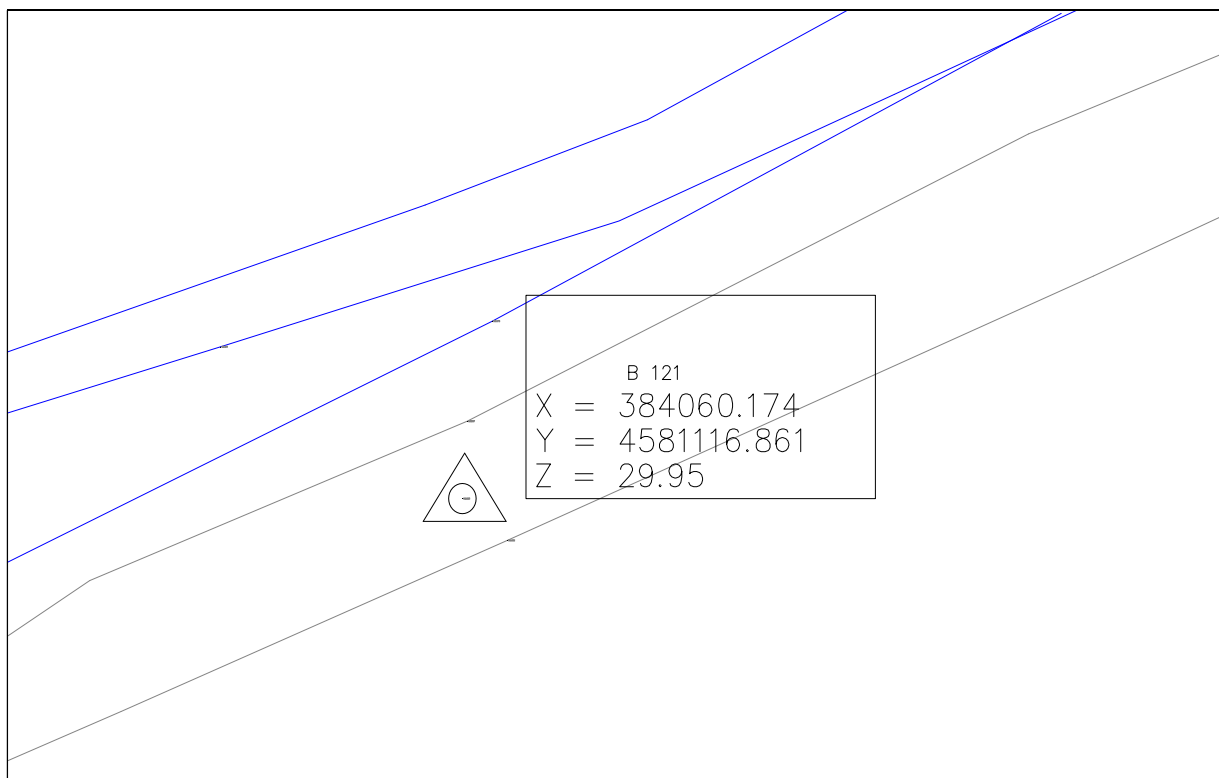

Figura 45- B 158

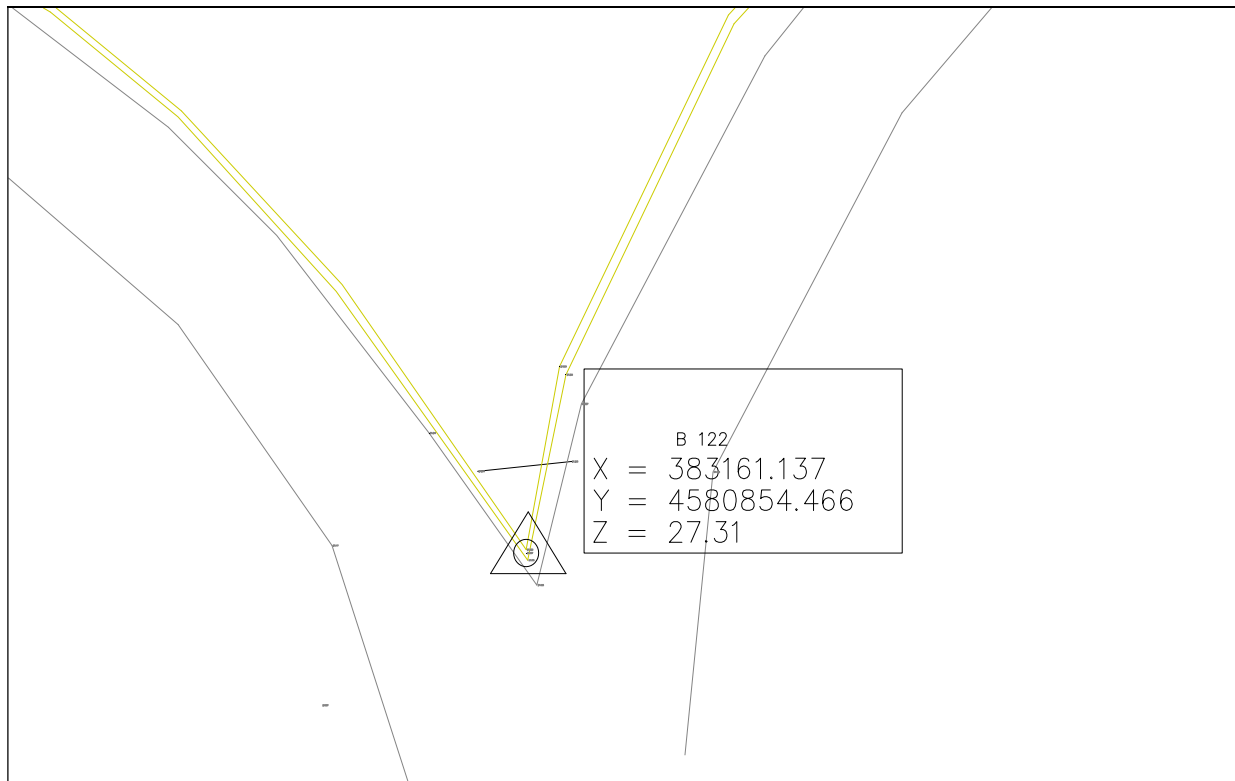

Figura46- B 157

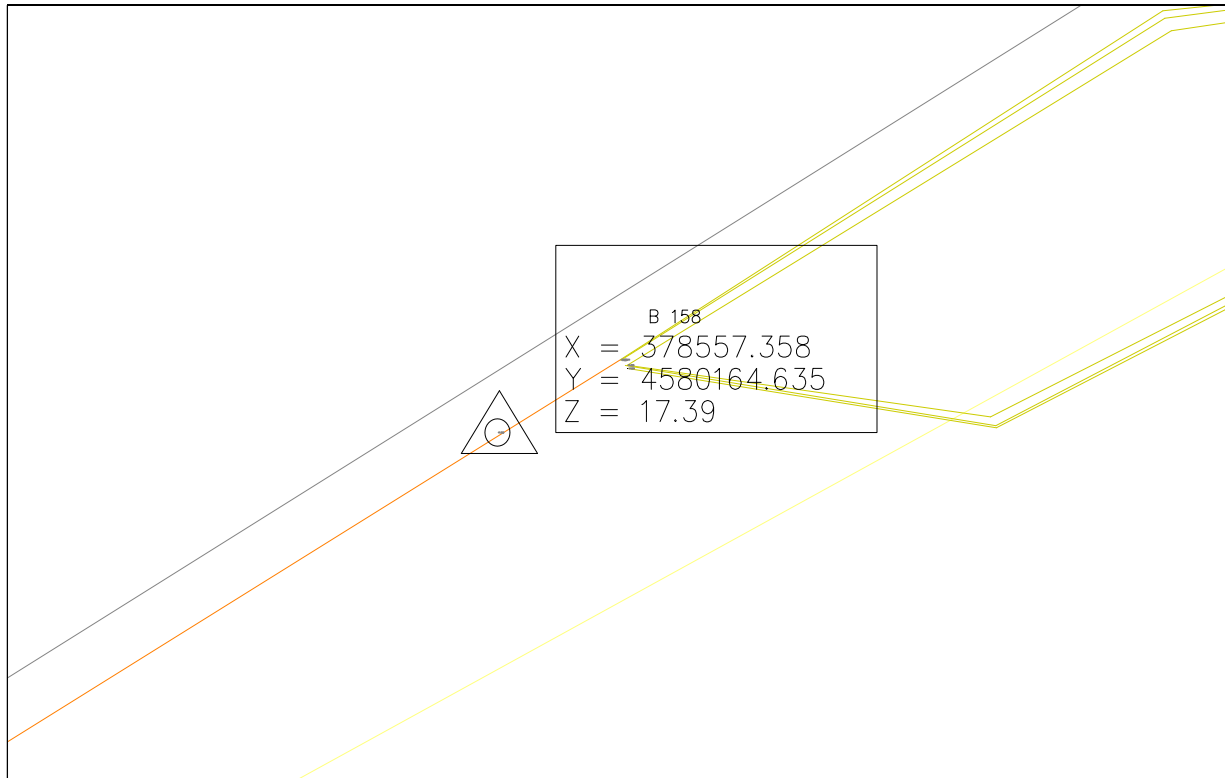

Figura 47- B 128

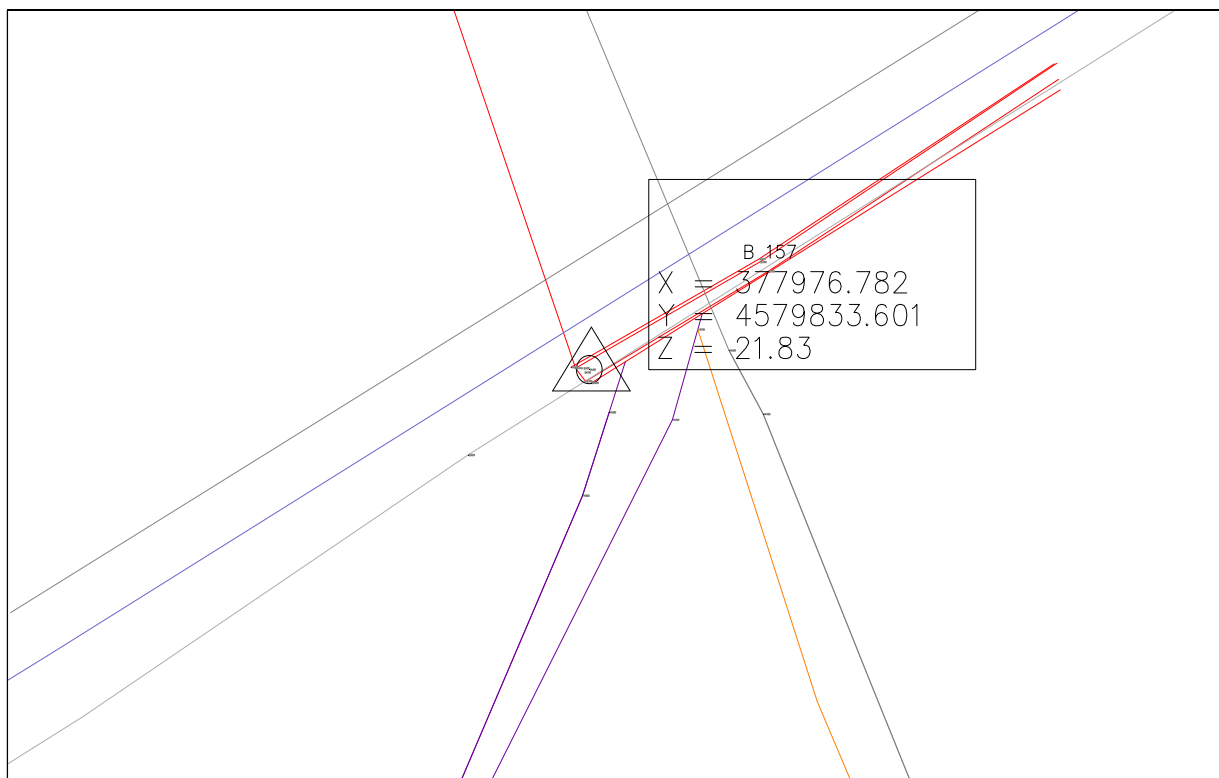

Figura 48- B 129

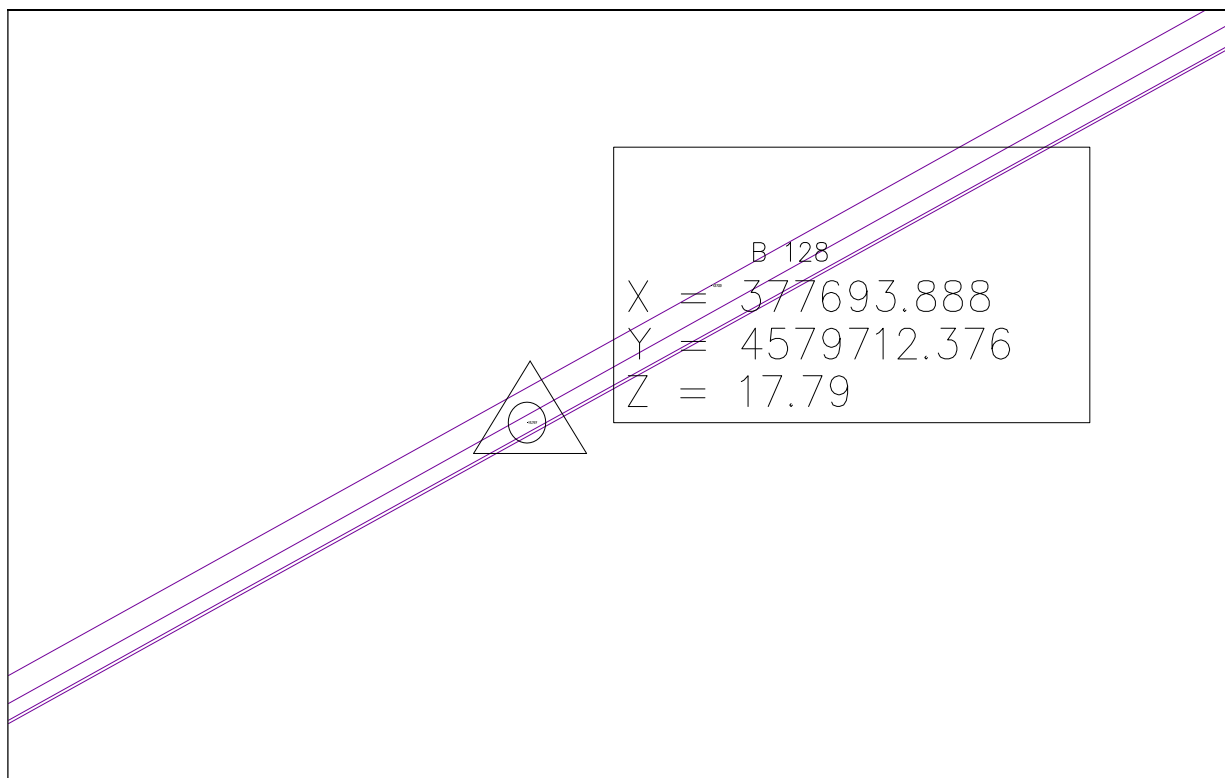

Figura 49- BM 80

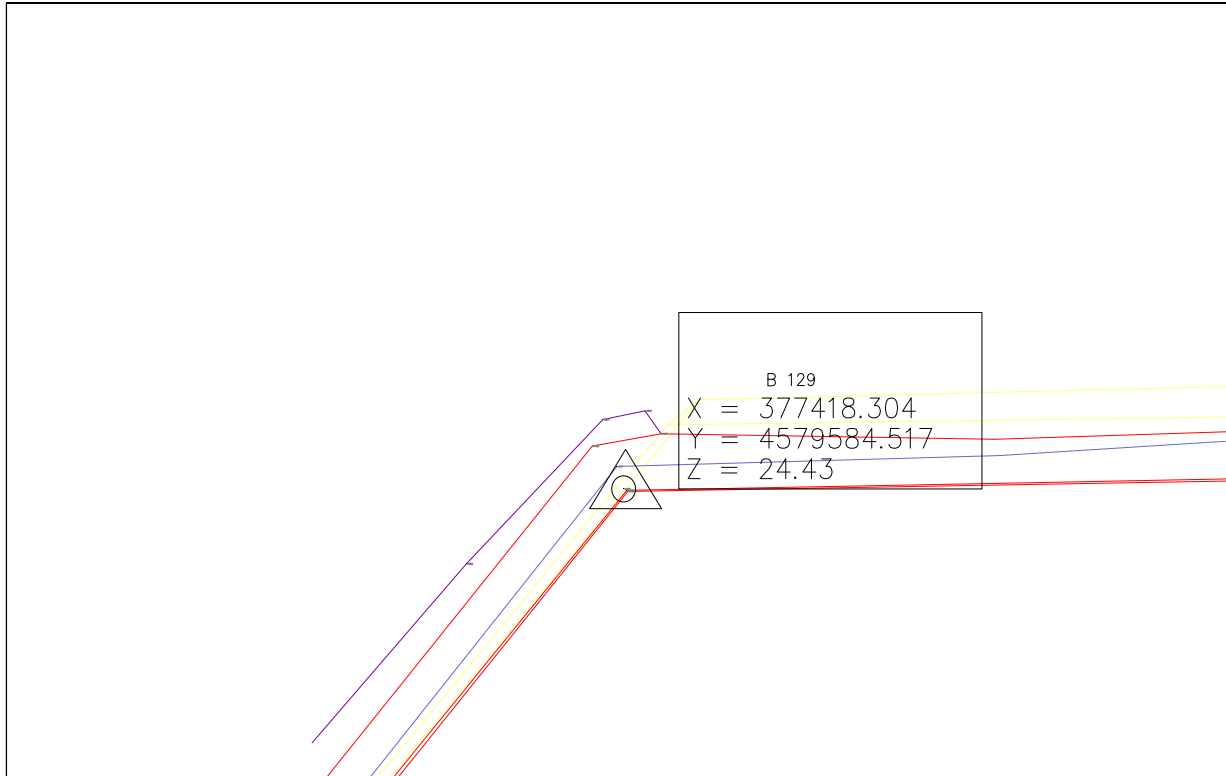

Figura50- B 130

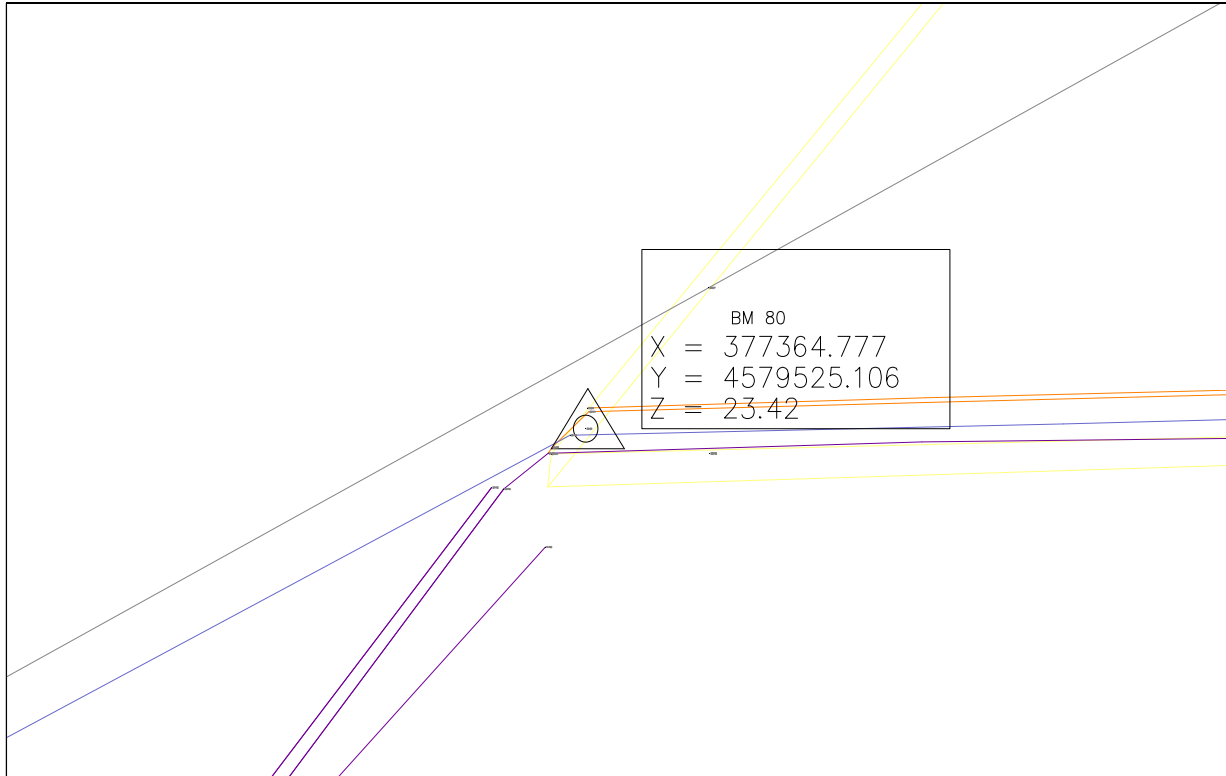

Figura 51- B 156

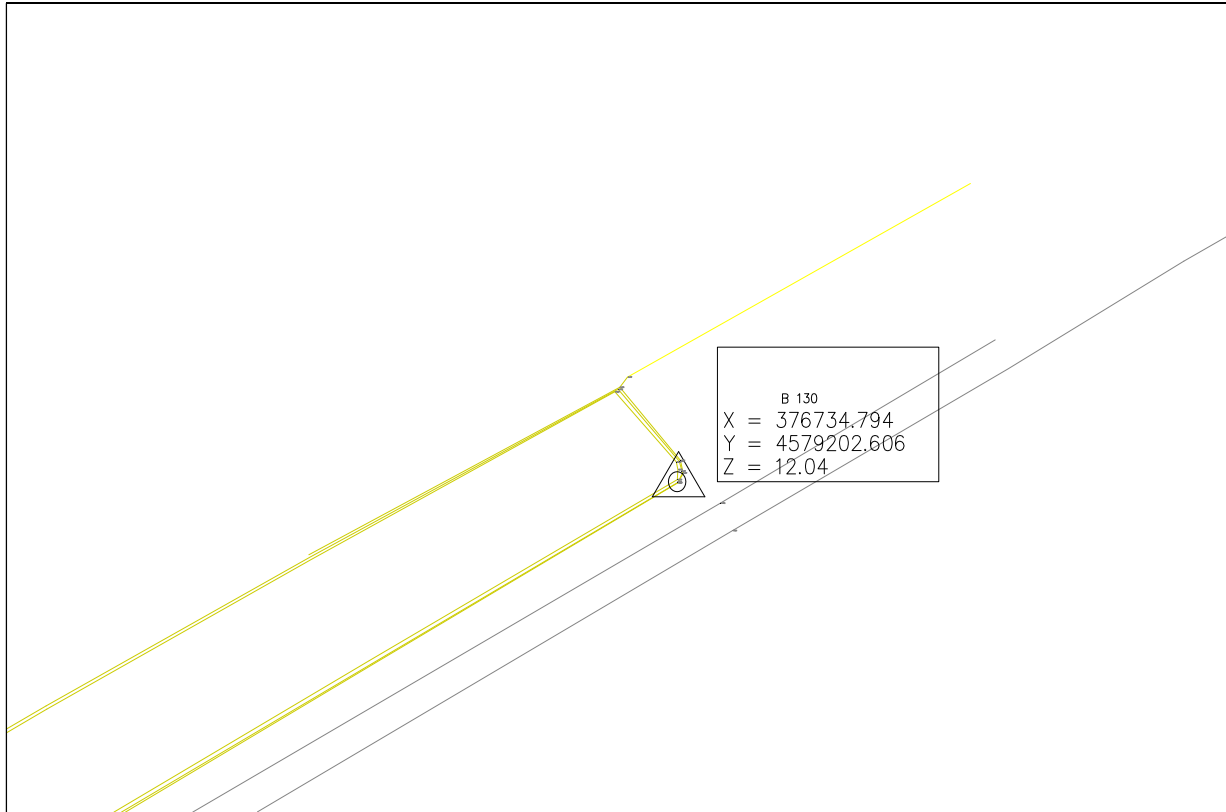

Figura 52- B 131

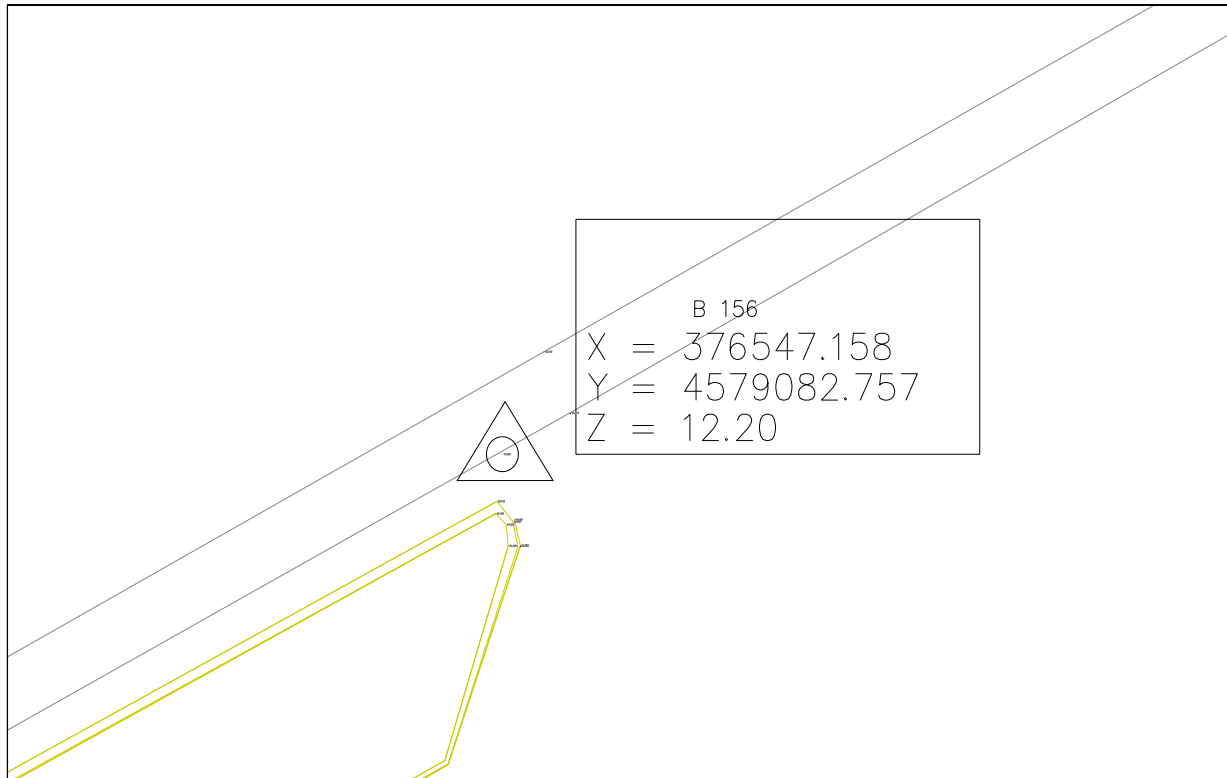

Figura 53- B 155

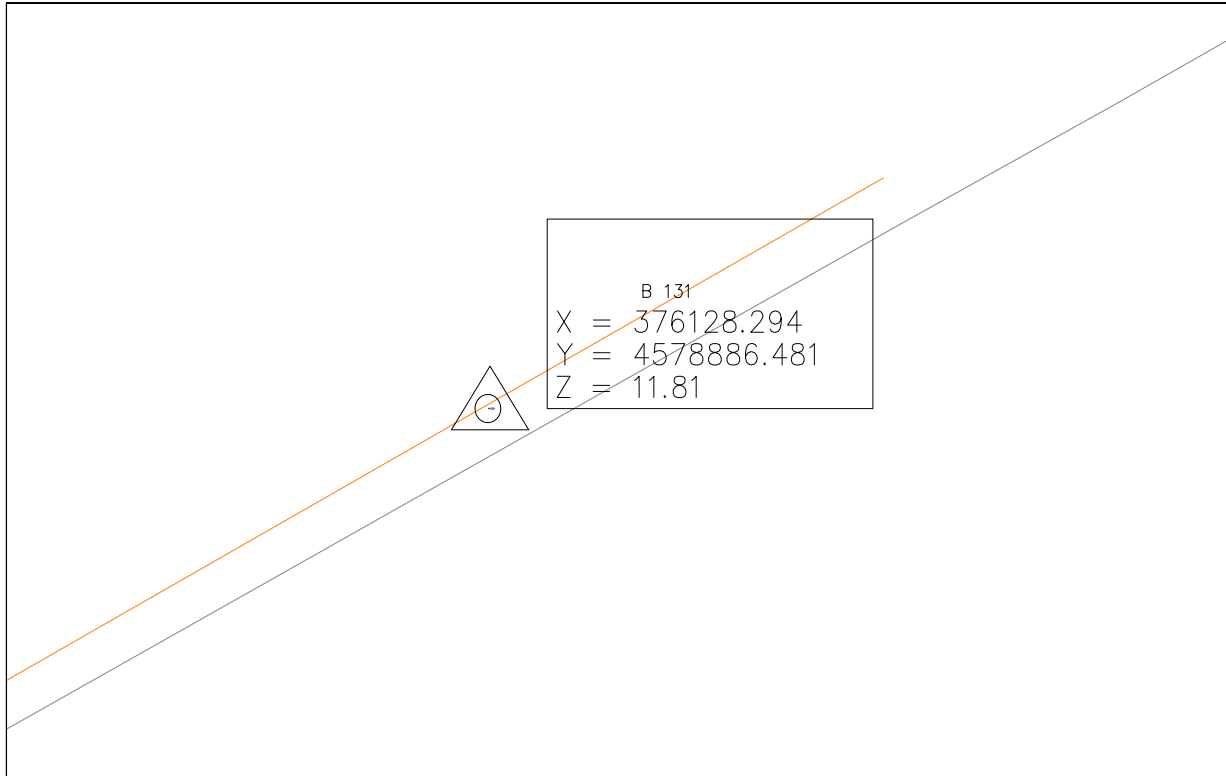

Figura 54- B 132

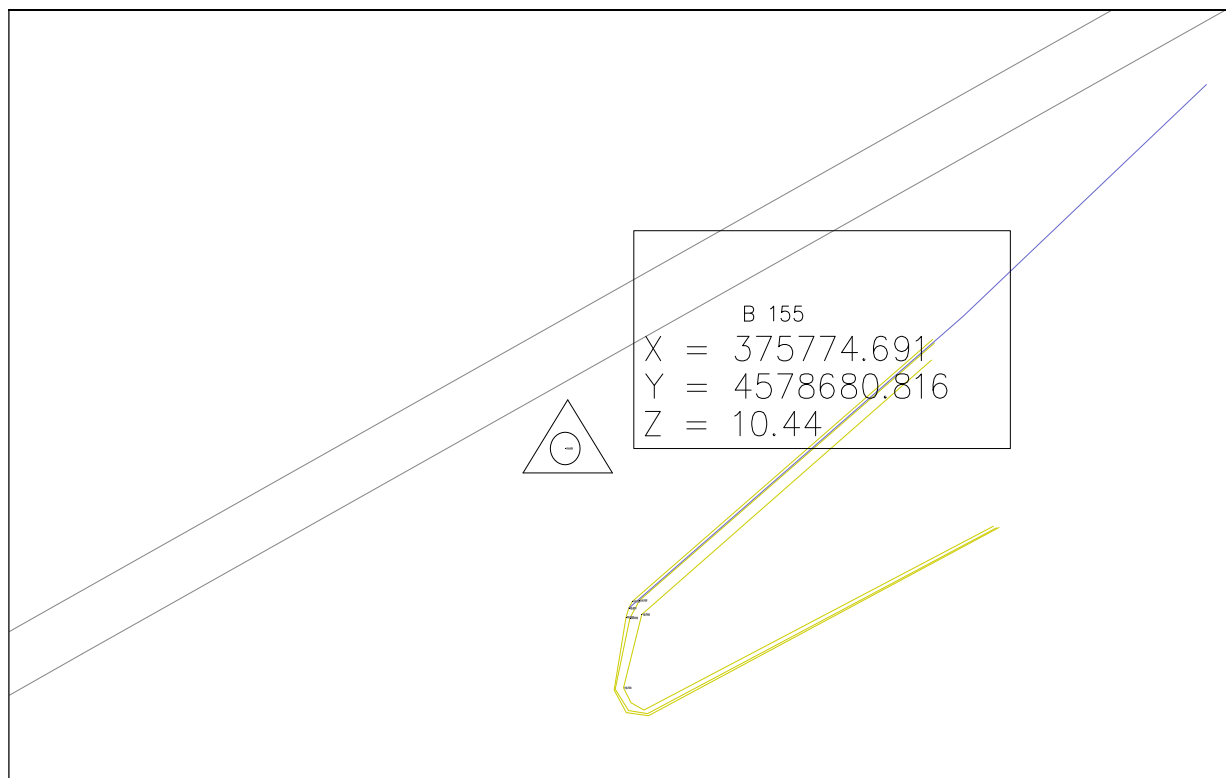

Figura 55- B 133

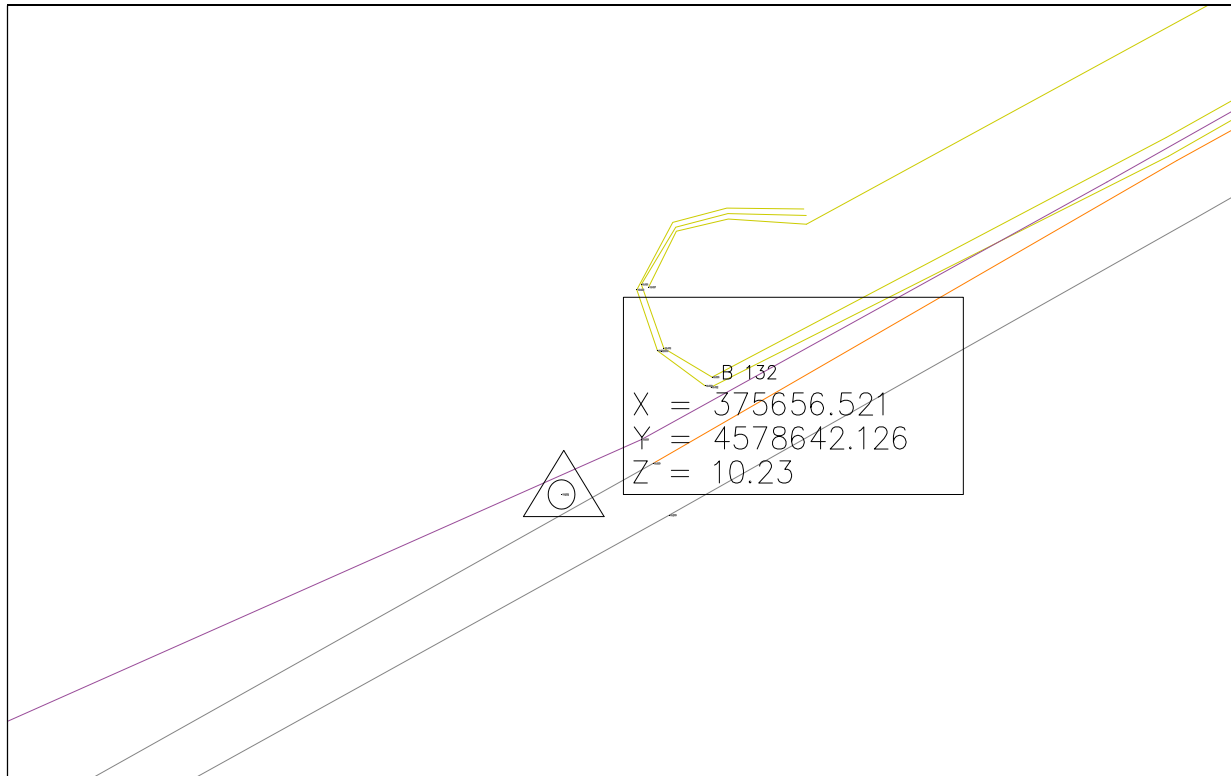

Figura 56- B 154

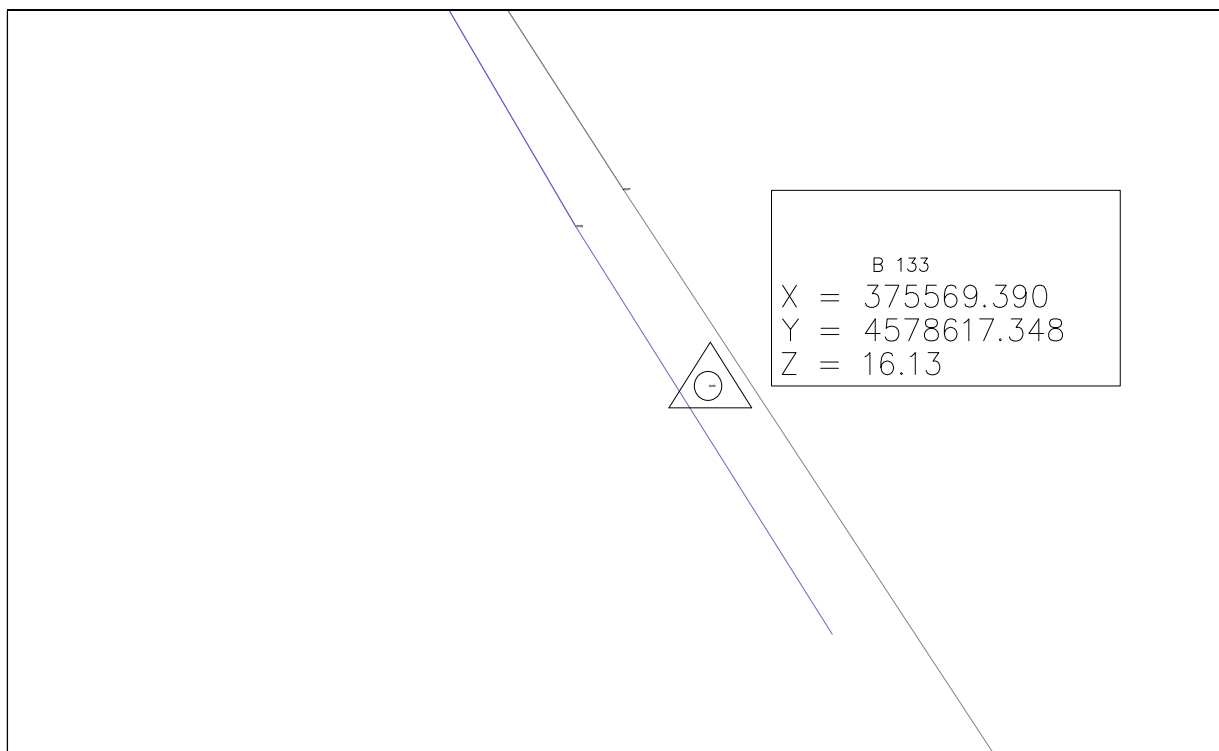

Figura 57- B 134, B 203

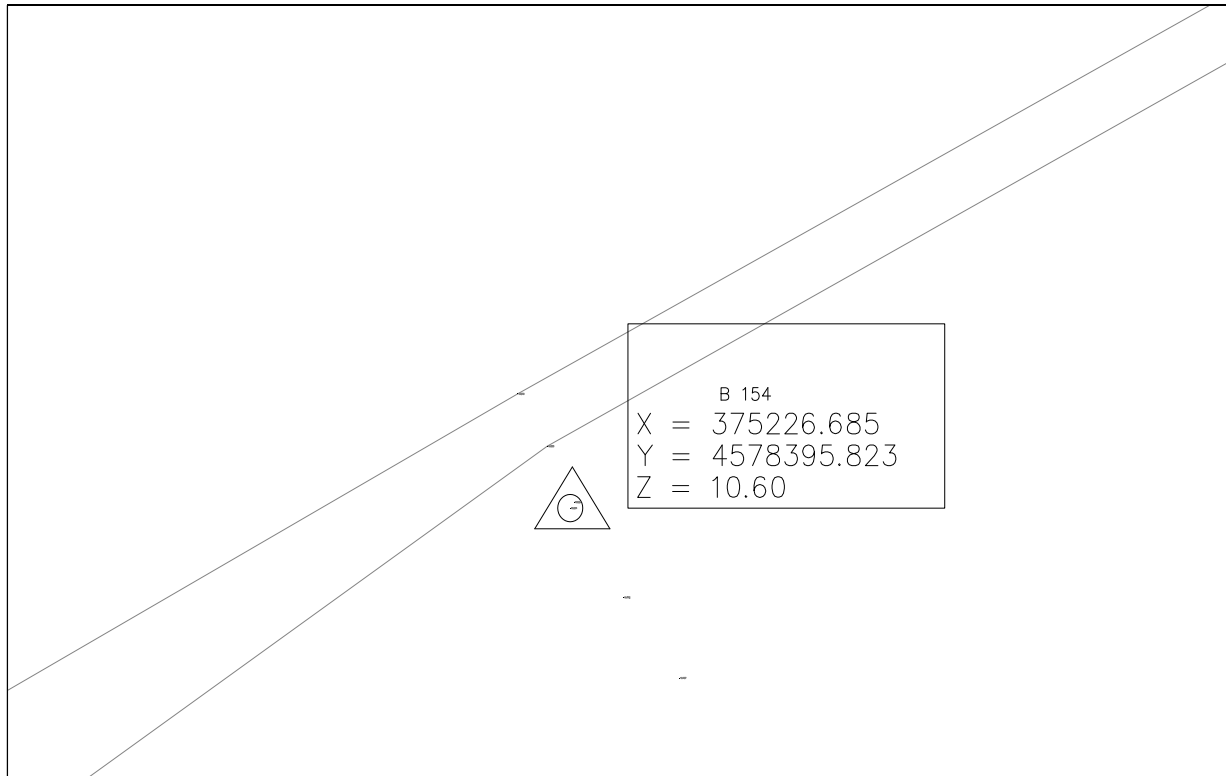

Figura 58- B 135

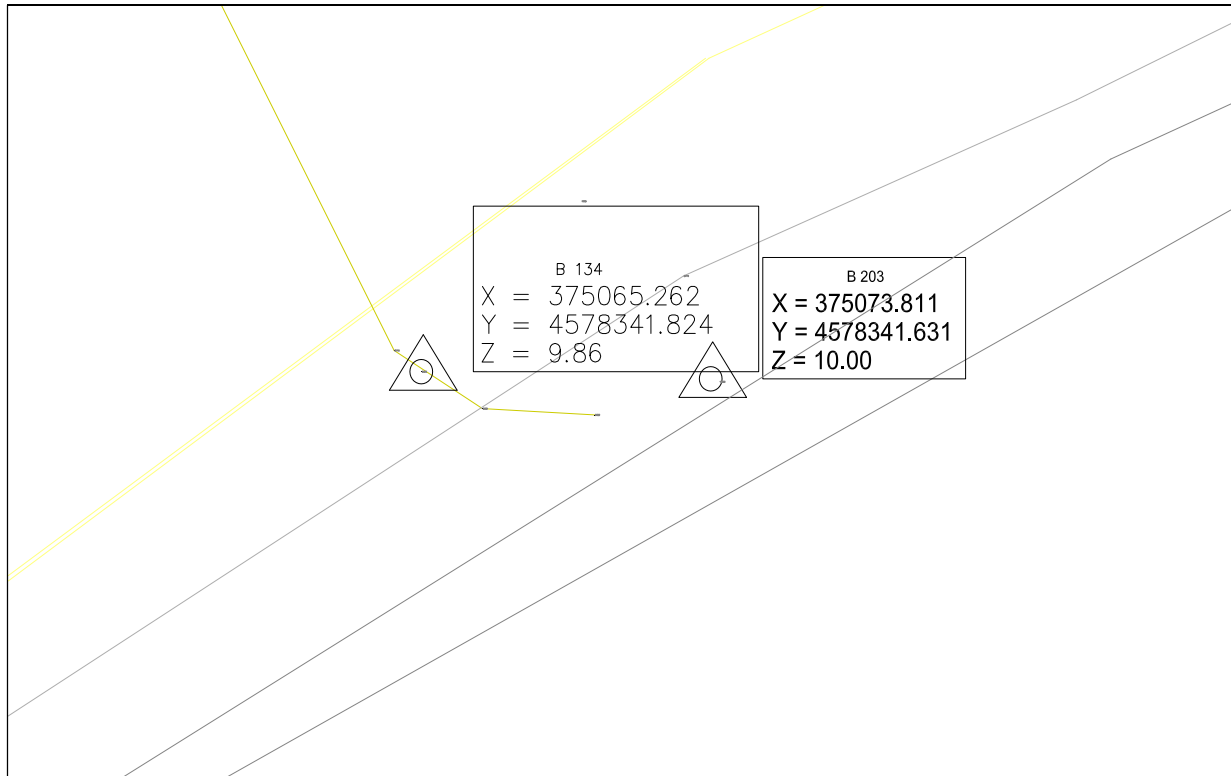

Figura 59- B 152

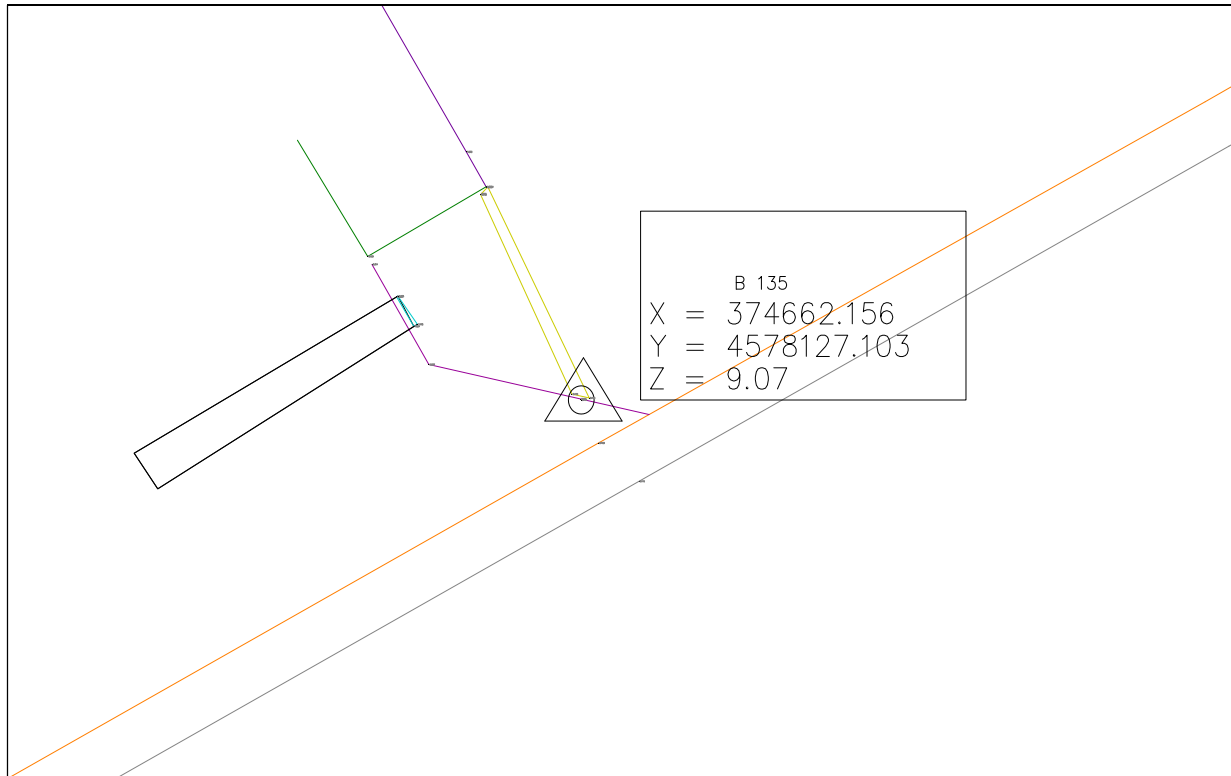

Figura 60- B 136

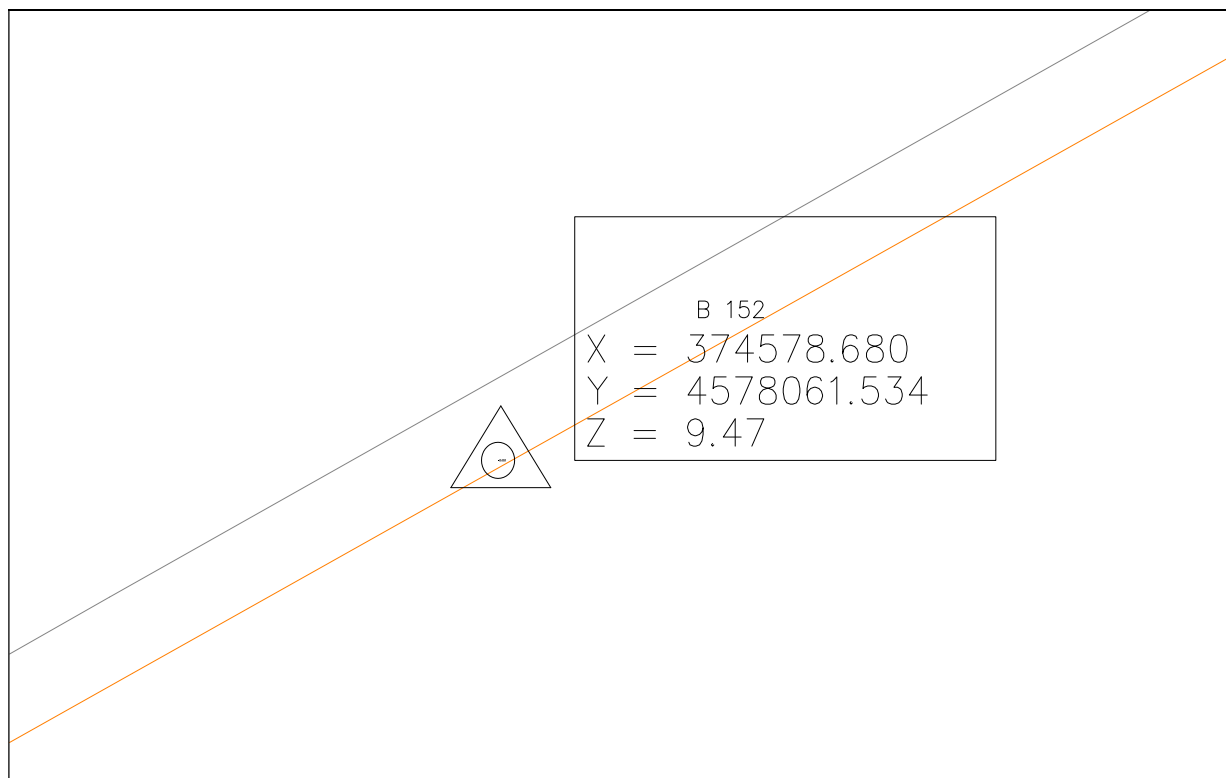

Figura 61- B 151

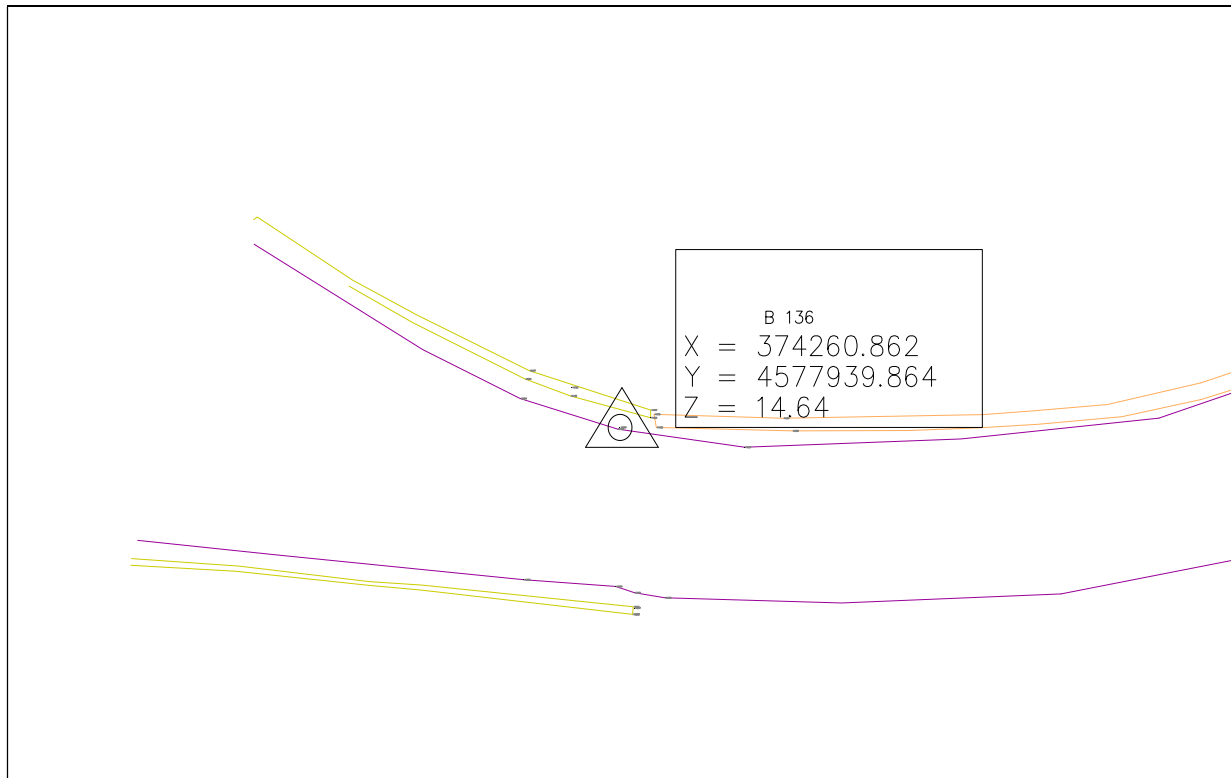

Figura 62- B 137

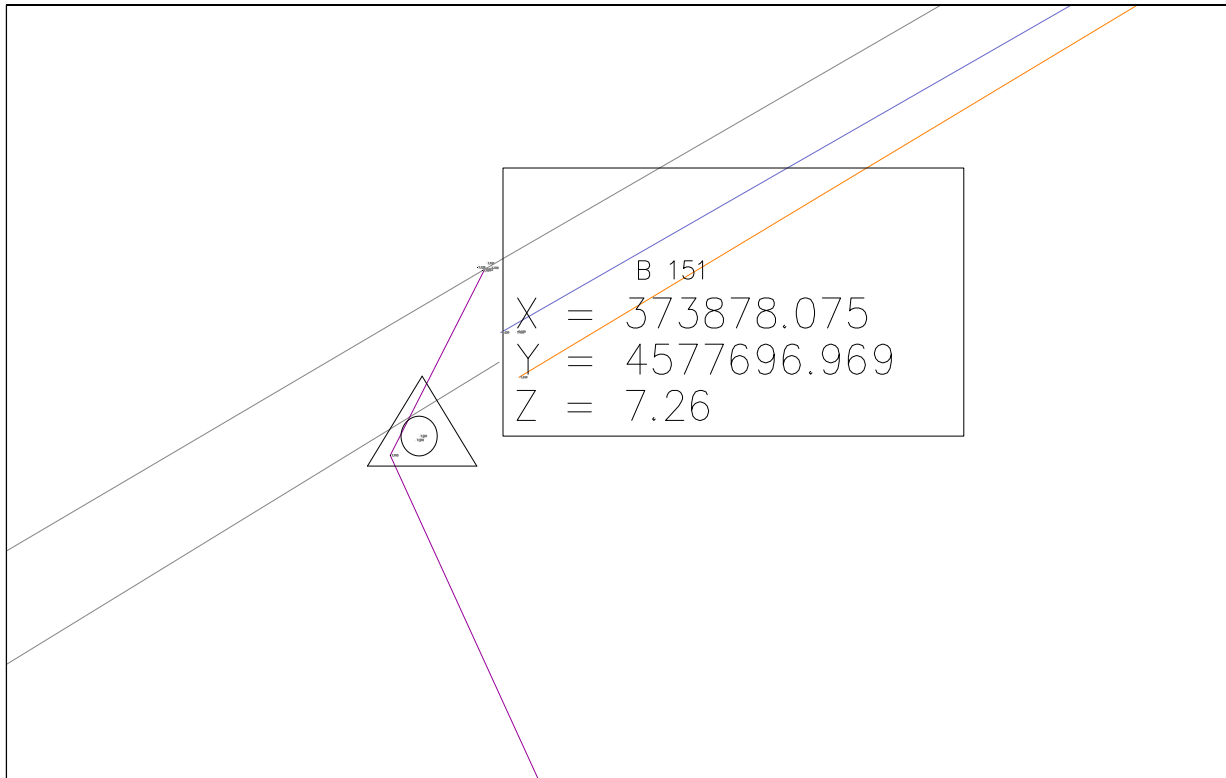

Figura 63- B 138



Figura 64- B 150

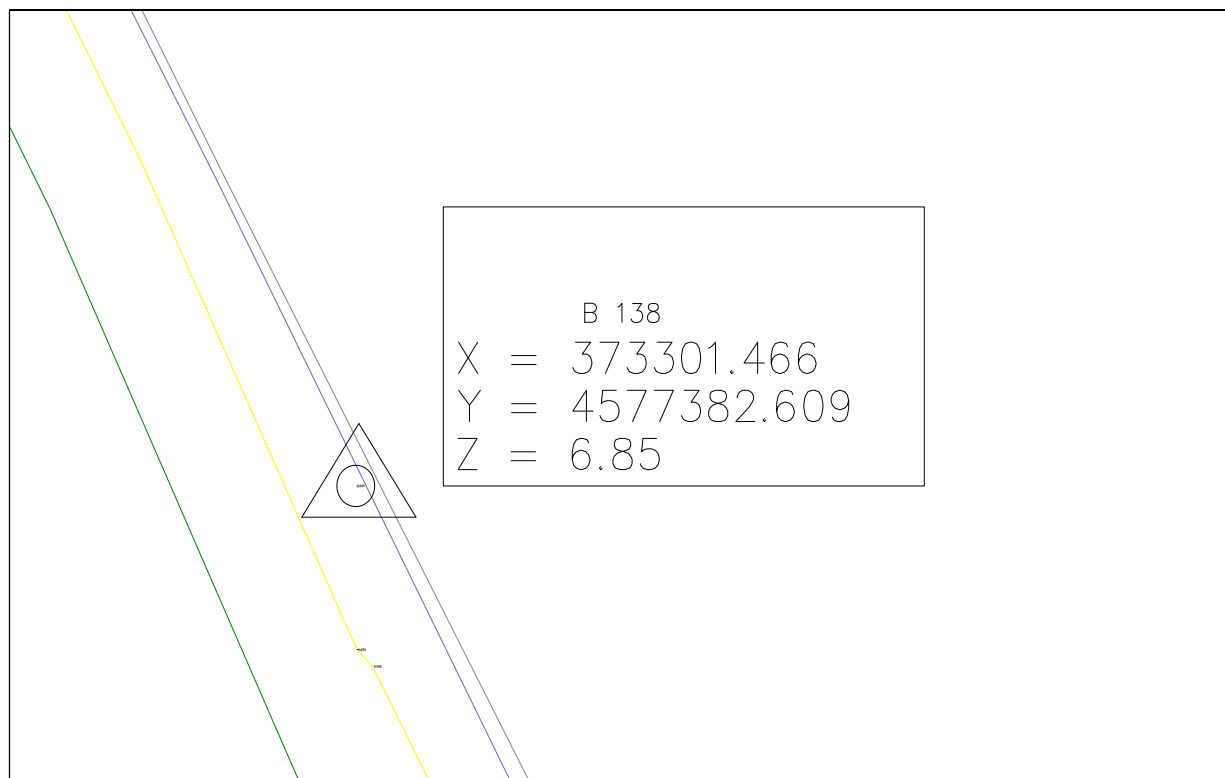

Figura 65- B 139

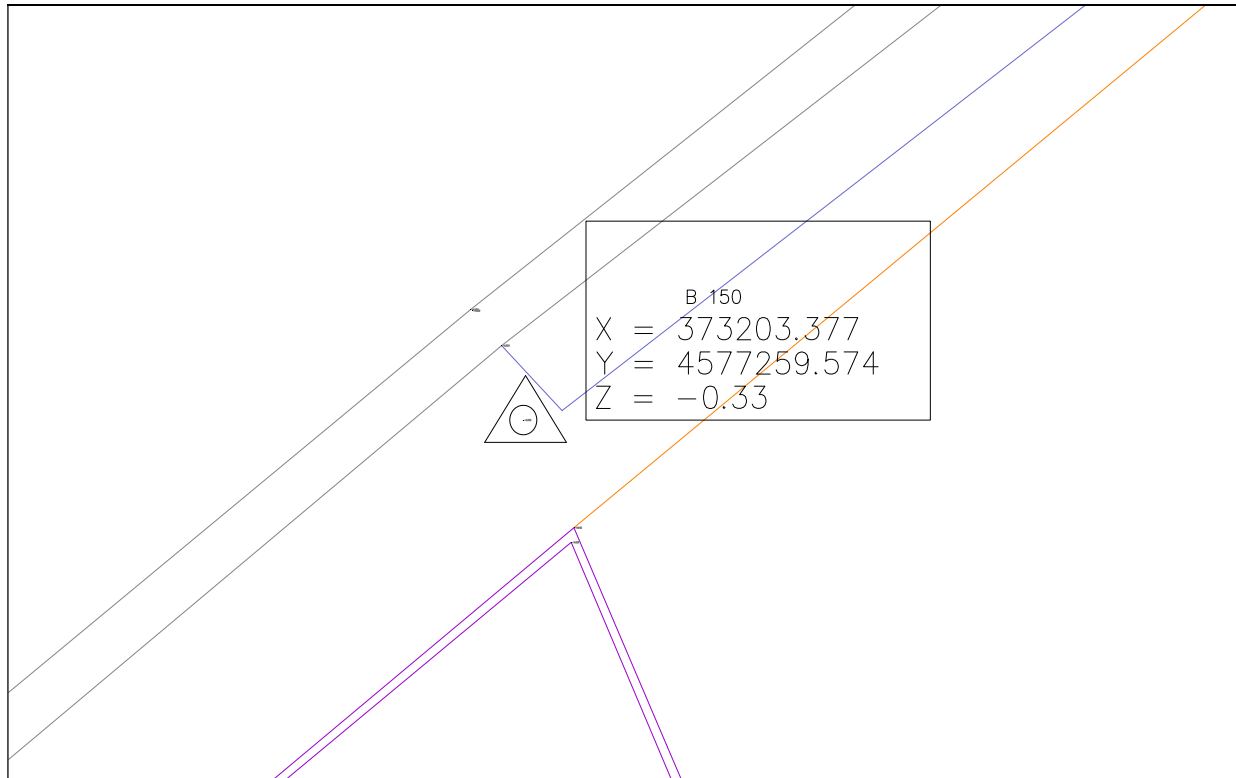

Figura 66- B 149

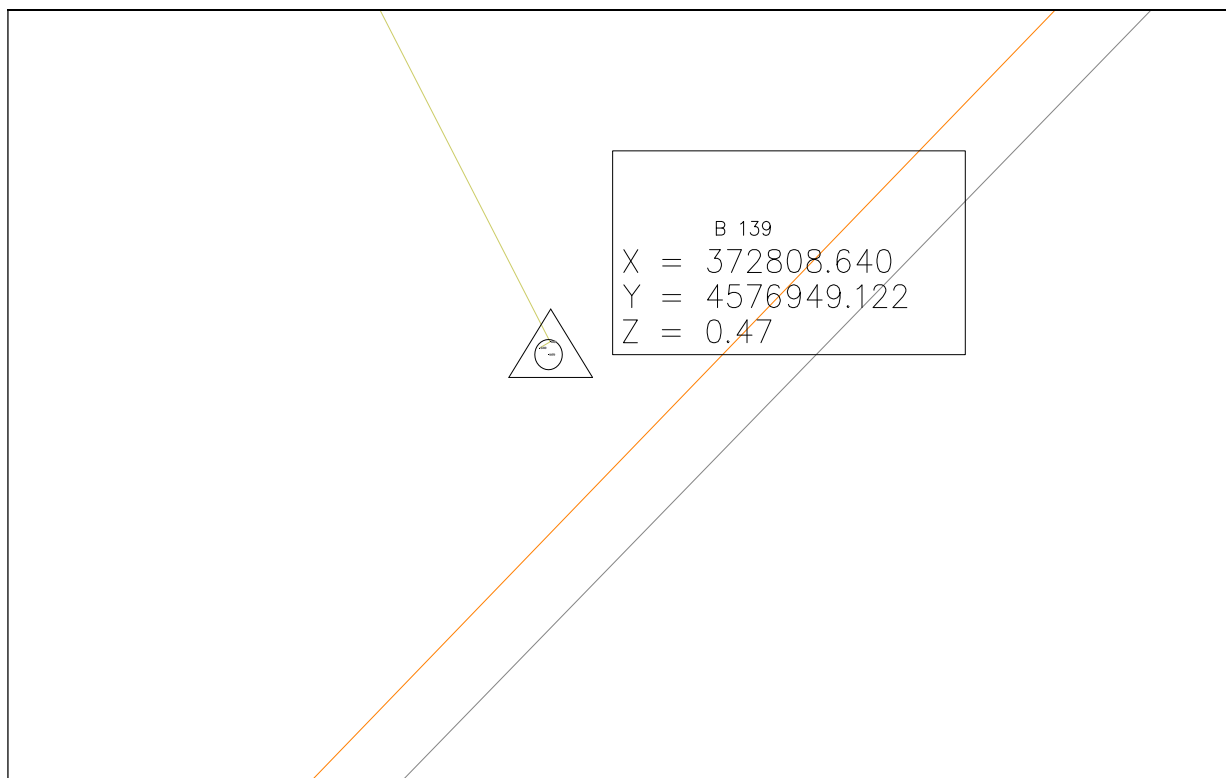

Figura 67- B 140

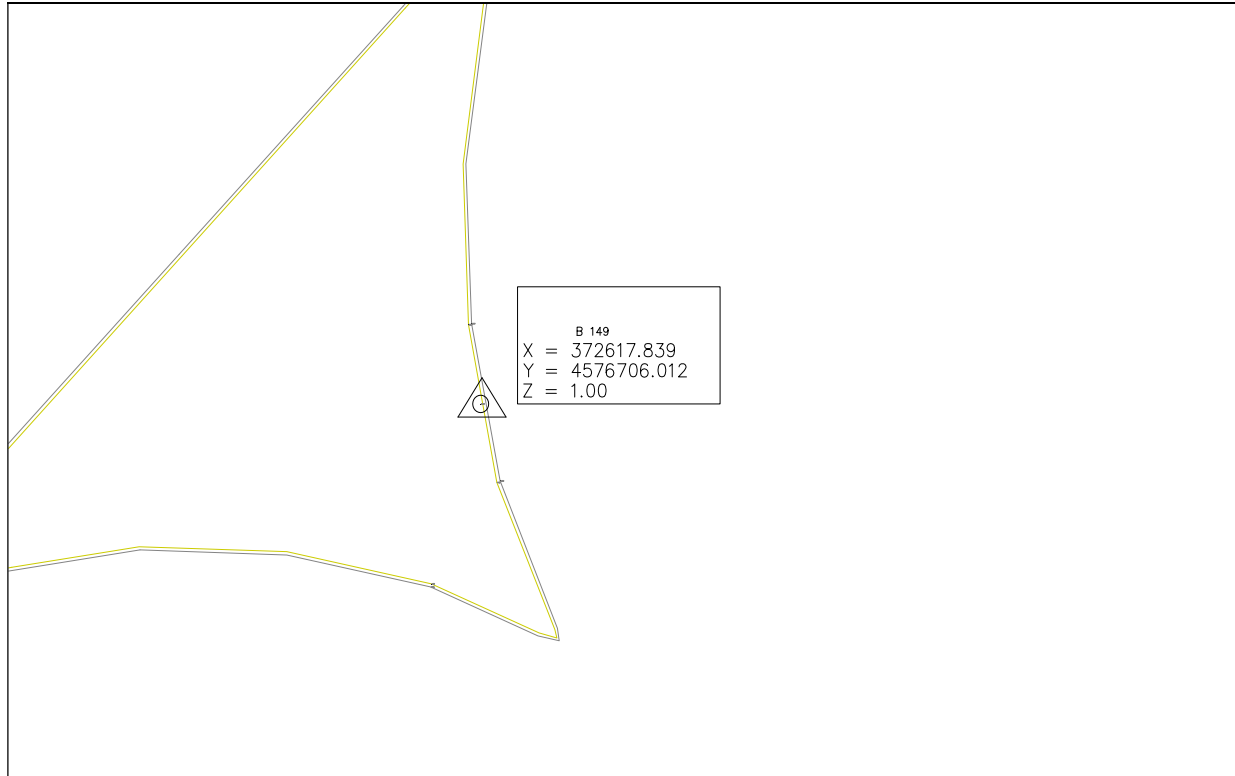

Figura 68- B 148

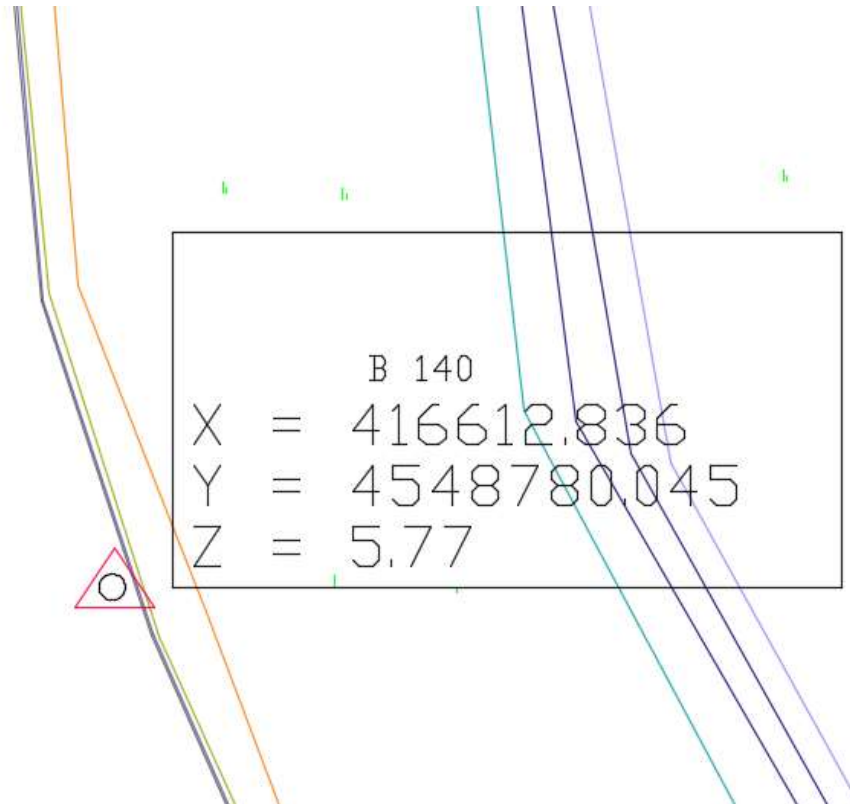

Figura 69- B 141

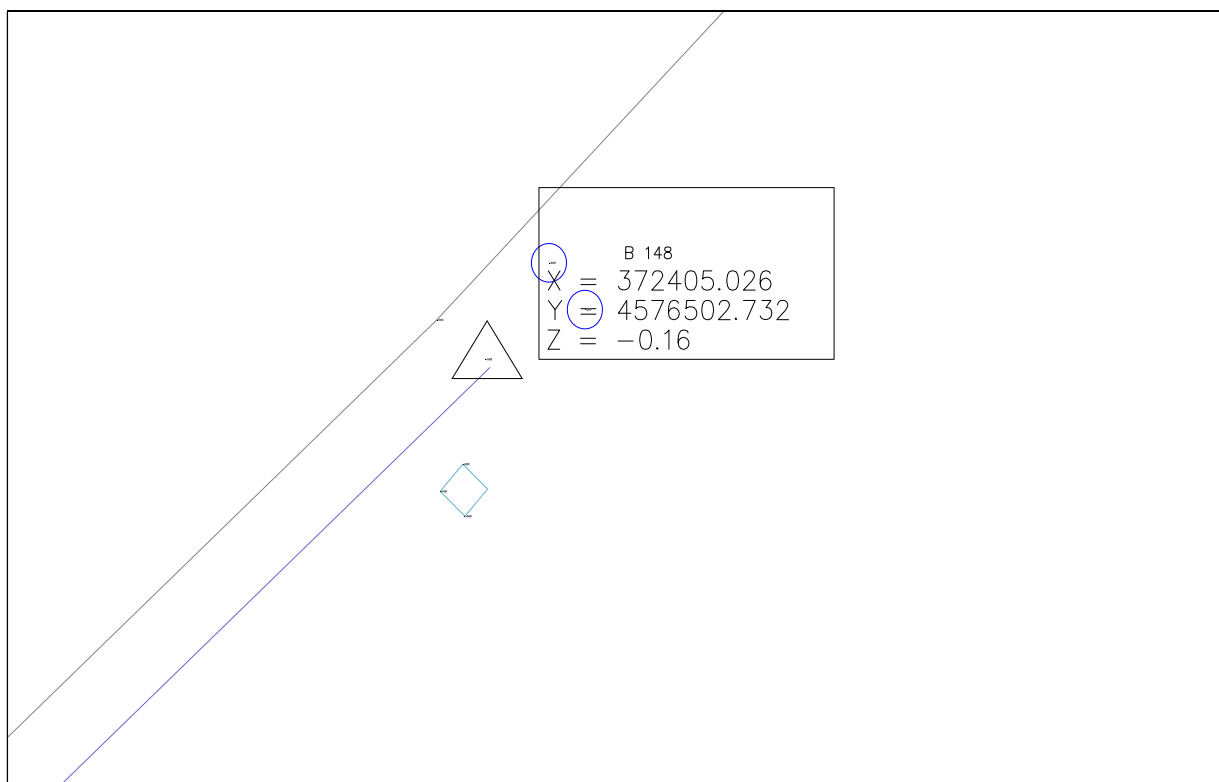

Figura 70- B 147

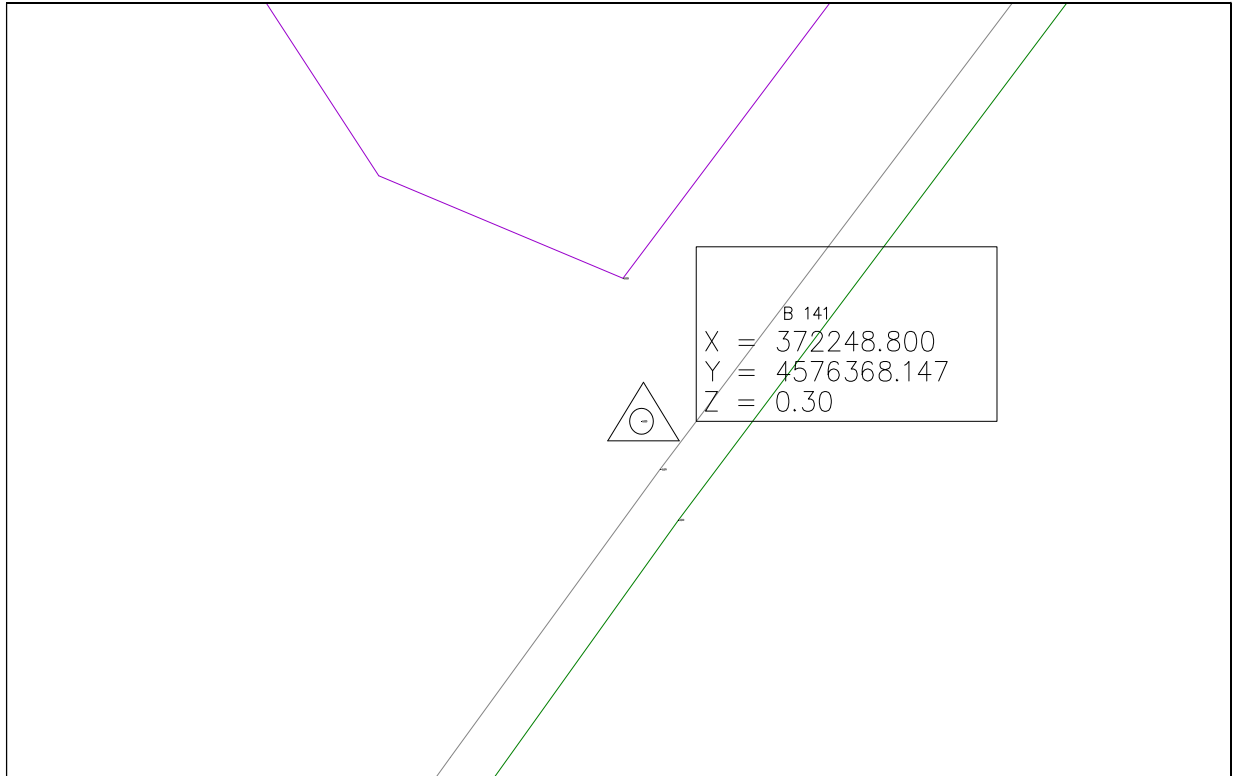

Figura 71- B 142

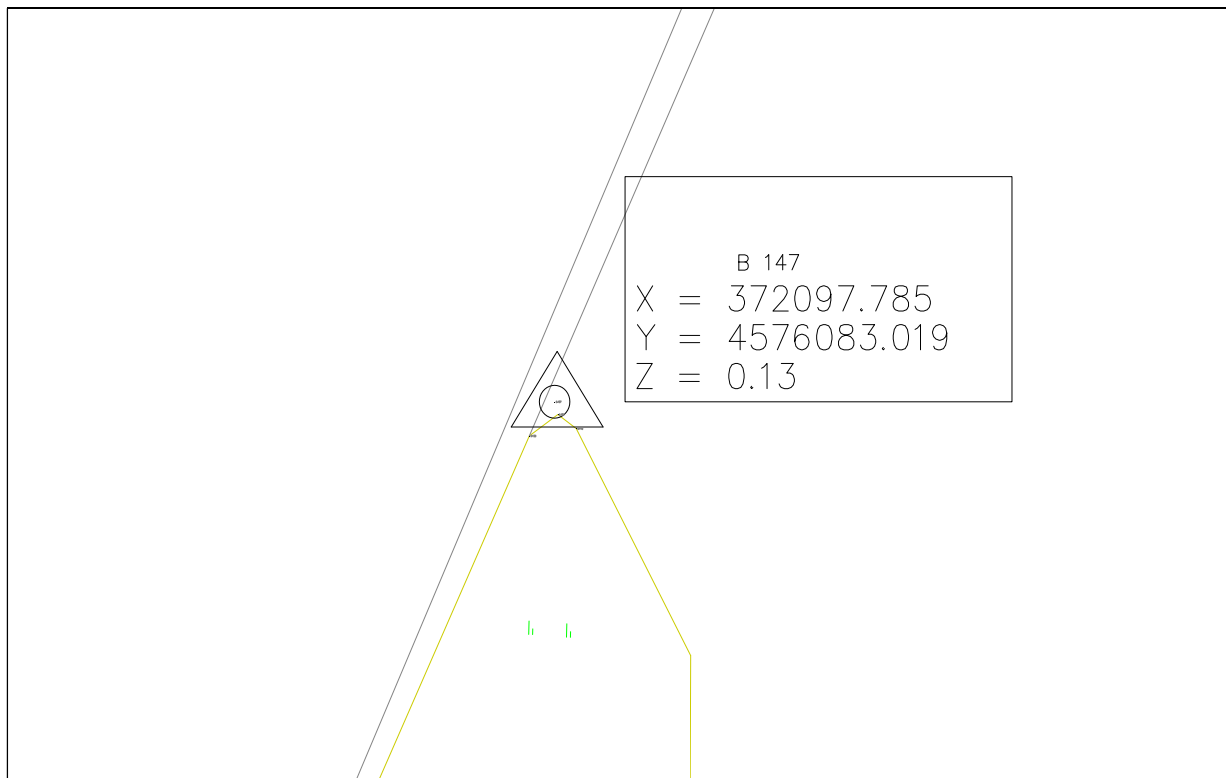

Figura 72- B 146

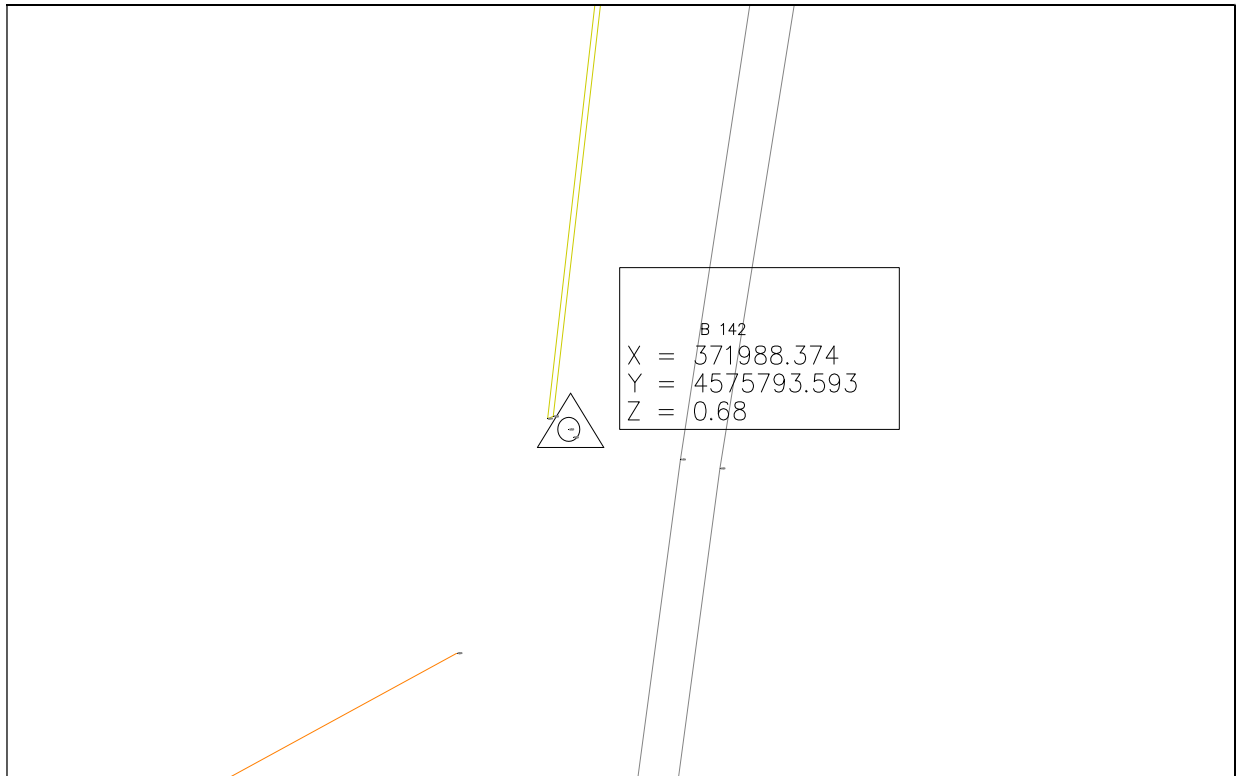

Figura 73- B 145

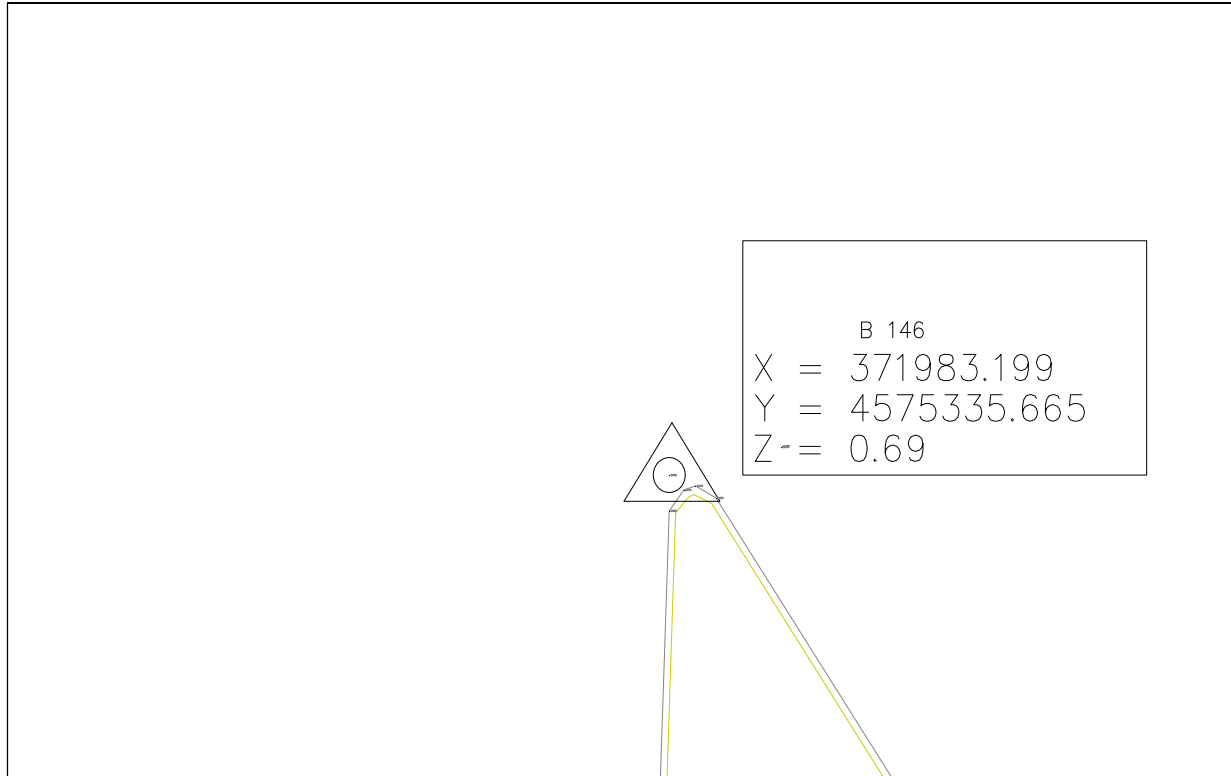

Figura 74- B 144

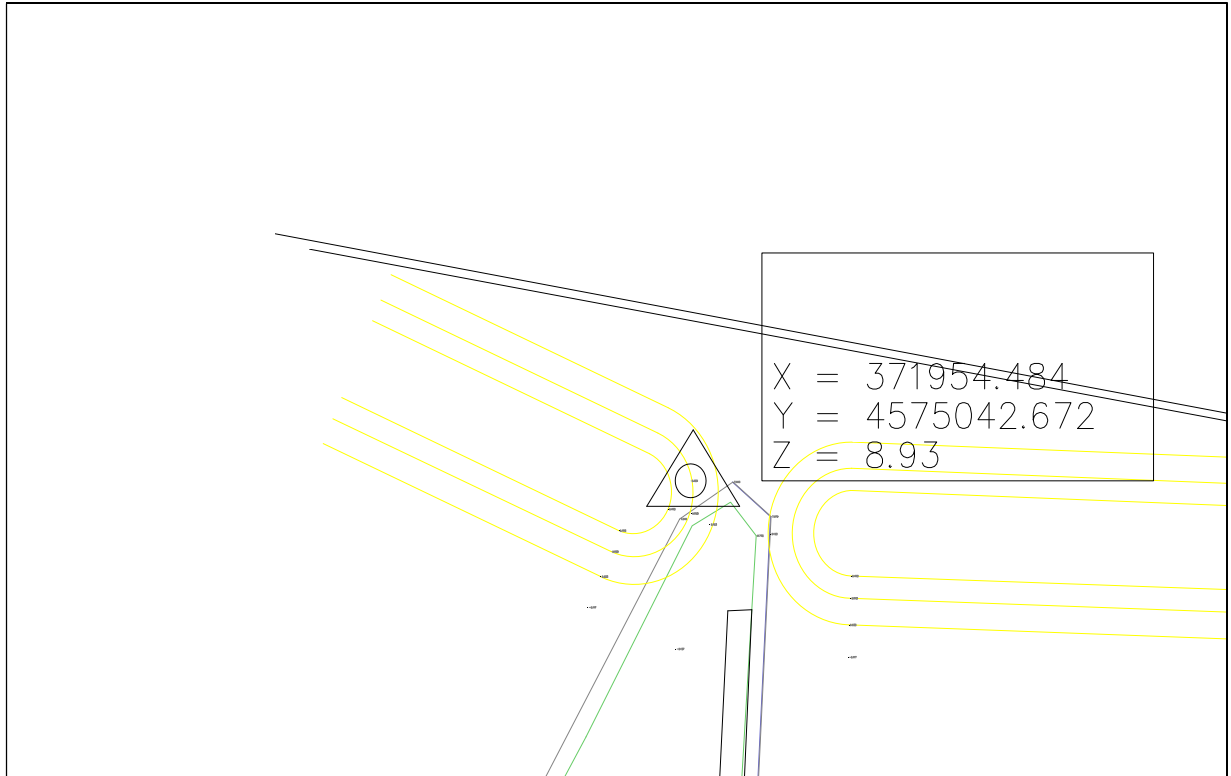

Figura 75- B 143

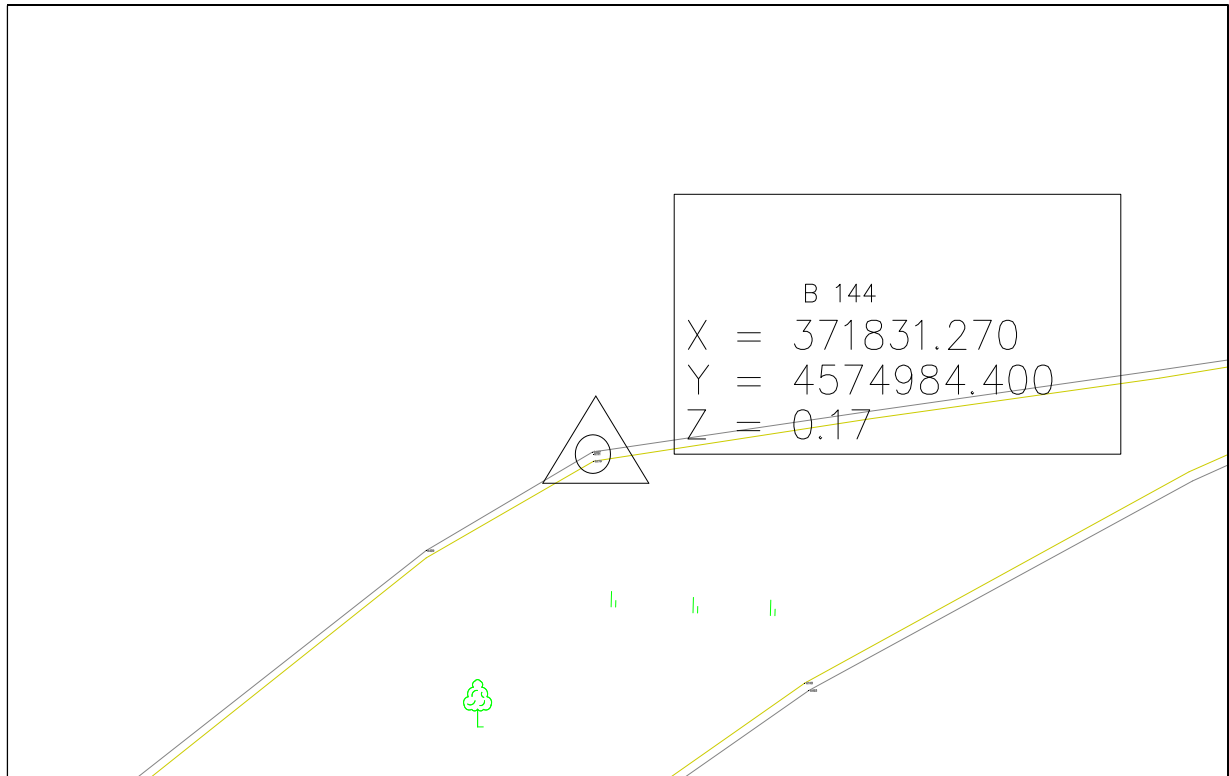

Figura 76- B 160

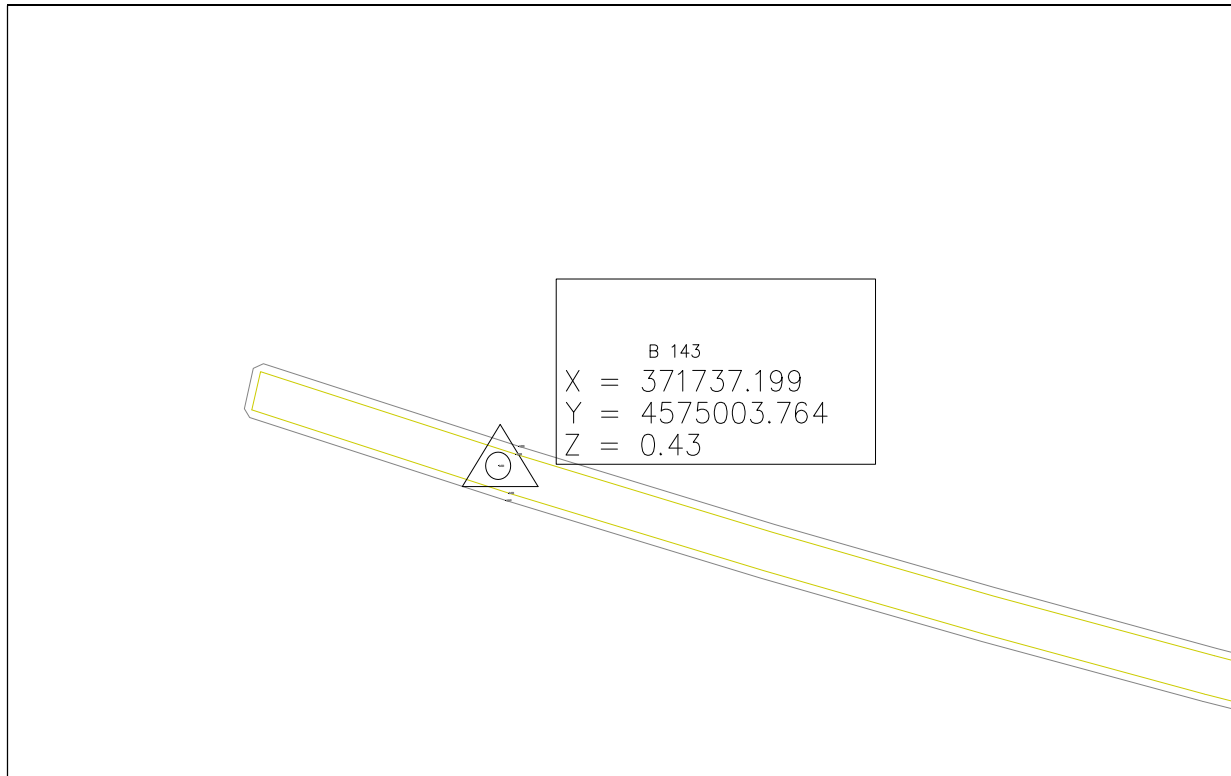

Figura 77- B 161

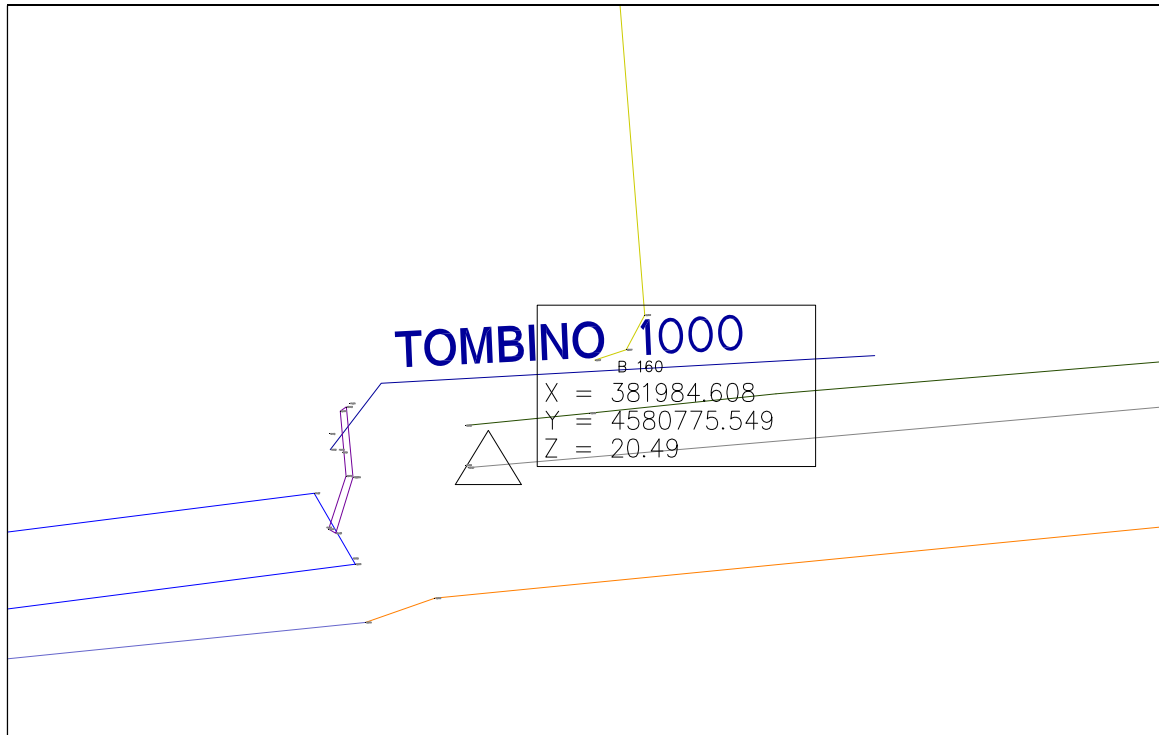

Figura 78- B 162

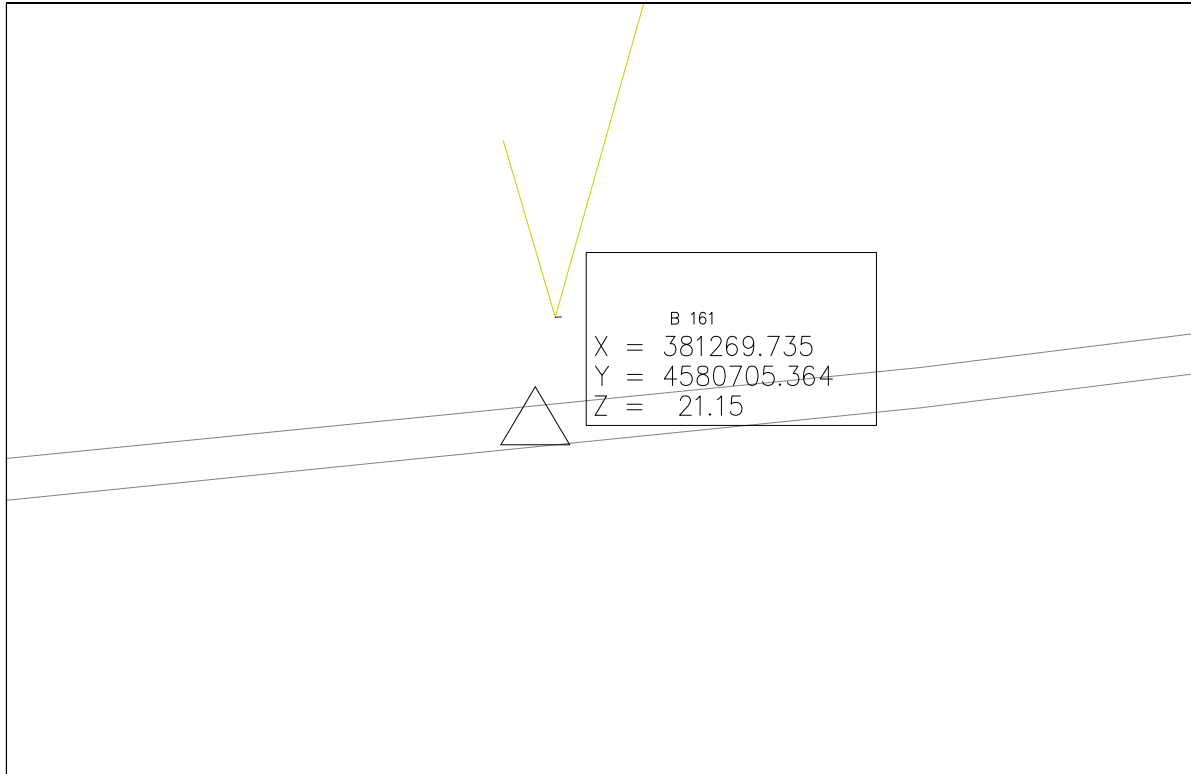

Figura 79- B 163

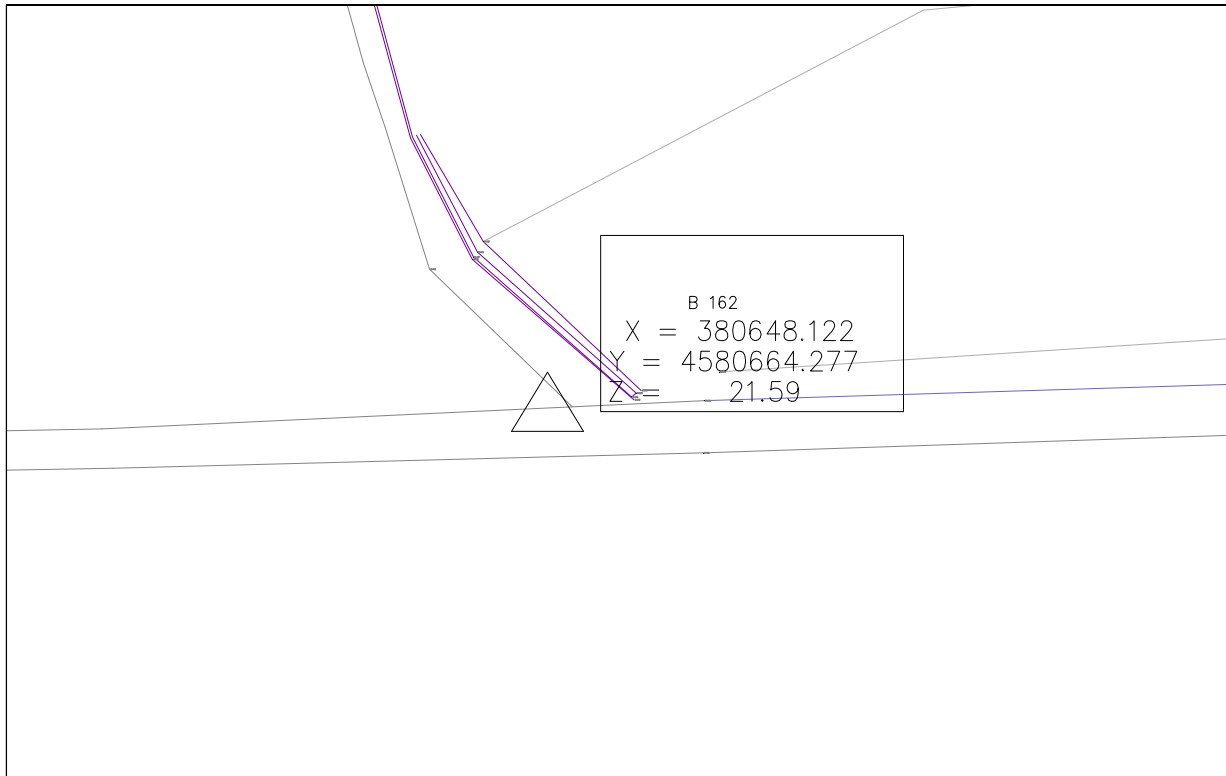

Figura 80- B 164

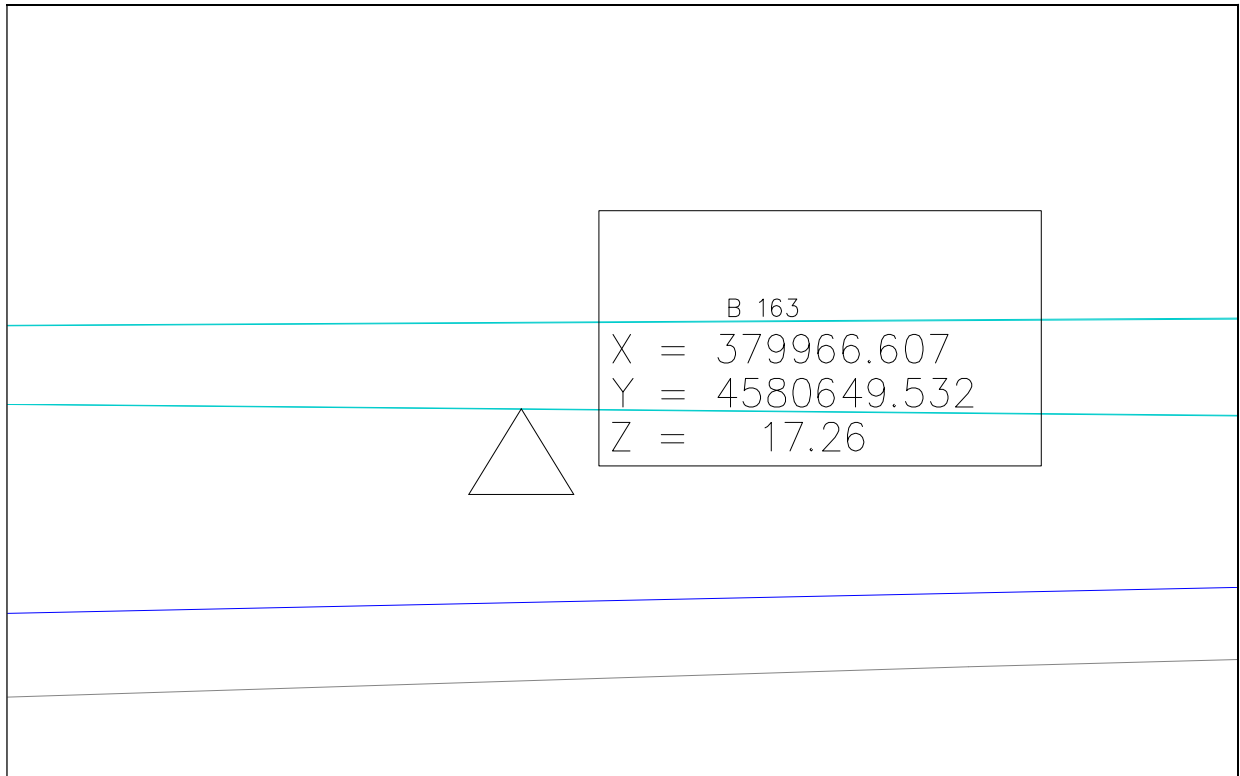

Figura 81- B 165

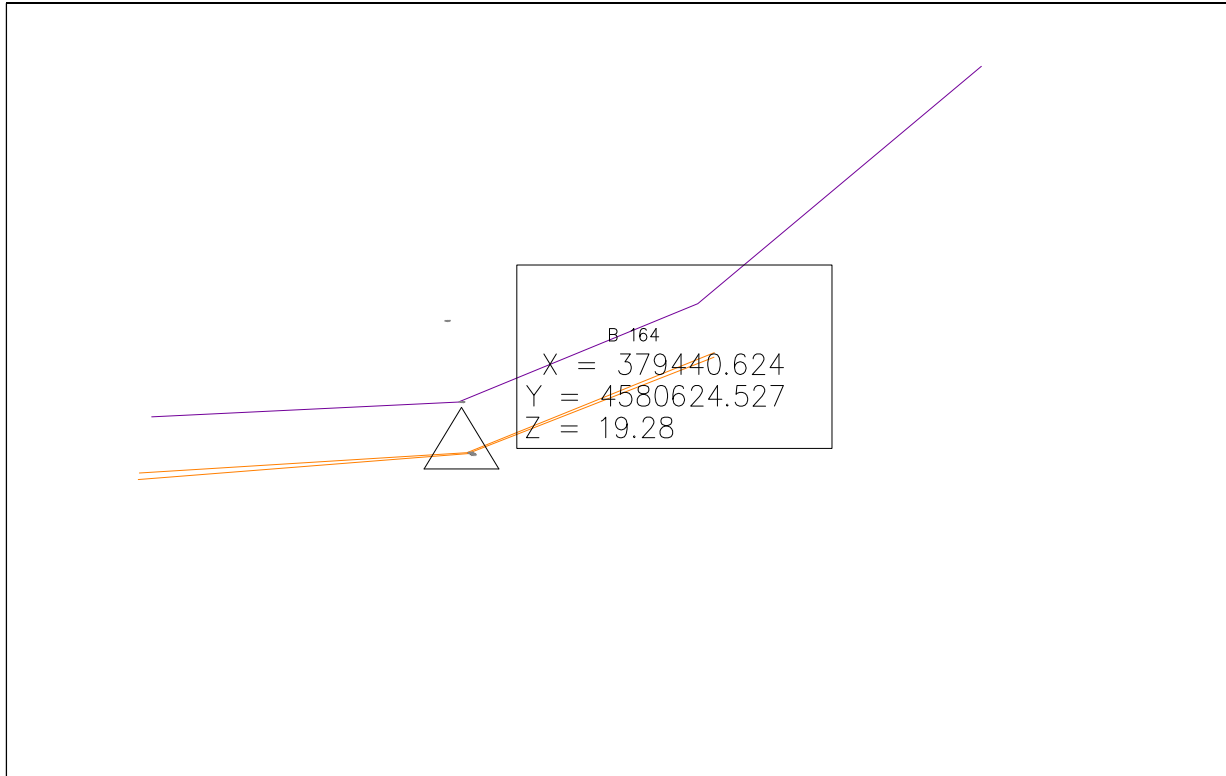
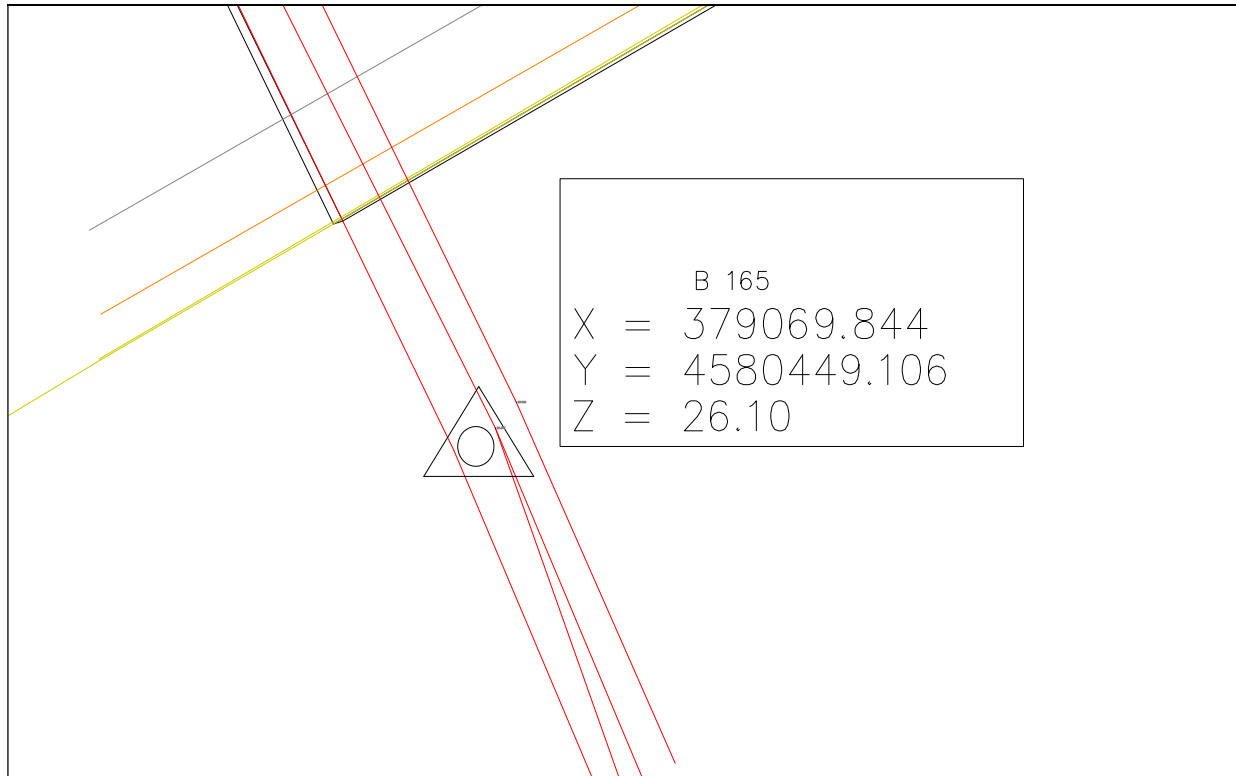
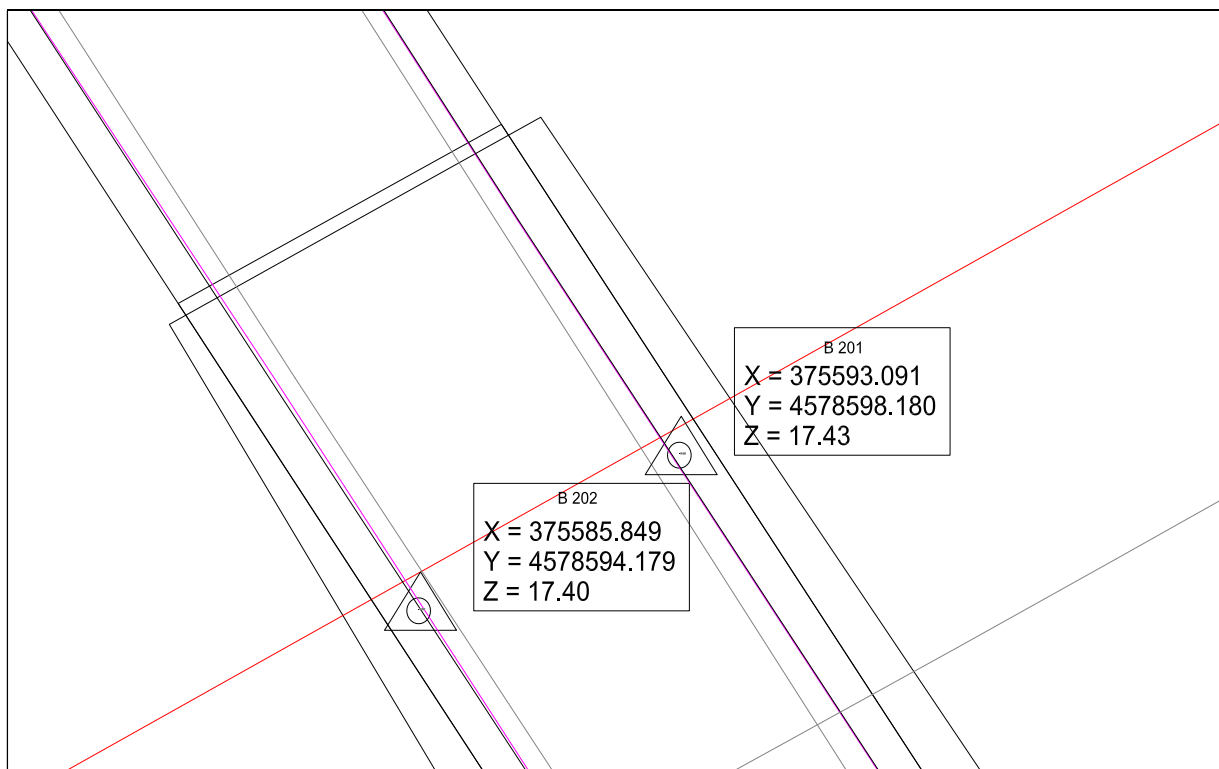

Figura 82- B 201, B 202