

RAPORT TEKNIK

Hartim Projekti : Nderhyrje emergjence ne Km 5+500 dhe Km 13+000, rehabilitimi i argjinaturave te "Perroit te Thate" ne segmentin "Dedaj – Bogë"

PROJEKT ZBATIMI

Contents

1. **TE PERGJITHESHME** 3
2. **VENDNDODHJA** 3
3. **PERSHKRIMI I GJENDJES EKZISTUESE.** 4
4. **KUSHTET GJEOLGJIKE** 8
5. **KUSHTET KLIMATIKE TE PELLGUT TE PERROIT TE THATE** 10
6. **KARAKTERISTIKA HIDROLOGJIKE TE PELLGUT TE PRROIT TE THATE** 12
7. **LLOGARITJE HIDROLOGJIKE PRROI I THATE** 17
8. **MASAT INXHINIERIKE** 22
9. **VOLUMET E PUNES QE JANE PARASHIKUAR** *Error! Bookmark not defined.*

1. TE PERGJITESHME

Hartimi i ketij projekti behet ne kuader te kontrates se mirembjatjes te rruges "Koplik - Boge" si pasoje e emergjences ne segmentin Dedaj – Boge. Ne kete segment rrugor si pasoje e reshjeve te ndodhura gjate sezonit te dimrit ka pasur permytje te rruges ne 2 segmente. Ne segmentin 1 (km 5+500) mungojne veprat e artit ndersa ne segmentin 2 (km 13+000) tombinot rrethore ekzistuese nuk e perballojne prurjen e perroit ne periudhat e reshjeve. Ne keto 2 segmente prurjet e perroit kaperderdhen mbi rruge dhe perbejne nje rrezik te madh per perdoruesit e rruges ku kane ndodhur edhe aksidente me pasoja te renda.

2. VENDNDODHJA

Segmenti Koplik-Boge nderpritet nga "Perroi i thate" I cili eshte dikues (afluent) i liqenit te Shkodres qe shtrihet ne anen perendimore te Alpeve Shqiptare. Perroi I Thate ka gjatesi 44.5 km dhe sipërfaqe te pellgut ujëmbledhës 233 km². Pjesa dërrmuese e këtij pellgu është e ndërtuar prej gëlqerorësh dhe dolomitësh të karstëzuar që formojnë luginën e "Perroit të thatë", mjaft karakteristike. Quhet "Perroi i thatë" sepse ka rrjedhje sipërfaqësore vetëm gjatë periudhës së plotave, ndërsa në pjesën më të madhe të vitit shtrati i tij është i thatë dhe ujërat shkarkohen në liqenin e Shkodrës kryesisht nëpërmjet rrugës nëntokësore.

Zona shtrihet ne koordinatat gjeografike:

Segmenti 1 - Km 05+500	$\varphi = 42^{\circ} 19' 01.80''N$
	$\lambda = 19^{\circ} 34' 53.91''E$

Segmenti 2 – Km 13+000	$\varphi = 42^{\circ} 21' 21.13''N$
	$\lambda = 19^{\circ} 37' 57.96''E$

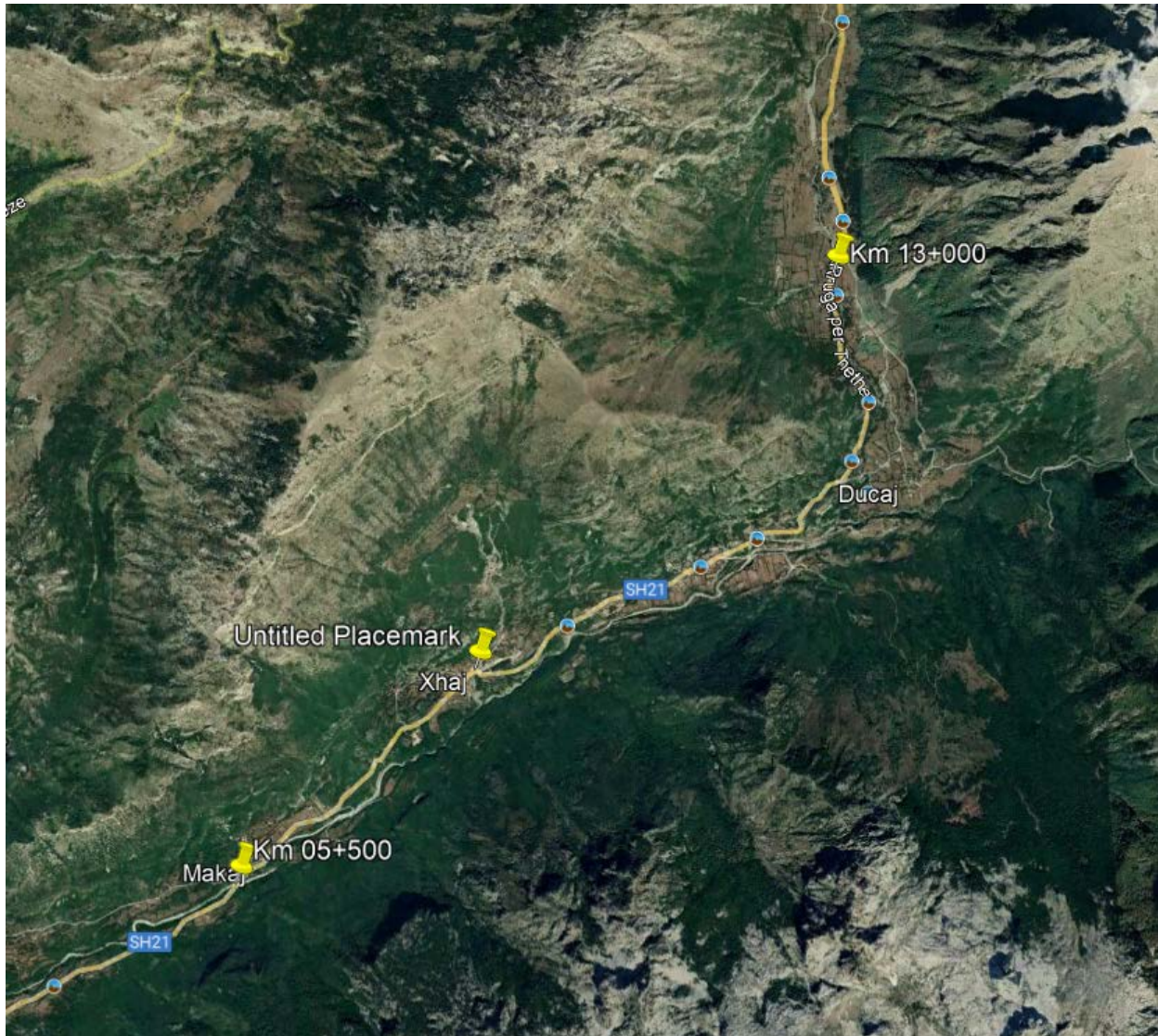

3. PERSHKRIMI I GJENDJES EKZISTUESE.

Segmenti rrugor Koplík-Dedaj është i asfaltuar dhe janë përmirësuar shtresat rrugore. Ky segment ndërpritet nga Perroi i Thate në këto 2 pika (km 5+500 dhe km 13+000) ku ka ndodhur demtimi i rruges. Rrjedha e perroi ka demtuar shtresat rrugore here pas here, aktualisht sipërfaqja e rruges është e betonuar në formë soletash.

Segmenti 1 Km 05+500 – Mungojne veprat e artit





Segmenti 2 – Km 13+000 – Tombino rrethore ekzistuese



4. KUSHTET GJEOLOGJIKE

1.1 Gjeomorfologjia.

Stratigrafia

Objekti i Perroit te Thate ben pjese ne zonen facialo tektonike te Alpeve Shqiptare. Ai ndertoht totalisht nga depozitime te Kuaternarit qe mbivendosen mbi formacionet karbonike mesozoike te pjeses veriore te Ultesires se Mbishkodres dhe pjeserisht te formacioneve argjilore te Neogenit te katit te Pjacsianit. Eshte pikerisht kjo mbivendosje e ketij formacioni filtrues mbi nje formacion karbonik me thyerje te shumta bllokore qe e bejne zonen te kete nivelin e ujrave shume thelle. Thyerjet bllokore jane prishje tektonike te vjetra dhe te reja te meshes Pliocenit dhe Kuaternarit me drejtim veriperendim-juglindje dhe verilindje- jugperendim. Keto thyerje e ndajne rajonin ne disa sektore apo zona fushore fushoro-kodrinoro me tendence ngritje ne anen lindore dhe ulje ne anen perndimore ne krah te liqenit te Shkodres. Nje nga keto fusha gjeomorfologjike eshte ajo e Koplik-Bajze ku ben pjese edhe projekti i proluvioneve te Pjetrosanit te formuarqysh rreth 120000 vjet me pare qe perkon me periudhen e fundit glaciale te Vurmit e deri ne ditet tona si rezultat i vershimeve te ketij perroi qe tashme jane te pakta vetem rreth 2 here ne vit. Kjo per shkak te ngritjes qe ka pesuar dhe peson kjo zone karbonike malore ne relacion me liqenin e Shkodres qe ulet. Perroi i Thate qe ka mundur te sjelle gjithë kete material zhavoror me trashesi qe arrin nga 8 - 10m deri ne 20m ne nje siperfaqe prej disa dhjetra km² te fushe Koplik-Bajze ka nje gjatesi ne plan si lugine prej 38km dhe me nje disnivel kuotash te lugines se tij nga 1300m ne Boge ne 81-94m ne objektin e Pjetrosanit dhe Sm ne grykederdhe ne liqenin e Shkodres. Keto prurje te ketij Perroi te rrembyeshem me origjine akullnajore, jane ndihmuar edhe nga perrenjte e tjere te Rrjollit dhe Kirit qe kane bere qe te spostoht liqeni i Shkodres nga lindja ne perendim dhe ne kete zone ne lindje te ketij liqeni te na formohen keto depozitime qe fuqishme zhavorore qe ne teresine e fushes se Mbishkodres ato kane trashesi qe arrijne edhe deri ne 80m.

Litologjia e Shtresave

Depozitimet e zones ku do kaloje traseja e rruges perfaqesohen:

Shtresa nr 1. Aluvione te perbera nga zhavore, copra guresh kryesisht gelqerore dhe surera. Jane pak te ngjeshura. **Karakteristikat fiziko-mekanike per kete shtrese jane:**

▪ Perberja granulometrike

Fraksioni argjilor	< 0.002 mm	2.5%
Fraksioni pluhuror	0.002-0.063 mm	5.5%
Fraksioni rere	0.063 – 2.0 mm	15.5 %
Fraksioni zhavor	2.0 - 60.0 - 100 mm	76.5 %

Lageshtia natyrale	$w_n = 2.5$	%
Pesha specifike	$\beta = 2.663$	gr/cm ³
Pesha volumore ne gjendje natyrale	$\Delta = 2.192$	gr/cm ³
Moduli i kompresionit	$E = 130$	kg/cm ²
Kendi i ferkimit te brendshem	$\varphi = 33$	°
Kohezioni	$c = 0.20$	kg/cm ²
Ngarkesa e lejuar ne shtypje	$\sigma = 1.80$	kg/cm ²

Shtresa nr 2, perfaqesohet nga gelqerore organogjeno - coprizore,.
Treguesit e vetive fiziko - mekanike te shkembinjëve karbonatik jane:

Pesha specifike	$\gamma = 2.67 \text{ g/cm}^3$
Masa volumore	$\Delta = 2.55 - 2.77 \text{ g/cm}^3$
Poroziteti	$\varepsilon = 0,5\%$
Moduli I deformacionit	$E_0 = 2.10^5 - 3.10^5 \text{ kg/cm}^2$
Kendi I ferkimit te brendshem	$\varphi = 37^\circ$
Rezistence ne shtypje nje boshtore	$R_c = 8000 \text{ kg/cm}^2$
Ngarkesa e lejuar	$\sigma = 6 \text{ kg/cm}^2$

Perfundime

- * Ne zonen e studjuar marin pjese depozitimet e moshave nga te Cretaku e deri ne Kuarternar (depozitimet eluvion-deluvionet).
- * Ketu kemi te bejme kryesisht me depozitimet karbonatike (gelqerore), kongl;brekcie (formimet shtresore te brekcieve e zajeve te cimentuara) dhe depozitimet dherash qe jane aluvion deluvionet, proluvionet.
- * Depozitimet karbonatike (gelqeroret) kane karakteristika shume te mira fiziko-mekanike per mbeshtetje strukturash te ures. Ato mund te kene problem vetem nga rezimet e gureve apo te ndonje blloku te lire, nga erozioni, ndaj ato duhet te pastrohen mire.
- * Kushtet gjeologjike te trasese se rruges ne depozitimet konglomeratike klasifikohen sipas GSI: Klasa III ne depozitimet konglomerate dhe klasa II ne depozitime gelqerore.
- * Depozitimet konglobrekcieve (formacione shkembore te cimentuara forte) edhe pse kane nderfutje linzash argjilitesh dhe alevrolitesh ndermjet tyre jane shume te qendrushem ne skarpata. Ato ne pergjithesi duhet te llogariten ne raportet 3/1 ne skarpate.
- * Proi i Thate eshte me pjeresi te madhe dhe gjatesi te shkurter pra ka energji te madhe. Edhe prurjet shkembore jane te madhesive te konsiderushme, dhe te parrumbullakuara.
- * Ne keto kushte rekomandojme qe shtrati i prroit kerkon sistemim e ngritje argjinaturash e shkallezime te shtratit per te ulur energjine e lumit.
- * Mendoj se themelet e ures dhe boksit duhet të vendosen në shkëmbin rrenjesor për të mbrojtur uren dhe boksit në rast te prurjeve masive dhe te përmbytjeje lumore. Ky prrua per vet faktin qe ka energji te konsiderushme ne rast plotash, krijon kushte per shkaterrim te veprave te artit.
Ne keto kushte shtrati i prroit kerkon sistemim e ngritje argjinaturash e shkallezime te shtratit per te ulur energjine e lumit si ne segmentin Ch 5 + 500 boxi, ashtu dhe ne Ch 13 + 000 ura .

5. KUSHTET KLIMATIKE TE PELLGUT TE PERROIT TE THATE

Zona ku shtrihet pellgu i Prroit te Thate bazuar ne ndarjen klimaterike te vendit tone i perket zones klimatike mesdhetare veriore. Temperatura mesatare vjetore lekundet nga rreth 12o C ne Lekbibaj. Ndersa temperatura minimale te regjistruara ne Lekbibaj arrijne deri ne rreth -21o C. Periudha me temperatura negative ne zone zgjat deri 73 dite ne vit ndersa me temperatura me te vogla se -5o C zgjat deri ne 14 dite ne vit. Temperaturat maksimale te regjistruara ne Lekbibaj arrijne deri ne 39.5°C. Nga pikpamja e sasise se reshjeve qe bien ne zone futet ne zonat me me shume reshje ne Shqiperi. Sasia mesatare e reshjeve qe bien ne zone lekunden ne rreth 2190 mm ne Lekbibaj.

Per natyren e projektit ne shqyrtim rendesi kane reshjet maksimale per zgjatje te ndryshme dhe intensiteti i tyre. Reshjet maksimale 24 oreshe ne Lekbibaj jane rreth 199 mm. Intensiteti maksimal i regjistruar per stacionin Lekbibaj ka qene 49 mm per 10 minuta. Zona e projektit karakterizohet nga intensitete te larta dhe zgjatje te konsiderueshme te ketyre intensiteteve ne kohe. Reshjet me te medha vjetore te regjistruara ne stacionin e stacionin Lekbibaj ne vitin 1979 ne me 2800 mm.

RESHJET MUJORE DHE VJETORE TE ZONES SE PROJEKTIT

Reshjet mesatare mujore per dy stacionet e marre ne konsiderate jepen ne tabelen me poshte

Vendmatja	MUAJT E VITIT												MESATARE VJETORE (MM)
	1	2	3	4	5	6	7	8	9	10	11	12	
Fierze (mm)	259	254	184	175	135	78	57	91	159	238	316	332	2280
Lekbibaj (mm)	226	207	176	170	148	82	27	96	114	323	299	322	2190

Ne forme grafike reshjet mesatare te dy stacionet jepet ne grafik e meposhtem

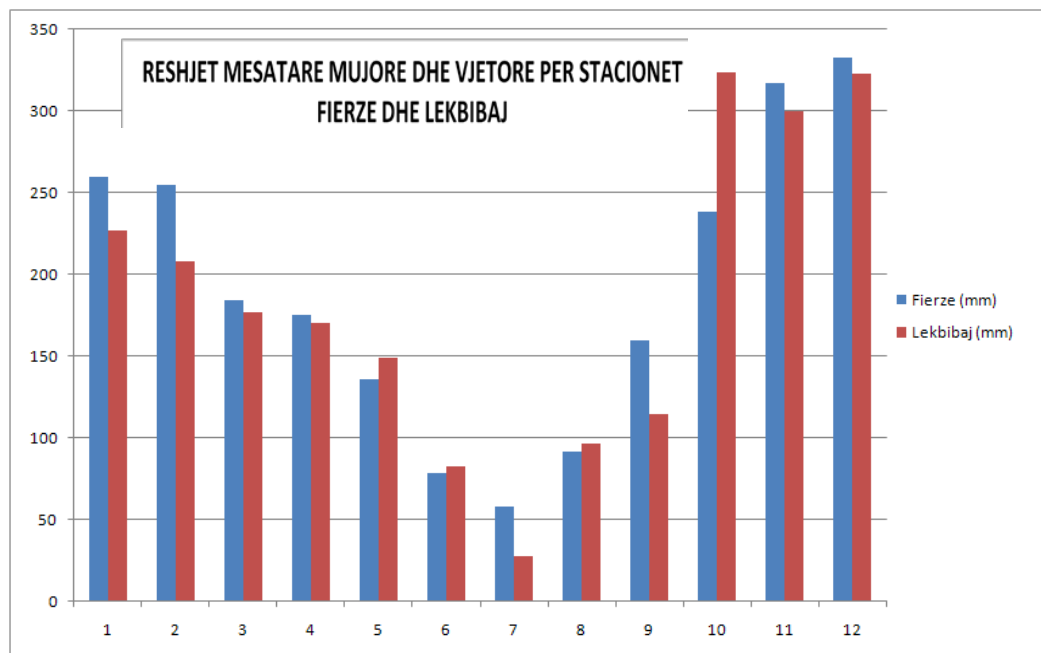

Reshjet mesatare dhe vjetore ne dy stacionet e Fierzes dhe Lekbibajt

Vlerat e reshjeve 24 oreshe per dy stacionet jepen ne tabelen e meposhteme

Vendmatja	MUAJT E VITIT												VLERAT MUJORE MAKSIMALE
	1	2	3	4	5	6	7	8	9	10	11	12	
Fierze (mm)	161	140	125	144	81	101	98	169	279	138	231	155	279
Lekbibaj (mm)	125	107	140	178	63	90	135	132	160	199	192	135	199

Reshjet maksimale 24 oreshe per stacionet e Fierzes dhe Lekbibaj

Ndersa vlerat e intensiteteve te reshjeve me periudhe zgjatjeje nga 10 minuta ne 24 ore per stacionin e Lekbibaj jepen ne tabelen e meposhtme

Periudhe e zgjatjes se reshjeve	Perseritje ne perqindje				
	1	2	5	10	20
10 minuta	49	44	39	34	29
20 minuta	61	55	49	43	37
30 minuta	69	62	55	48	41
1 ore	86	77	68	60	52
2 ore	106	95	85	74	64
3 ore	120	108	96	84	72
6 ore	149	134	119	104	89
12 ore	184	165	147	129	110
24 ore	229	206	183	160	137

Intensitetet e reshjeve maksimaleme zgjatje nga 10minuta ne 24 ore per stacionin e Lekbibaj

ZGJATJANE KOHE E SHIUT (MINUTA) Bazuar ne tabelen e mesiperme ndertojme kurbat e varesise se sasise se reshjeve nga koha e zgjatjes se tyre ne grafikun

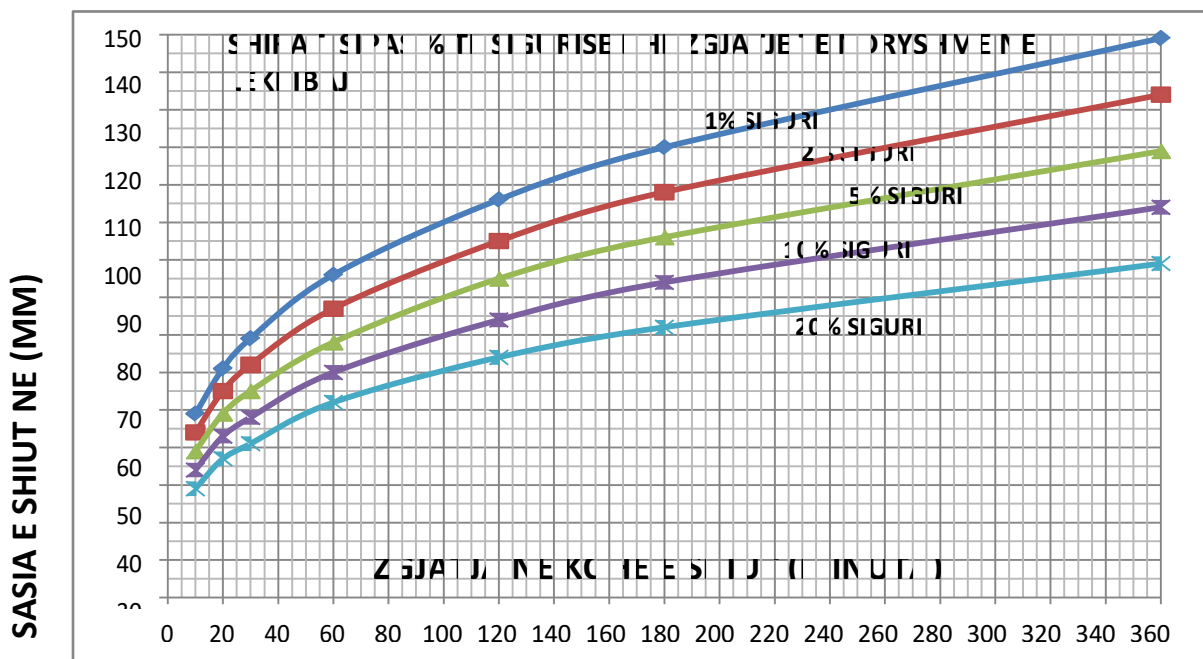

Grafiket e varesise se sasise se reshjeve per zgjatje te kohes dhe siguri te ndryshme ne Lekbibaj

RESHJET NE FORME BORE NE ZONEN E PROJEKTIT

Bora eshte fenomen i zakonshem ne zonen e projektit por ajo nuk qendron per nje kohe te gjate ne pellgun ujembledhes. Megjithate ajo mund te krijoje shtrese dhe te qendroje me gjate ne dimra te jashtezakonshem me temperatura negative. Te tille ne histori kane qene dimrat e viteve 1937, 1944-45, 1954-55, 1962-63 dhe viti 1985.

6. KARAKTERISTIKA HIDROLOGJIKE TE PELLGUT TE PRROIT TE THATE

Faktoret baze qe percaktojne karakteristikat hidrologjike te zones se projektit jane klima, topografia dhe gjeomorfologjia e saj.

Siperfaqja e pellgut ujembledhes eshte rreth 110km². Gjatesia ujerrjedhese e pellgut eshte rreth 6.9 km dhe pjerresia mesatare e shtratit te deges kryesore eshte rreth 21% e cila eshte me e theksuar ne pjeset e larta te pellgut dhe me e bute ne rrjedhjen e poshtme te pellgut. Pellgu ujembledhes jepet me posh. Rrjeti hidrografik i pellgut te Prroit te Thate karakterizohet nga dege me pjerresi te medha kryesisht ne pjesen e sipërme te tij por edhe ne anen e poshtme te pellgut. Megjithate duhet theksuar se ne rrjedhjen e poshtme pjerressia e shtratit ka ndryshuar ne menyre te konsiderueshme si rezultat i grumbillimit te prurjeve te ngurta.

Plotat maksimale ne pellgun e Prroit te Thate formohen si rezultat i shirave te dendur me intensitet te larte dhe te vazhdueshem. Ne pjesen dermuese ato krijohen ne periudhen e vone te vjeshtes dhe gjate dimrit. Per qellimin e projektit tone llogaritjet hidrologjike jane bere vetem per prurjet maksimale duke llogaritur plotat per zgjatje te ndryshme te shirave si dhe periudhe perseritje te ndryshme.

Per llogaritjet hidrologjike jane shfrytezuat te dhenat e dy stacioneve te Fierzes dhe Lekbibajt. Rrjeti hidrografik i pellgut te Prroit te Thate karakterizohet nga dege me pjerresi te medha kryesisht ne pjesen e sipërme te tij por edhe ne anen e poshtme te pellgut.

Pellgu ujembledhes I Prroit te Thate

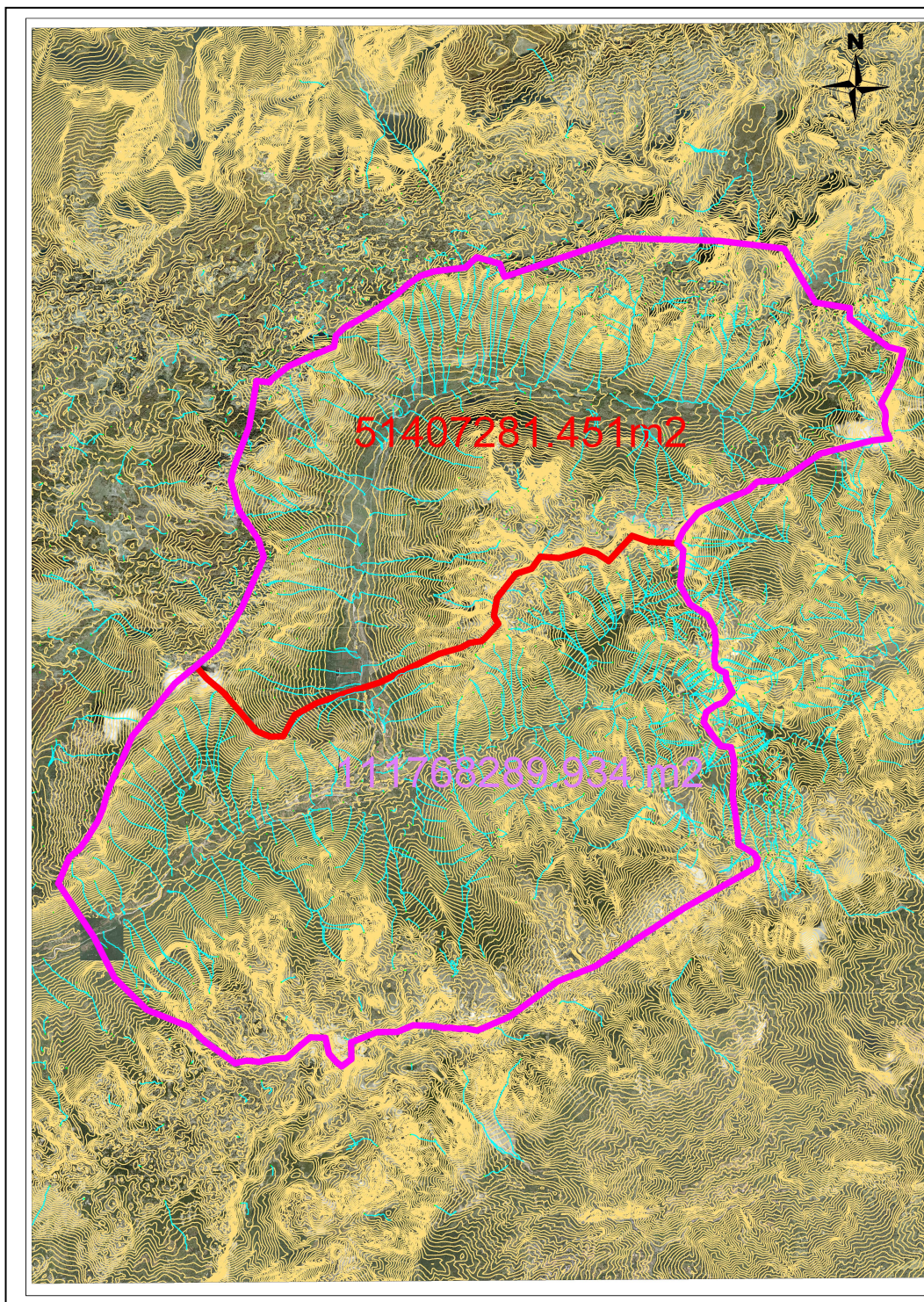

GJEOMORFOLOGJIA

Gjeomorfologjia e lugines se Perroit te Thate shtrihet midis dy vargjeve malor: atij te Rabe-Biga e Gimajt-Kunora e Lohes ne lindje dhe vargut Radohime-Velecik ne perendim.

Perroi i Thate ndertohet nga disa dege ku me krysoret jane:

- Perroi igrykes se lugjeve
- Perroi Shenti imadh
- Perroi i Shpendve

Dy deget e para bashkohen ne Oucaj, kurse dega e Perroit te Shpendve bashkohet me Perroin e Thate ne afersi te fshatit Bzhete.

Perroi i Grykes se Lugjeve

Fillon si lugine ne anen perendimore te Qafes se Terthores dhe e ka zanafillen nga burimet e Qafes se Shtegut te Dhenve me kuote 2104m. Nga Maja e Vuklit e Gropa e Radohimes me kuote 2445m.

Perroi Shenti i Madh

E ka zanafillen nga Bjeshket e Namuna me malet kryesore si Maja e Madhe me kuote 2013m. Stanet e Dedajve dhe Maja e Ducajve me kuote 2221m.

Perroi i Shpendve.

E ka zanafillen nga Razma, Vrithi e Troshani.

Vete lugina e Perroit te Thate nga Boga deri ne fshatin malor te Ducajve formon nje hark ne drejtim te juglindjes, ndersa pas bashkimit me dy deget e tjera merr drejtim jugperendimor dhe poshte fshatit Koplík,

Siperm-Pjetroshan merr drejtim lindje-perendim deri ne derdhje ne liqenin e Shkodres ne pjesen verilindore te ketij liqeni.

Duke u ndertuar nga shkembenj gelqerore te karstezuar te cilet formojne nje strukture antiklinale, ajo ka nje coptim te vogel horizontal nga 0.1 deri ne 1km per kilometer dhe nje coptim vertikal shume te madh qe arrin ne 300-500m. per km².

Vete struktura antiklinale karbonatike dhe lugina ne forme govate formon nje inversion reliefi si pasoje e nje thyerje te fuqishme tektonike qe e copton strukturen nga fshati Troshan ne fshatin Dedaj. Faktoret e ketij ndertimi gjeologo-tektonik kane bere qe lugina ne aspektin morfologjik te ndahet ne disa sektore :

Sektori i siperm i lugines qe njihet me emrin e Boges(nga Okoli i Boges deri ne fshatin Ducaj), apo Perroi i Grykes se Lugjeve sic pershkruam me siper ka forme gjysem harku me shpate pothuajse simetrike ne te dy anet e lugines. Kjo lugine ka care masen e shkembenjve karbonatike te karstezuar ne nje thellesi prej afro 1300m. Vete lugina ne kete sektor ka formen e nje korite, gje qe deshmon se ka origjine akullnajore. Mendohet se mosha e saj eshte Vurmiane, rreth 120 mije vjet me pare, e perpunuar nga nje gjuhe akullnajore shume e madhe qe ka zbritur ndoshta nga Radohima. Kjo origjine akullnajore deshmohet nga pragjet e

shumta, por sidomos nga depozitimet morenore(akullnajore) te shumta qe jane grumbulluar me poshte kesaj lugine me moshe ndoshta te Pleistocenit te poshetm. Nisur nga disniveleli i madh i kesaj lugine fillimisht ne Boge dhe deri ne sektorin e mesem ne Ducaj i japin ketij sektori te siperperm pamjen e nje lugine qe quhet nga fjeografet te "Varur" akullnajore.

Sektori i mesem i lugines qe e fillon jeten e saj ne fshatin Ducaj, pas bashkimit me degen e Perroit Shenti i Madh nderton si morfologjine e saj ashtu edhe drejtimin per ne veriperendim. Ajo tashme eshte nje lugine me profil terthor asimetric, e tipit tektoniko- eroziv per shkak te thyerjes se fuqishme Troshan-Dedaj.

Si rezultat i renies monoklinale te shtresave karbonatike me perberje gelqerore te dolomitizuar ajo vazhdon ne drejtim te jugperendimit me nje asimetri me te dukshme te shpateve te lugines.

Shpati veriperendi moreshte me i bute, ndersaj juglindori ka shpate mjaft te pjerrtet e te thepisur nga 900 deri 1000m.

Fundi i lugines se Boges qe ndodhet midis dy tshatrave Bzhete dhe Dedaj thellohet deri ne 4-5m.dhe merr tiparet te grykes dhe te nje kanioni te rrethuar nga shkembenj kompakt karbonatik qe nuk lejojne erozion te madh por vetem levizje te materialit qe rreshqet e grumbullohet nga shpatet e pjerrta te maleve te thepisur po me ndertim karbonatik e shume me pak silicor.

Poshte tshatit Dedaj dhe deri ne tshatin Zagore lugina thellohet e ngushtohet edhe me teper edhe merr tiparet e nje kanioni te vertete qe njhet nga gjeogratet me emrin Kanioni i Perroit te Thate.

Ndermjet tshatrave Zagore dhe Poic kanioni ngushtohet shume nga poshte dhe mbyllet plotesisht ne pjesen e siperme.

Poshte tshatit Gradec kjo lugine e le zonen e Alpeve Shqiptare dhe tutet ne zonen e tushes se Mbishkodres qe perfshihet ne Ultesiren e Shkodres si pjese e Ultesires Bregdetare .

Ne kete zone tushore me tipare kodrinore, lugina eshte e ngushte dhe e ceket, pa rrjedhje te dukshme ujore gjate vitit. Rrjedhja ujore e dukshme dhe shume e vrullshme si dhe prurjet e materialit zhavoror jane ne kohe rrebeshesh te rreshjeve te vazhdueshme si rezultat i ngritjes edhe te nivelit te ujrave te gjithe zones karbonatike tushe dhe perberje zhavorore.

Sektori i siperperm

Dallohet per rreshje te medha debore qe qendrojne gjate, ndersa i mesmi dhe i poshtmi rreshjet e debore jane te pakta por me rreshje shiu te shumta qe arrijne deri ne 3039mm. Ne vit. Mbulesa bimore e shpateve te lugines ka karakter shkurresh dhe eshte e degraduar.

Per shkak te ndertimit te saj gjeologo-tektonik me nje strukture antiklinale ujerrjedhja e saj siperfaqesore eshte e paket per shkak se burimet ujembledhese rrjedhin vetem ne zona te caktuara te saj per shkak te filtrimit ne nivelet me te poshtme ne krahet ansor te antiklinalit. Prurja e ujit dhe rrjedhimisht edhe e materialeve te ngurte transportohet ne raste te vecanta gjate vitit rreth 2 here ne vit.

KUSHTET GJEOLGOGO-INXHINJERIKE

Kushtet gjeologjiko-inxhinjerieke jane pak a shume uniforme ne te gjithe pjeset e sektorit, por qe duan vemendje dhe ndjekje gjate procesit te shtrytezimit nga specialiste te fushes.

Bazuar ne ndertimin gjeologjik te sektorit te studjuar verejme se kemi nje ndertim litologjik me sedimente copezore zhavorore e shume pak ranore, te thata, me cimetim karbonatik te dobet, pra

ne pergjithsi te shkrifeta, rrjedhimisht perfshihen ne formacione gjeologo-inxhinjrike relativisht te buta, pra me rezistence te dobet ne qendrueshmerine e tyre ne shtypje nje boshtore e ne drejtime te tjera.

Duke qene se keto formacione jane te dobta duhet qe kendi i skarpates te merret i vogel dhe rekomandojme qe ne projektin e shfrytezimit dhe ate hidroteknik te parashikohen masa mbrojtese, duke projektuar shkalle te rregullta.

Duhet theksuar se ne disa pjese te sektorit sidomos ne pjesen lindore dhe qendrore ku jane bere germime me thellesi te madhe duhet qe shfrytezimi te drejtohet duke formuar shkalle jo me te medha se 4m dhe duke rregulluar kendet e skarpates per cdo shkalle qe do krijohet.

HIDROGJEOLGJIA

Per vete ndertimin gjeologo-tekonik dhe litologo-formacional , hidrogjeologjia e zones eshte komplekse, pa probleme te medha per shfrytezimin ne teresine vjetore si ne dimer dhe ne vere. Por, ne momente te rrebesheve te fuqishem si rezultat i grumbullimit te madhe te ujit ne shkembenjte karbonatike te lugines se ketij perroi, gjeomorfologjine e se ciles e pershkruam gjeresisht ne kapitullin e posacem per te, kemi vershime rreth dy here ne vit te vete ketij perroi. Kjo e ndihmuar edhe nga shkrirja e debores dhe rritja e nivelit te ujit ne shkembenjte karbonatike qe jane ne vetvete rezervuare ujembajtese.

Pjesa e sipërme e lugines dhe bazamenti i saj eshte i perbere nga shkembenj karbonatike te mesozoikut qe jane poroz, me carje dhe karstezim te zhvilluar.

Kompleksi formacional qe mbizoteron ne kete objekt eshte ai copezor me perberje zhavore e me pak zhure e rere me koeficient te larte filtrimi. Ato i perkasin depozitimeve te Holocenit te poshtem qe jane formimet taracore dhe te Kuaternarit te vonshem deri ne ditet tona qe jane depozitimet e shtratit te Perroit te thate qe akumulon material ne kohe rreshjesh te rrembyeshme, rreth dy here ne vit. Keto formacione te shtratit jane akoma me te pershkueshme se depozitimet taracore per faktin qe jane me te shkrifta se ato taracoret qe jane disi me nje cimentim te dobet karbonatik.

Nga pusët e studimet e kryera ne kete zone trashesia e ketyre depozitimeve luhetet nga 10 deri ne 20m. trashesi.

Me kerkesen e z. Paulin DODA ne vitin 2004 eshte kryer shpimi 1/2004 konform projektit te bere nga Inxh. Hidrogjeolog Tonin Vjerdha.

Nisur nga te dhenat e peraferta te nxjerra nga harta topografike shkalle 1:10000, shpimi ne fjale rezulton te kete keto kordinata:

$$X = 4679330$$

$$Y = 4370450$$

$$Z = 91.50m$$

Thellesia e tij eshte 210m duke pershkuar: Nga 0.00 deri 50.00 zhavore

Nga 50.00 deri 160.00 Argjila e zhavore

Nga 160.00 deri 210.00 Konglomerate brekcie ujembajtese.

Shpimi eshte kryer me balle te plote, ndaj te dhenat jane nxjerre ne menyre analitike duke marre per baze edhe shllamin qe ka dale gjate avancimit.

Diametri i shpimit eshte 500mm.

Niveli statik i matur rezulton te jete $NS = 73m$.

Prurjet e tij janë $0=501/\text{sek}$ nga ku për nevoja larje të materialit inert janë të mjaftueshme vetëm $2001/\text{min}$.

Megjense qëllimi i shpimit është nxjerrja e ujit vetëm për larje inertesh, nuk është parë e nevojshme që të bëhen analiza kimike për ujin.

Neqoftese në të ardhmen lind nevoja për një gjë të tilla, çdo gjë mbetet e hapur konform ligjeve të K.K.U.

Megjithkëtë, duke u nisur në aspektin e përgjithshëm, ujrat e kësaj zone janë të tipit hidrokarbonat kalciumi ($\text{H}_2\text{CO}_3\text{-Ca}$), ku predominon joni HCO_3 me një vlerë mesatare prej 365.8mg/l dhe për $\text{Ca}=117.5\text{mg/l}$.

Fortesia e përgjithshme lëviz nga 12.77 gradë gjermane deri 23.74 gradë gjermane.

Mineralizimi i përgjithshëm luhet 408.39 mg/l deri 880.04 mg/l , kurse pH varion $7-8.5$, çka tregon për një ujë normal.

Brenda zonës që mendohet të shfrytëzohet aktualisht nuk ka objekte ujembledhese ose ujëmarrese apo shpime hidrogeologjike. Ato janë shumë larg zonës që do të shfrytëzohet, megjithatë janë marre e do të merren masa mbrojtëse edhe pse janë larg zonës së shfrytëzimit, ashtu siç do të merren masa mbrojtëse edhe për vërshimet qoftë edhe të rralla të këtij përroit.

7. LLOGARITJE HIDROLOGJIKE PËRROI I THATË

BOGË KOPLIK

Llogaritjet hidrologjike janë bërë për dy akse. Njeri në $\text{Km}5+500$ dhe kuote mbi nivelin e detit 550 m . Aksi tjetër në $\text{Km}13+000$ dhe kuote 811 m m.n.d.

Të dhënat e llogaritjeve hidrologjike rezultojnë:

- Në $\text{Km}5+500$ $Q_{\text{max}}=786\text{ M}^3/\text{sek}$
- Në $\text{Km}13+000$ $Q_{\text{max}}=423\text{ M}^3/\text{sek}$

Keto plota maksimale janë llogaritur për frekuencë 2% ose perseritje njëhere në 50 vjet.

Llogaritja është bërë mbi dy metoda llogaritëse.

- Manuali I projektimit hidraulik USA. Formula Bransby-Williams, me anë të së cilës përsore janë elementet hidrologjik dhe hidraulik. Lartësia mbi nivelin e detit influencën në mënyrë të terthortë.
- Formula Giandoti. E cila merr në konsideratë të drejtpërdrejta lartësinë mbi nivelin e detit krahas elementeve të tjera hidrologjike dhe hidraulike. Kjo formulë jep të dhëna të krenaqshme për lartësi mbi 500 M mbi nivelin e detit

Nisur nga seksioni hidraulik I për llogaritje, rezulton se uji në dy akset ngrihet afërsisht 1.9 M mbi nivelin e rrugës eksistuese. Prandaj është e rëndësishme përzgjedhja e seksionit të përcjelljes së ujit.

Niveletat e kalimit janë parashikuar që të ngrihen 3.1M në intersektimin 5+500 dhe 3.8 M në intersektimin 13+000.

Keto ngritje të nivelit të tabanit të rrugës e zgjidhin perfundimisht permbytjet e ndodhura në keto dy akse.

Energjia e levizjes për njësi të masës është $V^2/2g$

Në Km5+500 energjia e njesise se mases është : 6.74 N*M . Po kaq afersisht është edhe energjia e levizjes për njësi të masës në Km13+000.

Llogaritjet hidrologjike kanë parashikuar që keto plot atë përcillen plotësisht nga seksioni I gjalle.

Pra të mos kemi prerje të plotës. Prerja e plotës ndodh kur kemi frekuencë perseritje 1% e lartë. Në rastin tonë kemi punuar me frekuencë perseritje 2%.

Te dhënat:

- Disertacion doktorature Tanja Porja. Reshjet maksimale 24 orëshe 2% siguri 300 mm/orë
- Harta e reshjeve në Shqipëri. Zona 2500 deri 3000 mm në vit
- Klima e Shqipërisë. Akademia e shkencave të RPS të Shqipërisë. Instituti Hidrometeorologjik faqe 213. Rrethi Shkoder reshjet vjetore 1797 mm/vit
- VKM 628 dt.15/7/2015 "Për miratimin e rregullave teknike të projektimit dhe ndërtimit të rrugëve". Libri 4. Kullimi Faqe 90.
- Manuali I projektimit hidraulik USA

$$Q=0.00278 C * C_f * I * A$$

Q prurja në m³/sek

Në librin 4 përcaktohet për $i > 6\%$ dhe kategorinë D sjell $C=0.38$

$C_f=1.2$ për siguri 2% njëherë në 50 vjet.

I intensiteti I reshjeve në mm/orë

A sipërfaqja e kullimit në ha.

- Koha e përqendrimit T_c :

1. Formula Giandoti. $T_c = (4 * A^{1/2} + 1.5 * L) / 0.8 * Z^{1/2}$

T_c koha e përqendrimit

A sipërfaqja në Km²

L distanca në Km

Z kuota në m

2. Formula Bransby-Williams (te dhenat e stacionit Lekbibaj)

$$T_c = 21.3 * L / A^{0.1} * S^{0.2}$$

L gjatesia ne km

S siperfaqja ne km²

S pjerresia

LLOGARITJE HIDROLOGJIKE

1. Llogaritja e prurjes se ujit ne intersektimin e rruges me Prroin e Thate. Siper.

$$Q = 0.00278 C * C_f * I * A$$

Q prurja ne M³/Sek

A siperfaqja e pellgut shimbledhes . A=51.4 km².

C koficent qe merr ne konsiderate kthimin e reshjeve. Referenca " Manual I Projektimit Hidraulik USA". Libri I 4 Kullimi. Referuar ketyre dy referencave dhe elementeve hidraulik dhe gjeomorfologjik rezulton C=0.52

C_f. faktori I frekuences. Referenca " Manuali I projektimit Hidraulik USA". Koficenti Rajti – Meklaflin. Per Frekuence 2%. C_f=1.2

I intensiteti i reshjeve ne mm/ore. Llogaritja e I varet nga dy faktore . sasia e reshjeve maksimale per T_c. Llogaritja e T_c

Per llogaritjene reshejeve maksimale jane marred y burime te dhenash.

A. Kurbat IDF Razem. Libri I katert Kullimi

B. Te dhenat e stacionit hidrometeorologjik ne Lekbibaj. Keto te dhena plotesojne kerkesat e Organizates Boterore te Meteorologjise ne Paris.

Llogaritja e T_c. Kjo llogaritje eshte bere bazaur ne dy metoda. Per arsye qe te I afrohem sa me shume realitetit.

A. Influenca e lartesis se pellgut mbi nivelin e detit ne prurjet e reshjeve. Shmangia nga influenca e drejteperdrejte e elementeve hidraulike te pellgut

Formula Giandoti. $T_c = (4 * A^{1/2} + 1.5L) / 0.8Z^{1/2}$

Formula Vipareli $T_c = L / 0.4 * I^{1/2}$.

Eshte perzgjedhur formula Giandoti per llogaritje

A=51.4 km²

L=10.49 Km. Gjatesia mesatre e pellgut.

Z=910m. Lartesia mestare e pellgut shimblethes.

Me keto te dhena $T_c=1.93$ ore . Pranojme $T_c=2$ ore.

Nga perpunimi I te dhenave hidrologjike te stacionit Valbone rezultojne reshje maksimale 95mm shi per frekuence 2%. $I=47.5$ mm/ore. Rezultat te perafert nxjerrim nga kurbat IDF Razem Shkoder.

Prurja rezulton $Q=423$ M3/sek.

B. Manuali I Projektimit Hidraulik USA. Merret per baze influenca e elementeve hidraulik te pellgut shimblethes. Lartesia mbi nivelin e detit influencon ne menyre te terthorte.

Formula Bransby-Williams $T_c=21.3*L/A^{0.1}*S^{0.2}$.

Formula Kirpich $T_c=0.0078*L/S^{0.385}$.

Me e pershtatshme formula Bransby-Williams sepse merr me shume factor.

L=10.49 km. A=51.4 km² S=0.3 Pjerrsia mesatare e pellgut shimblethes. Referenca e mesiperme.

Nga perllogaritet $T_c= 189$ minuta afersisht 3 ore.

Formula Giandotti per pellgje shimblethes ne lartesi te medha dhe forme asimetrike te tyre jep rezultat me te sakte.

Pranojme $Q=423$ m3/sek. Prurja qe kalon ne sipërfaqen drite ne intersektimin e sipër

2. Llogaritja e prurjes qe kalon ne intersektimin e poshtem.

Kemi keto te dhena.

A=60.4 Km²

L=7.248 Km

Z=677 m

S=0.3 30%

A. Formula Giandotti . $T_c=2$ ore.

B. Formula Bransby- Williams. $T_c=128$ min $T_c=2$ ore

Rezulton se sa me shume ulet lartesia mbi nivelin e detit aq me shume perafrohen ket dy metoda qe perfaqsojne edhe dy shkolla.

$Q_{max}= Q_{siper} + Q_{reshje}$.

$Q_{reshje}=363$ M3/sek

Qtot=423+363=786M3/sek. Prurja maksimale ne pike e poshtme(Intersektimi I poshtem)

LLOGARITJE HIDRAULIKE.

A. Ne piken e sipërme. Intersektimi I rruges

$$Q=363 \text{ m}^3/\text{sek}$$

$$I=0.006 \text{ gradienti hidraulik } 0.6\%$$

Pranojme B=12M H=4M I=0.6% (Hapsira drite)

Formula Chezy: $V=C*(RI)^{1/2}$. C koeficienti CHEzy. R rrezja hidraulike I gradient hidraulik.

Per betone $n=0.017$ Koeficienti I Manningut

$S=48 \text{ M}^2 \text{ P}=20\text{M}$ $R=S/P=2.8$ Per $R=2.8$ dhe $n=0.017$ rezulton $C=68.64$ dhe $V=11.5\text{M}/\text{sek}$

$$Q=\omega * V=441 \text{ M}^3/\text{sek}$$

B. Ne piken e poshtme.

Me llogaritjet si me sipër:

Kemi keto permasa te hapsires drite: B=15M dhe H=4.5M I=0.01 1%.

8. MASAT INXHINIERIKE

Masat Inxhinierike qe do te merren per permiresimin e rruges ne keto segmente jane :

1. Segmenti 1 km 5+500

Ky segment ka gjatesi 180 ml dhe gjeresi te asfaltit ekzistues 3.8m. Ne kete segment nuk ka vepra arti qe te mundesojne kalimin e ujerave nga njera ane e rruges ne tjetren. Per kete arsye ne periudhat e reshjeve ujerat e perroit kalojne mbi shtresat rrugore. Aktualisht shtresat rrugore asfaltike jane demtuar dhe jane zevendesuar me beton ne forme solete.

Ne kete segment kemi parashikuar te ndertojme 3 tombino Box me dimensione 5x5 te cilat do te ndertohen ngjitur me njera tjetren. 3x(5x5) per te bere te mundur largimin e rrjedhes se perroit poshte trupit te rruges. Ndertimi i tombinos Box do te ngreje niveleten e rruges ne kete segment.

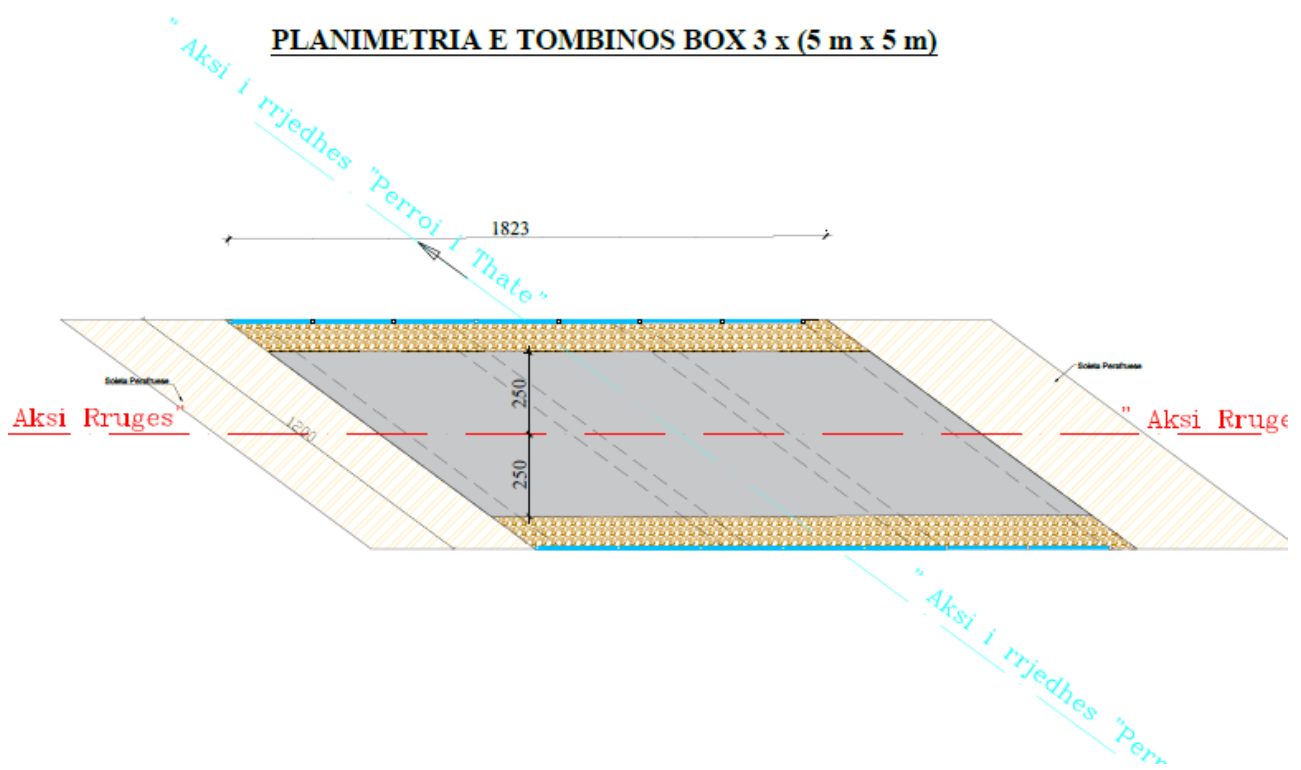

Punime te tjera te parashikuara jane ndertimi i shtresave rrugore ne kete segment me gjeresi asfalti 5m ne gjatesine prej 180 ml, ndetime mure mbajtes e prites, spostimin e 3 shtyllave te ndricimit jashte trupit te rruges, sinjalistike.

Profilat Tip per segmentin 1:

PROFIL TIP 1- Km 0+010 0+040

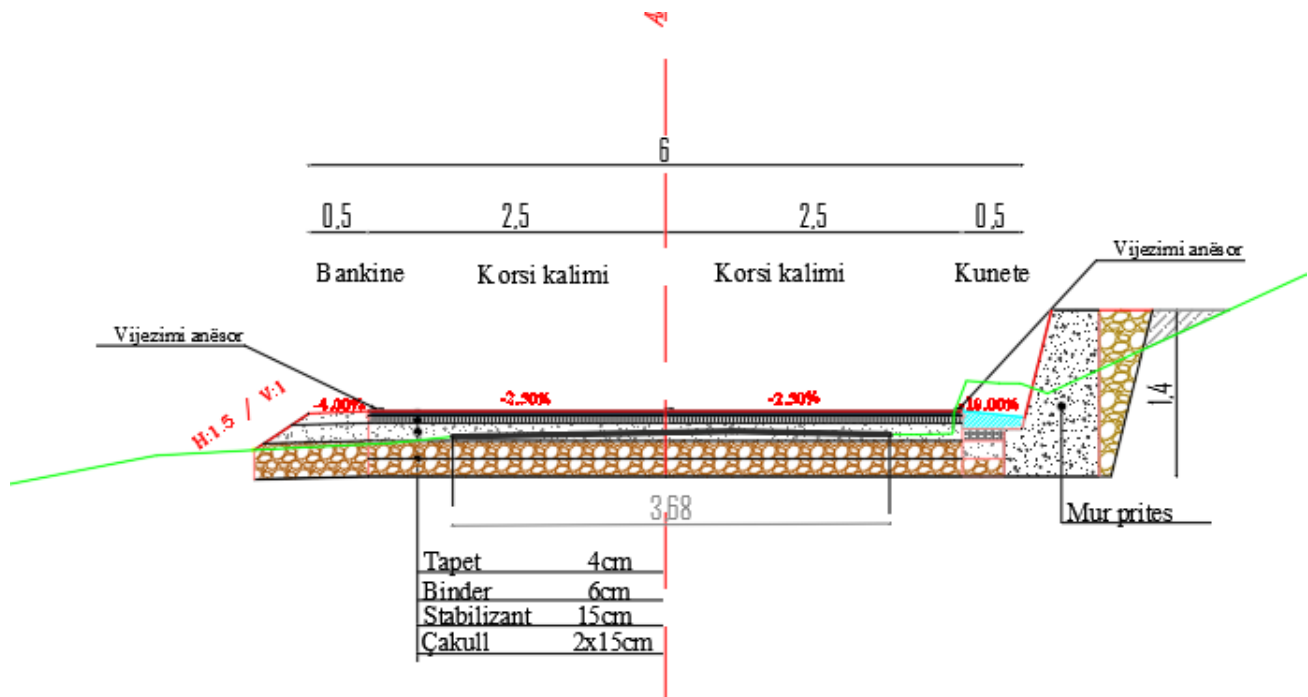

Ky profil do te aplikohet ne pjesen e pare te segmentit rrugor me gjatesi 40m. Ne kete segment kemi zgjerim te shtresave te reja dhe rakordim me rrugen ekzsituese.

PROFIL TIP 2- Km 0+080 – 0+100

Prerje Terthore e Tombinos Box 3x(5x5)

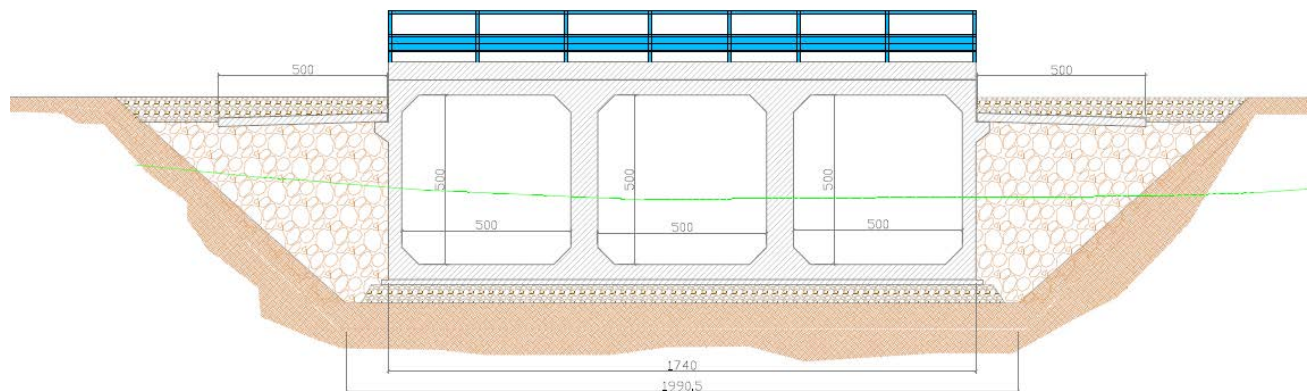

PROFIL TIP 3 - Km 0+050 0+110

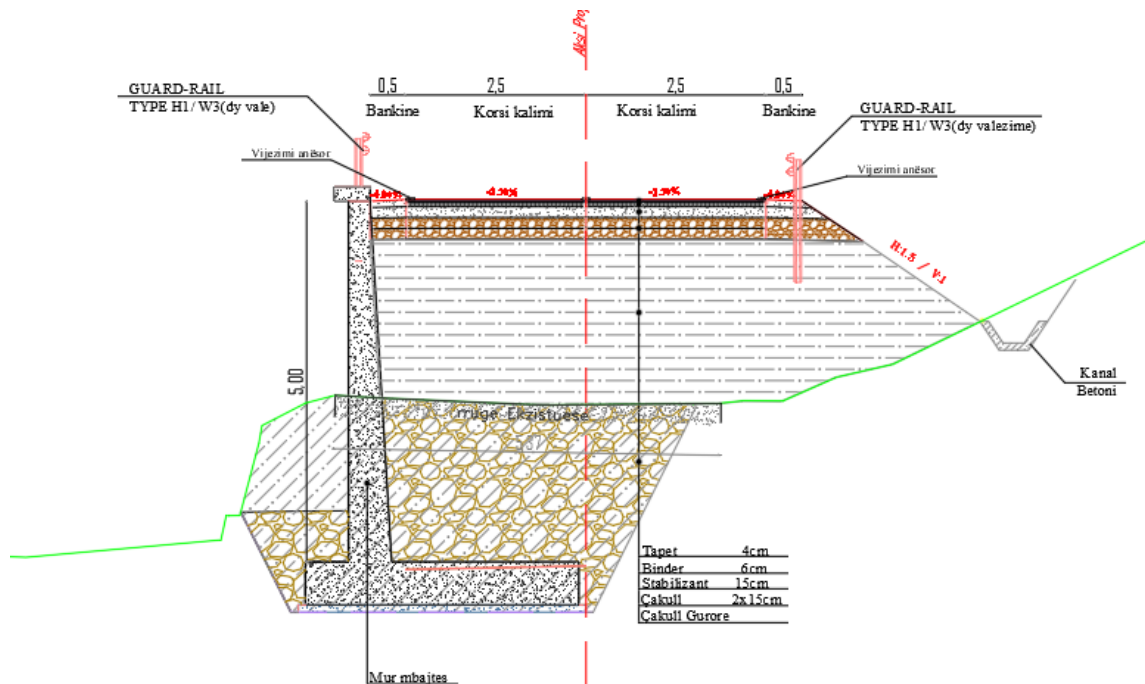

Ky profil aplikohet ne progresivat 0+050 – 0+110 me gjatesi prej 60ml. Ne kete segment trupi i rruges kalon ne mbushje per te arritur kuoten qe duhet per ndertimin e box. Ne pjesen ku rruga eshte ne mbushje shoqerohet me mur mbajtes me lartesi te ndryshueshme 2.5 – 5.5m.

PROFIL TIP 4 - Km 0+110 – 0+180

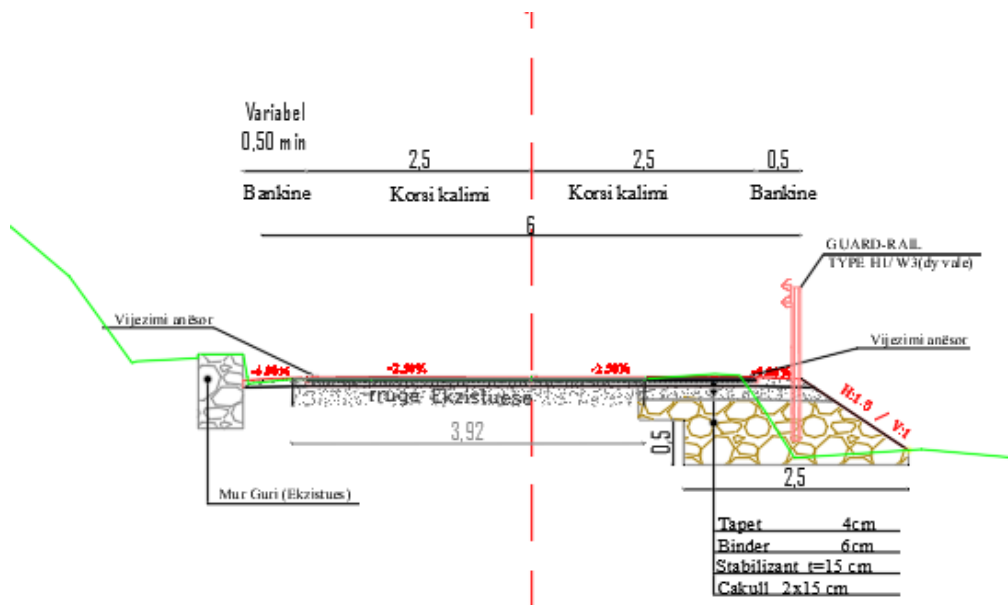

Ky profil aplikohet ne fundin e segmentit ne gjatesi prej 70 ml dhe kemi parashikuar zgjerimin e shtresave rrugore dhe rakordimin me rrugen ekzistuese.

2. Segmenti 2 km 13+000

Ky segment ka gjatesi 330 ml dhe gjeresi te asfaltit ekzistues 3.8m. Ne kete segment aktualisht ka 4 tombino rrethore me diamter Ø800mm. Ne periudhen e reshjeve keto tombino nuk e perballojne prurjen e perroit dhe uji kapercen mbi trupin e rruges. Edhe ne kete segment shtresat rrugore asfaltike jane demtuar dhe jane zevendesuar me beton ne forme solete.

Per kete segment kemi propozuar zgjerimin e rruges ku asfalti i ri do te jete 5 m. Ne km 0+190 – 0+220 eshte pika me e ulet e rruges ekzistuese kemi propozuar ndertimin e ures me gjatesi L=30m me 2 hapesira drite nga 15 m. Ura eshte propozuar me soletone te parapergatitur L=15m. Per kete arsye trupi i rruges do jete ne mbushje para dhe pas ures i mbrojtur me mure mbajtes gabjon.

Profilat Tip per segmentin 2

PROFIL TIP - Km 0+010 - 0+090

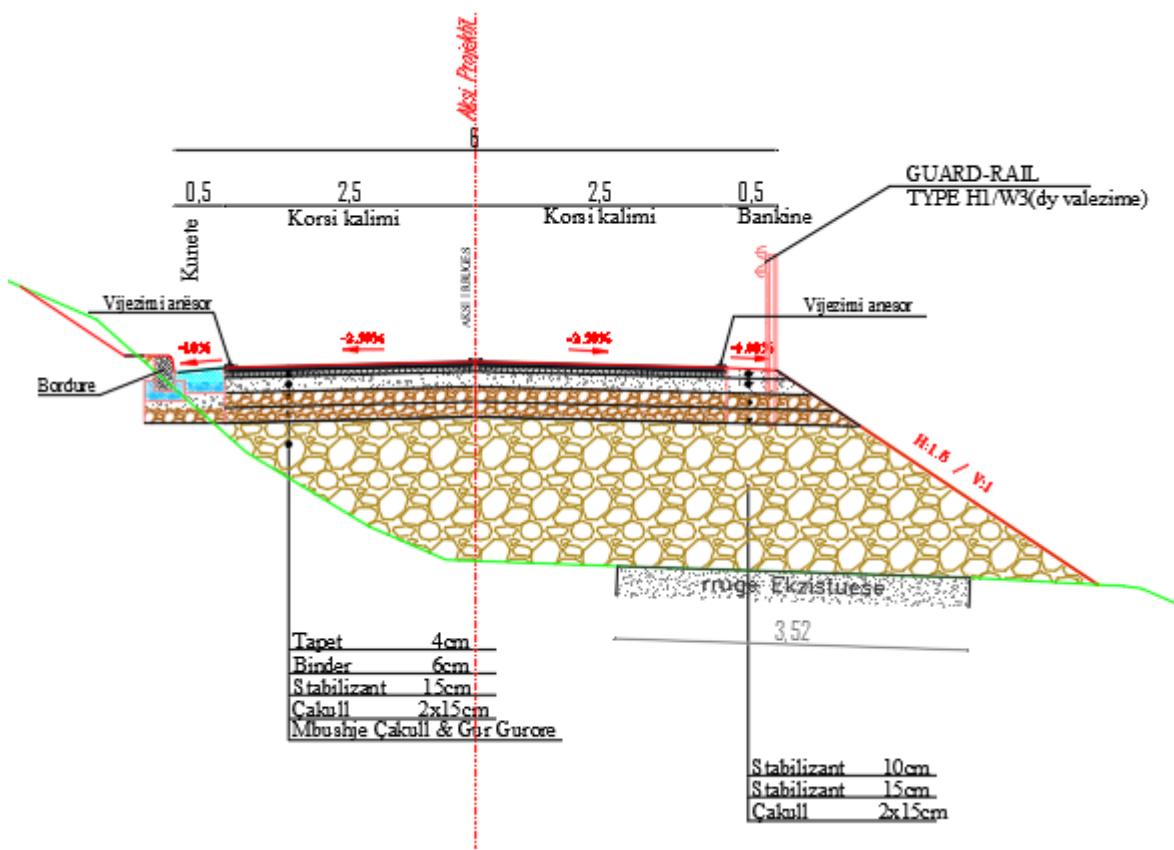

Ky profil aplikohet ne progresivat 0+010 – 0+090 ne nje gjatesi prej 80 ml. Ketu trupi i rruges kalon ne mbushje dhe kemi zgjerim te shtresave rrugore dhe rakordim me shtresat ekzistuese.

PROFIL TIP - Km 0+110 - 0+180

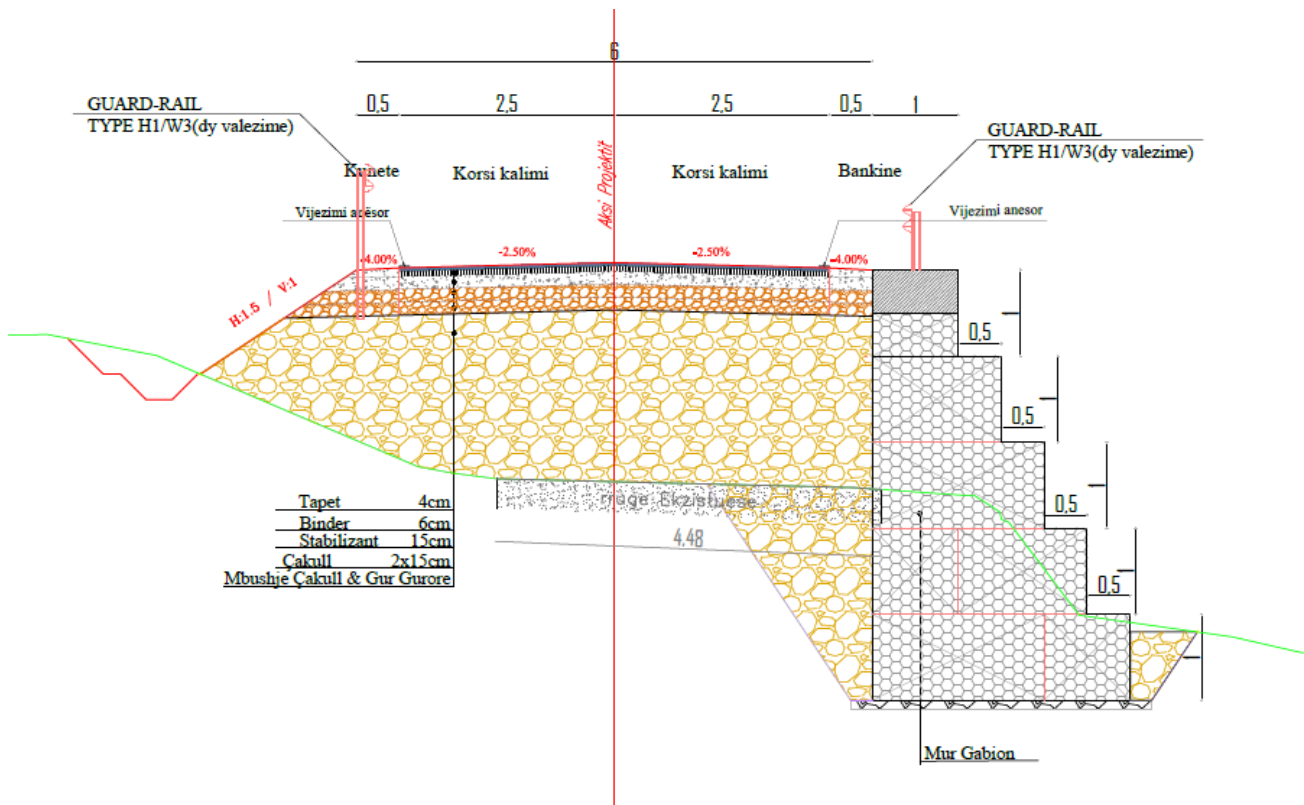

Ky profil tip do te aplikohet ne nje gjatesi prej 70 ml, trupi i rruges kalon ne mbushje per efekt te arritjes se kuotes per ndertimin e ures. Krahu i djathte i rruges eshte menduar te behet me gabion per shkak te mbrojtjes nga rrjedha e perroit. Gurët që do të përdoren për formimin e koshave të gabionave duhet të jenë të plotë, pa plasaritje, të fortë e të qëndrueshëm. Ata duhet të kenë rezistencë në shtypje mbi 500 kg/cm² dhe të aprovohen nga mbikqyerësi i punimeve. Gurët vendosen me kujdes me dorë për të siguruar një radhitje me minimumin e boshllëqeve. Gjatë vendosjes së gurëve duhet të sigurohet vertikalisiteti dhe horizontaliteti i murit. Shmangia e lejuar do të jetë jo më shumë e përmasës së koshit. Gurët duhet të jenë me përmasa jo më të vegjël se 10 cm dhe jo më të mëdhenj se 20 cm në drejtimin vertikal, jo më të vegjël se 20 cm dhe jo më të mëdhenjë se 50 cm në drejtimin horizontal. Gurët duhet të jenë të latuar e të puthiten mirë. Nuk lejohet përdorimi i gurëve të vegjël për mbajtjen apo pozicionimin e gurëve të gabionit. Gjithashtu nuk lejohet përdorimi i gurëve të rumbullakët (sferike). Faqet e dukshme të muraturës së gabionave do të punohen me dorë, në të njëjtën mënyrë si bëhet muratura në të thatë, duke respektuar të njëjtat parametra. Gjatë vendosjes së gurëve bëhet alternimi i vendosjes së tyre me telat bashkus dhe diagonalet (4 copë) me d = 2.4 mm. përballë njëra-tjetrës.

Vendosja e gabionave do të bëhet sipas vizatimeve të dhëna në projekt. Fugatura e blloqeve në asnjë rast nuk duhet të bjerë njëri mbi tjetrin dhe jo më afër se 40 cm. Gabionat me formë prizmatike me përmasa të ndryshme, do të ndërtohen me rrjetë teli të zinguar me hoje gjashtëkëndore me përdredhje të dyfishtë.

Pesha e e rrjetës së gabionit të prodhuar duhet të jetë: $P \geq 1.750 \text{ kg/m}^2$.

PROFIL TIP URE L=30M - Km 0+190 0+220

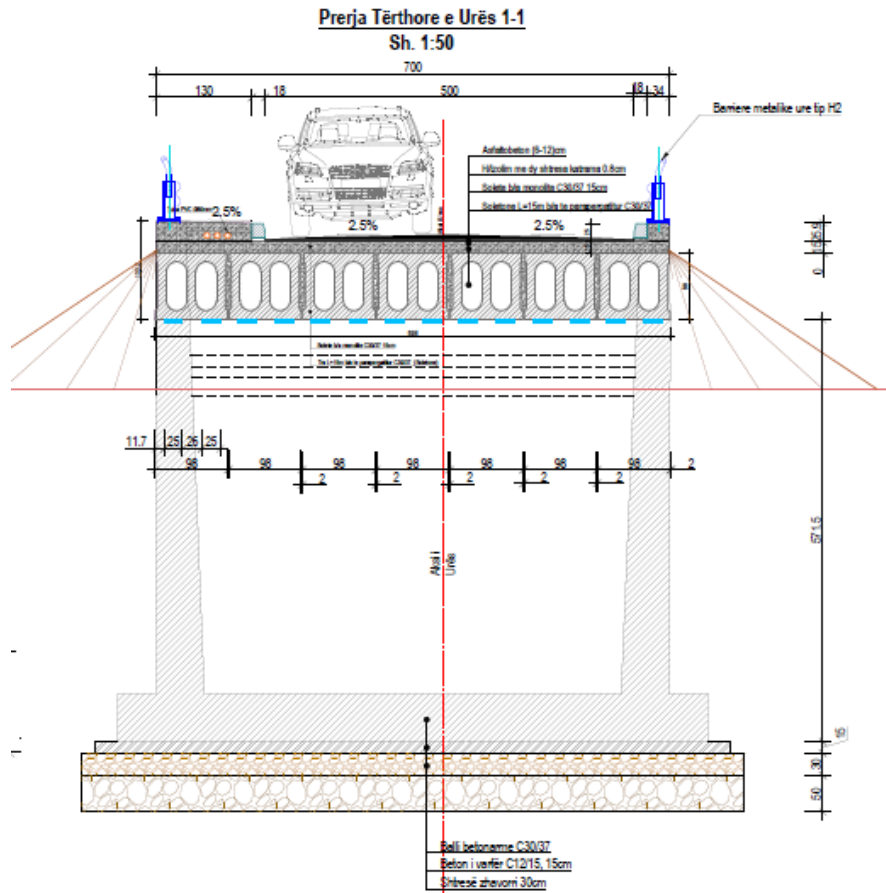

PROFIL TIP - Km 0+230 0+240

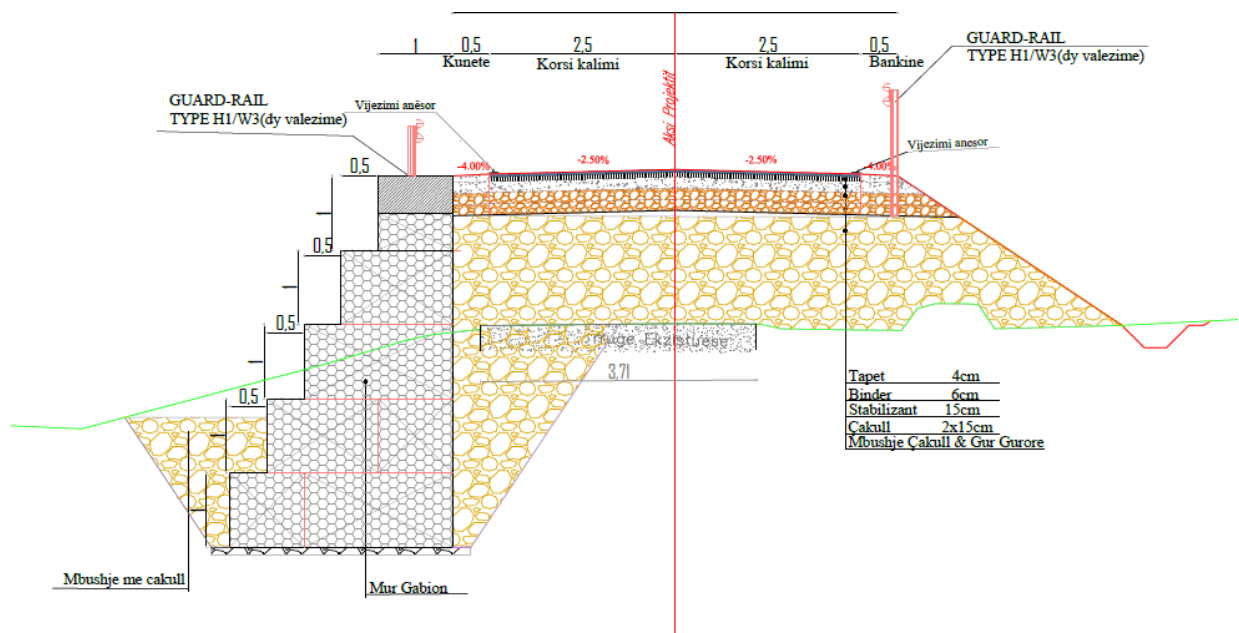

Ky profil aplikohet ne dalje te ures dhe trupi i rruges eshte ne mbushje. Krahu i majte i rruges eshte i mbrojtur me mur gabion.

URE L=30 m

Ura me gjatesi L=30 m eshte propozuar me 2 hapesira drite nga 15 m. Ura mbeshtetet mbi 2 shtatulla me lartesi 4.95 m bashke me jastekun dhe pila me lartesi 5.2 m bashke me jastekun. Mbistruktura e ures eshte propozuar me soletone te parapergatitur L=15m.

Ne kete segment eshte parashikuar pastrimi i shtratit te perroit dhe ndertimi i mureve gabjon per mbrotjen e trupit te rruges nga vershimi i perroit ne periudhen e prurjeve maksimale.

Punime te tjera te parashikuara ne kete segment jane ndertimi i shtresave te reja rrugore, spostimi i 3 shtyllave te ndricimit jashte trupit te rruges, plotesim me sinjalistike.

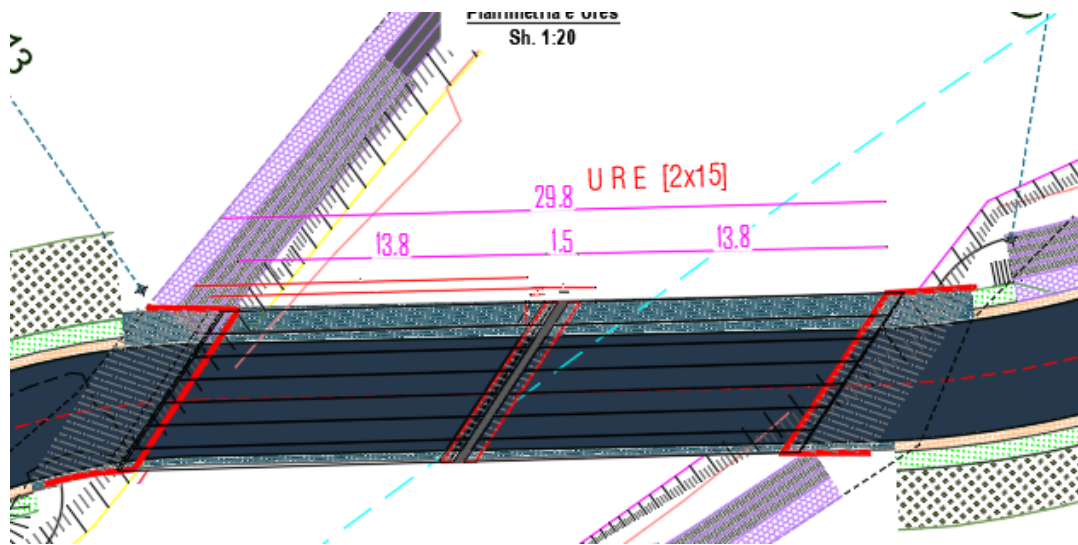

Pamje Gjatësore A-A e Urës
Sh. 1:50

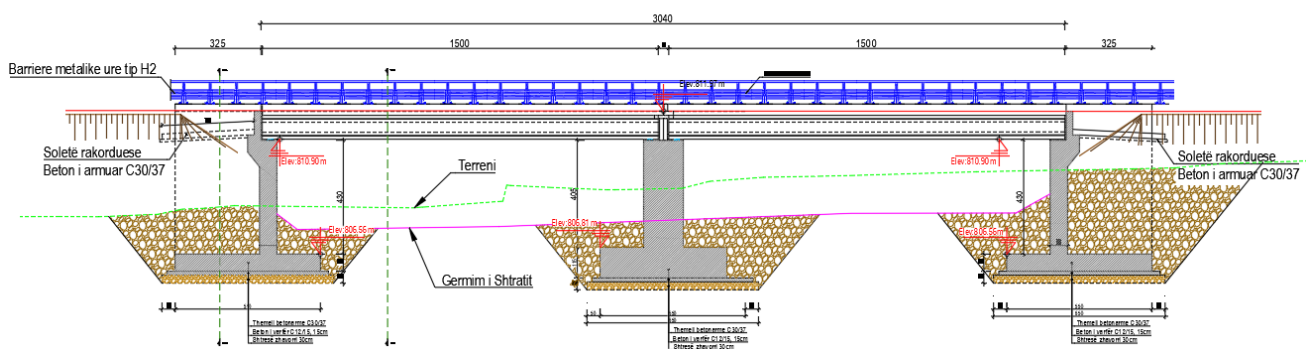

LLOGARITJET KONSTRUKTIVE TE MURIT MBAJTES

Mure Mbjates jane ndertuar ne ato raste kur eshte gjykuar e nevojshme mbajtja e trupit te rruges. Trupi i rruges perbehet nga materialet mbushese te ngjeshura , nga shtresat e paketes se nen bazes, nga shtresat e ngjeshura te bazes dhe nga shtresat asfaltike.

Ngarkesat qe ushtrohen ne trupin e rruges nga ana e materialeve qe permendem (ngarkesa statike) si dhe ngarkesat dinamike qe ushtrohen nga trafiku i automjeteve, gjate perdorimit te rruges, jane bazat per llogaritjen e mureve mbajtese ne trup te rruges.

Rezultatet e projektimit dhe analizës së stabilitetit të mureve realizohen me software-in "GeoStructural Retaining Wall Analysis"

Ky program kryen analizat e mëposhtme lidhur me:

Stabilitetin e përgjithshëm të murit:

- Stabilitet në rrëshqitje**
- Stabilitet në përmbysje**
- Stabilitet global**
- Kapacitet mbajtës**

Kontrolli nga rrëshqitja bëhet duke krahasuar rezultanten e forcave të jashtme horizontale që veprojnë në strukturën tonë të shumëzuar me koeficientët përkatës referuar Eurocode, me shumatoren e të gjitha forcave vertikale që ndihmojnë në stabilitetin e strukturës nga rrëshqitja shumëzuar me koeficientin e fërkimit i cili përcaktohet në funksion të këndit të fërkimit të dheut ku mbështetet struktura jonë.

Stabiliteti në përmbysje kontrollohet duke verifikuar që momenti përmbysës i shkaktuar nga forcat që veprojnë në strukturën tonë kundrejt qendrës së mundshme kundrejt të cilës ndodh përmbysja e murit si në figurë, nuk e kalon vlerën e momentit mbajtës.

Të dyja këto kushte janë të lidhura drejtpërdrejt me kontrollin dhe verifikimin e dimensioneve, gjeometrisë së murit.

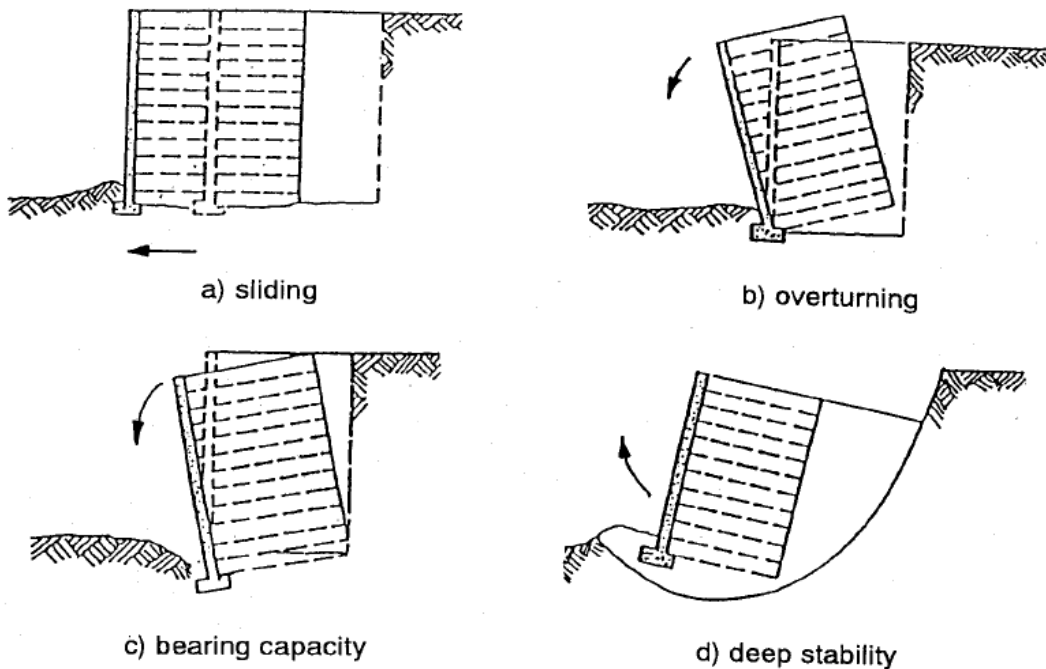

Stabiliteti global kontrollohet sipas sipërfaqeve rrethore të rrëshqitjes, referuar metodës Bishop për përcaktimin dhe optimizimin e saj.

Kapaciteti mbajtës i dheut ku mbështetet muri është përcaktuar me metodën e Terzaghi-t, referuar karakteristikeve të shtresës në bazë sipas raportit gjeologjik.

Rezultatet e ketyre analizave të gjeneruara nga programi paraqiten si Aneks i raportit teknik për llogaritjen nga ana konstruktive të strukturave.

Cantilever wall analysis

Input data

Project

Author : GJEO KONSULT & CO
 Date : 5/9/2022
 Project ID : MUR MBAJTES B/A H=3 ÷ 6m
 Unit weight of water is considered : 9,81 kN/m³

Settings

(input for current task)

Materials and standards

Concrete structures : EN 1992-1-1 (EC2)
 Coefficients EN 1992-1-1 : standard

Wall analysis

Active earth pressure calculation : Coulomb
 Passive earth pressure calculation : Coulomb
 Earthquake analysis : Mononobe-Okabe
 Shape of earth wedge : Calculate as skew
 Base key : The base key is considered as inclined footing bottom
 Allowable eccentricity : 0.333
 Verification methodology : according to EN 1997

Design approach : 3 - reduction of actions (GEO, STR) and soil parameters

Partial factors on actions (A)					
Permanent design situation					
		State STR		State GEO	
		Unfavourable	Favourable	Unfavourable	Favourable
Permanent actions :	$\gamma_G =$	1.35 [-]	1.00 [-]	1.00 [-]	1.00 [-]
Variable actions :	$\gamma_Q =$	1.50 [-]	0.00 [-]	1.30 [-]	0.00 [-]
Water load :	$\gamma_w =$			1.00 [-]	

Partial factors for soil parameters (M)		
Permanent design situation		
Partial factor on internal friction :	$\gamma_\phi =$	1.25 [-]
Partial factor on effective cohesion :	$\gamma_c =$	1.25 [-]
Partial factor on undrained shear strength :	$\gamma_{cu} =$	1.40 [-]
Partial factor on Poisson's ratio :	$\gamma_v =$	1.00 [-]

Partial factors for variable actions		
Permanent design situation		
Factor for combination value :	$\psi_0 =$	0.70 [-]
Factor for frequent value :	$\psi_1 =$	0.50 [-]
Factor for quasi-permanent value :	$\psi_2 =$	0.30 [-]

Partial factors on actions (A)					
Seismic design situation					
		State STR		State GEO	
		Unfavourable	Favourable	Unfavourable	Favourable
Permanent actions :	$\gamma_G =$	1.00 [-]	1.00 [-]	1.00 [-]	1.00 [-]
Variable actions :	$\gamma_Q =$	1.00 [-]	0.00 [-]	1.00 [-]	0.00 [-]
Water load :	$\gamma_w =$			1.00 [-]	

Partial factors for soil parameters (M)		
Seismic design situation		
Partial factor on internal friction :	$\gamma_\phi =$	1.00 [-]
Partial factor on effective cohesion :	$\gamma_c =$	1.00 [-]
Partial factor on undrained shear strength :	$\gamma_{cu} =$	1.00 [-]
Partial factor on Poisson's ratio :	$\gamma_v =$	1.00 [-]

Material of structure

Unit weight $\gamma = 25.00 \text{ kN/m}^3$

Analysis of concrete structures carried out according to the standard EN 1992-1-1 (EC2).

Concrete : C 25/30

Cylinder compressive strength

$$f_{ck} = 25.00 \text{ MPa}$$

Tensile strength

$$f_{ctm} = 2.60 \text{ MPa}$$

Longitudinal steel : B500`

Yield strength

$$f_{yk} = 500.00 \text{ MPa}$$

Geometry of structure

No.	Coordinate X [m]	Depth Z [m]
1	0.00	0.00
2	0.29	5.00
3	2.89	5.00
4	2.89	5.60
5	-1.00	5.60
6	-1.00	5.00
7	-0.30	5.00
8	-0.30	0.00

The origin [0,0] is located at the most upper right point of the wall.
Wall section area = 4.60 m².

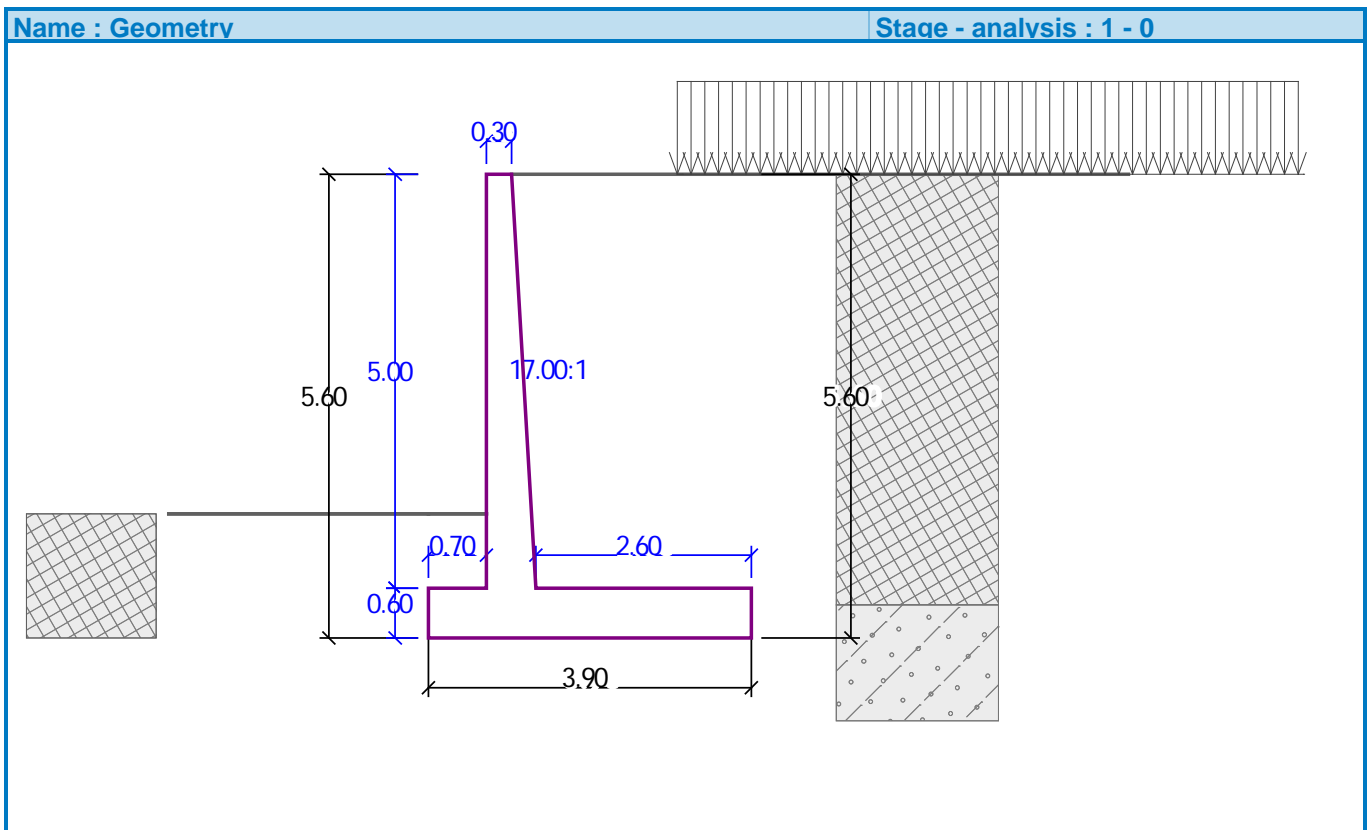

Basic soil parameters

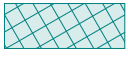
No.	Name	Pattern	φ_{ef} [°]	c_{ef} [kPa]	γ [kN/m ³]	γ_{su} [kN/m ³]	δ [°]
1	Shtresa 3. Perfaqesohet nga depozitime magmatike, ultrabazike, dunite. Takohen nga sipërfaqja mbas thellesise 4 - 5 m		32.00	0.00	24.81	15.00	15.00
2	Mbushje		35.00	0.00	19.00	10.19	23.00

No.	Name	Pattern	φ_{ef} [°]	C_{ef} [kPa]	γ [kN/m ³]	γ_{su} [kN/m ³]	δ [°]
3	Shtresa 2 Perfaqesohet nga argjila e surera te perziera me brekcie dhe zaje te rumbullakosura , ngjyre kafe. Jane pak te ngjeshura.		35.00	14.70	18.37	11.32	12.00

All soils are considered as cohesionless for at rest pressure analysis.

Soil parameters

Shtresa 3.Perfaqesohet nga depozitime magmatike, ultrabazike, dunite.Takohen nga siperfaqja mbas thellesise 4 - 5 m

Unit weight : $\gamma = 24.81 \text{ kN/m}^3$
 Stress-state : effective
 Angle of internal friction : $\varphi_e = 32.00^\circ$
 f
 Cohesion of soil : $C_{ef} = 0.00 \text{ kPa}$
 Angle of friction struc.-soil : $\delta = 15.00^\circ$
 Soil : cohesionless
 Solid unit weight : $\gamma_s = 24.81 \text{ kN/m}^3$
 Porosity <0.0 - 1.0> : $n = 0.00$



Mbushje

Unit weight : $\gamma = 19.00 \text{ kN/m}^3$
 Stress-state : effective
 Angle of internal friction : $\varphi_{ef} = 35.00^\circ$
 Cohesion of soil : $C_{ef} = 0.00 \text{ kPa}$
 Angle of friction struc.-soil : $\delta = 23.00^\circ$
 Soil : cohesionless
 Saturated unit weight : $\gamma_{sat} = 20.00 \text{ kN/m}^3$

Shtresa 2 Perfaqesohet nga argjila e surera te perziera me brekcie dhe zaje te rumbullakosura , ngjyre kafe. Jane te ngjeshura.

Unit weight : $\gamma = 18.37 \text{ kN/m}^3$
 Stress-state : effective
 Angle of internal friction : $\varphi_{ef} = 35.00^\circ$
 Cohesion of soil : $C_{ef} = 14.70 \text{ kPa}$
 Angle of friction struc.-soil : $\delta = 12.00^\circ$
 Soil : cohesionless
 Saturated unit weight : $\gamma_{sat} = 21.13 \text{ kN/m}^3$

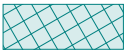
Geological profile and assigned soils

No.	Layer [m]	Assigned soil	Pattern
1	5.20	Mbushje	
2	4.80	Shtresa 3.Perfaqesohet nga depozitime magmatike, ultrabazike, dunite.Takohen nga siperfaqja mbas thellesise 4 - 5 m	
3	-	Shtresa 3.Perfaqesohet nga depozitime magmatike, ultrabazike, dunite.Takohen nga siperfaqja mbas thellesise 4 - 5 m	

Foundation

Type of foundation : soil from geological profile

Terrain profile

Terrain behind the structure is flat.

Water influence

Ground water table is located below the structure.

Input surface surcharges

No.	Surcharge		Action	Mag.1 [kN/m ²]	Mag.2 [kN/m ²]	Ord.x x [m]	Length l [m]	Depth z [m]
	new	change						
1	YES		variable	4.00		2.00	7.50	on terrain

No.	Name
1	Ngarkesa e Trafikut

Resistance on front face of the structure

Resistance on front face of the structure: at rest

Soil on front face of the structure - Mbushje

Soil thickness in front of structure $h = 1.50$ m

Terrain in front of structure is flat.

Settings of the stage of construction

Design situation : permanent

The wall is free to move. Active earth pressure is therefore assumed.

Verification No. 1 (Stage of construction 1)

Forces acting on construction

Name	F_{hor} [kN/m]	App.Pt. z [m]	F_{vert} [kN/m]	App.Pt. x [m]	Coeff. overtur.	Coeff. sliding	Coeff. stress
Weight - wall	0.00	-1.54	114.97	1.45	1.000	1.000	1.350
FF resistance	-10.92	-0.50	0.02	0.35	1.000	1.000	1.000
Weight - earth wedge	0.00	-2.43	137.33	2.07	1.000	1.000	1.000
Active pressure	100.98	-1.88	129.12	3.07	1.000	1.000	1.000
Ngarkesa e Trafikut	3.35	-2.14	4.17	2.87	1.300	1.300	1.300

Verification of complete wall

Check for overturning stability

Resisting moment $M_{res} = 862.03$ kNm/m

Overturning moment $M_{ovr} = 193.76$ kNm/m

Wall for overturning is SATISFACTORY

Check for slip

Resisting horizontal force $H_{res} = 193.39$ kN/m

Active horizontal force $H_{act} = 94.41$ kN/m

Wall for slip is SATISFACTORY

Overall check - WALL is SATISFACTORY

Maximum stress in footing bottom : 125.52 kPa

Bearing capacity of foundation soil (Stage of construction 1)

Design load acting at the center of footing bottom

No.	Moment [kNm/m]	Norm. force [kN/m]	Shear Force [kN/m]	Eccentricity [-]	Stress [kPa]
1	105.97	427.10	94.41	0.064	125.52
2	85.89	386.86	94.41	0.057	111.97

Service load acting at the center of footing bottom

No.	Moment [kNm/m]	Norm. force [kN/m]	Shear Force [kN/m]
1	44.71	384.25	73.08

Verification of foundation soil

Eccentricity verification

Max. eccentricity of normal force $e = 0.064$

Maximum allowable eccentricity $e_{alw} = 0.333$

Eccentricity of the normal force is SATISFACTORY

Verification of bearing capacity

Max. stress at footing bottom $\sigma = 125.52$ kPa

Bearing capacity of foundation soil $R_d = 392.00$ kPa

Bearing capacity of foundation soil is SATISFACTORY

Overall verification - bearing capacity of found. soil is SATISFACTORY

Dimensioning No. 1 (Stage of construction 1)

Forces acting on construction

Name	F_{hor} [kN/m]	App.Pt. z [m]	F_{vert} [kN/m]	App.Pt. x [m]	Design coefficient
Weight - wall	0.00	-0.30	39.00	2.60	1.350
Weight - earth wedge	0.00	-2.43	137.33	2.07	1.000
Active pressure	100.98	-1.88	129.12	3.07	1.000
Ngarkesa e Trafikut	3.35	-2.14	4.17	2.87	1.300
Contact stress	0.00	0.00	-248.58	2.47	1.000

Back wall jump check

Reinforcement and dimensions of the cross-section

Bar diameter = 16.0 mm

Number of bars = 7

Reinforcement cover = 50.0 mm

Cross-section width = 1.00 m

Cross-section depth = 0.60 m

Reinforcement ratio $\rho = 0.26 \% > 0.14 \% = \rho_{min}$

Position of neutral axis $x = 0.05 \text{ m} < 0.33 \text{ m} = x_{max}$

Ultimate shear force $V_{Rd} = 195.03 \text{ kN} > 75.94 \text{ kN} = V_{Ed}$

Ultimate moment $M_{Rd} = 320.43 \text{ kNm} > 118.84 \text{ kNm} = M_{Ed}$

Cross-section is SATISFACTORY.

Slope stability analysis

Input data

Project

Settings

(input for current task)

Stability analysis

Earthquake analysis : Standard

Verification methodology : according to EN 1997

Design approach : 3 - reduction of actions (GEO, STR) and soil parameters

Partial factors on actions (A)					
Permanent design situation					
		State STR		State GEO	
		Unfavourable	Favourable	Unfavourable	Favourable
Permanent actions :	$\gamma_G =$	1.35 [-]	1.00 [-]	1.00 [-]	1.00 [-]
Variable actions :	$\gamma_Q =$	1.50 [-]	0.00 [-]	1.30 [-]	0.00 [-]
Water load :	$\gamma_w =$			1.00 [-]	

Partial factors for soil parameters (M)		
Permanent design situation		
Partial factor on internal friction :	$\gamma_\phi =$	1.25 [-]
Partial factor on effective cohesion :	$\gamma_c =$	1.25 [-]
Partial factor on undrained shear strength :	$\gamma_{cu} =$	1.40 [-]

Interface

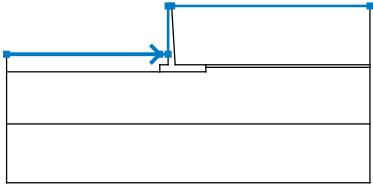
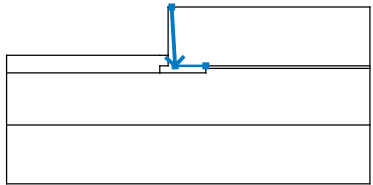
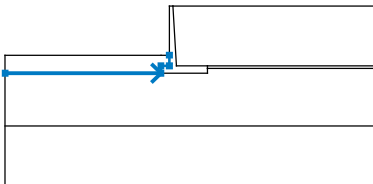

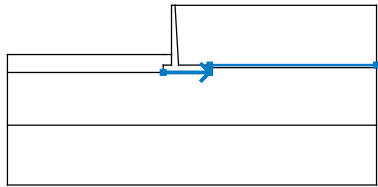
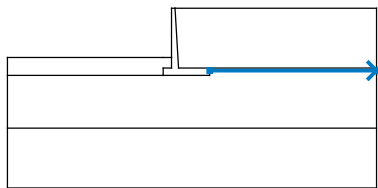
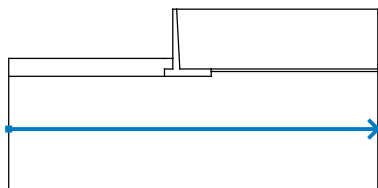
No.	Interface location	Coordinates of interface points [m]					
		x	z	x	z	x	z
1		-14.00	-4.10	-1.00	-4.10	-0.30	-4.10
		-0.30	0.00	0.00	0.00	16.80	0.00
2		0.00	0.00	0.29	-5.00	2.89	-5.00
3		-14.00	-5.60	-1.00	-5.60	-1.00	-5.00
		-0.30	-5.00	-0.30	-4.10		

No.	Interface location	Coordinates of interface points [m]					
		x	z	x	z	x	z
4		-1.00	-5.60	2.89	-5.60	2.89	-5.20
		2.89	-5.00	16.80	-5.00		
5		2.89	-5.20	16.80	-5.20		
6		-14.00	-10.00	16.80	-10.00		

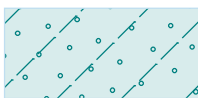
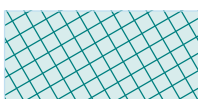
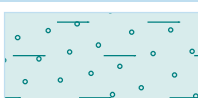
Soil parameters - effective stress state

No.	Name	Pattern	φ_{ef} [°]	c_{ef} [kPa]	γ [kN/m ³]
1	Shtresa 3. Perfaqesohet nga depozitime magmatike, ultrabazike, dunite. Takohen nga siperfaqja mbas thellesise 4 - 5 m		32.00	0.00	24.81
2	Mbushje		35.00	0.00	19.00
3	Shtresa 2 Perfaqesohet nga argjila e surera te perziera me brekcie dhe zaje te rrumbullakosura , ngjyre kafe. Jane pak te ngjeshura.		35.00	14.70	18.37

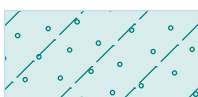
Soil parameters - uplift

No.	Name	Pattern	γ_{sat} [kN/m ³]	γ_s [kN/m ³]	n [-]
1	Shtresa 3. Perfaqesohet nga depozitime magmatike, ultrabazike, dunite. Takohen nga siperfaqja mbas thellesise 4 - 5 m			24.81	0.00
2	Mbushje		20.00		
3	Shtresa 2 Perfaqesohet nga argjila e surera te perziera me brekcie dhe zaje te rrumbullakosura , ngjyre kafe. Jane pak te ngjeshura.		21.13		

Soil parameters

Shtresa 3. Perfaqesohet nga depozitime magmatike, ultrabazike, dunite. Takohen nga siperfaqja mbas thellesise 4 - 5 m

Unit weight : $\gamma = 24.81 \text{ kN/m}^3$

Stress-state : effective
 Angle of internal friction : $\varphi_{ef} = 32.00^\circ$
 Cohesion of soil : $c_{ef} = 0.00 \text{ kPa}$
 Solid unit weight : $\gamma_s = 24.81 \text{ kN/m}^3$
 Porosity <0.0 - 1.0> : $n = 0.00$

Mbushje

Unit weight : $\gamma = 19.00 \text{ kN/m}^3$
 Stress-state : effective
 Angle of internal friction : $\varphi_{ef} = 35.00^\circ$
 Cohesion of soil : $c_{ef} = 0.00 \text{ kPa}$
 Saturated unit weight : $\gamma_{sat} = 20.00 \text{ kN/m}^3$



Shtresa 2 Perfaqesohet nga argjila e surera te perziera me brekcie dhe zaje te rumbullakosura , ngjyre kafe. Jane pak te ngjeshura.



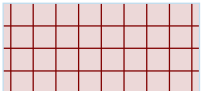

Unit weight : $\gamma = 18.37 \text{ kN/m}^3$
 Stress-state : effective
 Angle of internal friction : $\varphi_{ef} = 35.00^\circ$
 Cohesion of soil : $c_{ef} = 14.70 \text{ kPa}$
 Saturated unit weight : $\gamma_{sat} = 21.13 \text{ kN/m}^3$

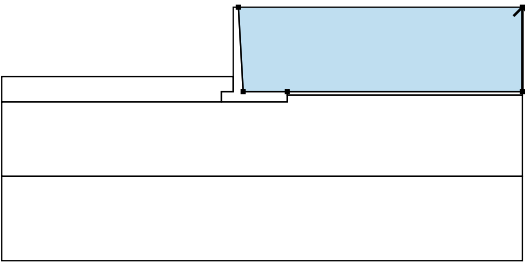
Rigid bodies

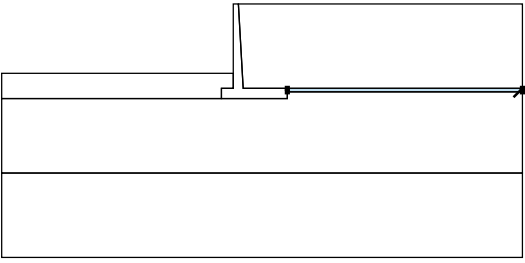
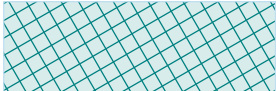
No.	Name	Sample	γ [kN/m ³]
1	Wall material		25.00

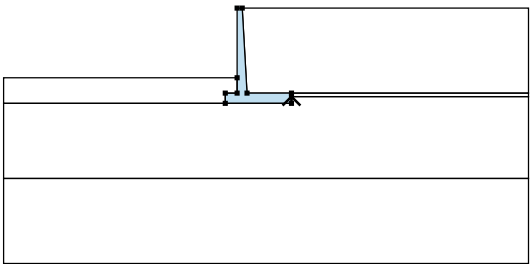
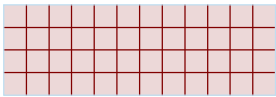
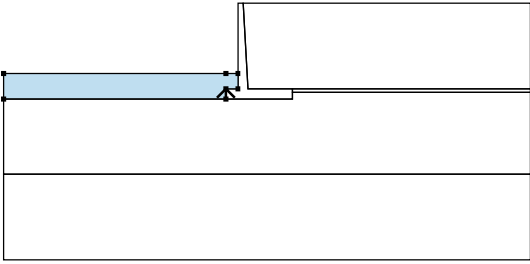
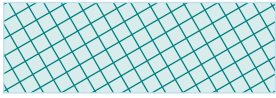
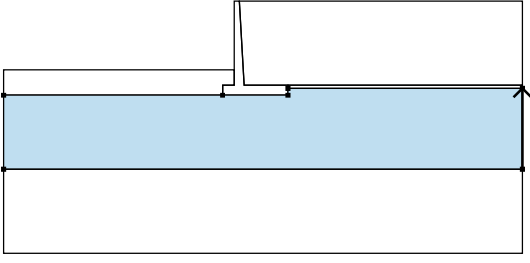
Assigning and surfaces

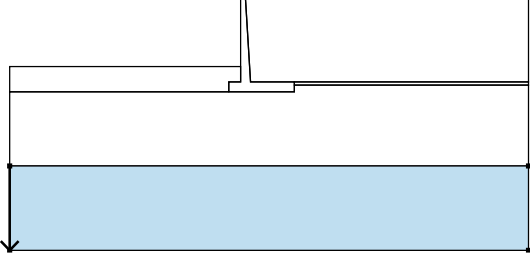
No.	Surface position	Coordinates of surface points [m]				Assigned soil
		x	z	x	z	
1		16.80	-5.00	16.80	0.00	Mbushje 
		0.00	0.00	0.29	-5.00	
		2.89	-5.00			
2		16.80	-5.20	16.80	-5.00	Mbushje 
		2.89	-5.00	2.89	-5.20	

No.	Surface position	Coordinates of surface points [m]				Assigned soil
		x	z	x	z	
3		2.89	-5.60	2.89	-5.20	Wall material 
		2.89	-5.00	0.29	-5.00	
		0.00	0.00	-0.30	0.00	
		-0.30	-4.10	-0.30	-5.00	
		-1.00	-5.00	-1.00	-5.60	
4		-1.00	-5.60	-1.00	-5.00	Mbushje 
		-0.30	-5.00	-0.30	-4.10	
		-1.00	-4.10	-14.00	-4.10	
		-14.00	-5.60			
5		16.80	-10.00	16.80	-5.20	Shtresa 3.Perfaqesohet nga depozitime magmatike, 
		2.89	-5.20	2.89	-5.60	
		-1.00	-5.60	-14.00	-5.60	
		-14.00	-10.00			
6		-14.00	-10.00	-14.00	-15.00	Shtresa 3.Perfaqesohet nga depozitime magmatike, 
		16.80	-15.00	16.80	-10.00	

Surcharge

No.	Type	Type of action	Location z [m]	Origin x [m]	Length l [m]	Width b [m]	Slope α [°]	Magnitude	
								q, q ₁ , f, F	q ₂ unit
1	strip	variable	on terrain	x = 2.00	l = 7.50		0.00	20.00	kN/m ²

Surcharges

No.	Name
1	Ngarkesa e Trafikut

Water

Water type : No water

Tensile crack

Tensile crack not inputted.

Earthquake

Earthquake not included.

Settings of the stage of construction

Design situation : permanent

Results (Stage of construction 1)

Analysis 1

Circular slip surface

Slip surface parameters					
Center :	x =	-0.92 [m]	Angles :	$\alpha_1 =$	-40.27 [°]
	z =	3.24 [m]		$\alpha_2 =$	70.32 [°]
Radius :	R =	9.62 [m]			
The slip surface after optimization.					

Slope stability verification (Bishop)

Sum of active forces : $F_a = 371.97$ kN/m

Sum of passive forces : $F_p = 632.99$ kN/m

Sliding moment : $M_a = 3578.39$ kNm/m

Resisting moment : $M_p = 6089.36$ kNm/m

Utilization : 58.8 %

Slope stability ACCEPTABLE

Optimization of circular slip surface (Bishop)

No.	Center		Radius R [m]	Utilization	Verification
	x [m]	z [m]			
1	-0.92	3.24	9.62	58.8 %	ACCEPTABLE
2	-0.92	3.24	9.62	58.8 %	ACCEPTABLE
3	-0.92	3.24	9.62	58.8 %	ACCEPTABLE
4	-2.60	18.69	25.15	35.6 %	ACCEPTABLE
5	-1.50	11.35	19.39	30.9 %	ACCEPTABLE
6	5.16	3.24	9.62	0.6 %	ACCEPTABLE
7	-0.13	2.13	14.50	18.7 %	ACCEPTABLE
8	-7.90	4.33	10.86	1.1 %	ACCEPTABLE
9	-7.00	3.24	9.62	1.2 %	ACCEPTABLE
10	-2.59	18.61	25.07	35.7 %	ACCEPTABLE
11	-59.02	124.63	138.79	0.3 %	ACCEPTABLE
12	-109.94	589.03	601.97	1.7 %	ACCEPTABLE
13	-52.94	124.63	138.79	2.3 %	ACCEPTABLE
14	-0.92	3.24	9.62	58.8 %	ACCEPTABLE
15	-71.59	409.06	417.55	1.1 %	ACCEPTABLE
16	-44.41	180.40	189.07	2.1 %	ACCEPTABLE
17	-2.16	13.12	19.45	40.1 %	ACCEPTABLE
18	-1.39	8.75	16.16	35.7 %	ACCEPTABLE
19	3.13	3.24	9.62	4.0 %	ACCEPTABLE
20	-0.27	2.32	12.67	28.1 %	ACCEPTABLE
21	-8.47	16.25	20.53	1.9 %	ACCEPTABLE
22	-27.91	47.64	57.38	1.9 %	ACCEPTABLE
23	-4.97	3.24	9.62	1.5 %	ACCEPTABLE
24	-4.27	0.61	8.37	3.0 %	ACCEPTABLE
25	-2.05	12.51	18.96	39.7 %	ACCEPTABLE
26	3.34	2.46	9.18	25.3 %	ACCEPTABLE
27	-66.70	176.36	190.04	0.6 %	ACCEPTABLE
28	-100.98	485.96	498.97	1.5 %	ACCEPTABLE
29	-62.65	176.36	190.04	1.8 %	ACCEPTABLE
30	-0.92	3.24	9.62	58.8 %	ACCEPTABLE

No.	Center		Radius R [m]	Utilization	Verification
	x [m]	z [m]			
31	2.45	0.74	8.42	26.5 %	ACCEPTABLE
32	-6.58	33.69	37.93	2.4 %	ACCEPTABLE
33	-2.11	17.73	21.95	2.7 %	ACCEPTABLE
34	-1.81	9.60	15.88	20.8 %	ACCEPTABLE
35	-1.29	6.98	14.00	46.7 %	ACCEPTABLE
36	1.78	3.24	9.62	35.6 %	ACCEPTABLE
37	-0.40	2.51	11.52	35.1 %	ACCEPTABLE
38	-5.36	9.72	14.53	3.3 %	ACCEPTABLE
39	-3.08	6.57	10.76	3.3 %	ACCEPTABLE
40	-3.62	3.24	9.62	2.2 %	ACCEPTABLE
41	-3.22	1.73	8.82	3.2 %	ACCEPTABLE
42	-1.69	8.99	15.42	50.0 %	ACCEPTABLE
43	1.77	3.29	9.65	35.7 %	ACCEPTABLE
44	-72.13	216.55	230.02	0.8 %	ACCEPTABLE
45	-95.07	422.95	436.01	1.4 %	ACCEPTABLE
46	-69.43	216.55	230.02	1.5 %	ACCEPTABLE
47	-0.92	3.24	9.62	58.8 %	ACCEPTABLE
48	0.99	2.82	9.38	47.7 %	ACCEPTABLE
49	-3.42	15.99	20.84	3.0 %	ACCEPTABLE
50	-0.84	9.64	14.46	2.9 %	ACCEPTABLE
51	-1.55	7.37	13.65	14.4 %	ACCEPTABLE
52	1.74	0.02	8.19	33.8 %	ACCEPTABLE
53	-1.20	5.77	12.55	51.4 %	ACCEPTABLE
54	0.88	3.24	9.62	49.3 %	ACCEPTABLE
55	-0.53	2.68	10.80	41.8 %	ACCEPTABLE
56	-0.34	0.34	6.69	12.4 %	ACCEPTABLE
57	-3.77	7.14	12.37	4.4 %	ACCEPTABLE
58	-1.85	4.64	9.41	3.9 %	ACCEPTABLE
59	-2.72	3.24	9.62	2.5 %	ACCEPTABLE
60	-2.12	1.00	8.52	48.3 %	ACCEPTABLE
61	-2.48	2.35	9.13	3.1 %	ACCEPTABLE
62	-0.35	0.37	6.70	10.4 %	ACCEPTABLE
63	-1.44	6.88	13.30	53.9 %	ACCEPTABLE
64	0.81	3.49	9.77	50.2 %	ACCEPTABLE
65	-75.84	245.88	259.25	1.0 %	ACCEPTABLE
66	-91.16	383.48	396.58	1.3 %	ACCEPTABLE
67	-74.04	245.88	259.25	1.5 %	ACCEPTABLE
68	-0.92	3.24	9.62	58.8 %	ACCEPTABLE
69	0.24	3.39	9.71	54.0 %	ACCEPTABLE
70	-2.31	10.05	15.38	1.7 %	ACCEPTABLE
71	-0.67	6.78	12.09	1.1 %	ACCEPTABLE
72	-1.35	5.94	12.23	11.2 %	ACCEPTABLE
73	0.87	1.05	8.54	42.7 %	ACCEPTABLE
74	-1.12	4.95	11.57	54.6 %	ACCEPTABLE
75	0.28	3.24	9.62	53.5 %	ACCEPTABLE
76	-0.63	2.82	10.36	46.9 %	ACCEPTABLE
77	-0.59	1.38	7.65	6.5 %	ACCEPTABLE
78	-2.79	5.71	11.28	1.6 %	ACCEPTABLE
79	-1.42	3.99	9.26	1.6 %	ACCEPTABLE
80	-2.12	3.24	9.62	2.6 %	ACCEPTABLE
81	-0.72	0.09	7.66	46.0 %	ACCEPTABLE
82	-1.77	1.95	8.93	54.3 %	ACCEPTABLE

No.	Center		Radius R [m]	Utilization	Verification
	x [m]	z [m]			
83	-0.41	0.81	7.39	56.0 %	ACCEPTABLE
84	-1.44	0.70	8.41	46.2 %	ACCEPTABLE
85	-1.98	2.71	9.32	4.1 %	ACCEPTABLE
86	-0.55	1.24	7.59	12.3 %	ACCEPTABLE
87	-1.27	5.58	11.99	56.2 %	ACCEPTABLE
88	0.21	3.49	9.77	54.4 %	ACCEPTABLE
89	-78.34	266.56	279.87	1.1 %	ACCEPTABLE
90	-88.56	358.29	371.43	1.3 %	ACCEPTABLE
91	-77.14	266.56	279.87	1.3 %	ACCEPTABLE
92	-0.92	3.24	9.62	58.8 %	ACCEPTABLE
93	-0.19	3.50	9.78	56.3 %	ACCEPTABLE
94	-1.76	7.25	12.92	1.2 %	ACCEPTABLE
95	-0.69	5.37	11.03	1.3 %	ACCEPTABLE
96	-1.22	5.01	11.32	15.6 %	ACCEPTABLE
97	0.28	1.76	8.84	48.4 %	ACCEPTABLE
98	-1.06	4.39	10.92	55.9 %	ACCEPTABLE
99	-0.12	3.24	9.62	55.4 %	ACCEPTABLE
100	-0.71	2.94	10.09	50.5 %	ACCEPTABLE
101	-0.72	2.02	8.31	7.9 %	ACCEPTABLE
102	-2.15	4.84	10.65	1.5 %	ACCEPTABLE
103	-1.22	3.68	9.31	1.1 %	ACCEPTABLE
104	-1.72	3.24	9.62	3.6 %	ACCEPTABLE
105	-0.76	0.98	8.16	50.5 %	ACCEPTABLE
106	-0.27	0.51	7.62	49.5 %	ACCEPTABLE
107	-1.52	2.48	9.19	24.3 %	ACCEPTABLE
108	-0.59	1.59	8.08	57.5 %	ACCEPTABLE
109	-1.24	1.45	8.70	50.9 %	ACCEPTABLE
110	-1.63	2.91	9.43	5.5 %	ACCEPTABLE
111	-0.67	1.87	8.23	16.4 %	ACCEPTABLE
112	-1.16	4.76	11.16	57.2 %	ACCEPTABLE
113	-0.17	3.44	9.74	56.1 %	ACCEPTABLE
114	-80.03	280.85	294.12	1.1 %	ACCEPTABLE
115	-86.84	342.00	355.16	1.3 %	ACCEPTABLE
116	-79.23	280.85	294.12	1.3 %	ACCEPTABLE
117	-0.92	3.24	9.62	58.8 %	ACCEPTABLE
118	-0.45	3.48	9.76	57.6 %	ACCEPTABLE
119	-1.45	5.72	11.63	1.9 %	ACCEPTABLE
120	-0.75	4.58	10.47	2.5 %	ACCEPTABLE
121	-1.12	4.41	10.74	17.0 %	ACCEPTABLE
122	-0.12	2.24	9.07	52.0 %	ACCEPTABLE
123	-1.02	4.01	10.49	56.9 %	ACCEPTABLE
124	-0.39	3.24	9.62	56.6 %	ACCEPTABLE
125	-0.77	3.03	9.92	52.9 %	ACCEPTABLE
126	-0.80	2.44	8.75	9.5 %	ACCEPTABLE
127	-1.74	4.29	10.28	2.0 %	ACCEPTABLE
128	-1.10	3.51	9.39	1.8 %	ACCEPTABLE
129	-1.45	3.24	9.62	5.6 %	ACCEPTABLE
130	-0.80	1.66	8.56	53.6 %	ACCEPTABLE
131	-0.47	1.32	8.18	53.2 %	ACCEPTABLE
132	-1.33	2.78	9.36	26.3 %	ACCEPTABLE
133	-0.70	2.12	8.58	58.1 %	ACCEPTABLE
134	-1.12	1.99	8.95	53.5 %	ACCEPTABLE

No.	Center		Radius R [m]	Utilization	Verification
	x [m]	z [m]			
135	-1.40	3.03	9.50	9.2 %	ACCEPTABLE
136	-0.76	2.31	8.67	16.3 %	ACCEPTABLE
137	-1.08	4.24	10.63	57.7 %	ACCEPTABLE
138	-0.43	3.39	9.71	57.1 %	ACCEPTABLE
139	-81.15	290.59	303.85	1.1 %	ACCEPTABLE
140	-85.70	331.36	344.54	1.2 %	ACCEPTABLE
141	-80.62	290.59	303.85	1.2 %	ACCEPTABLE
142	-0.92	3.24	9.62	58.8 %	ACCEPTABLE
143	-0.61	3.43	9.73	58.0 %	ACCEPTABLE
144	-1.26	4.82	10.88	3.1 %	ACCEPTABLE
145	-0.79	4.10	10.15	4.4 %	ACCEPTABLE
146	-1.06	4.01	10.36	26.4 %	ACCEPTABLE
147	-0.38	2.57	9.24	54.2 %	ACCEPTABLE
148	-0.99	3.76	10.20	57.5 %	ACCEPTABLE
149	-0.56	3.24	9.62	57.2 %	ACCEPTABLE
150	-0.82	3.09	9.81	54.8 %	ACCEPTABLE
151	-0.84	2.71	9.04	11.9 %	ACCEPTABLE
152	-1.46	3.93	10.05	2.7 %	ACCEPTABLE
153	-1.04	3.41	9.46	2.9 %	ACCEPTABLE
154	-1.28	3.24	9.62	7.6 %	ACCEPTABLE
155	-0.83	2.15	8.88	55.4 %	ACCEPTABLE
156	-0.61	1.91	8.61	55.1 %	ACCEPTABLE
157	-1.20	2.95	9.45	17.1 %	ACCEPTABLE
158	-0.78	2.49	8.91	58.4 %	ACCEPTABLE
159	-1.05	2.38	9.14	55.3 %	ACCEPTABLE
160	-1.24	3.11	9.54	10.0 %	ACCEPTABLE
161	-0.81	2.61	8.98	25.4 %	ACCEPTABLE
162	-1.03	3.90	10.29	58.5 %	ACCEPTABLE
163	-0.59	3.35	9.68	57.5 %	ACCEPTABLE
164	-81.91	297.19	310.43	1.2 %	ACCEPTABLE
165	-84.94	324.37	337.56	1.2 %	ACCEPTABLE
166	-81.55	297.19	310.43	1.2 %	ACCEPTABLE
167	-0.92	3.24	9.62	58.8 %	ACCEPTABLE
168	-0.72	3.38	9.70	58.2 %	ACCEPTABLE
169	-1.14	4.26	10.43	4.9 %	ACCEPTABLE
170	-0.83	3.80	9.96	6.6 %	ACCEPTABLE
171	-1.01	3.75	10.11	25.2 %	ACCEPTABLE
172	-0.56	2.79	9.36	55.4 %	ACCEPTABLE
173	-0.97	3.59	10.01	57.9 %	ACCEPTABLE
174	-0.68	3.24	9.62	57.5 %	ACCEPTABLE
175	-0.85	3.14	9.75	56.0 %	ACCEPTABLE
176	-0.87	2.89	9.23	12.8 %	ACCEPTABLE
177	-1.28	3.70	9.90	3.9 %	ACCEPTABLE
178	-1.00	3.35	9.51	4.4 %	ACCEPTABLE
179	-1.16	3.24	9.62	9.2 %	ACCEPTABLE
180	-0.86	2.49	9.11	56.4 %	ACCEPTABLE
181	-0.71	2.33	8.92	56.3 %	ACCEPTABLE
182	-1.11	3.06	9.51	25.0 %	ACCEPTABLE
183	-0.83	2.74	9.15	58.4 %	ACCEPTABLE
184	-1.00	2.65	9.29	56.5 %	ACCEPTABLE
185	-1.13	3.15	9.57	16.0 %	ACCEPTABLE
186	-0.85	2.82	9.19	17.3 %	ACCEPTABLE



No.	Center		Radius R [m]	Utilization	Verification
	x [m]	z [m]			
187	-0.99	3.68	10.06	58.4 %	ACCEPTABLE
188	-0.70	3.31	9.66	57.7 %	ACCEPTABLE
189	-82.41	301.63	314.86	1.2 %	ACCEPTABLE
190	-84.43	319.75	332.95	1.2 %	ACCEPTABLE
191	-82.17	301.63	314.86	1.2 %	ACCEPTABLE
192	-0.92	3.24	9.62	58.8 %	ACCEPTABLE
193	-0.79	3.34	9.68	58.3 %	ACCEPTABLE
194	-1.07	3.91	10.15	6.5 %	ACCEPTABLE
195	-0.86	3.61	9.84	9.4 %	ACCEPTABLE
196	-0.98	3.58	9.94	25.0 %	ACCEPTABLE
197	-0.68	2.94	9.45	56.4 %	ACCEPTABLE
198	-0.95	3.47	9.88	58.2 %	ACCEPTABLE
199	-0.76	3.24	9.62	57.8 %	ACCEPTABLE
200	-0.87	3.17	9.70	56.9 %	ACCEPTABLE
201	-0.89	3.01	9.36	17.2 %	ACCEPTABLE
202	-1.16	3.55	9.80	5.2 %	ACCEPTABLE
203	-0.97	3.31	9.54	5.9 %	ACCEPTABLE
204	-1.08	3.24	9.62	16.0 %	ACCEPTABLE
205	-0.88	2.73	9.27	57.3 %	ACCEPTABLE
206	-0.78	2.62	9.14	57.0 %	ACCEPTABLE
207	-1.05	3.12	9.55	25.1 %	ACCEPTABLE
208	-0.86	2.90	9.30	58.4 %	ACCEPTABLE
209	-0.97	2.84	9.39	57.3 %	ACCEPTABLE
210	-1.06	3.18	9.59	25.1 %	ACCEPTABLE
211	-0.87	2.96	9.33	26.6 %	ACCEPTABLE
212	-0.97	3.53	9.91	26.4 %	ACCEPTABLE
213	-0.78	3.29	9.65	58.3 %	ACCEPTABLE
214	-82.75	304.61	317.84	1.2 %	ACCEPTABLE
215	-84.09	316.69	329.89	1.2 %	ACCEPTABLE
216	-82.59	304.61	317.84	1.2 %	ACCEPTABLE
217	-0.92	3.24	9.62	58.8 %	ACCEPTABLE
218	-0.83	3.31	9.66	58.4 %	ACCEPTABLE
219	-1.02	3.68	9.96	9.3 %	ACCEPTABLE
220	-0.88	3.48	9.76	12.0 %	ACCEPTABLE
221	-0.96	3.47	9.84	26.4 %	ACCEPTABLE
222	-0.76	3.04	9.50	57.3 %	ACCEPTABLE
223	-0.94	3.39	9.79	58.4 %	ACCEPTABLE
224	-0.81	3.24	9.62	58.1 %	ACCEPTABLE
225	-0.89	3.19	9.67	57.6 %	ACCEPTABLE
226	-0.90	3.08	9.45	25.2 %	ACCEPTABLE
227	-1.08	3.44	9.74	8.0 %	ACCEPTABLE
228	-0.95	3.29	9.57	8.1 %	ACCEPTABLE
229	-1.03	3.24	9.62	17.1 %	ACCEPTABLE
230	-0.89	2.90	9.38	57.7 %	ACCEPTABLE
231	-0.83	2.82	9.30	57.5 %	ACCEPTABLE
232	-1.01	3.16	9.58	26.5 %	ACCEPTABLE
233	-0.88	3.01	9.41	58.3 %	ACCEPTABLE
234	-0.95	2.97	9.47	57.6 %	ACCEPTABLE
235	-1.02	3.20	9.60	16.0 %	ACCEPTABLE
236	-0.89	3.05	9.43	26.6 %	ACCEPTABLE
237	-0.95	3.43	9.81	58.6 %	ACCEPTABLE
238	-0.82	3.27	9.64	58.2 %	ACCEPTABLE

No.	Center		Radius R [m]	Utilization	Verification
	x [m]	z [m]			
239	-82.97	306.61	319.83	1.2 %	ACCEPTABLE
240	-83.87	314.66	327.87	1.2 %	ACCEPTABLE
241	-82.86	306.61	319.83	1.2 %	ACCEPTABLE
242	-0.92	3.24	9.62	58.8 %	ACCEPTABLE
243	-0.86	3.29	9.65	58.6 %	ACCEPTABLE
244	-0.98	3.53	9.85	12.1 %	ACCEPTABLE
245	-0.89	3.40	9.72	25.4 %	ACCEPTABLE
246	-0.95	3.39	9.76	26.5 %	ACCEPTABLE
247	-0.81	3.11	9.54	57.6 %	ACCEPTABLE
248	-0.93	3.34	9.73	58.6 %	ACCEPTABLE
249	-0.85	3.24	9.62	58.4 %	ACCEPTABLE
250	-0.90	3.21	9.66	57.9 %	ACCEPTABLE
251	-0.91	3.14	9.51	25.2 %	ACCEPTABLE
252	-1.03	3.38	9.70	12.0 %	ACCEPTABLE
253	-0.94	3.27	9.59	12.4 %	ACCEPTABLE
254	-0.99	3.24	9.62	25.1 %	ACCEPTABLE
255	-0.90	3.01	9.46	58.0 %	ACCEPTABLE
256	-0.86	2.96	9.40	57.9 %	ACCEPTABLE
257	-0.98	3.19	9.59	26.5 %	ACCEPTABLE
258	-0.89	3.09	9.48	25.1 %	ACCEPTABLE
259	-0.94	3.06	9.52	57.8 %	ACCEPTABLE
260	-0.98	3.22	9.61	25.1 %	ACCEPTABLE
261	-0.90	3.11	9.49	26.5 %	ACCEPTABLE
262	-0.94	3.37	9.75	58.6 %	ACCEPTABLE
263	-0.86	3.26	9.63	58.5 %	ACCEPTABLE
264	-83.12	307.94	321.16	1.2 %	ACCEPTABLE
265	-83.72	313.31	326.52	1.2 %	ACCEPTABLE
266	-83.05	307.94	321.16	1.2 %	ACCEPTABLE
267	-0.92	3.24	9.62	58.8 %	ACCEPTABLE
268	-0.88	3.27	9.64	58.5 %	ACCEPTABLE
269	-0.96	3.43	9.77	17.1 %	ACCEPTABLE
270	-0.90	3.35	9.68	17.2 %	ACCEPTABLE
271	-0.94	3.34	9.72	58.7 %	ACCEPTABLE
272	-0.85	3.15	9.57	58.0 %	ACCEPTABLE
273	-0.93	3.31	9.70	58.6 %	ACCEPTABLE
274	-0.87	3.24	9.62	58.4 %	ACCEPTABLE
275	-0.91	3.22	9.64	58.3 %	ACCEPTABLE
276	-0.91	3.17	9.54	26.5 %	ACCEPTABLE
277	-0.99	3.33	9.67	11.7 %	ACCEPTABLE
278	-0.93	3.26	9.60	17.2 %	ACCEPTABLE
279	-0.97	3.24	9.62	25.1 %	ACCEPTABLE
280	-0.91	3.09	9.51	58.4 %	ACCEPTABLE
281	-0.88	3.05	9.47	58.0 %	ACCEPTABLE
282	-0.96	3.21	9.60	26.5 %	ACCEPTABLE
283	-0.90	3.14	9.53	26.5 %	ACCEPTABLE
284	-0.93	3.12	9.55	58.2 %	ACCEPTABLE
285	-0.96	3.22	9.61	25.1 %	ACCEPTABLE
286	-0.91	3.16	9.53	26.5 %	ACCEPTABLE
287	-0.93	3.32	9.71	58.6 %	ACCEPTABLE
288	-0.88	3.26	9.63	58.5 %	ACCEPTABLE
289	-83.22	308.84	322.05	1.2 %	ACCEPTABLE
290	-83.62	312.42	325.62	1.2 %	ACCEPTABLE

No.	Center		Radius R [m]	Utilization	Verification
	x [m]	z [m]			
291	-83.17	308.84	322.05	1.2 %	ACCEPTABLE
292	-0.92	3.24	9.62	58.8 %	ACCEPTABLE
293	-0.89	3.26	9.63	58.5 %	ACCEPTABLE
294	-0.95	3.37	9.72	25.1 %	ACCEPTABLE
295	-0.91	3.31	9.66	25.1 %	ACCEPTABLE
296	-0.93	3.31	9.68	25.1 %	ACCEPTABLE
297	-0.87	3.18	9.58	58.2 %	ACCEPTABLE
298	-0.93	3.29	9.67	58.7 %	ACCEPTABLE
299	-0.89	3.24	9.62	58.4 %	ACCEPTABLE
300	-0.91	3.23	9.64	58.4 %	ACCEPTABLE
301	-0.91	3.19	9.57	26.5 %	ACCEPTABLE
302	-0.97	3.30	9.66	16.0 %	ACCEPTABLE
303	-0.93	3.25	9.60	16.0 %	ACCEPTABLE
304	-0.95	3.24	9.62	26.5 %	ACCEPTABLE
305	-0.91	3.14	9.55	58.5 %	ACCEPTABLE
306	-0.89	3.11	9.52	58.1 %	ACCEPTABLE
307	-0.95	3.22	9.61	25.1 %	ACCEPTABLE
308	-0.91	3.17	9.56	26.5 %	ACCEPTABLE
309	-0.93	3.16	9.57	58.4 %	ACCEPTABLE
310	-0.95	3.23	9.61	26.5 %	ACCEPTABLE
311	-0.91	3.18	9.56	26.5 %	ACCEPTABLE
312	-0.93	3.30	9.68	58.7 %	ACCEPTABLE
313	-0.89	3.25	9.63	58.4 %	ACCEPTABLE
314	-83.28	309.43	322.65	1.2 %	ACCEPTABLE
315	-83.55	311.82	325.03	1.2 %	ACCEPTABLE
316	-83.25	309.43	322.65	1.2 %	ACCEPTABLE
317	-0.92	3.24	9.62	58.8 %	ACCEPTABLE
318	-0.90	3.25	9.63	58.4 %	ACCEPTABLE
319	-0.94	3.32	9.69	26.5 %	ACCEPTABLE
320	-0.91	3.29	9.65	25.1 %	ACCEPTABLE
321	-0.93	3.28	9.66	58.7 %	ACCEPTABLE
322	-0.89	3.20	9.60	58.2 %	ACCEPTABLE
323	-0.92	3.27	9.65	58.4 %	ACCEPTABLE
324	-0.90	3.24	9.62	58.4 %	ACCEPTABLE
325	-0.91	3.23	9.63	58.5 %	ACCEPTABLE
326	-0.92	3.21	9.59	26.5 %	ACCEPTABLE
327	-0.95	3.28	9.64	16.0 %	ACCEPTABLE
328	-0.93	3.25	9.61	25.2 %	ACCEPTABLE
329	-0.94	3.24	9.62	26.5 %	ACCEPTABLE
330	-0.91	3.17	9.57	58.5 %	ACCEPTABLE
331	-0.90	3.16	9.55	58.3 %	ACCEPTABLE
332	-0.94	3.23	9.61	26.5 %	ACCEPTABLE
333	-0.91	3.20	9.58	58.4 %	ACCEPTABLE
334	-0.93	3.19	9.59	58.5 %	ACCEPTABLE
335	-0.94	3.23	9.62	25.1 %	ACCEPTABLE
336	-0.91	3.20	9.58	58.4 %	ACCEPTABLE
337	-0.93	3.28	9.66	58.7 %	ACCEPTABLE
338	-0.90	3.25	9.62	58.5 %	ACCEPTABLE
339	-83.33	309.83	323.04	1.2 %	ACCEPTABLE
340	-83.51	311.42	324.63	1.2 %	ACCEPTABLE
341	-83.31	309.83	323.04	1.2 %	ACCEPTABLE
342	-0.92	3.24	9.62	58.8 %	ACCEPTABLE

Input data (Stage of construction 2)

Geological profile and assigned soils

No.	Layer [m]	Assigned soil	Pattern
1	5.20	Mbushje	
2	4.80	Shtresa 3.Perfaqesohet nga depozitime magmatike, ultrabazike, dunitë.Takohen nga sipërfaqja mbas thellesise 4 - 5 m	
3	-	Shtresa 3.Perfaqesohet nga depozitime magmatike, ultrabazike, dunitë.Takohen nga sipërfaqja mbas thellesise 4 - 5 m	

Foundation

Type of foundation : soil from geological profile

Terrain profile

Terrain behind the structure is flat.

Water influence

Ground water table is located below the structure.

Input surface surcharges

No.	Surcharge		Action	Mag.1 [kN/m ²]	Mag.2 [kN/m ²]	Ord.x x [m]	Length l [m]	Depth z [m]
	new	change						
1	NO	NO	variable	4.00		2.00	7.50	on terrain

No.	Name
1	Ngarkesa e Trafikut

Resistance on front face of the structure

Resistance on front face of the structure: at rest

Soil on front face of the structure - Mbushje

Soil thickness in front of structure $h = 1.50$ m

Terrain in front of structure is flat.

Earthquake

Factor of horizontal acceleration $K_h = 0.2040$

Factor of vertical acceleration $K_v = 0.1020$

Water below the GWT is restricted.

Settings of the stage of construction

Design situation : seismic

The wall is free to move. Active earth pressure is therefore assumed.

Verification No. 1 (Stage of construction 2)

Forces acting on construction

Name	F_{hor} [kN/m]	App.Pt. z [m]	F_{vert} [kN/m]	App.Pt. x [m]	Coeff. overturn.	Coeff. sliding	Coeff. stress
Weight - wall	0.00	-1.54	114.97	1.45	1.000	1.000	1.000
Earthq.- constr.	23.45	-1.54	-11.73	1.45	1.000	1.000	1.000

Name	F_{hor} [kN/m]	App.Pt. z [m]	F_{vert} [kN/m]	App.Pt. x [m]	Coeff. overtur.	Coeff. sliding	Coeff. stress
FF resistance	-9.11	-0.50	0.02	0.35	1.000	1.000	1.000
Weight - earth wedge	0.00	-2.43	137.33	2.07	1.000	1.000	1.000
Earthquake - soil wedge	28.01	-2.43	-14.01	2.07	1.000	1.000	1.000
Active pressure	79.90	-1.88	128.48	3.06	1.000	1.000	1.000
Earthq.- act.pressure	53.11	-3.71	101.07	2.26	1.000	1.000	1.000
Ngarkesa e Trafikut	2.28	-1.95	3.45	2.95	0.700	0.700	0.700

Verification of complete wall

Check for overturning stability

Resisting moment $M_{res} = 1034.35$ kNm/m

Overturning moment $M_{ovr} = 450.12$ kNm/m

Wall for overturning is SATISFACTORY

Check for slip

Resisting horizontal force $H_{res} = 286.53$ kN/m

Active horizontal force $H_{act} = 176.97$ kN/m

Wall for slip is SATISFACTORY

Overall check - WALL is SATISFACTORY

Maximum stress in footing bottom : 179.95 kPa

Bearing capacity of foundation soil (Stage of construction 2)

Design load acting at the center of footing bottom

No.	Moment [kNm/m]	Norm. force [kN/m]	Shear Force [kN/m]	Eccentricity [-]	Stress [kPa]
1	309.68	458.55	176.97	0.173	179.95

Service load acting at the center of footing bottom

No.	Moment [kNm/m]	Norm. force [kN/m]	Shear Force [kN/m]
1	309.68	458.55	176.97

Verification of foundation soil

Eccentricity verification

Max. eccentricity of normal force $e = 0.173$

Maximum allowable eccentricity $e_{alw} = 0.333$

Eccentricity of the normal force is SATISFACTORY

Verification of bearing capacity

Max. stress at footing bottom $\sigma = 179.95$ kPa

Bearing capacity of foundation soil $R_d = 392.00$ kPa

Bearing capacity of foundation soil is SATISFACTORY

Overall verification - bearing capacity of found. soil is SATISFACTORY

Dimensioning No. 1 (Stage of construction 2)

Forces acting on construction

Name	F_{hor} [kN/m]	App.Pt. z [m]	F_{vert} [kN/m]	App.Pt. x [m]	Design coefficient
Weight - wall	0.00	-0.30	39.00	2.60	1.000
Weight - earth wedge	0.00	-2.43	137.33	2.07	1.000
Active pressure	79.90	-1.88	128.48	3.06	1.000
Ngarkesa e Trafikut	2.28	-1.95	3.45	2.95	0.700
Contact stress	0.00	0.00	-199.85	2.14	1.000

Back wall jump check

Reinforcement and dimensions of the cross-section

Bar diameter = 16.0 mm

Number of bars = 7

Reinforcement cover = 50.0 mm

Cross-section width = 1.00 m

Cross-section depth = 0.60 m

Reinforcement ratio $\rho = 0.26\% > 0.14\% = \rho_{min}$

Position of neutral axis $x = 0.05\text{ m} < 0.33\text{ m} = x_{max}$

Ultimate shear force $V_{Rd} = 195.03\text{ kN} > 107.38\text{ kN} = V_{Ed}$

Ultimate moment $M_{Rd} = 320.43\text{ kNm} > 218.91\text{ kNm} = M_{Ed}$

Cross-section is SATISFACTORY.

Slope stability analysis

Input data

Project

Settings

(input for current task)

Stability analysis

Earthquake analysis : Standard

Verification methodology : according to EN 1997

Design approach : 3 - reduction of actions (GEO, STR) and soil parameters

Partial factors on actions (A)					
Seismic design situation					
		State STR		State GEO	
		Unfavourable	Favourable	Unfavourable	Favourable
Permanent actions :	$\gamma_G =$	1.00 [-]	1.00 [-]	1.00 [-]	1.00 [-]
Variable actions :	$\gamma_Q =$	1.00 [-]	0.00 [-]	1.00 [-]	0.00 [-]
Water load :	$\gamma_w =$			1.00 [-]	

Partial factors for soil parameters (M)			
Seismic design situation			
Partial factor on internal friction :		$\gamma_\phi =$	1.00 [-]
Partial factor on effective cohesion :		$\gamma_c =$	1.00 [-]
Partial factor on undrained shear strength :		$\gamma_{cu} =$	1.00 [-]

Interface

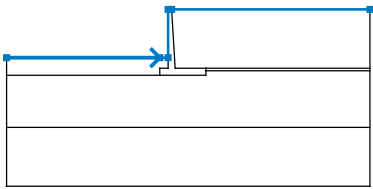
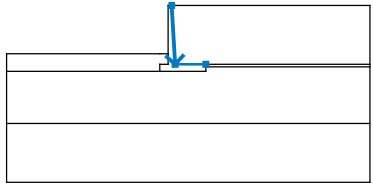
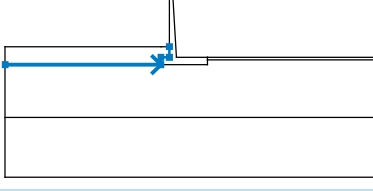
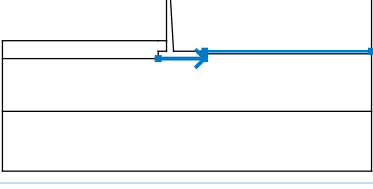
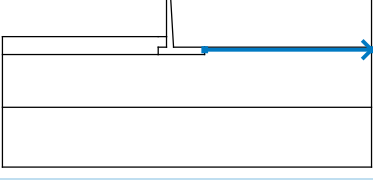
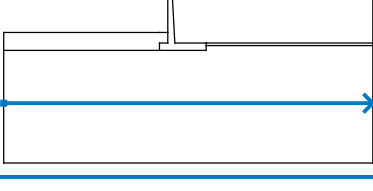

No.	Interface location	Coordinates of interface points [m]					
		x	z	x	z	x	z
1		-14.00	-4.10	-1.00	-4.10	-0.30	-4.10
		-0.30	0.00	0.00	0.00	16.80	0.00
2		0.00	0.00	0.29	-5.00	2.89	-5.00
3		-14.00	-5.60	-1.00	-5.60	-1.00	-5.00
		-0.30	-5.00	-0.30	-4.10		
4		-1.00	-5.60	2.89	-5.60	2.89	-5.20
		2.89	-5.00	16.80	-5.00		
5		2.89	-5.20	16.80	-5.20		
6		-14.00	-10.00	16.80	-10.00		

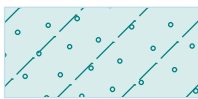
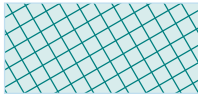
Soil parameters - effective stress state

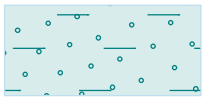
No.	Name	Pattern	Φ_{ef} [°]	C_{ef} [kPa]	γ [kN/m ³]
1	Shtresa 3. Perfaqesohet nga depozitime magmatike, ultrabazike, dunite. Takohen nga sipërfaqja mbas thellesise 4 - 5 m		32.00	0.00	24.81
2	Mbushje		35.00	0.00	19.00

No.	Name	Pattern	φ_{ef} [°]	c_{ef} [kPa]	γ [kN/m ³]
3	Shtresa 2 Perfaqesohet nga argjila e surera te perziera me brekcie dhe zaje te rrumbullakosura , ngjyre kafe. Jane pak te ngjeshura.		35.00	14.70	18.37

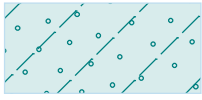
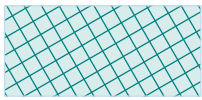
Soil parameters - uplift

No.	Name	Pattern	γ_{sat} [kN/m ³]	γ_s [kN/m ³]	n [-]
1	Shtresa 3.Perfaqesohet nga depozitime magmatike, ultrabazike, dunitë.Takohen nga siperfaqja mbas thellesise 4 - 5 m			24.81	0.00
2	Mbushje		20.00		
3	Shtresa 2 Perfaqesohet nga argjila e surera te perziera me brekcie dhe zaje te rrumbullakosura , ngjyre kafe. Jane pak te ngjeshura.		21.13		

Soil parameters

Shtresa 3.Perfaqesohet nga depozitime magmatike, ultrabazike, dunitë.Takohen nga siperfaqja mbas thellesise 4 - 5 m

Unit weight : $\gamma = 24.81$ kN/m³
 Stress-state : effective
 Angle of internal friction : $\varphi_{ef} = 32.00$ °
 Cohesion of soil : $c_{ef} = 0.00$ kPa
 Solid unit weight : $\gamma_s = 24.81$ kN/m³
 Porosity <0.0 - 1.0> : $n = 0.00$

Mbushje

Unit weight : $\gamma = 19.00$ kN/m³
 Stress-state : effective
 Angle of internal friction : $\varphi_{ef} = 35.00$ °
 Cohesion of soil : $c_{ef} = 0.00$ kPa
 Saturated unit weight : $\gamma_{sat} = 20.00$ kN/m³

Shtresa 2 Perfaqesohet nga argjila e surera te perziera me brekcie dhe zaje te rrumbullakosura , ngjyre kafe. Jane pak te ngjeshura.

Unit weight : $\gamma = 18.37$ kN/m³
 Stress-state : effective
 Angle of internal friction : $\varphi_{ef} = 35.00$ °
 Cohesion of soil : $c_{ef} = 14.70$ kPa
 Saturated unit weight : $\gamma_{sat} = 21.13$ kN/m³

Rigid bodies

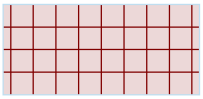
No.	Name	Sample	γ [kN/m ³]
1	Wall material		25.00

Assigning and surfaces

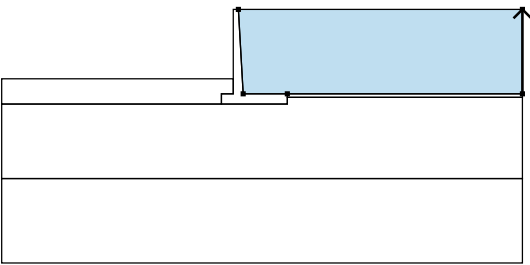
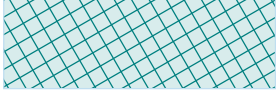
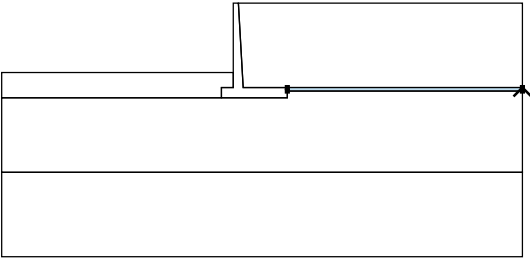
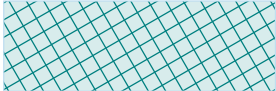
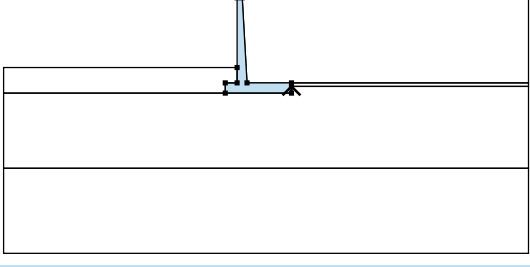
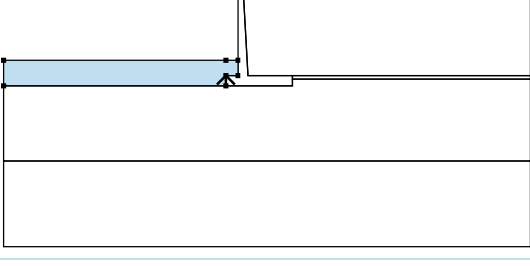
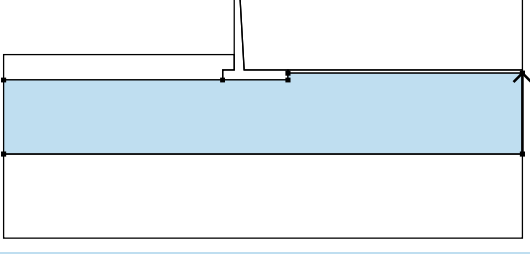
No.	Surface position	Coordinates of surface points [m]				Assigned soil
		x	z	x	z	
1		16.80	-5.00	16.80	0.00	Mbushje
		0.00	0.00	0.29	-5.00	
		2.89	-5.00			
2		16.80	-5.20	16.80	-5.00	Mbushje
		2.89	-5.00	2.89	-5.20	
						
3		2.89	-5.60	2.89	-5.20	Wall material
		2.89	-5.00	0.29	-5.00	
		0.00	0.00	-0.30	0.00	
		-0.30	-4.10	-0.30	-5.00	
		-1.00	-5.00	-1.00	-5.60	
4		-1.00	-5.60	-1.00	-5.00	Mbushje
		-0.30	-5.00	-0.30	-4.10	
		-1.00	-4.10	-14.00	-4.10	
		-14.00	-5.60			
5		16.80	-10.00	16.80	-5.20	Shtresa 3.Perfaqesohet nga depozitime magmatike,
		2.89	-5.20	2.89	-5.60	
		-1.00	-5.60	-14.00	-5.60	
		-14.00	-10.00			

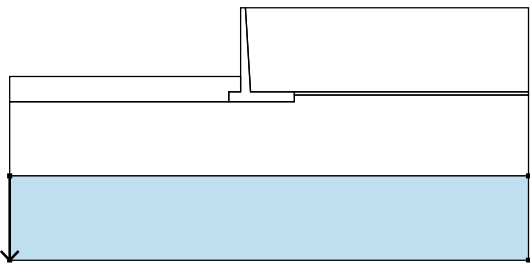
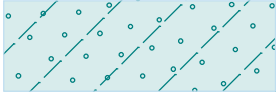
No.	Surface position	Coordinates of surface points [m]				Assigned soil
		x	z	x	z	
6		-14.00	-10.00	-14.00	-15.00	Shtresa 3.Perfaqesohet nga depozitime magmatike, 
		16.80	-15.00	16.80	-10.00	

Surcharge

No.	Type	Type of action	Location z [m]	Origin x [m]	Length l [m]	Width b [m]	Slope α [°]	Magnitude		
								q, q ₁ , f, F	q ₂	unit
1	strip	variable	on terrain	x = 2.00	l = 7.50		0.00	4.00		kN/m ²

Surcharges

No.	Name
1	Ngarkesa e Trafikut

Water

Water type : No water

Tensile crack

Tensile crack not inputted.

Earthquake

Horizontal seismic coefficient : $K_h = 0.20$

Vertical seismic coefficient : $K_v = 0.10$

Settings of the stage of construction

Design situation : seismic

Results (Stage of construction 1)

Analysis 1

Circular slip surface

Slip surface parameters						
Center :	x =	-1.32	[m]	Angles :	$\alpha_1 =$	-34.05 [°]
	z =	6.63	[m]		$\alpha_2 =$	59.20 [°]
Radius :	R =	12.95	[m]			
The slip surface after optimization.						

Slope stability verification (Bishop)

Sum of active forces : $F_a = 413.57$ kN/m

Sum of passive forces : $F_p = 640.10$ kN/m

Sliding moment : $M_a = 5355.71$ kNm/m

Resisting moment : $M_p = 8289.24$ kNm/m

Utilization : 64.6 %

Slope stability ACCEPTABLE

Optimization of circular slip surface (Bishop)

No.	Center		Radius R [m]	Utilization	Verification
	x [m]	z [m]			
1	-1.32	6.63	12.95	64.6 %	ACCEPTABLE

No.	Center		Radius R [m]	Utilization	Verification
	x [m]	z [m]			
2	-1.32	6.63	12.95	64.6 %	ACCEPTABLE
3	-1.32	6.63	12.95	64.6 %	ACCEPTABLE
4	-1.43	15.84	23.46	54.4 %	ACCEPTABLE
5	4.76	6.63	12.95	2.3 %	ACCEPTABLE
6	0.22	3.87	16.13	35.2 %	ACCEPTABLE
7	-6.89	5.87	12.13	3.4 %	ACCEPTABLE
8	-5.72	0.89	9.49	4.9 %	ACCEPTABLE
9	5.30	4.21	11.39	5.2 %	ACCEPTABLE
10	-72.42	207.86	221.37	0.7 %	ACCEPTABLE
11	-125.19	766.45	779.32	3.0 %	ACCEPTABLE
12	-66.34	207.86	221.37	3.0 %	ACCEPTABLE
13	-1.32	6.63	12.95	64.6 %	ACCEPTABLE
14	-134.53	621.81	639.27	3.3 %	ACCEPTABLE
15	-2.62	18.84	25.03	23.4 %	ACCEPTABLE
16	-1.76	13.32	20.53	57.1 %	ACCEPTABLE
17	2.73	6.63	12.95	50.7 %	ACCEPTABLE
18	-0.45	4.84	15.10	41.5 %	ACCEPTABLE
19	-11.69	34.95	39.06	1.7 %	ACCEPTABLE
20	-85.29	213.09	231.72	1.7 %	ACCEPTABLE
21	-5.37	6.63	12.95	2.1 %	ACCEPTABLE
22	-4.66	3.44	10.96	3.8 %	ACCEPTABLE
23	-2.43	17.65	24.02	60.9 %	ACCEPTABLE
24	2.76	6.52	12.87	50.5 %	ACCEPTABLE
25	-80.81	275.29	288.57	1.2 %	ACCEPTABLE
26	-116.13	647.68	660.59	3.0 %	ACCEPTABLE
27	-76.75	275.29	288.57	2.7 %	ACCEPTABLE
28	-1.32	6.63	12.95	64.6 %	ACCEPTABLE
29	1.70	5.21	12.00	52.5 %	ACCEPTABLE
30	-8.08	48.42	52.61	3.8 %	ACCEPTABLE
31	-3.47	28.39	32.58	4.4 %	ACCEPTABLE
32	-2.24	14.52	20.70	10.8 %	ACCEPTABLE
33	2.70	0.74	9.84	35.3 %	ACCEPTABLE
34	-1.66	11.16	18.03	59.4 %	ACCEPTABLE
35	1.38	6.63	12.95	56.2 %	ACCEPTABLE
36	-0.63	5.20	14.13	46.9 %	ACCEPTABLE
37	-0.44	1.31	7.66	26.3 %	ACCEPTABLE
38	-6.45	17.53	22.16	2.9 %	ACCEPTABLE
39	-4.30	13.50	17.67	2.9 %	ACCEPTABLE
40	-4.02	6.63	12.95	2.2 %	ACCEPTABLE
41	-2.97	1.93	10.26	49.0 %	ACCEPTABLE
42	-0.08	0.15	7.18	51.2 %	ACCEPTABLE
43	-3.60	4.75	11.71	3.4 %	ACCEPTABLE
44	-0.50	1.50	7.75	7.4 %	ACCEPTABLE
45	-2.07	13.53	19.89	62.3 %	ACCEPTABLE
46	1.28	7.08	13.27	57.2 %	ACCEPTABLE
47	-86.54	325.94	339.13	1.5 %	ACCEPTABLE
48	-110.13	574.20	587.15	2.5 %	ACCEPTABLE
49	-83.84	325.94	339.13	2.4 %	ACCEPTABLE
50	-1.32	6.63	12.95	64.6 %	ACCEPTABLE
51	0.45	6.78	13.05	59.5 %	ACCEPTABLE
52	-4.18	23.69	28.47	5.3 %	ACCEPTABLE
53	-1.58	15.86	20.63	5.0 %	ACCEPTABLE

No.	Center		Radius R [m]	Utilization	Verification
	x [m]	z [m]			
54	-1.96	11.77	17.96	11.0 %	ACCEPTABLE
55	1.40	2.50	10.50	45.2 %	ACCEPTABLE
56	-1.57	9.69	16.36	61.1 %	ACCEPTABLE
57	0.48	6.63	12.95	59.1 %	ACCEPTABLE
58	-0.80	5.53	13.58	51.6 %	ACCEPTABLE
59	-0.86	3.26	9.44	5.9 %	ACCEPTABLE
60	-4.46	12.62	17.74	4.3 %	ACCEPTABLE
61	-2.57	9.44	14.17	3.8 %	ACCEPTABLE
62	-3.12	6.63	12.95	2.4 %	ACCEPTABLE
63	-1.03	0.95	9.08	47.8 %	ACCEPTABLE
64	-2.51	3.90	11.21	58.3 %	ACCEPTABLE
65	-0.54	2.11	8.80	59.3 %	ACCEPTABLE
66	-2.07	1.92	10.25	49.0 %	ACCEPTABLE
67	-2.87	5.50	12.18	4.8 %	ACCEPTABLE
68	-0.79	3.01	9.29	12.3 %	ACCEPTABLE
69	-1.82	11.04	17.38	63.2 %	ACCEPTABLE
70	0.37	7.13	13.31	60.2 %	ACCEPTABLE
71	-90.41	362.25	375.38	1.7 %	ACCEPTABLE
72	-106.14	527.75	540.73	2.5 %	ACCEPTABLE
73	-88.61	362.25	375.38	2.2 %	ACCEPTABLE
74	-1.32	6.63	12.95	64.6 %	ACCEPTABLE
75	-0.23	7.12	13.30	62.1 %	ACCEPTABLE
76	-2.88	15.66	20.93	2.3 %	ACCEPTABLE
77	-1.24	11.64	16.90	1.3 %	ACCEPTABLE
78	-1.76	10.00	16.21	11.2 %	ACCEPTABLE
79	0.52	3.76	11.14	51.9 %	ACCEPTABLE
80	-1.50	8.69	15.23	62.2 %	ACCEPTABLE
81	-0.12	6.63	12.95	61.0 %	ACCEPTABLE
82	-0.94	5.81	13.28	55.2 %	ACCEPTABLE
83	-1.05	4.44	10.62	5.7 %	ACCEPTABLE
84	-3.33	10.27	15.74	2.0 %	ACCEPTABLE
85	-1.99	8.12	13.35	2.1 %	ACCEPTABLE
86	-2.52	6.63	12.95	3.0 %	ACCEPTABLE
87	-1.06	2.45	9.97	53.9 %	ACCEPTABLE
88	-0.34	1.67	9.10	52.5 %	ACCEPTABLE
89	-2.16	5.01	11.87	62.0 %	ACCEPTABLE
90	-0.82	3.54	10.06	62.5 %	ACCEPTABLE
91	-1.76	3.21	10.85	54.6 %	ACCEPTABLE
92	-2.37	5.94	12.47	6.2 %	ACCEPTABLE
93	-0.97	4.13	10.43	18.2 %	ACCEPTABLE
94	-1.66	9.48	15.82	63.6 %	ACCEPTABLE
95	-0.21	7.05	13.25	62.0 %	ACCEPTABLE
96	-93.00	387.58	400.68	1.9 %	ACCEPTABLE
97	-103.50	497.92	510.91	2.4 %	ACCEPTABLE
98	-91.80	387.58	400.68	2.3 %	ACCEPTABLE
99	-1.32	6.63	12.95	64.6 %	ACCEPTABLE
100	-0.63	7.11	13.29	63.3 %	ACCEPTABLE
101	-2.25	11.93	17.54	1.1 %	ACCEPTABLE
102	-1.19	9.62	15.22	0.9 %	ACCEPTABLE
103	-1.62	8.85	15.09	15.7 %	ACCEPTABLE
104	-0.08	4.66	11.66	56.2 %	ACCEPTABLE
105	-1.45	8.01	14.47	63.0 %	ACCEPTABLE

No.	Center		Radius R [m]	Utilization	Verification
	x [m]	z [m]			
106	-0.52	6.63	12.95	62.1 %	ACCEPTABLE
107	-1.04	6.04	13.12	58.0 %	ACCEPTABLE
108	-1.15	5.19	11.41	9.3 %	ACCEPTABLE
109	-2.63	8.93	14.67	1.3 %	ACCEPTABLE
110	-1.72	7.50	13.08	1.0 %	ACCEPTABLE
111	-2.12	6.63	12.95	4.6 %	ACCEPTABLE
112	-1.11	3.63	10.74	58.0 %	ACCEPTABLE
113	-0.63	3.05	10.11	57.2 %	ACCEPTABLE
114	-1.90	5.65	12.28	63.7 %	ACCEPTABLE
115	-0.99	4.53	10.98	62.7 %	ACCEPTABLE
116	-1.58	4.19	11.38	58.4 %	ACCEPTABLE
117	-2.02	6.20	12.65	9.3 %	ACCEPTABLE
118	-1.09	4.92	11.23	27.6 %	ACCEPTABLE
119	-1.55	8.49	14.82	64.0 %	ACCEPTABLE
120	-0.59	6.94	13.17	62.9 %	ACCEPTABLE
121	-94.74	404.97	418.04	1.9 %	ACCEPTABLE
122	-101.74	478.53	491.54	2.2 %	ACCEPTABLE
123	-93.94	404.97	418.04	2.0 %	ACCEPTABLE
124	-1.32	6.63	12.95	64.6 %	ACCEPTABLE
125	-0.87	7.02	13.22	63.8 %	ACCEPTABLE
126	-1.90	9.90	15.74	1.8 %	ACCEPTABLE
127	-1.20	8.49	14.33	2.3 %	ACCEPTABLE
128	-1.52	8.10	14.36	25.5 %	ACCEPTABLE
129	-0.49	5.29	12.05	58.9 %	ACCEPTABLE
130	-1.41	7.56	13.97	63.5 %	ACCEPTABLE
131	-0.79	6.63	12.95	62.7 %	ACCEPTABLE
132	-1.13	6.22	13.04	60.1 %	ACCEPTABLE
133	-1.21	5.68	11.92	11.8 %	ACCEPTABLE
134	-2.19	8.12	14.04	1.7 %	ACCEPTABLE
135	-1.57	7.17	12.99	1.6 %	ACCEPTABLE
136	-1.85	6.63	12.95	6.5 %	ACCEPTABLE
137	-1.16	4.52	11.37	59.7 %	ACCEPTABLE
138	-0.84	4.11	10.92	59.2 %	ACCEPTABLE
139	-1.72	6.03	12.53	64.4 %	ACCEPTABLE
140	-1.11	5.22	11.61	63.4 %	ACCEPTABLE
141	-1.47	4.92	11.82	60.7 %	ACCEPTABLE
142	-1.79	6.35	12.76	12.3 %	ACCEPTABLE
143	-1.17	5.48	11.79	26.0 %	ACCEPTABLE
144	-1.47	7.85	14.18	64.1 %	ACCEPTABLE
145	-0.84	6.85	13.11	63.3 %	ACCEPTABLE
146	-95.90	416.78	429.85	1.9 %	ACCEPTABLE
147	-100.57	465.82	478.84	2.2 %	ACCEPTABLE
148	-95.37	416.78	429.85	2.2 %	ACCEPTABLE
149	-1.32	6.63	12.95	64.6 %	ACCEPTABLE
150	-1.03	6.91	13.15	63.9 %	ACCEPTABLE
151	-1.69	8.71	14.71	3.0 %	ACCEPTABLE
152	-1.23	7.82	13.82	4.3 %	ACCEPTABLE
153	-1.46	7.60	13.88	25.7 %	ACCEPTABLE
154	-0.76	5.72	12.33	60.7 %	ACCEPTABLE
155	-1.38	7.25	13.63	63.6 %	ACCEPTABLE
156	-0.96	6.63	12.95	63.2 %	ACCEPTABLE
157	-1.19	6.34	13.00	61.3 %	ACCEPTABLE

No.	Center		Radius R [m]	Utilization	Verification
	x [m]	z [m]			
158	-1.25	6.00	12.27	17.4 %	ACCEPTABLE
159	-1.89	7.60	13.65	2.6 %	ACCEPTABLE
160	-1.48	6.97	12.96	2.8 %	ACCEPTABLE
161	-1.68	6.63	12.95	9.1 %	ACCEPTABLE
162	-1.20	5.17	11.84	61.4 %	ACCEPTABLE
163	-0.99	4.88	11.53	61.2 %	ACCEPTABLE
164	-1.59	6.25	12.69	63.7 %	ACCEPTABLE
165	-1.18	5.68	12.05	63.9 %	ACCEPTABLE
166	-1.41	5.45	12.15	61.4 %	ACCEPTABLE
167	-1.64	6.45	12.82	12.6 %	ACCEPTABLE
168	-1.22	5.85	12.17	26.0 %	ACCEPTABLE
169	-1.42	7.44	13.76	64.1 %	ACCEPTABLE
170	-1.00	6.78	13.06	63.6 %	ACCEPTABLE
171	-96.68	424.76	437.81	1.9 %	ACCEPTABLE
172	-99.79	457.45	470.48	2.2 %	ACCEPTABLE
173	-96.32	424.76	437.81	2.2 %	ACCEPTABLE
174	-1.32	6.63	12.95	64.6 %	ACCEPTABLE
175	-1.13	6.83	13.09	64.1 %	ACCEPTABLE
176	-1.56	7.97	14.08	4.8 %	ACCEPTABLE
177	-1.26	7.40	13.51	7.4 %	ACCEPTABLE
178	-1.41	7.28	13.57	25.7 %	ACCEPTABLE
179	-0.95	6.02	12.53	61.8 %	ACCEPTABLE
180	-1.36	7.04	13.40	63.9 %	ACCEPTABLE
181	-1.08	6.63	12.95	63.5 %	ACCEPTABLE
182	-1.23	6.43	12.98	62.2 %	ACCEPTABLE
183	-1.28	6.21	12.49	16.2 %	ACCEPTABLE
184	-1.70	7.27	13.41	4.2 %	ACCEPTABLE
185	-1.42	6.85	12.95	4.6 %	ACCEPTABLE
186	-1.56	6.63	12.95	16.0 %	ACCEPTABLE
187	-1.24	5.63	12.18	62.3 %	ACCEPTABLE
188	-1.10	5.43	11.97	62.3 %	ACCEPTABLE
189	-1.50	6.39	12.78	64.1 %	ACCEPTABLE
190	-1.23	6.00	12.35	64.1 %	ACCEPTABLE
191	-1.38	5.83	12.40	62.5 %	ACCEPTABLE
192	-1.53	6.51	12.87	27.3 %	ACCEPTABLE
193	-1.25	6.11	12.42	64.5 %	ACCEPTABLE
194	-1.39	7.17	13.49	64.2 %	ACCEPTABLE
195	-1.11	6.74	13.02	63.8 %	ACCEPTABLE
196	-97.19	430.12	443.17	1.9 %	ACCEPTABLE
197	-99.27	451.91	464.94	2.1 %	ACCEPTABLE
198	-96.96	430.12	443.17	2.2 %	ACCEPTABLE
199	-1.32	6.63	12.95	64.6 %	ACCEPTABLE
200	-1.19	6.77	13.05	64.1 %	ACCEPTABLE
201	-1.48	7.51	13.68	7.4 %	ACCEPTABLE
202	-1.28	7.14	13.31	9.8 %	ACCEPTABLE
203	-1.38	7.06	13.36	64.4 %	ACCEPTABLE
204	-1.07	6.22	12.66	62.7 %	ACCEPTABLE
205	-1.35	6.91	13.25	64.0 %	ACCEPTABLE
206	-1.16	6.63	12.95	63.8 %	ACCEPTABLE
207	-1.26	6.50	12.97	63.0 %	ACCEPTABLE
208	-1.29	6.35	12.65	25.9 %	ACCEPTABLE
209	-1.57	7.05	13.25	7.4 %	ACCEPTABLE

No.	Center		Radius R [m]	Utilization	Verification
	x [m]	z [m]			
210	-1.39	6.77	12.95	7.5 %	ACCEPTABLE
211	-1.48	6.63	12.95	16.1 %	ACCEPTABLE
212	-1.26	5.95	12.43	63.0 %	ACCEPTABLE
213	-1.17	5.82	12.28	63.1 %	ACCEPTABLE
214	-1.44	6.47	12.84	64.1 %	ACCEPTABLE
215	-1.26	6.21	12.55	64.2 %	ACCEPTABLE
216	-1.36	6.08	12.57	63.1 %	ACCEPTABLE
217	-1.46	6.55	12.90	25.8 %	ACCEPTABLE
218	-1.27	6.28	12.60	64.3 %	ACCEPTABLE
219	-1.37	6.99	13.31	64.2 %	ACCEPTABLE
220	-1.18	6.70	13.00	63.9 %	ACCEPTABLE
221	-97.54	433.71	446.76	1.9 %	ACCEPTABLE
222	-98.92	448.24	461.28	2.2 %	ACCEPTABLE
223	-97.38	433.71	446.76	2.1 %	ACCEPTABLE
224	-1.32	6.63	12.95	64.6 %	ACCEPTABLE
225	-1.24	6.72	13.02	64.2 %	ACCEPTABLE
226	-1.43	7.21	13.43	9.1 %	ACCEPTABLE
227	-1.29	6.96	13.19	17.2 %	ACCEPTABLE
228	-1.36	6.92	13.22	64.4 %	ACCEPTABLE
229	-1.15	6.35	12.76	63.2 %	ACCEPTABLE
230	-1.34	6.81	13.15	64.1 %	ACCEPTABLE
231	-1.21	6.63	12.95	64.0 %	ACCEPTABLE
232	-1.28	6.54	12.96	63.4 %	ACCEPTABLE
233	-1.30	6.44	12.75	64.4 %	ACCEPTABLE
234	-1.49	6.91	13.15	9.1 %	ACCEPTABLE
235	-1.36	6.72	12.95	9.9 %	ACCEPTABLE
236	-1.43	6.63	12.95	25.8 %	ACCEPTABLE
237	-1.28	6.17	12.60	63.5 %	ACCEPTABLE
238	-1.22	6.08	12.50	63.4 %	ACCEPTABLE
239	-1.40	6.53	12.88	64.2 %	ACCEPTABLE
240	-1.28	6.35	12.68	64.2 %	ACCEPTABLE
241	-1.34	6.26	12.69	63.5 %	ACCEPTABLE
242	-1.41	6.58	12.91	25.8 %	ACCEPTABLE
243	-1.29	6.40	12.71	27.4 %	ACCEPTABLE
244	-1.35	6.87	13.19	64.3 %	ACCEPTABLE
245	-1.23	6.68	12.98	64.2 %	ACCEPTABLE
246	-97.77	436.11	449.16	1.9 %	ACCEPTABLE
247	-98.69	445.80	458.84	2.2 %	ACCEPTABLE
248	-97.66	436.11	449.16	2.2 %	ACCEPTABLE
249	-1.32	6.63	12.95	64.6 %	ACCEPTABLE
250	-1.26	6.69	13.00	64.1 %	ACCEPTABLE
251	-1.39	7.01	13.27	17.2 %	ACCEPTABLE
252	-1.30	6.85	13.11	25.8 %	ACCEPTABLE
253	-1.35	6.82	13.13	25.8 %	ACCEPTABLE
254	-1.21	6.45	12.82	63.6 %	ACCEPTABLE
255	-1.33	6.75	13.08	64.2 %	ACCEPTABLE
256	-1.25	6.63	12.95	64.0 %	ACCEPTABLE
257	-1.29	6.57	12.96	63.7 %	ACCEPTABLE
258	-1.31	6.51	12.82	27.4 %	ACCEPTABLE
259	-1.43	6.82	13.08	11.6 %	ACCEPTABLE
260	-1.35	6.69	12.95	16.1 %	ACCEPTABLE
261	-1.39	6.63	12.95	25.8 %	ACCEPTABLE

No.	Center		Radius R [m]	Utilization	Verification
	x [m]	z [m]			
262	-1.29	6.32	12.71	63.7 %	ACCEPTABLE
263	-1.25	6.26	12.64	63.8 %	ACCEPTABLE
264	-1.38	6.56	12.90	64.2 %	ACCEPTABLE
265	-1.29	6.44	12.77	64.2 %	ACCEPTABLE
266	-1.34	6.38	12.78	63.7 %	ACCEPTABLE
267	-1.38	6.60	12.93	64.3 %	ACCEPTABLE
268	-1.30	6.47	12.79	64.3 %	ACCEPTABLE
269	-1.34	6.79	13.11	64.2 %	ACCEPTABLE
270	-1.26	6.66	12.97	64.1 %	ACCEPTABLE
271	-97.92	437.72	450.77	2.2 %	ACCEPTABLE
272	-98.54	444.18	457.22	2.2 %	ACCEPTABLE
273	-97.85	437.72	450.77	2.2 %	ACCEPTABLE
274	-1.32	6.63	12.95	64.6 %	ACCEPTABLE
275	-1.28	6.67	12.98	64.2 %	ACCEPTABLE
276	-1.37	6.88	13.16	27.3 %	ACCEPTABLE
277	-1.31	6.78	13.05	17.3 %	ACCEPTABLE
278	-1.34	6.76	13.07	25.8 %	ACCEPTABLE
279	-1.25	6.51	12.86	63.8 %	ACCEPTABLE
280	-1.33	6.71	13.04	64.2 %	ACCEPTABLE
281	-1.27	6.63	12.95	64.0 %	ACCEPTABLE
282	-1.30	6.59	12.95	64.3 %	ACCEPTABLE
283	-1.31	6.55	12.86	64.4 %	ACCEPTABLE
284	-1.39	6.75	13.04	17.2 %	ACCEPTABLE
285	-1.34	6.67	12.95	27.3 %	ACCEPTABLE
286	-1.37	6.63	12.95	64.4 %	ACCEPTABLE
287	-1.30	6.42	12.79	63.8 %	ACCEPTABLE
288	-1.27	6.38	12.75	63.8 %	ACCEPTABLE
289	-1.36	6.59	12.92	64.3 %	ACCEPTABLE
290	-1.30	6.50	12.83	64.2 %	ACCEPTABLE
291	-1.33	6.46	12.83	64.0 %	ACCEPTABLE
292	-1.36	6.61	12.93	64.2 %	ACCEPTABLE
293	-1.31	6.53	12.85	64.3 %	ACCEPTABLE
294	-1.33	6.73	13.06	64.2 %	ACCEPTABLE
295	-1.28	6.65	12.97	64.3 %	ACCEPTABLE
296	-98.03	438.79	451.84	2.2 %	ACCEPTABLE
297	-98.44	443.10	456.14	2.2 %	ACCEPTABLE
298	-97.98	438.79	451.84	2.2 %	ACCEPTABLE
299	-1.32	6.63	12.95	64.6 %	ACCEPTABLE
300	-1.30	6.66	12.97	64.4 %	ACCEPTABLE
301	-1.35	6.80	13.09	27.2 %	ACCEPTABLE
302	-1.31	6.73	13.02	27.3 %	ACCEPTABLE
303	-1.33	6.71	13.03	64.6 %	ACCEPTABLE
304	-1.27	6.55	12.89	64.1 %	ACCEPTABLE
305	-1.33	6.68	13.01	64.2 %	ACCEPTABLE
306	-1.29	6.63	12.95	64.3 %	ACCEPTABLE
307	-1.31	6.60	12.95	64.0 %	ACCEPTABLE
308	-1.31	6.58	12.89	64.4 %	ACCEPTABLE
309	-1.37	6.71	13.01	25.8 %	ACCEPTABLE
310	-1.33	6.66	12.95	25.8 %	ACCEPTABLE
311	-1.35	6.63	12.95	64.3 %	ACCEPTABLE
312	-1.31	6.49	12.84	64.0 %	ACCEPTABLE
313	-1.29	6.46	12.81	64.0 %	ACCEPTABLE

No.	Center		Radius R [m]	Utilization	Verification
	x [m]	z [m]			
314	-1.34	6.60	12.93	64.2 %	ACCEPTABLE
315	-1.31	6.55	12.87	64.3 %	ACCEPTABLE
316	-1.33	6.52	12.87	64.0 %	ACCEPTABLE
317	-1.35	6.62	12.94	64.2 %	ACCEPTABLE
318	-1.31	6.56	12.88	64.3 %	ACCEPTABLE
319	-1.33	6.70	13.02	64.3 %	ACCEPTABLE
320	-1.29	6.64	12.96	64.3 %	ACCEPTABLE
321	-98.09	439.51	452.55	2.2 %	ACCEPTABLE
322	-98.37	442.38	455.42	2.2 %	ACCEPTABLE
323	-98.06	439.51	452.55	2.1 %	ACCEPTABLE
324	-1.32	6.63	12.95	64.6 %	ACCEPTABLE
325	-1.30	6.65	12.96	64.4 %	ACCEPTABLE
326	-1.34	6.74	13.04	25.7 %	ACCEPTABLE
327	-1.31	6.69	13.00	25.8 %	ACCEPTABLE
328	-1.33	6.69	13.00	25.8 %	ACCEPTABLE
329	-1.29	6.58	12.91	64.2 %	ACCEPTABLE
330	-1.32	6.67	12.99	64.3 %	ACCEPTABLE
331	-1.30	6.63	12.95	64.3 %	ACCEPTABLE
332	-1.31	6.61	12.95	64.4 %	ACCEPTABLE
333	-1.32	6.59	12.91	64.3 %	ACCEPTABLE
334	-1.35	6.68	12.99	25.9 %	ACCEPTABLE
335	-1.33	6.65	12.95	25.8 %	ACCEPTABLE
336	-1.34	6.63	12.95	64.3 %	ACCEPTABLE
337	-1.31	6.54	12.88	64.1 %	ACCEPTABLE
338	-1.30	6.52	12.86	64.1 %	ACCEPTABLE
339	-1.34	6.61	12.94	64.2 %	ACCEPTABLE
340	-1.31	6.57	12.90	64.5 %	ACCEPTABLE
341	-1.32	6.56	12.90	64.1 %	ACCEPTABLE
342	-1.34	6.62	12.94	27.4 %	ACCEPTABLE
343	-1.31	6.58	12.90	64.3 %	ACCEPTABLE
344	-1.33	6.68	13.00	64.3 %	ACCEPTABLE
345	-1.30	6.64	12.96	64.3 %	ACCEPTABLE
346	-98.14	439.99	453.03	2.1 %	ACCEPTABLE
347	-98.32	441.90	454.94	2.2 %	ACCEPTABLE
348	-98.12	439.99	453.03	2.2 %	ACCEPTABLE
349	-1.32	6.63	12.95	64.6 %	ACCEPTABLE

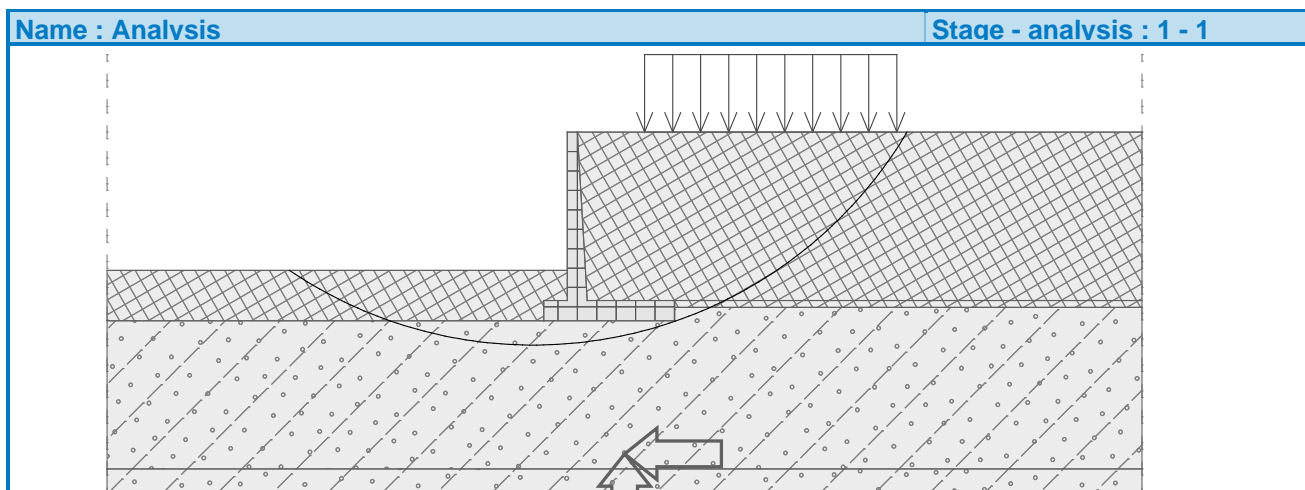

LLOGARITJET KONSTRUKTIVE TE MUREVE ME GABIONA

Gabion analysis

Input data

Project

Author : GJEO KONSULT & CO
 Date : 5/5/2022
 Project ID : Mur Gabioni H=3m ÷ 5m
 Unit weight of water is considered : 9,81 kN/m³

Settings

(input for current task)

Wall analysis

Active earth pressure calculation : Coulomb
 Passive earth pressure calculation : Coulomb
 Earthquake analysis : Mononobe-Okabe
 Shape of earth wedge : Calculate as skew
 Allowable eccentricity : 0.333
 Verification methodology : according to EN 1997
 Design approach : 3 - reduction of actions (GEO, STR) and soil parameters

Partial factors on actions (A)					
Permanent design situation					
		State STR		State GEO	
		Unfavourable	Favourable	Unfavourable	Favourable
Permanent actions :	$\gamma_G =$	1.35 [-]	1.00 [-]	1.00 [-]	1.00 [-]
Variable actions :	$\gamma_Q =$	1.50 [-]	0.00 [-]	1.30 [-]	0.00 [-]
Water load :	$\gamma_w =$			1.00 [-]	

Partial factors for soil parameters (M)			
Permanent design situation			
Partial factor on internal friction :	$\gamma_{\phi} =$	1.25	[-]
Partial factor on effective cohesion :	$\gamma_c =$	1.25	[-]
Partial factor on undrained shear strength :	$\gamma_{cu} =$	1.40	[-]
Partial factor on Poisson's ratio :	$\gamma_v =$	1.00	[-]

Partial factors for variable actions			
Permanent design situation			
Factor for combination value :	$\psi_0 =$	0.70	[-]
Factor for frequent value :	$\psi_1 =$	0.50	[-]
Factor for quasi-permanent value :	$\psi_2 =$	0.30	[-]

Partial factors on actions (A)					
Seismic design situation					
		State STR		State GEO	
		Unfavourable	Favourable	Unfavourable	Favourable
Permanent actions :	$\gamma_G =$	1.00 [-]	1.00 [-]	1.00 [-]	1.00 [-]
Variable actions :	$\gamma_Q =$	1.00 [-]	0.00 [-]	1.00 [-]	0.00 [-]
Water load :	$\gamma_w =$			1.00 [-]	

Partial factors for soil parameters (M)			
Seismic design situation			
Partial factor on internal friction :	$\gamma_{\phi} =$	1.00	[-]
Partial factor on effective cohesion :	$\gamma_c =$	1.00	[-]
Partial factor on undrained shear strength :	$\gamma_{cu} =$	1.00	[-]
Partial factor on Poisson's ratio :	$\gamma_v =$	1.00	[-]

Material of blocks - filling

No.	Name	γ [kN/m ³]	ϕ [°]	c [kPa]
1	Material No. 1	18.50	30.00	0.00

Material of blocks - mesh

No.	Name	Strength overh. R_t [kN/m]	Spacing of vert. meshes v [m]	Bear.cap. of front joint R_s [kN/m]
1	Material No. 1	40.00	1.00	40.00

Geometry of structure

No.	Width b [m]	Height h [m]	Offset a [m]	Material
3	1.00	1.00	0.50	Material No. 1
2	1.50	1.00	0.50	Material No. 1
1	2.00	1.00	-	Material No. 1

Gabion slope = 0.00 °
 Overall height = 3.00 m
 Overall wall volume = 4.50 m³/m

Name : Geometry

Stage - analysis : 1 - 0

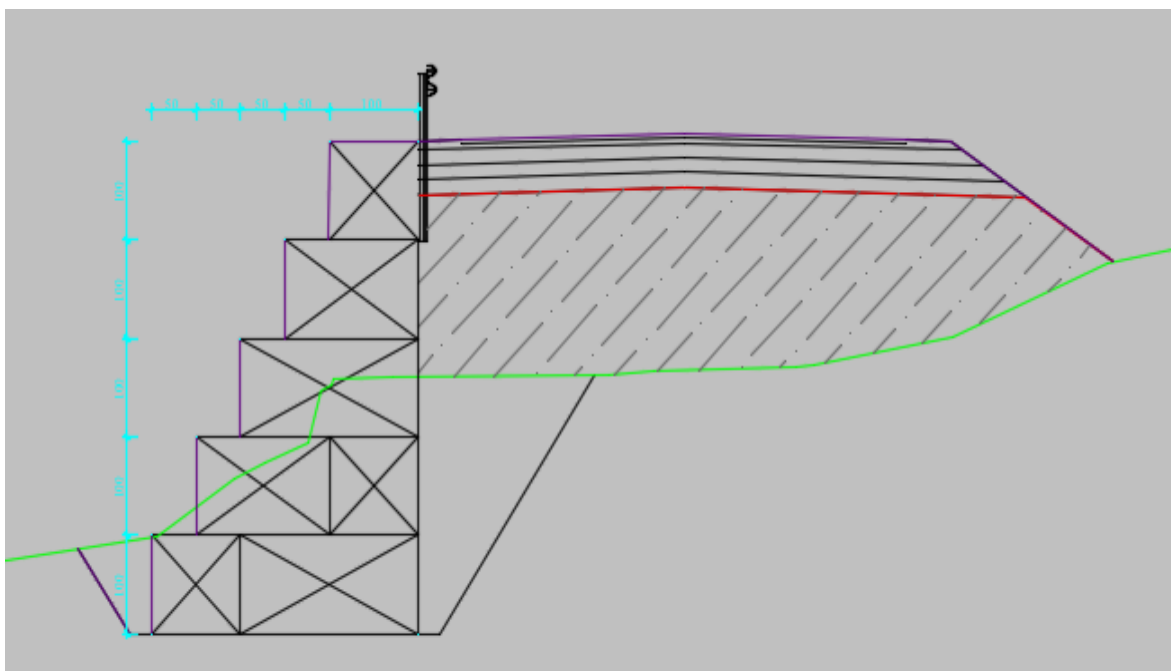
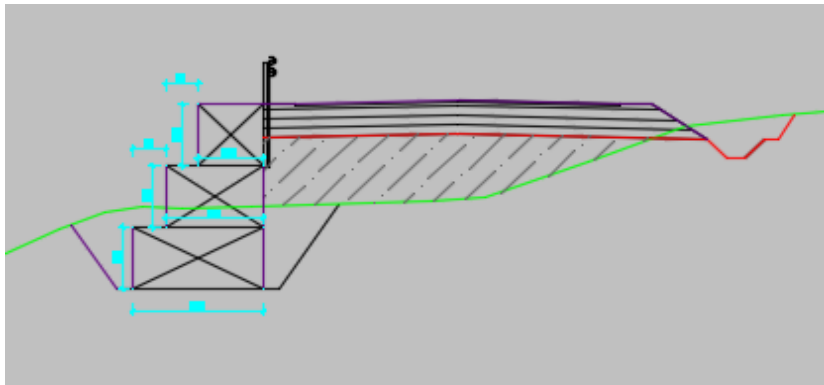

Soil parameters

Mbushje pas murit

Unit weight :	$\gamma = 19.00 \text{ kN/m}^3$
Stress-state :	effective
Angle of internal friction :	$\varphi_{ef} = 35.00^\circ$
Cohesion of soil :	$c_{ef} = 0.00 \text{ kPa}$
Angle of friction struc.-soil :	$\delta = 23.00^\circ$
Soil :	cohesionless
Saturated unit weight :	$\gamma_{sat} = 20.00 \text{ kN/m}^3$





2.Perfaqesohet nga argjila e surera te perziera me zaje te rumbullakosura , ngjyre kafe. Jane pak te ngjeshura.

Unit weight :	$\gamma = 18.75 \text{ kN/m}^3$
Stress-state :	effective
Angle of internal friction :	$\varphi_{ef} = 33.00^\circ$
Cohesion of soil :	$c_{ef} = 14.70 \text{ kPa}$
Angle of friction struc.-soil :	$\delta = 17.00^\circ$
Soil :	cohesionless
Saturated unit weight :	$\gamma_{sat} = 21.27 \text{ kN/m}^3$

3.Perfaqesohet nga depozitime ultrabazike, te tipit dunite, pak te serpentinizuar ngjyre te eret. Takohet ne thellesite mbi 4 m.

Unit weight :	$\gamma = 20.39 \text{ kN/m}^3$
Stress-state :	effective
Angle of internal friction :	$\varphi_{ef} = 33.00^\circ$
Cohesion of soil :	$c_{ef} = 392.2 \text{ kPa}$
Angle of friction struc.-soil :	$\delta = 19.00^\circ$
Soil :	cohesionless
Saturated unit weight :	$\gamma_{sat} = 22.11 \text{ kN/m}^3$

Geological profile and assigned soils

No.	Layer [m]	Assigned soil	Pattern
1	3.00	Mbushje pas murit	
2	4.00	2.Perfaqesohet nga argjila e surera te perziera me zaje te rrumbullakosura , ngjyre kafe. Jane pak te ngjeshura.	
3	10.00	3.Perfaqesohet nga depozitime ultrabazike, te tipit dunite, pak te serpentinizuar ngjyre te eret. Takohet ne thellesite mbi 4 m.	
4	-	3.Perfaqesohet nga depozitime ultrabazike, te tipit dunite, pak te serpentinizuar ngjyre te eret. Takohet ne thellesite mbi 4 m.	

Foundation

Type of foundation : soil from geological profile

Terrain profile

No.	Coordinate x [m]	Depth z [m]
1	0.00	0.00
2	1.50	0.00
3	5.00	-3.00
4	6.00	-3.00

Origin [0,0] is located in upper right edge of construction.
Positive coordinate +z has downward direction.

Input surface surcharges

No.	Surcharge		Action	Mag.1 [kN/m ²]	Mag.2 [kN/m ²]	Ord.x x [m]	Length l [m]	Depth z [m]
	new	change						
1	YES		variable	5.00				on terrain

No.	Name
1	Q

Settings of the stage of construction

Design situation : permanent

Verification No. 1 (Stage of construction 1)

Forces acting on construction

Name	F_{hor} [kN/m]	App.Pt. z [m]	F_{vert} [kN/m]	App.Pt. x [m]	Coeff. overtur.	Coeff. sliding	Coeff. stress
Weight - wall	0.00	-1.28	83.25	1.19	1.000	1.000	1.350
FF resistance	-0.78	-0.13	0.00	0.00	1.000	1.000	1.000
Active pressure	42.86	-0.83	14.95	2.00	1.000	1.000	1.000
Q	6.67	-1.36	2.33	2.00	1.300	1.300	1.300

Verification of complete wall

Check for overturning stability

Resisting moment $M_{res} = 135.38$ kNm/m

Overturning moment $M_{ovr} = 47.08$ kNm/m

Wall for overturning is SATISFACTORY

Check for slip

Resisting horizontal force $H_{res} = 56.70$ kN/m

Active horizontal force $H_{act} = 50.76$ kN/m

Wall for slip is SATISFACTORY

Overall check - WALL is SATISFACTORY

Maximum stress in footing bottom : 69.02 kPa

Bearing capacity of foundation soil (Stage of construction 1)

Design load acting at the center of footing bottom

No.	Moment [kNm/m]	Norm. force [kN/m]	Shear Force [kN/m]	Eccentricity [-]	Stress [kPa]
1	7.26	130.36	50.76	0.028	69.02
2	12.92	101.22	50.76	0.064	58.02

Service load acting at the center of footing bottom

No.	Moment [kNm/m]	Norm. force [kN/m]	Shear Force [kN/m]
1	1.34	99.25	37.04

Verification of foundation soil

Eccentricity verification

Max. eccentricity of normal force $e = 0.028$

Maximum allowable eccentricity $e_{alw} = 0.333$

Eccentricity of the normal force is SATISFACTORY

Verification of bearing capacity

Max. stress at footing bottom $\sigma = 69.02$ kPa

Bearing capacity of foundation soil $R_d = 147.00$ kPa

Bearing capacity of foundation soil is SATISFACTORY

Overall verification - bearing capacity of found. soil is SATISFACTORY

Dimensioning No. 1 (Stage of construction 1)

Forces acting on construction

Name	F_{hor} [kN/m]	App.Pt. z [m]	F_{vert} [kN/m]	App.Pt. x [m]	Coeff. overtur.	Coeff. sliding	Coeff. stress
Weight - wall	0.00	-0.90	46.25	0.85	1.000	1.000	1.350
Active pressure	13.96	-0.57	4.87	1.50	1.000	1.000	1.000
Q	4.29	-0.77	1.50	1.50	1.300	1.300	1.300

Verification of the most stressed construction joint - above the block No. 1

Check for overturning stability

Resisting moment $M_{res} = 49.53$ kNm/m

Overturning moment $M_{ovr} = 12.22$ kNm/m

Joint for overturning stability is SATISFACTORY

Check for slip

Resisting horizontal force $H_{res} = 24.51$ kN/m

Active horizontal force $H_{act} = 19.54$ kN/m

Joint for slip is SATISFACTORY

Maximum pressure on the bottom block = 46.95 kPa
 Red.Coeff. by offset of top block = 0.13
 Average value of pressure on face = 7.69 kPa
 Shear force transmitted by friction = 31.99 kN/m

Bearing capacity against transverse pressure:

Joint bear.capacity = 40.00 kN/m

Computed stress-state = 3.85 kN/m

Transverse pressure check is SATISFACTORY

Joint btw. blocks check:

Mesh material bear.capacity = 40.00 kN/m

Computed stress-state = 3.85 kN/m

Joint between blocks is SATISFACTORY

Slope stability analysis

Input data

Project

Settings

(input for current task)

Stability analysis

Earthquake analysis : Standard

Verification methodology : Safety factors (ASD)

Safety factors	
Permanent design situation	
Safety factor :	$SF_s = 1.50$ [-]

Interface

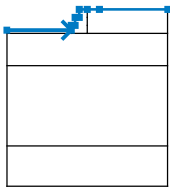
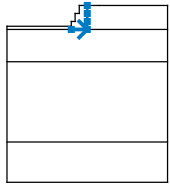
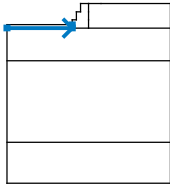
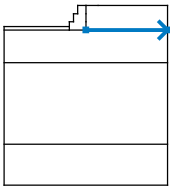
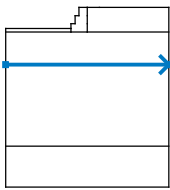
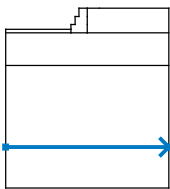
No.	Interface location	Coordinates of interface points [m]					
		x	z	x	z	x	z
1		-10.00	-2.60	-2.00	-2.60	-2.00	-2.00
		-1.50	-2.00	-1.50	-1.00	-1.00	-1.00
		-1.00	0.00	0.00	0.00	1.50	0.00
		10.00	0.00				
2		-2.00	-3.00	0.00	-3.00	0.00	-2.00
		0.00	-1.00	0.00	0.00		
3		-10.00	-3.00	-2.00	-3.00	-2.00	-2.60
4		0.00	-3.00	10.00	-3.00		
5		-10.00	-7.00	10.00	-7.00		
6		-10.00	-17.00	10.00	-17.00		

Soil parameters - effective stress state

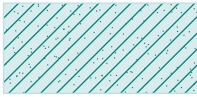
No.	Name	Pattern	Φ_{ef} [°]	C_{ef} [kPa]	γ [kN/m ³]
1	Mbushje pas murit		35.00	0.00	19.00
2	2.Perfaqesohet nga argjila e surera te perziera me zaje te rrumbullakosura , ngjyre kafe. Jane pak te ngjeshura.		33.00	14.70	18.75

No.	Name	Pattern	φ_{ef} [°]	c_{ef} [kPa]	γ [kN/m ³]
3	3.Perfaqesohet nga depozitime ultrabazike, te tipit dunitite, pak te serpentinizuar ngjyre te eret. Takohet ne thellesite mbi 4 m.		33.00	392.26	20.39

Soil parameters - uplift

No.	Name	Pattern	γ_{sat} [kN/m ³]	γ_s [kN/m ³]	n [-]
1	Mbushje pas murit		20.00		
2	2.Perfaqesohet nga argjila e surera te perziera me zaje te rrumbullakosura , ngjyre kafe. Jane pak te ngjeshura.		21.27		
3	3.Perfaqesohet nga depozitime ultrabazike, te tipit dunitite, pak te serpentinizuar ngjyre te eret. Takohet ne thellesite mbi 4 m.		22.11		

Soil parameters

Mbushje pas murit

Unit weight :	γ	=	19.00 kN/m ³
Stress-state :	effective		
Angle of internal friction :	φ_{ef}	=	35.00 °
Cohesion of soil :	c_{ef}	=	0.00 kPa
Saturated unit weight :	γ_{sat}	=	20.00 kN/m ³

2.Perfaqesohet nga argjila e surera te perziera me zaje te rrumbullakosura , ngjyre kafe. Jane pak te ngjeshura.

Unit weight :	γ	=	18.75 kN/m ³
Stress-state :	effective		
Angle of internal friction :	φ_{ef}	=	33.00 °
Cohesion of soil :	c_{ef}	=	14.70 kPa
Saturated unit weight :	γ_{sat}	=	21.27 kN/m ³







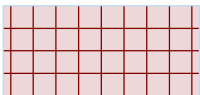

3.Perfaqesohet nga depozitime ultrabazike, te tipit dunitite, pak te serpentinizuar ngjyre te eret. Takohet ne thellesite mbi 4 m.

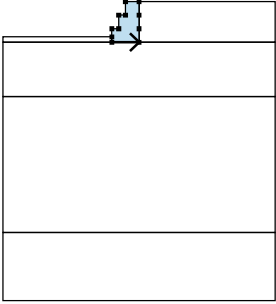
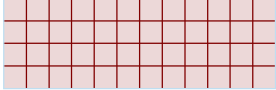
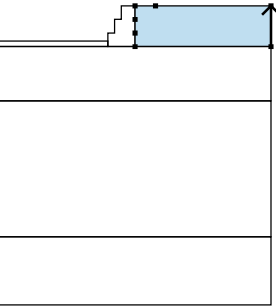

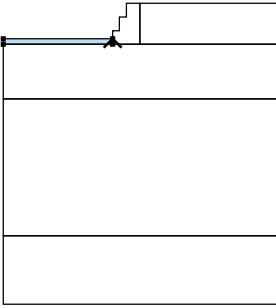
Unit weight :	γ	=	20.39 kN/m ³
Stress-state :	effective		
Angle of internal friction :	φ_{ef}	=	33.00 °
Cohesion of soil :	c_{ef}	=	392.26 kPa
Saturated unit weight :	γ_{sat}	=	22.11 kN/m ³

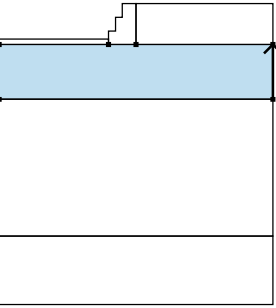
Rigid bodies

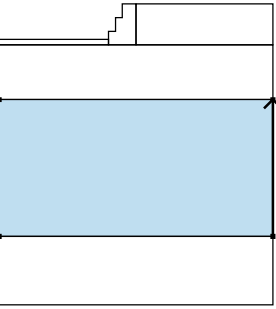
No.	Name	Sample	γ [kN/m ³]
1	Wall material		18.50

Assigning and surfaces

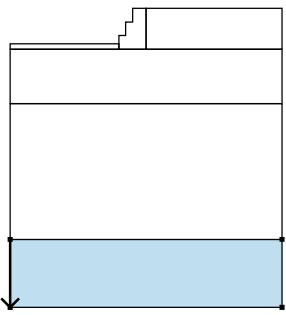
No.	Surface position	Coordinates of surface points [m]				Assigned soil
		x	z	x	z	
1		-2.00	-3.00	0.00	-3.00	Wall material 
		0.00	-2.00	0.00	-1.00	
		0.00	0.00	-1.00	0.00	
		-1.00	-1.00	-1.50	-1.00	
		-1.50	-2.00	-2.00	-2.00	
		-2.00	-2.60			
2		10.00	-3.00	10.00	0.00	Mbushje pas murit 
		1.50	0.00	0.00	0.00	
		0.00	-1.00	0.00	-2.00	
		0.00	-3.00			
3		-2.00	-3.00	-2.00	-2.60	Mbushje pas murit 
		-10.00	-2.60	-10.00	-3.00	
4		10.00	-7.00	10.00	-3.00	Mbushje pas murit 
		0.00	-3.00	-2.00	-3.00	
		-10.00	-3.00	-10.00	-7.00	
5		10.00	-17.00	10.00	-7.00	3.Perfaqesohet nga depozitime ultrabazike, te 
		-10.00	-7.00	-10.00	-17.00	

No.	Surface position	Coordinates of surface points [m]				Assigned soil
		x	z	x	z	
6		-10.00	-17.00	-10.00	-22.00	3.Perfaqesohet nga depozitime ultrabazike, te
		10.00	-22.00	10.00	-17.00	
						

Surcharge

No.	Type	Type of action	Location z [m]	Origin x [m]	Length l [m]	Width b [m]	Slope α [°]	Magnitude	
								q, q ₁ , f, F	q ₂ unit
1	strip	variable	on terrain	x = 0.00	l = 10.00		0.00	5.00	kN/m ²

Surcharges

No.	Name
1	Q

Water

Water type : No water

Tensile crack

Tensile crack not inputted.

Earthquake

Earthquake not included.

Settings of the stage of construction

Design situation : permanent

Results (Stage of construction 1)

Analysis 1

Circular slip surface

Slip surface parameters					
Center :	x =	-1.74 [m]	Angles :	$\alpha_1 =$	-33.86 [°]
	z =	1.17 [m]		$\alpha_2 =$	75.07 [°]
Radius :	R =	4.54 [m]			
The slip surface after optimization.					

Slope stability verification (Bishop)

Sum of active forces : $F_a = 82.24$ kN/m

Sum of passive forces : $F_p = 158.77$ kN/m

Sliding moment : $M_a = 373.37$ kNm/m

Resisting moment : $M_p = 720.81$ kNm/m

Factor of safety = 1.93 > 1.50

Slope stability ACCEPTABLE

Optimization of circular slip surface (Bishop)

No.	Center		Radius R [m]	FS	Verification
	x [m]	z [m]			
1	-1.01	0.95	4.08	2.15	ACCEPTABLE

No.	Center		Radius R [m]	FS	Verification
	x [m]	z [m]			
2	-1.01	0.95	4.08	2.15	ACCEPTABLE
3	-1.01	0.95	4.08	2.15	ACCEPTABLE
4	-3.04	14.69	17.73	267.94	ACCEPTABLE
5	-1.23	5.06	9.55	3.58	ACCEPTABLE
6	-0.33	0.27	7.21	6.09	ACCEPTABLE
7	-4.93	0.95	4.08	7799.10	ACCEPTABLE
8	-2.59	12.29	15.51	11.31	ACCEPTABLE
9	-1.01	0.95	4.08	2.15	ACCEPTABLE
10	2.58	11.04	11.44	1648190.53	ACCEPTABLE
11	-2.48	9.26	12.27	277.14	ACCEPTABLE
12	-1.20	3.73	7.73	3.06	ACCEPTABLE
13	-0.42	0.36	6.00	4.42	ACCEPTABLE
14	0.09	0.10	0.51	212491.62	ACCEPTABLE
15	-3.62	0.95	4.08	772.36	ACCEPTABLE
16	-2.08	7.51	10.72	2.63	ACCEPTABLE
17	-18.77	21.26	28.58	1624.69	ACCEPTABLE
18	-1.01	0.95	4.08	2.15	ACCEPTABLE
19	0.78	5.09	6.43	1315.15	ACCEPTABLE
20	-2.05	6.05	9.07	218.82	ACCEPTABLE
21	-1.17	2.84	6.52	2.56	ACCEPTABLE
22	1.61	0.07	3.09	2940.30	ACCEPTABLE
23	-0.52	0.46	5.24	3.61	ACCEPTABLE
24	-0.35	0.29	1.59	1137.10	ACCEPTABLE
25	-2.75	0.95	4.08	339.79	ACCEPTABLE
26	-1.73	4.88	8.07	8.60	ACCEPTABLE
27	-19.83	29.54	36.26	924.34	ACCEPTABLE
28	-27.08	81.62	87.59	541.91	ACCEPTABLE
29	-1.01	0.95	4.08	2.15	ACCEPTABLE
30	-5.34	15.64	18.28	486.93	ACCEPTABLE
31	-0.68	4.42	6.53	526.18	ACCEPTABLE
32	-1.73	4.13	7.17	149.56	ACCEPTABLE
33	-1.14	2.23	5.71	2.38	ACCEPTABLE
34	0.64	0.47	3.51	640.03	ACCEPTABLE
35	-0.61	0.56	4.77	3.12	ACCEPTABLE
36	-3.04	2.96	5.67	422.49	ACCEPTABLE
37	-1.20	1.13	3.20	515.02	ACCEPTABLE
38	-2.17	0.95	4.08	189.17	ACCEPTABLE
39	-1.82	0.13	3.61	6.52	ACCEPTABLE
40	-1.50	3.37	6.55	2.32	ACCEPTABLE
41	0.66	0.40	3.48	633.58	ACCEPTABLE
42	-20.80	36.11	42.60	840.27	ACCEPTABLE
43	-1.01	0.95	4.08	2.15	ACCEPTABLE
44	-0.37	1.25	4.29	202.92	ACCEPTABLE
45	-2.79	6.70	9.35	378.19	ACCEPTABLE
46	-1.52	3.90	6.54	360.24	ACCEPTABLE
47	-1.51	2.97	6.02	101.55	ACCEPTABLE
48	-1.11	1.82	5.17	2.29	ACCEPTABLE
49	-0.24	0.95	4.08	151.18	ACCEPTABLE
50	-0.70	0.65	4.48	2.79	ACCEPTABLE
51	-2.37	2.29	5.10	340.12	ACCEPTABLE
52	-1.82	1.75	4.37	364.20	ACCEPTABLE
53	-1.78	0.95	4.08	117.75	ACCEPTABLE

No.	Center		Radius R [m]	FS	Verification
	x [m]	z [m]			
54	-1.56	0.43	3.77	1.95	ACCEPTABLE
55	-0.77	0.40	3.75	2.46	ACCEPTABLE
56	-2.91	4.78	7.57	326.94	ACCEPTABLE
57	-1.72	2.58	5.34	306.74	ACCEPTABLE
58	-1.97	2.07	5.35	40.43	ACCEPTABLE
59	-1.69	1.26	4.82	2.13	ACCEPTABLE
60	-0.79	0.43	3.77	2.44	ACCEPTABLE
61	-1.34	0.23	4.30	2.65	ACCEPTABLE
62	-2.81	1.53	4.49	397.70	ACCEPTABLE
63	-2.09	0.89	3.61	408.81	ACCEPTABLE
64	-2.33	0.43	3.77	137.67	ACCEPTABLE
65	-2.17	0.05	3.58	53.37	ACCEPTABLE
66	-1.87	1.76	5.14	1.98	ACCEPTABLE
67	-0.86	0.60	3.87	2.33	ACCEPTABLE
68	-21.53	40.96	47.33	628.04	ACCEPTABLE
69	-1.56	0.43	3.77	1.95	ACCEPTABLE
70	-1.11	0.59	3.86	2.15	ACCEPTABLE
71	-2.33	2.81	5.77	291.53	ACCEPTABLE
72	-1.58	1.65	4.59	288.90	ACCEPTABLE
73	-1.84	1.49	4.78	29.83	ACCEPTABLE
74	-1.66	0.99	4.47	2.05	ACCEPTABLE
75	-1.04	0.43	3.77	2.24	ACCEPTABLE
76	-1.40	0.28	4.11	2.41	ACCEPTABLE
77	-2.40	1.18	4.24	293.76	ACCEPTABLE
78	-1.85	0.68	3.58	349.85	ACCEPTABLE
79	-2.08	0.43	3.77	89.24	ACCEPTABLE
80	-1.97	0.19	3.65	35.53	ACCEPTABLE
81	-1.77	1.28	4.65	1.95	ACCEPTABLE
82	-1.11	0.58	3.85	2.15	ACCEPTABLE
83	-22.84	44.53	50.83	956.19	ACCEPTABLE
84	-25.05	59.99	66.10	684.25	ACCEPTABLE
85	-22.33	44.53	50.83	682.99	ACCEPTABLE
86	-1.56	0.43	3.77	1.95	ACCEPTABLE
87	-1.29	0.60	3.86	2.04	ACCEPTABLE
88	-2.04	1.85	4.93	172.92	ACCEPTABLE
89	-1.54	1.18	4.24	130.17	ACCEPTABLE
90	-1.75	1.12	4.42	24.69	ACCEPTABLE
91	-1.63	0.81	4.24	2.02	ACCEPTABLE
92	-1.22	0.43	3.77	2.12	ACCEPTABLE
93	-1.44	0.33	3.98	2.25	ACCEPTABLE
94	-1.46	0.02	3.30	27.68	ACCEPTABLE
95	-2.12	0.94	4.07	182.94	ACCEPTABLE
96	-1.73	0.58	3.62	205.75	ACCEPTABLE
97	-1.90	0.43	3.77	57.39	ACCEPTABLE
98	-1.76	0.10	3.60	1.99	ACCEPTABLE
99	-1.84	0.28	3.69	29.29	ACCEPTABLE
100	-1.70	0.98	4.34	1.95	ACCEPTABLE
101	-1.26	0.54	3.83	2.07	ACCEPTABLE
102	-23.19	46.93	53.19	888.84	ACCEPTABLE
103	-24.67	57.23	63.36	717.63	ACCEPTABLE
104	-22.85	46.93	53.19	716.90	ACCEPTABLE
105	-1.56	0.43	3.77	1.95	ACCEPTABLE

No.	Center		Radius R [m]	FS	Verification
	x [m]	z [m]			
106	-1.39	0.57	3.85	1.99	ACCEPTABLE
107	-1.86	1.31	4.48	98.19	ACCEPTABLE
108	-1.54	0.90	4.05	71.04	ACCEPTABLE
109	-1.69	0.88	4.20	15.38	ACCEPTABLE
110	-1.18	0.08	3.60	2.29	ACCEPTABLE
111	-1.61	0.69	4.08	1.98	ACCEPTABLE
112	-1.33	0.43	3.77	2.06	ACCEPTABLE
113	-1.48	0.36	3.91	2.15	ACCEPTABLE
114	-1.50	0.16	3.46	23.31	ACCEPTABLE
115	-1.94	0.77	3.97	112.53	ACCEPTABLE
116	-1.67	0.52	3.66	112.36	ACCEPTABLE
117	-1.79	0.43	3.77	38.28	ACCEPTABLE
118	-1.70	0.22	3.66	1.96	ACCEPTABLE
119	-1.42	0.01	3.38	2.04	ACCEPTABLE
120	-1.75	0.33	3.72	20.07	ACCEPTABLE
121	-1.46	0.09	3.42	1.98	ACCEPTABLE
122	-1.65	0.79	4.14	1.94	ACCEPTABLE
123	-1.48	0.95	4.24	1.98	ACCEPTABLE
124	-1.96	1.75	4.92	101.03	ACCEPTABLE
125	-1.63	1.31	4.47	68.60	ACCEPTABLE
126	-1.78	1.28	4.60	20.35	ACCEPTABLE
127	-1.27	0.41	3.93	2.22	ACCEPTABLE
128	-1.70	1.06	4.47	1.97	ACCEPTABLE
129	-1.42	0.79	4.14	2.04	ACCEPTABLE
130	-1.56	0.70	4.26	2.13	ACCEPTABLE
131	-1.59	0.51	3.81	19.38	ACCEPTABLE
132	-2.03	1.16	4.37	105.43	ACCEPTABLE
133	-1.76	0.90	4.05	107.02	ACCEPTABLE
134	-1.88	0.79	4.14	34.06	ACCEPTABLE
135	-1.53	0.15	3.72	2.14	ACCEPTABLE
136	-1.38	0.03	3.57	2.19	ACCEPTABLE
137	-1.79	0.56	4.01	1.94	ACCEPTABLE
138	-1.61	0.69	4.08	1.98	ACCEPTABLE
139	-2.07	1.45	4.71	79.84	ACCEPTABLE
140	-1.75	1.03	4.29	42.56	ACCEPTABLE
141	-1.91	1.01	4.44	1.94	ACCEPTABLE
142	-1.74	1.17	4.54	1.93	ACCEPTABLE
143	-1.58	1.35	4.65	1.98	ACCEPTABLE
144	-2.05	2.21	5.40	89.38	ACCEPTABLE
145	-1.72	1.74	4.92	61.59	ACCEPTABLE
146	-1.87	1.69	5.04	6.71	ACCEPTABLE
147	-1.36	0.76	4.30	2.20	ACCEPTABLE
148	-1.78	1.46	4.88	2.01	ACCEPTABLE
149	-1.51	1.17	4.54	2.05	ACCEPTABLE
150	-1.65	1.07	4.65	2.15	ACCEPTABLE
151	-1.69	0.87	4.19	15.37	ACCEPTABLE
152	-2.12	1.58	4.81	93.43	ACCEPTABLE
153	-1.86	1.30	4.47	98.04	ACCEPTABLE
154	-1.97	1.17	4.54	29.73	ACCEPTABLE
155	-1.62	0.48	4.06	2.12	ACCEPTABLE
156	-1.47	0.35	3.91	2.16	ACCEPTABLE
157	-1.88	0.92	4.39	1.97	ACCEPTABLE

No.	Center		Radius R [m]	FS	Verification
	x [m]	z [m]			
158	-1.61	0.68	4.08	1.99	ACCEPTABLE
159	-1.76	0.61	4.22	2.10	ACCEPTABLE
160	-1.93	1.05	4.47	6.55	ACCEPTABLE
161	-1.65	0.78	4.14	1.95	ACCEPTABLE
162	-1.83	1.59	4.96	1.97	ACCEPTABLE
163	-1.55	1.27	4.60	2.01	ACCEPTABLE
164	-23.43	48.56	54.80	849.19	ACCEPTABLE
165	-24.42	55.43	61.58	741.59	ACCEPTABLE
166	-23.20	48.56	54.80	729.23	ACCEPTABLE
167	-1.74	1.17	4.54	1.93	ACCEPTABLE
168	-1.64	1.30	4.62	1.97	ACCEPTABLE
169	-1.94	1.83	5.08	54.16	ACCEPTABLE
170	-1.72	1.54	4.78	33.74	ACCEPTABLE
171	-1.83	1.52	4.87	6.65	ACCEPTABLE
172	-1.49	0.90	4.38	2.11	ACCEPTABLE
173	-1.77	1.36	4.77	1.99	ACCEPTABLE
174	-1.59	1.17	4.54	2.01	ACCEPTABLE
175	-1.68	1.10	4.61	2.08	ACCEPTABLE
176	-1.70	0.97	4.31	10.98	ACCEPTABLE
177	-2.00	1.44	4.72	58.58	ACCEPTABLE
178	-1.82	1.25	4.49	55.99	ACCEPTABLE
179	-1.89	1.17	4.54	20.34	ACCEPTABLE
180	-1.65	0.69	4.21	2.07	ACCEPTABLE
181	-1.56	0.60	4.10	2.08	ACCEPTABLE
182	-1.83	1.01	4.44	1.95	ACCEPTABLE
183	-1.65	0.84	4.23	1.97	ACCEPTABLE
184	-1.75	0.78	4.31	2.03	ACCEPTABLE
185	-1.86	1.09	4.49	6.54	ACCEPTABLE
186	-1.68	0.91	4.27	1.95	ACCEPTABLE
187	-1.80	1.44	4.82	1.97	ACCEPTABLE
188	-1.61	1.24	4.58	1.99	ACCEPTABLE
189	-26.10	64.28	70.35	812.66	ACCEPTABLE
190	-26.80	69.57	75.60	754.48	ACCEPTABLE
191	-25.94	64.28	70.35	754.87	ACCEPTABLE
192	-1.74	1.17	4.54	1.93	ACCEPTABLE
193	-1.67	1.26	4.60	1.97	ACCEPTABLE
194	-1.87	1.60	4.89	34.69	ACCEPTABLE
195	-1.73	1.41	4.69	22.65	ACCEPTABLE
196	-1.80	1.40	4.76	1.95	ACCEPTABLE
197	-1.57	0.99	4.43	2.06	ACCEPTABLE
198	-1.76	1.30	4.69	1.97	ACCEPTABLE
199	-1.64	1.17	4.54	1.99	ACCEPTABLE
200	-1.70	1.12	4.58	2.03	ACCEPTABLE
201	-1.72	1.04	4.39	6.08	ACCEPTABLE
202	-1.91	1.35	4.66	39.27	ACCEPTABLE
203	-1.79	1.22	4.50	39.35	ACCEPTABLE
204	-1.84	1.17	4.54	15.71	ACCEPTABLE
205	-1.68	0.84	4.31	2.03	ACCEPTABLE
206	-1.62	0.78	4.24	2.03	ACCEPTABLE
207	-1.80	1.07	4.48	1.96	ACCEPTABLE
208	-1.68	0.95	4.33	1.97	ACCEPTABLE
209	-1.74	0.91	4.38	2.01	ACCEPTABLE





No.	Center		Radius R [m]	FS	Verification
	x [m]	z [m]			
210	-1.82	1.12	4.51	1.94	ACCEPTABLE
211	-1.70	0.99	4.36	1.95	ACCEPTABLE
212	-1.78	1.35	4.73	1.96	ACCEPTABLE
213	-1.66	1.22	4.57	1.97	ACCEPTABLE
214	-26.21	65.14	71.21	796.61	ACCEPTABLE
215	-26.68	68.67	74.71	762.10	ACCEPTABLE
216	-26.11	65.14	71.21	751.04	ACCEPTABLE
217	-1.74	1.17	4.54	1.93	ACCEPTABLE
218	-1.69	1.23	4.58	1.96	ACCEPTABLE
219	-1.83	1.45	4.77	15.94	ACCEPTABLE
220	-1.73	1.33	4.64	15.72	ACCEPTABLE
221	-1.78	1.32	4.68	1.94	ACCEPTABLE
222	-1.63	1.05	4.47	2.02	ACCEPTABLE
223	-1.75	1.26	4.64	1.97	ACCEPTABLE
224	-1.67	1.17	4.54	1.98	ACCEPTABLE
225	-1.71	1.14	4.57	2.01	ACCEPTABLE
226	-1.73	1.08	4.44	1.94	ACCEPTABLE
227	-1.85	1.29	4.62	20.42	ACCEPTABLE
228	-1.77	1.21	4.51	24.81	ACCEPTABLE
229	-1.81	1.17	4.54	11.12	ACCEPTABLE
230	-1.70	0.95	4.38	2.00	ACCEPTABLE
231	-1.66	0.91	4.33	2.00	ACCEPTABLE
232	-1.78	1.10	4.50	1.95	ACCEPTABLE
233	-1.70	1.02	4.40	1.96	ACCEPTABLE
234	-1.74	0.99	4.43	1.99	ACCEPTABLE
235	-1.80	1.14	4.52	6.54	ACCEPTABLE
236	-1.71	1.05	4.42	1.95	ACCEPTABLE
237	-1.77	1.29	4.66	1.96	ACCEPTABLE
238	-1.68	1.20	4.56	1.97	ACCEPTABLE
239	-26.29	65.72	71.78	800.92	ACCEPTABLE
240	-26.60	68.07	74.12	758.05	ACCEPTABLE
241	-26.22	65.72	71.78	774.10	ACCEPTABLE
242	-1.74	1.17	4.54	1.93	ACCEPTABLE
243	-1.71	1.21	4.57	1.96	ACCEPTABLE
244	-1.80	1.36	4.69	14.57	ACCEPTABLE
245	-1.73	1.27	4.61	1.95	ACCEPTABLE
246	-1.77	1.27	4.64	1.95	ACCEPTABLE
247	-1.66	1.09	4.49	2.00	ACCEPTABLE
248	-1.75	1.23	4.61	1.97	ACCEPTABLE
249	-1.69	1.17	4.54	1.97	ACCEPTABLE
250	-1.72	1.15	4.56	1.99	ACCEPTABLE
251	-1.73	1.11	4.47	1.94	ACCEPTABLE
252	-1.82	1.25	4.59	15.77	ACCEPTABLE
253	-1.76	1.19	4.52	15.67	ACCEPTABLE
254	-1.79	1.17	4.54	6.55	ACCEPTABLE
255	-1.71	1.02	4.43	1.98	ACCEPTABLE
256	-1.68	0.99	4.40	1.99	ACCEPTABLE
257	-1.77	1.13	4.51	1.95	ACCEPTABLE
258	-1.71	1.07	4.45	1.96	ACCEPTABLE
259	-1.74	1.05	4.47	1.98	ACCEPTABLE
260	-1.78	1.15	4.53	1.94	ACCEPTABLE
261	-1.72	1.09	4.46	1.95	ACCEPTABLE

No.	Center		Radius R [m]	FS	Verification
	x [m]	z [m]			
262	-1.76	1.25	4.62	1.96	ACCEPTABLE
263	-1.70	1.19	4.55	1.96	ACCEPTABLE
264	-26.34	66.11	72.17	785.55	ACCEPTABLE
265	-26.55	67.68	73.73	772.33	ACCEPTABLE
266	-26.30	66.11	72.17	777.90	ACCEPTABLE
267	-1.74	1.17	4.54	1.93	ACCEPTABLE
268	-1.72	1.20	4.56	1.96	ACCEPTABLE
269	-1.78	1.29	4.64	11.18	ACCEPTABLE
270	-1.74	1.24	4.58	6.56	ACCEPTABLE
271	-1.76	1.24	4.60	1.95	ACCEPTABLE
272	-1.69	1.12	4.51	1.98	ACCEPTABLE
273	-1.75	1.21	4.59	1.96	ACCEPTABLE
274	-1.71	1.17	4.54	1.97	ACCEPTABLE
275	-1.73	1.16	4.55	1.97	ACCEPTABLE
276	-1.73	1.13	4.49	1.94	ACCEPTABLE
277	-1.79	1.22	4.57	11.14	ACCEPTABLE
278	-1.75	1.19	4.53	11.11	ACCEPTABLE
279	-1.77	1.17	4.54	1.95	ACCEPTABLE
280	-1.72	1.07	4.47	1.98	ACCEPTABLE
281	-1.70	1.05	4.45	1.98	ACCEPTABLE
282	-1.76	1.14	4.52	1.96	ACCEPTABLE
283	-1.72	1.10	4.48	1.96	ACCEPTABLE
284	-1.74	1.09	4.49	1.97	ACCEPTABLE
285	-1.76	1.16	4.53	1.95	ACCEPTABLE
286	-1.73	1.12	4.49	1.95	ACCEPTABLE
287	-1.75	1.22	4.59	1.96	ACCEPTABLE
288	-1.72	1.18	4.55	1.96	ACCEPTABLE
289	-26.38	66.37	72.43	785.55	ACCEPTABLE
290	-26.52	67.42	73.47	772.27	ACCEPTABLE
291	-26.35	66.37	72.43	774.13	ACCEPTABLE
292	-1.74	1.17	4.54	1.93	ACCEPTABLE
293	-1.73	1.19	4.55	1.95	ACCEPTABLE
294	-1.77	1.25	4.61	6.57	ACCEPTABLE
295	-1.74	1.22	4.57	1.94	ACCEPTABLE
296	-1.75	1.21	4.58	1.95	ACCEPTABLE
297	-1.71	1.13	4.52	1.98	ACCEPTABLE
298	-1.74	1.20	4.57	1.95	ACCEPTABLE
299	-1.72	1.17	4.54	1.96	ACCEPTABLE
300	-1.73	1.16	4.55	1.97	ACCEPTABLE
301	-1.74	1.14	4.51	1.95	ACCEPTABLE
302	-1.77	1.21	4.56	6.55	ACCEPTABLE
303	-1.75	1.18	4.53	6.54	ACCEPTABLE
304	-1.76	1.17	4.54	1.95	ACCEPTABLE
305	-1.73	1.10	4.49	1.97	ACCEPTABLE
306	-1.72	1.09	4.48	1.97	ACCEPTABLE
307	-1.75	1.15	4.53	1.96	ACCEPTABLE
308	-1.73	1.13	4.50	1.96	ACCEPTABLE
309	-1.74	1.12	4.51	1.96	ACCEPTABLE
310	-1.76	1.16	4.53	1.95	ACCEPTABLE
311	-1.73	1.13	4.50	1.96	ACCEPTABLE
312	-1.75	1.21	4.58	1.95	ACCEPTABLE
313	-1.72	1.18	4.55	1.96	ACCEPTABLE

No.	Center		Radius R [m]	FS	Verification
	x [m]	z [m]			
314	-26.40	66.54	72.60	781.63	ACCEPTABLE
315	-26.49	67.24	73.29	773.58	ACCEPTABLE
316	-26.38	66.54	72.60	765.21	ACCEPTABLE
317	-1.74	1.17	4.54	1.93	ACCEPTABLE
318	-1.73	1.18	4.55	1.96	ACCEPTABLE
319	-1.76	1.22	4.58	6.56	ACCEPTABLE
320	-1.74	1.20	4.56	1.95	ACCEPTABLE
321	-1.75	1.20	4.57	1.95	ACCEPTABLE
322	-1.72	1.15	4.53	1.97	ACCEPTABLE
323	-1.74	1.19	4.56	1.96	ACCEPTABLE
324	-1.73	1.17	4.54	1.96	ACCEPTABLE
325	-1.73	1.16	4.55	1.97	ACCEPTABLE
326	-1.74	1.15	4.52	1.95	ACCEPTABLE
327	-1.76	1.19	4.55	1.94	ACCEPTABLE
328	-1.75	1.18	4.53	6.54	ACCEPTABLE
329	-1.75	1.17	4.54	1.95	ACCEPTABLE
330	-1.73	1.13	4.51	1.94	ACCEPTABLE
331	-1.72	1.12	4.50	1.96	ACCEPTABLE
332	-1.75	1.16	4.53	1.95	ACCEPTABLE
333	-1.73	1.14	4.51	1.96	ACCEPTABLE
334	-1.74	1.13	4.52	1.97	ACCEPTABLE
335	-1.75	1.16	4.54	1.96	ACCEPTABLE
336	-1.73	1.15	4.52	1.96	ACCEPTABLE
337	-1.75	1.19	4.56	1.96	ACCEPTABLE
338	-1.73	1.18	4.54	1.95	ACCEPTABLE
339	-26.42	66.66	72.72	781.93	ACCEPTABLE
340	-26.48	67.12	73.18	767.34	ACCEPTABLE
341	-26.40	66.66	72.72	767.29	ACCEPTABLE
342	-1.74	1.17	4.54	1.93	ACCEPTABLE

Input data (Stage of construction 2)

Geological profile and assigned soils

No.	Layer [m]	Assigned soil	Pattern
1	3.00	Mbushje pas murit	
2	4.00	2.Perfaqesohet nga argjila e surera te perziera me zaje te rrumbullakosura , ngjyre kafe. Jane pak te ngjeshura.	
3	10.00	3.Perfaqesohet nga depozitime ultrabazike, te tipit dunitite, pak te serpentinizuar ngjyre te eret. Takohet ne thellesite mbi 4 m.	
4	-	3.Perfaqesohet nga depozitime ultrabazike, te tipit dunitite, pak te serpentinizuar ngjyre te eret. Takohet ne thellesite mbi 4 m.	

Foundation

Type of foundation : soil from geological profile

Terrain profile

No.	Coordinate x [m]	Depth z [m]
1	0.00	0.00

No.	Coordinate x [m]	Depth z [m]
2	1.50	0.00
3	5.00	-3.00
4	6.00	-3.00

Origin [0,0] is located in upper right edge of construction.
Positive coordinate +z has downward direction.

Water influence

Ground water table is located below the structure.

Input surface surcharges

No.	Surcharge		Action	Mag.1 [kN/m ²]	Mag.2 [kN/m ²]	Ord.x x [m]	Length l [m]	Depth z [m]
	new	change						
1	NO	NO	variable	5.00				on terrain

No.	Name
1	Q

Resistance on front face of the structure

Resistance on front face of the structure: at rest
Soil on front face of the structure - Mbushje pas murit
Soil thickness in front of structure $h = 0.40$ m
Terrain in front of structure is flat.

Earthquake

Factor of horizontal acceleration $K_h = 0.1800$
Factor of vertical acceleration $K_v = 0.0900$

Water below the GWT is restricted.

Settings of the stage of construction

Design situation : seismic

Verification No. 1 (Stage of construction 2)

Forces acting on construction

Name	F_{hor} [kN/m]	App.Pt. z [m]	F_{vert} [kN/m]	App.Pt. x [m]	Coeff. overturn.	Coeff. sliding	Coeff. stress
Weight - wall	0.00	-1.28	83.25	1.19	1.000	1.000	1.000
Earthq.- constr.	14.98	-1.28	-7.49	1.19	1.000	1.000	1.000
FF resistance	-0.65	-0.13	0.00	0.00	1.000	1.000	1.000
Active pressure	31.79	-0.82	13.49	2.00	1.000	1.000	1.000
Earthq.- act.pressure	13.92	-2.00	5.91	2.00	1.000	1.000	1.000
Q	5.90	-1.28	2.50	2.00	0.700	0.700	0.700

Verification of complete wall

Check for overturning stability

Resisting moment $M_{res} = 132.80$ kNm/m
Overturning moment $M_{ovr} = 78.25$ kNm/m

Wall for overturning is SATISFACTORY

Check for slip

Resisting horizontal force $H_{res} = 67.86$ kN/m

Active horizontal force $H_{act} = 64.17$ kN/m

Wall for slip is SATISFACTORY

Overall check - WALL is SATISFACTORY

Maximum stress in footing bottom : 86.09 kPa

Bearing capacity of foundation soil (Stage of construction 2)

Design load acting at the center of footing bottom

No.	Moment [kNm/m]	Norm. force [kN/m]	Shear Force [kN/m]	Eccentricity [-]	Stress [kPa]
1	42.36	96.91	64.17	0.219	86.09

Service load acting at the center of footing bottom

No.	Moment [kNm/m]	Norm. force [kN/m]	Shear Force [kN/m]
1	42.36	96.91	64.17

Verification of foundation soil

Eccentricity verification

Max. eccentricity of normal force $e = 0.219$

Maximum allowable eccentricity $e_{alw} = 0.333$

Eccentricity of the normal force is SATISFACTORY

Verification of bearing capacity

Max. stress at footing bottom $\sigma = 86.09$ kPa

Bearing capacity of foundation soil $R_d = 147.00$ kPa

Bearing capacity of foundation soil is SATISFACTORY

Overall verification - bearing capacity of found. soil is SATISFACTORY

Dimensioning No. 1 (Stage of construction 2)

Forces acting on construction

Name	F_{hor} [kN/m]	App.Pt. z [m]	F_{vert} [kN/m]	App.Pt. x [m]	Coeff. overturn.	Coeff. sliding	Coeff. stress
Weight - wall	0.00	-0.90	46.25	0.85	1.000	1.000	1.000
Earthq.- constr.	8.32	-0.90	-4.16	0.85	1.000	1.000	1.000
Active pressure	10.25	-0.59	4.35	1.50	1.000	1.000	1.000
Earthq.- act.pressure	4.38	-1.33	1.86	1.50	1.000	1.000	1.000
Q	3.46	-0.75	1.47	1.50	0.700	0.700	0.700

Verification of the most stressed construction joint - above the block No. 1

Check for overturning stability

Resisting moment $M_{res} = 46.63$ kNm/m

Overturning moment $M_{ovr} = 21.15$ kNm/m

Joint for overturning stability is SATISFACTORY

Check for slip

Resisting horizontal force $H_{res} = 28.48$ kN/m

Active horizontal force $H_{act} = 25.37$ kN/m

Joint for slip is SATISFACTORY

Maximum pressure on the bottom block = 47.74 kPa
 Red.Coeff. by offset of top block = 0.13
 Average value of pressure on face = 6.52 kPa
 Shear force transmitted by friction = 28.48 kN/m

Bearing capacity against transverse pressure:

Joint bear.capacity = 40.00 kN/m
 Computed stress-state = 3.26 kN/m

Transverse pressure check is SATISFACTORY

Joint btw. blocks check:

Mesh material bear.capacity = 40.00 kN/m
 Computed stress-state = 3.26 kN/m

Joint between blocks is SATISFACTORY

Slope stability analysis

Input data

Project

Settings

(input for current task)

Stability analysis

Earthquake analysis : Standard
 Verification methodology : Safety factors (ASD)

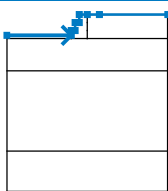
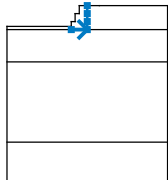

Safety factors	
Seismic design situation	
Safety factor :	$SF_s = 1.00$ [-]

Interface

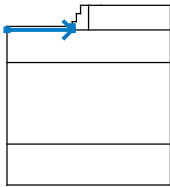
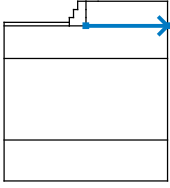
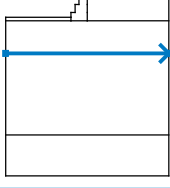
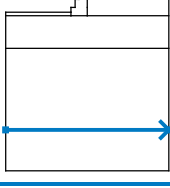

No.	Interface location	Coordinates of interface points [m]					
		x	z	x	z	x	z
1		-10.00	-2.60	-2.00	-2.60	-2.00	-2.00
		-1.50	-2.00	-1.50	-1.00	-1.00	-1.00
		-1.00	0.00	0.00	0.00	1.50	0.00
		10.00	0.00				
2		-2.00	-3.00	0.00	-3.00	0.00	-2.00
		0.00	-1.00	0.00	0.00		

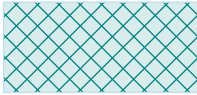
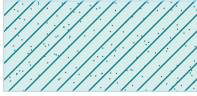
No.	Interface location	Coordinates of interface points [m]					
		x	z	x	z	x	z
3		-10.00	-3.00	-2.00	-3.00	-2.00	-2.60
4		0.00	-3.00	10.00	-3.00		
5		-10.00	-7.00	10.00	-7.00		
6		-10.00	-17.00	10.00	-17.00		

Soil parameters - effective stress state

No.	Name	Pattern	φ_{ef} [°]	c_{ef} [kPa]	γ [kN/m ³]
1	Mbushje pas murit		35.00	0.00	19.00
2	2.Perfaqesohet nga argjila e surera te perziera me zaje te rrumbullakosura , ngjyre kafe. Jane pak te ngjeshura.		33.00	14.70	18.75
3	3.Perfaqesohet nga depozitime ultrabazike, te tipit dunite, pak te serpentinizuar ngjyre te eret. Takohet ne thellesite mbi 4 m.		33.00	392.26	20.39

Soil parameters - uplift

No.	Name	Pattern	γ_{sat} [kN/m ³]	γ_s [kN/m ³]	n [-]
1	Mbushje pas murit		20.00		
2	2.Perfaqesohet nga argjila e surera te perziera me zaje te rrumbullakosura , ngjyre kafe. Jane pak te ngjeshura.		21.27		

No.	Name	Pattern	γ_{sat} [kN/m ³]	γ_s [kN/m ³]	n [-]
3	3.Perfaqesohet nga depozitime ultrabazike, te tipit dunite, pak te serpentinizuar ngjyre te eret. Takohet ne thellesite mbi 4 m.		22.11		

Soil parameters

Mbushje pas murit

Unit weight : $\gamma = 19.00 \text{ kN/m}^3$
 Stress-state : effective
 Angle of internal friction : $\varphi_{ef} = 35.00^\circ$
 Cohesion of soil : $c_{ef} = 0.00 \text{ kPa}$
 Saturated unit weight : $\gamma_{sat} = 20.00 \text{ kN/m}^3$

2.Perfaqesohet nga argjila e surera te perziera me zaje te rrumbullakosura , ngjyre kafe. Jane pak te ngjeshura.

Unit weight : $\gamma = 18.75 \text{ kN/m}^3$
 Stress-state : effective
 Angle of internal friction : $\varphi_{ef} = 33.00^\circ$
 Cohesion of soil : $c_{ef} = 14.70 \text{ kPa}$
 Saturated unit weight : $\gamma_{sat} = 21.27 \text{ kN/m}^3$

3.Perfaqesohet nga depozitime ultrabazike, te tipit dunite, pak te serpentinizuar ngjyre te eret. Takohet ne thellesite mbi 4 m.



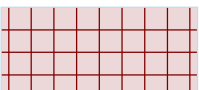

Unit weight : $\gamma = 20.39 \text{ kN/m}^3$
 Stress-state : effective
 Angle of internal friction : $\varphi_{ef} = 33.00^\circ$
 Cohesion of soil : $c_{ef} = 392.2 \text{ kPa}$
 Saturated unit weight : $\gamma_{sa} = 22.11 \text{ kN/m}^3$

Rigid bodies

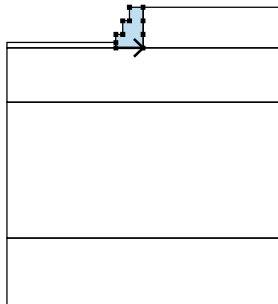
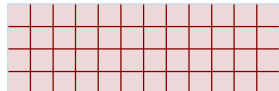
No.	Name	Sample	γ [kN/m ³]
1	Wall material		18.50

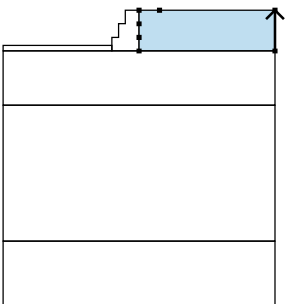
Assigning and surfaces

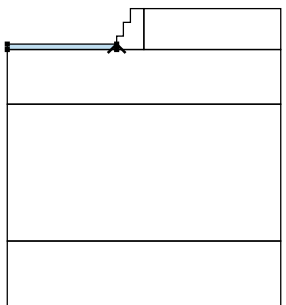
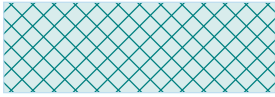
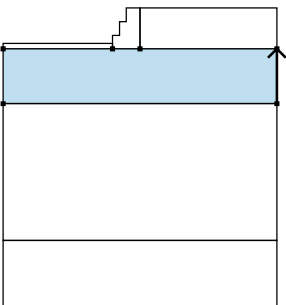
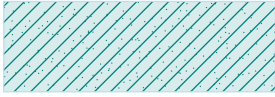
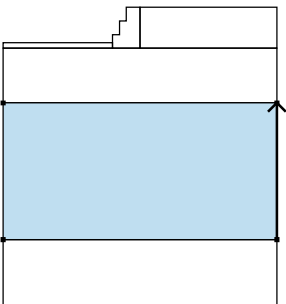
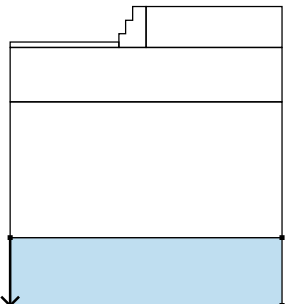
No.	Surface position	Coordinates of surface points [m]				Assigned soil
		x	z	x	z	
1		-2.00	-3.00	0.00	-3.00	Wall material 
		0.00	-2.00	0.00	-1.00	
		0.00	0.00	-1.00	0.00	
		-1.00	-1.00	-1.50	-1.00	
		-1.50	-2.00	-2.00	-2.00	
		-2.00	-2.60			

No.	Surface position	Coordinates of surface points [m]				Assigned soil	
		x	z	x	z		
2		10.00	-3.00	10.00	0.00	Mbushje pas murit	
		1.50	0.00	0.00	0.00		
		0.00	-1.00	0.00	-2.00		
		0.00	-3.00				
3		-2.00	-3.00	-2.00	-2.60	Mbushje pas murit	
		-10.00	-2.60	-10.00	-3.00		
4		10.00	-7.00	10.00	-3.00	2.Perfaqesohet nga argjila e surera te perziera me zaje te	
		0.00	-3.00	-2.00	-3.00		
		-10.00	-3.00	-10.00	-7.00		
5		10.00	-17.00	10.00	-7.00	3.Perfaqesohet nga depozitime ultrabazike, te	
		-10.00	-7.00	-10.00	-17.00		
6		-10.00	-17.00	-10.00	-22.00	3.Perfaqesohet nga depozitime ultrabazike, te	
		10.00	-22.00	10.00	-17.00		

Surcharge

No.	Type	Type of action	Location z [m]	Origin x [m]	Length l [m]	Width b [m]	Slope α [°]	Magnitude	
								q, q ₁ , f, F	q ₂ unit
1	strip	variable	on terrain	x = 0.00	l = 10.00		0.00	5.00	kN/m ²

Surcharges

Water

Water type : No water

Tensile crack

Tensile crack not inputted.

Earthquake

Horizontal seismic coefficient : $K_h = 0.18$

Vertical seismic coefficient : $K_v = 0.09$

Settings of the stage of construction

Design situation : seismic

Results (Stage of construction 1)

Analysis 1

Circular slip surface

Slip surface parameters					
Center :	x =	-1.11 [m]	Angles :	$\alpha_1 =$	-28.45 [°]
	z =	1.33 [m]		$\alpha_2 =$	72.69 [°]
Radius :	R =	4.47 [m]			

The slip surface after optimization.

Slope stability verification (Bishop)

Sum of active forces : $F_a = 94.80$ kN/m

Sum of passive forces : $F_p = 175.14$ kN/m

Sliding moment : $M_a = 423.75$ kNm/m

Resisting moment : $M_p = 782.90$ kNm/m

Factor of safety = 1.85 > 1.00

Slope stability ACCEPTABLE

Optimization of circular slip surface (Bishop)

No.	Center		Radius R [m]	FS	Verification
	x [m]	z [m]			
1	-1.01	0.95	4.08	1.88	ACCEPTABLE
2	-1.01	0.95	4.08	1.88	ACCEPTABLE
3	-1.01	0.95	4.08	1.88	ACCEPTABLE
4	-3.04	14.69	17.73	166.68	ACCEPTABLE
5	-1.23	5.06	9.55	2.70	ACCEPTABLE
6	-0.33	0.27	7.21	4.00	ACCEPTABLE
7	-4.93	0.95	4.08	8175.73	ACCEPTABLE
8	-2.59	12.29	15.51	7.35	ACCEPTABLE
9	-1.01	0.95	4.08	1.88	ACCEPTABLE
10	2.58	11.04	11.44	811.41	ACCEPTABLE
11	-2.48	9.26	12.27	186.16	ACCEPTABLE
12	-1.20	3.73	7.73	2.52	ACCEPTABLE
13	-0.42	0.36	6.00	3.52	ACCEPTABLE
14	0.09	0.10	0.51	10660.51	ACCEPTABLE
15	-3.62	0.95	4.08	662.40	ACCEPTABLE
16	-2.08	7.51	10.72	2.05	ACCEPTABLE

No.	Center		Radius R [m]	FS	Verification
	x [m]	z [m]			
17	-18.77	21.26	28.58	1456.65	ACCEPTABLE
18	-1.01	0.95	4.08	1.88	ACCEPTABLE
19	0.78	5.09	6.43	498.68	ACCEPTABLE
20	-2.05	6.05	9.07	155.23	ACCEPTABLE
21	-1.17	2.84	6.52	2.27	ACCEPTABLE
22	1.61	0.07	3.09	754.16	ACCEPTABLE
23	-0.52	0.46	5.24	3.12	ACCEPTABLE
24	-0.35	0.29	1.59	873.28	ACCEPTABLE
25	-2.75	0.95	4.08	296.29	ACCEPTABLE
26	-1.73	4.88	8.07	6.32	ACCEPTABLE
27	-19.83	29.54	36.26	776.69	ACCEPTABLE
28	-27.08	81.62	87.59	375.07	ACCEPTABLE
29	-1.01	0.95	4.08	1.88	ACCEPTABLE
30	-5.34	15.64	18.28	345.07	ACCEPTABLE
31	-0.68	4.42	6.53	341.83	ACCEPTABLE
32	-1.73	4.13	7.17	110.15	ACCEPTABLE
33	-1.14	2.23	5.71	2.15	ACCEPTABLE
34	0.64	0.47	3.51	394.21	ACCEPTABLE
35	-0.61	0.56	4.77	2.82	ACCEPTABLE
36	-3.04	2.96	5.67	364.12	ACCEPTABLE
37	-1.20	1.13	3.20	431.20	ACCEPTABLE
38	-2.17	0.95	4.08	163.29	ACCEPTABLE
39	-1.82	0.13	3.61	6.02	ACCEPTABLE
40	-1.50	3.37	6.55	1.92	ACCEPTABLE
41	0.66	0.40	3.48	389.35	ACCEPTABLE
42	-20.80	36.11	42.60	681.85	ACCEPTABLE
43	-1.01	0.95	4.08	1.88	ACCEPTABLE
44	-0.37	1.25	4.29	149.36	ACCEPTABLE
45	-2.79	6.70	9.35	281.96	ACCEPTABLE
46	-1.52	3.90	6.54	267.18	ACCEPTABLE
47	-1.51	2.97	6.02	79.33	ACCEPTABLE
48	-1.11	1.82	5.17	2.07	ACCEPTABLE
49	-0.24	0.95	4.08	111.27	ACCEPTABLE
50	-0.70	0.65	4.48	2.59	ACCEPTABLE
51	-2.37	2.29	5.10	288.46	ACCEPTABLE
52	-1.82	1.75	4.37	309.20	ACCEPTABLE
53	-1.78	0.95	4.08	100.35	ACCEPTABLE
54	-1.56	0.43	3.77	2.01	ACCEPTABLE
55	-1.34	2.48	5.64	5.50	ACCEPTABLE
56	-0.38	1.28	4.31	160.91	ACCEPTABLE
57	-21.53	40.96	47.33	498.27	ACCEPTABLE
58	-1.01	0.95	4.08	1.88	ACCEPTABLE
59	-0.66	1.33	4.34	195.15	ACCEPTABLE
60	-1.98	3.95	6.74	229.36	ACCEPTABLE
61	-1.19	2.55	5.32	263.30	ACCEPTABLE
62	-1.35	2.25	5.32	55.84	ACCEPTABLE
63	-0.10	0.05	3.58	12.28	ACCEPTABLE
64	-1.08	1.53	4.81	2.02	ACCEPTABLE
65	-0.49	0.95	4.08	72.51	ACCEPTABLE
66	-0.78	0.72	4.32	2.41	ACCEPTABLE
67	-0.87	0.30	3.33	169.75	ACCEPTABLE
68	-1.92	1.85	4.73	258.52	ACCEPTABLE

No.	Center		Radius R [m]	FS	Verification
	x [m]	z [m]			
69	-1.43	1.37	4.11	278.14	ACCEPTABLE
70	-1.53	0.95	4.08	67.22	ACCEPTABLE
71	-1.22	0.24	3.66	2.20	ACCEPTABLE
72	-1.38	0.62	3.87	5.53	ACCEPTABLE
73	-0.78	0.13	3.23	67.04	ACCEPTABLE
74	-1.23	1.93	5.08	5.43	ACCEPTABLE
75	-0.60	1.20	4.25	108.70	ACCEPTABLE
76	-22.04	44.40	50.70	596.05	ACCEPTABLE
77	-24.24	59.83	65.94	459.14	ACCEPTABLE
78	-1.01	0.95	4.08	1.88	ACCEPTABLE
79	-0.80	1.26	4.29	145.62	ACCEPTABLE
80	-1.59	2.70	5.59	223.24	ACCEPTABLE
81	-1.08	1.90	4.78	260.77	ACCEPTABLE
82	-1.24	1.79	4.88	37.13	ACCEPTABLE
83	-0.40	0.35	3.72	2.66	ACCEPTABLE
84	-1.06	1.34	4.57	1.97	ACCEPTABLE
85	-0.67	0.95	4.08	47.87	ACCEPTABLE
86	-0.85	0.79	4.22	2.26	ACCEPTABLE
87	-0.93	0.53	3.58	118.64	ACCEPTABLE
88	-1.61	1.55	4.50	242.00	ACCEPTABLE
89	-1.26	1.19	4.05	263.95	ACCEPTABLE
90	-1.35	0.95	4.08	44.54	ACCEPTABLE
91	-1.16	0.50	3.80	2.07	ACCEPTABLE
92	-0.77	0.20	3.39	20.49	ACCEPTABLE
93	-1.00	0.13	3.61	2.35	ACCEPTABLE
94	-1.26	0.74	3.94	9.04	ACCEPTABLE
95	-0.86	0.38	3.49	45.50	ACCEPTABLE
96	-1.16	1.59	4.73	5.08	ACCEPTABLE
97	-0.74	1.13	4.20	73.15	ACCEPTABLE
98	-22.39	46.79	53.05	577.49	ACCEPTABLE
99	-23.86	57.07	63.21	476.13	ACCEPTABLE
100	-22.05	46.79	53.05	476.87	ACCEPTABLE
101	-1.01	0.95	4.08	1.88	ACCEPTABLE
102	-0.88	1.18	4.23	104.31	ACCEPTABLE
103	-1.37	2.03	4.99	224.74	ACCEPTABLE
104	-1.04	1.55	4.50	231.58	ACCEPTABLE
105	-1.16	1.50	4.60	29.80	ACCEPTABLE
106	-0.61	0.55	3.83	2.40	ACCEPTABLE
107	-1.05	1.21	4.41	1.95	ACCEPTABLE
108	-0.78	0.95	4.08	34.39	ACCEPTABLE
109	-0.89	0.84	4.17	2.15	ACCEPTABLE
110	-0.96	0.67	3.75	64.33	ACCEPTABLE
111	-1.41	1.35	4.36	202.24	ACCEPTABLE
112	-1.16	1.10	4.04	250.94	ACCEPTABLE
113	-1.24	0.95	4.08	29.86	ACCEPTABLE
114	-0.85	0.25	3.58	2.26	ACCEPTABLE
115	-0.70	0.13	3.44	2.35	ACCEPTABLE
116	-1.11	0.66	3.90	2.00	ACCEPTABLE
117	-0.85	0.44	3.61	12.03	ACCEPTABLE
118	-0.99	0.37	3.73	2.20	ACCEPTABLE
119	-1.18	0.81	3.99	5.43	ACCEPTABLE
120	-0.91	0.56	3.68	24.90	ACCEPTABLE

No.	Center		Radius R [m]	FS	Verification
	x [m]	z [m]			
121	-1.11	1.37	4.51	5.39	ACCEPTABLE
122	-0.83	1.07	4.16	47.42	ACCEPTABLE
123	-22.63	48.42	54.66	553.15	ACCEPTABLE
124	-23.61	55.28	61.43	490.82	ACCEPTABLE
125	-1.01	0.95	4.08	1.88	ACCEPTABLE
126	-0.93	1.11	4.19	60.28	ACCEPTABLE
127	-1.24	1.63	4.65	148.52	ACCEPTABLE
128	-1.02	1.33	4.34	194.43	ACCEPTABLE
129	-1.11	1.31	4.42	19.28	ACCEPTABLE
130	-0.74	0.68	3.91	2.25	ACCEPTABLE
131	-1.04	1.13	4.30	1.91	ACCEPTABLE
132	-0.86	0.95	4.08	23.60	ACCEPTABLE
133	-0.93	0.87	4.13	2.07	ACCEPTABLE
134	-0.98	0.77	3.86	54.39	ACCEPTABLE
135	-1.28	1.22	4.26	111.44	ACCEPTABLE
136	-1.11	1.05	4.05	243.32	ACCEPTABLE
137	-1.16	0.95	4.08	19.30	ACCEPTABLE
138	-0.90	0.46	3.73	2.14	ACCEPTABLE
139	-0.80	0.38	3.63	2.18	ACCEPTABLE
140	-1.08	0.76	3.96	1.96	ACCEPTABLE
141	-0.90	0.60	3.76	5.42	ACCEPTABLE
142	-0.99	0.55	3.83	2.10	ACCEPTABLE
143	-1.12	0.86	4.02	5.10	ACCEPTABLE
144	-0.94	0.69	3.81	23.18	ACCEPTABLE
145	-1.08	1.22	4.36	1.86	ACCEPTABLE
146	-1.00	1.39	4.48	36.89	ACCEPTABLE
147	-1.32	1.94	4.97	115.00	ACCEPTABLE
148	-1.10	1.63	4.65	164.28	ACCEPTABLE
149	-1.18	1.60	4.72	19.43	ACCEPTABLE
150	-0.81	0.94	4.17	2.19	ACCEPTABLE
151	-1.10	1.41	4.58	1.89	ACCEPTABLE
152	-0.93	1.22	4.36	2.00	ACCEPTABLE
153	-1.00	1.13	4.40	2.03	ACCEPTABLE
154	-1.05	1.03	4.13	35.36	ACCEPTABLE
155	-1.35	1.51	4.56	86.59	ACCEPTABLE
156	-1.18	1.33	4.34	196.13	ACCEPTABLE
157	-1.23	1.22	4.36	19.42	ACCEPTABLE
158	-0.96	0.70	3.98	2.10	ACCEPTABLE
159	-0.87	0.62	3.87	2.11	ACCEPTABLE
160	-1.15	1.02	4.23	1.94	ACCEPTABLE
161	-0.97	0.86	4.02	1.94	ACCEPTABLE
162	-1.06	0.79	4.08	2.07	ACCEPTABLE
163	-1.19	1.12	4.30	1.89	ACCEPTABLE
164	-1.01	0.95	4.08	1.88	ACCEPTABLE
165	-1.14	1.51	4.65	5.40	ACCEPTABLE
166	-0.96	1.31	4.42	12.83	ACCEPTABLE
167	-22.79	49.53	55.75	548.54	ACCEPTABLE
168	-23.45	54.10	60.26	509.80	ACCEPTABLE
169	-22.64	49.53	55.75	501.69	ACCEPTABLE
170	-1.08	1.22	4.36	1.86	ACCEPTABLE
171	-1.03	1.34	4.44	31.20	ACCEPTABLE
172	-1.23	1.69	4.75	65.13	ACCEPTABLE

No.	Center		Radius R [m]	FS	Verification
	x [m]	z [m]			
173	-1.09	1.48	4.54	79.38	ACCEPTABLE
174	-1.15	1.47	4.60	12.40	ACCEPTABLE
175	-0.90	1.03	4.23	2.08	ACCEPTABLE
176	-1.10	1.34	4.51	1.89	ACCEPTABLE
177	-0.98	1.22	4.36	1.98	ACCEPTABLE
178	-1.02	1.16	4.39	1.99	ACCEPTABLE
179	-1.06	1.09	4.21	12.32	ACCEPTABLE
180	-1.26	1.41	4.49	54.72	ACCEPTABLE
181	-1.14	1.29	4.34	89.47	ACCEPTABLE
182	-1.18	1.22	4.36	15.90	ACCEPTABLE
183	-1.00	0.87	4.10	2.02	ACCEPTABLE
184	-0.94	0.81	4.02	2.02	ACCEPTABLE
185	-1.13	1.09	4.27	1.90	ACCEPTABLE
186	-1.01	0.98	4.13	1.91	ACCEPTABLE
187	-1.06	0.92	4.17	2.01	ACCEPTABLE
188	-1.16	1.16	4.32	5.41	ACCEPTABLE
189	-1.04	1.04	4.17	5.39	ACCEPTABLE
190	-1.12	1.41	4.55	5.40	ACCEPTABLE
191	-1.00	1.28	4.40	9.47	ACCEPTABLE
192	-23.72	54.93	61.08	554.59	ACCEPTABLE
193	-24.17	58.13	64.26	507.70	ACCEPTABLE
194	-23.62	54.93	61.08	516.70	ACCEPTABLE
195	-1.08	1.22	4.36	1.86	ACCEPTABLE
196	-1.05	1.30	4.41	17.44	ACCEPTABLE
197	-1.18	1.52	4.61	33.44	ACCEPTABLE
198	-1.08	1.39	4.48	36.73	ACCEPTABLE
199	-1.13	1.39	4.52	8.90	ACCEPTABLE
200	-0.96	1.09	4.28	2.06	ACCEPTABLE
201	-1.09	1.30	4.46	1.87	ACCEPTABLE
202	-1.01	1.22	4.36	1.97	ACCEPTABLE
203	-1.04	1.18	4.38	1.94	ACCEPTABLE
204	-1.07	1.14	4.26	12.33	ACCEPTABLE
205	-1.20	1.35	4.45	36.95	ACCEPTABLE
206	-1.12	1.27	4.35	47.06	ACCEPTABLE
207	-1.15	1.22	4.36	12.40	ACCEPTABLE
208	-1.02	0.98	4.18	1.97	ACCEPTABLE
209	-0.98	0.94	4.13	1.97	ACCEPTABLE
210	-1.11	1.13	4.30	1.89	ACCEPTABLE
211	-1.03	1.06	4.21	1.90	ACCEPTABLE
212	-1.06	1.02	4.23	1.96	ACCEPTABLE
213	-1.13	1.18	4.33	5.40	ACCEPTABLE
214	-1.05	1.10	4.23	5.39	ACCEPTABLE
215	-1.11	1.35	4.49	1.85	ACCEPTABLE
216	-1.08	1.43	4.55	9.68	ACCEPTABLE
217	-1.21	1.66	4.75	36.96	ACCEPTABLE
218	-1.11	1.53	4.62	29.01	ACCEPTABLE
219	-1.16	1.52	4.65	12.42	ACCEPTABLE
220	-0.99	1.22	4.40	2.03	ACCEPTABLE
221	-1.12	1.43	4.59	1.87	ACCEPTABLE
222	-1.04	1.35	4.49	1.95	ACCEPTABLE
223	-1.07	1.31	4.50	1.93	ACCEPTABLE
224	-1.10	1.26	4.39	12.39	ACCEPTABLE

No.	Center		Radius R [m]	FS	Verification
	x [m]	z [m]			
225	-1.23	1.48	4.58	37.04	ACCEPTABLE
226	-1.15	1.40	4.48	43.00	ACCEPTABLE
227	-1.18	1.35	4.49	8.91	ACCEPTABLE
228	-1.05	1.10	4.30	1.95	ACCEPTABLE
229	-1.01	1.06	4.25	1.96	ACCEPTABLE
230	-1.14	1.26	4.43	1.88	ACCEPTABLE
231	-1.06	1.18	4.33	1.88	ACCEPTABLE
232	-1.09	1.14	4.35	1.95	ACCEPTABLE
233	-1.16	1.31	4.46	5.40	ACCEPTABLE
234	-1.08	1.22	4.36	1.86	ACCEPTABLE
235	-1.14	1.48	4.62	5.39	ACCEPTABLE
236	-1.06	1.39	4.52	1.93	ACCEPTABLE
237	-23.80	55.45	61.61	527.89	ACCEPTABLE
238	-24.10	57.59	63.72	519.33	ACCEPTABLE
239	-23.73	55.45	61.61	509.31	ACCEPTABLE
240	-1.11	1.35	4.49	1.85	ACCEPTABLE
241	-1.09	1.41	4.53	12.29	ACCEPTABLE
242	-1.18	1.56	4.66	29.85	ACCEPTABLE
243	-1.11	1.47	4.57	28.96	ACCEPTABLE
244	-1.14	1.46	4.60	5.39	ACCEPTABLE
245	-1.03	1.26	4.43	1.92	ACCEPTABLE
246	-1.12	1.41	4.56	1.86	ACCEPTABLE
247	-1.06	1.35	4.49	1.95	ACCEPTABLE
248	-1.08	1.32	4.50	1.91	ACCEPTABLE
249	-1.10	1.29	4.42	8.89	ACCEPTABLE
250	-1.19	1.44	4.55	29.98	ACCEPTABLE
251	-1.14	1.38	4.48	26.24	ACCEPTABLE
252	-1.16	1.35	4.49	8.92	ACCEPTABLE
253	-1.07	1.18	4.36	1.92	ACCEPTABLE
254	-1.05	1.15	4.33	1.92	ACCEPTABLE
255	-1.13	1.29	4.45	1.87	ACCEPTABLE
256	-1.08	1.24	4.38	1.87	ACCEPTABLE
257	-1.10	1.21	4.40	1.92	ACCEPTABLE
258	-1.14	1.32	4.47	5.39	ACCEPTABLE
259	-1.09	1.27	4.40	8.88	ACCEPTABLE
260	-1.13	1.44	4.58	5.39	ACCEPTABLE
261	-1.08	1.38	4.51	5.37	ACCEPTABLE
262	-24.19	57.85	63.98	524.62	ACCEPTABLE
263	-24.40	59.30	65.42	515.56	ACCEPTABLE
264	-24.15	57.85	63.98	511.08	ACCEPTABLE
265	-1.11	1.35	4.49	1.85	ACCEPTABLE
266	-1.09	1.39	4.52	5.37	ACCEPTABLE
267	-1.15	1.49	4.60	22.83	ACCEPTABLE
268	-1.11	1.43	4.54	19.21	ACCEPTABLE
269	-1.13	1.43	4.56	8.92	ACCEPTABLE
270	-1.06	1.29	4.45	1.89	ACCEPTABLE
271	-1.12	1.39	4.54	1.86	ACCEPTABLE
272	-1.08	1.35	4.49	1.86	ACCEPTABLE
273	-1.09	1.33	4.50	1.89	ACCEPTABLE
274	-1.10	1.31	4.44	8.89	ACCEPTABLE
275	-1.16	1.41	4.53	19.41	ACCEPTABLE
276	-1.13	1.37	4.49	15.84	ACCEPTABLE

No.	Center		Radius R [m]	FS	Verification
	x [m]	z [m]			
277	-1.14	1.35	4.49	5.39	ACCEPTABLE
278	-1.08	1.24	4.40	1.89	ACCEPTABLE
279	-1.07	1.22	4.38	1.89	ACCEPTABLE
280	-1.12	1.31	4.46	1.86	ACCEPTABLE
281	-1.09	1.27	4.42	1.87	ACCEPTABLE
282	-1.10	1.26	4.43	1.89	ACCEPTABLE
283	-1.13	1.33	4.48	1.86	ACCEPTABLE
284	-1.10	1.29	4.43	1.85	ACCEPTABLE
285	-1.12	1.41	4.55	5.40	ACCEPTABLE
286	-1.09	1.37	4.50	5.37	ACCEPTABLE
287	-24.23	58.09	64.22	524.74	ACCEPTABLE
288	-24.36	59.06	65.18	389.66	ACCEPTABLE
289	-24.20	58.09	64.22	514.68	ACCEPTABLE
290	-1.11	1.35	4.49	1.85	ACCEPTABLE
291	-1.10	1.38	4.51	8.90	ACCEPTABLE
292	-1.14	1.44	4.57	8.91	ACCEPTABLE
293	-1.11	1.40	4.53	8.91	ACCEPTABLE
294	-1.12	1.40	4.54	5.40	ACCEPTABLE
295	-1.07	1.31	4.46	1.87	ACCEPTABLE
296	-1.11	1.38	4.52	5.39	ACCEPTABLE
297	-1.09	1.35	4.49	1.86	ACCEPTABLE
298	-1.10	1.34	4.49	1.87	ACCEPTABLE
299	-1.11	1.32	4.46	5.40	ACCEPTABLE
300	-1.15	1.39	4.52	12.43	ACCEPTABLE
301	-1.12	1.36	4.49	8.90	ACCEPTABLE
302	-1.13	1.35	4.49	5.40	ACCEPTABLE
303	-1.09	1.27	4.43	1.88	ACCEPTABLE
304	-1.08	1.26	4.42	1.89	ACCEPTABLE
305	-1.12	1.32	4.47	1.86	ACCEPTABLE
306	-1.10	1.30	4.44	1.85	ACCEPTABLE
307	-1.10	1.29	4.45	1.88	ACCEPTABLE
308	-1.12	1.34	4.48	5.40	ACCEPTABLE
309	-1.10	1.31	4.45	1.85	ACCEPTABLE
310	-1.12	1.39	4.53	5.39	ACCEPTABLE
311	-1.09	1.36	4.50	1.85	ACCEPTABLE
312	-24.25	58.25	64.37	529.12	ACCEPTABLE
313	-24.34	58.90	65.02	516.30	ACCEPTABLE
314	-24.23	58.25	64.37	525.52	ACCEPTABLE
315	-1.11	1.35	4.49	1.85	ACCEPTABLE
316	-1.10	1.37	4.50	8.90	ACCEPTABLE
317	-1.13	1.41	4.54	8.92	ACCEPTABLE
318	-1.11	1.38	4.51	8.90	ACCEPTABLE
319	-1.12	1.38	4.52	5.39	ACCEPTABLE
320	-1.09	1.32	4.47	1.87	ACCEPTABLE
321	-1.11	1.37	4.51	5.39	ACCEPTABLE
322	-1.10	1.35	4.49	1.85	ACCEPTABLE
323	-1.10	1.34	4.49	1.87	ACCEPTABLE
324	-1.11	1.33	4.47	1.85	ACCEPTABLE
325	-1.10	1.35	4.48	8.90	ACCEPTABLE
326	-1.13	1.39	4.52	8.90	ACCEPTABLE
327	-1.11	1.36	4.49	8.90	ACCEPTABLE
328	-1.12	1.36	4.50	8.91	ACCEPTABLE

No.	Center		Radius	FS	Verification
	x [m]	z [m]	R [m]		
329	-1.09	1.30	4.45	1.87	ACCEPTABLE
330	-1.11	1.35	4.49	1.85	ACCEPTABLE
331	-1.10	1.33	4.47	1.85	ACCEPTABLE
332	-1.10	1.32	4.47	1.86	ACCEPTABLE
333	-1.11	1.31	4.45	5.40	ACCEPTABLE
334	-1.13	1.36	4.49	12.42	ACCEPTABLE
335	-1.12	1.34	4.47	12.41	ACCEPTABLE
336	-1.12	1.33	4.47	5.39	ACCEPTABLE
337	-1.10	1.28	4.43	1.87	ACCEPTABLE
338	-1.09	1.27	4.42	1.87	ACCEPTABLE
339	-1.12	1.31	4.46	1.86	ACCEPTABLE
340	-1.10	1.30	4.44	1.85	ACCEPTABLE
341	-1.11	1.29	4.44	1.87	ACCEPTABLE
342	-1.12	1.32	4.46	5.40	ACCEPTABLE
343	-1.10	1.30	4.44	1.85	ACCEPTABLE
344	-1.12	1.36	4.50	8.91	ACCEPTABLE
345	-1.10	1.34	4.48	1.85	ACCEPTABLE
346	-24.27	58.36	64.48	528.10	ACCEPTABLE
347	-24.33	58.79	64.91	519.84	ACCEPTABLE
348	-24.25	58.36	64.48	526.04	ACCEPTABLE
349	-1.11	1.33	4.47	1.85	ACCEPTABLE

Hartoi
Per Konsulentin
“Gjeokosult & Co” sh.p.k.
Ing. Rroland Hajro