

ARCHITECTURE PROJECT

Project:

Establishment of the Educational Infrastructure of the Franco-Albanian Lyceum of Sciences and Innovation, Municipality of Korça

Students's dormitory

Phase: Building permit

Client: ALBANIAN DEVELOPMENT FUND

Prepered:

ARCHISPACE + iRI + SPHAERA

2026

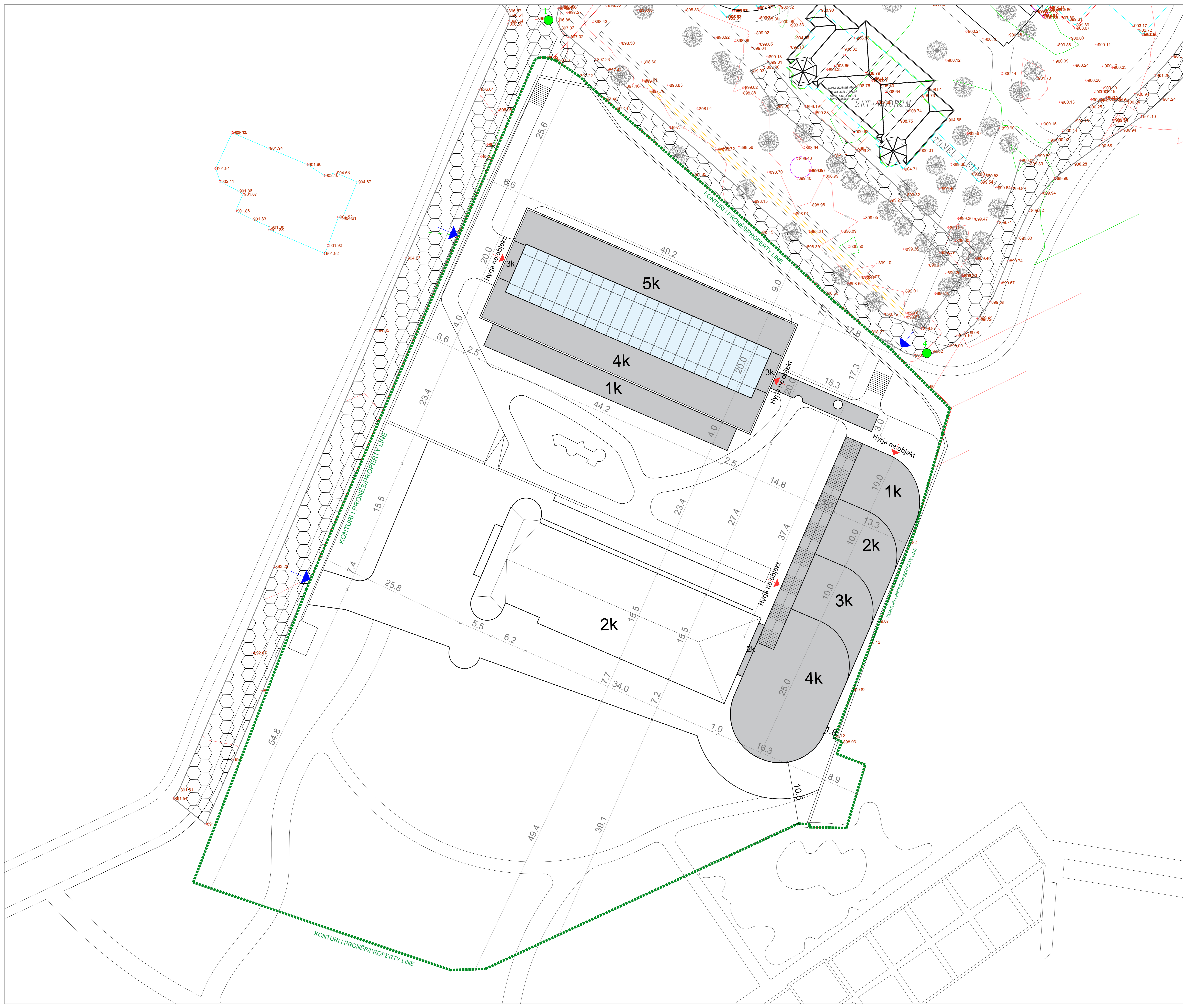

- LEGJENDA / LEGEND:**
- - - - - KUFIRI I PRONES / PROPERTY LINE
 - HYRJE NE OBJEKT / ENTRANCE
 - NJJOLLA E OBJEKTIT / BUILDING
 - HYRJE NE PRONE / PROPERTY ENTRANCE
 - NJJOLLA E OBJEKTIT EKZISTUES / EXISTING BUILDING

PROJEKTI / Project:
 Ngritja e Infrastrukturës Arsimore të Liceut Franko-Shqiptar të Shkencave dhe Inovacionit, Bashkia Korçë / Establishment of the Educational Infrastructure of the Franco-Albanian Lyceum of Sciences and Innovation, Municipality of Korça

Klienti: FONDI SHQIPTAR I ZHVILLIMIT
 Client: ALBANIAN DEVELOPMENT FUND

iRI <small>Local Architecture Office Studio Lokale Arkitekturë Gjeoçajt</small>	N.6844	Firma / Signature: Lexoj dhe aprovj / I read and approve.
ARCHISPACE <small>Local Architecture Office Studio Lokale Arkitekturë Plan Përfaqësues</small>	N.6732/14	Firma / Signature: Lexoj dhe aprovj / I read and approve.
SPHAERA <small>Local Architecture Office Studio Lokale Arkitekturë Aktor Topografik</small>	N.4654/14	Firma / Signature: Lexoj dhe aprovj / I read and approve.
LORENC BEGAJ AVE CONSULTING <small>Consultor i Shkencave Studio Konsultive Ing. Arben Dervishi Ing. Erind Dushku Ing. Mita Hoxha</small>	K.2138/2 N.5628/12	Firma / Signature: Lexoj dhe aprovj / I read and approve.
BURHAN TURKESHI ERMIR GJOKA <small>Hydro-Mechanical Engineering Inzhineri Hidro-Mekanik dhe MZ</small>	K.1873/4 M.1174/2	Firma / Signature: Lexoj dhe aprovj / I read and approve.
BASHKIM SHAHINAJ BESART DALLIU <small>Electrical Engineering Inzhineri Elektrik</small>	E.0185/6 E.1412/2	Firma / Signature: Lexoj dhe aprovj / I read and approve.

ALL DIMENSIONS HAVE TO BE VERIFIED BY THE CONTRACTOR ON THE CONSTRUCTION SITE.
 TË GJITHA DIMENSIONET DUHET TË VERIFIKOHEN NGA KONTRAKTORI NË VËND.
 IMPORTANT: These drawings are property of iRI. Rruga DERSUVISH HIMA, nr 8 kat i pare - 1001 TIRANA. Copy, multiplication or distribution in whole or in part of these plans (or any part of it) without written permission of iRI is prohibited.
 E RËNDËSISHME: Këto vizatime janë pronë e iRI. Rruga DERSUVISH HIMA, nr 8 kat i parë - 1001 TIRANË. Kopimi, shumëlirimi apo shpërndarja e këtyre vizatimeve (apo pjesëve të tyre) pa lejen me shkrim të iRI-së është e ndaluar.

Issuer: A	plan number: A.00.1	TITULLI / Title: PLANVENDOSJE / SITE PLAN	
Faza: LN	data: 2026	shkalla e vizatimit: 1:200	formati: A0

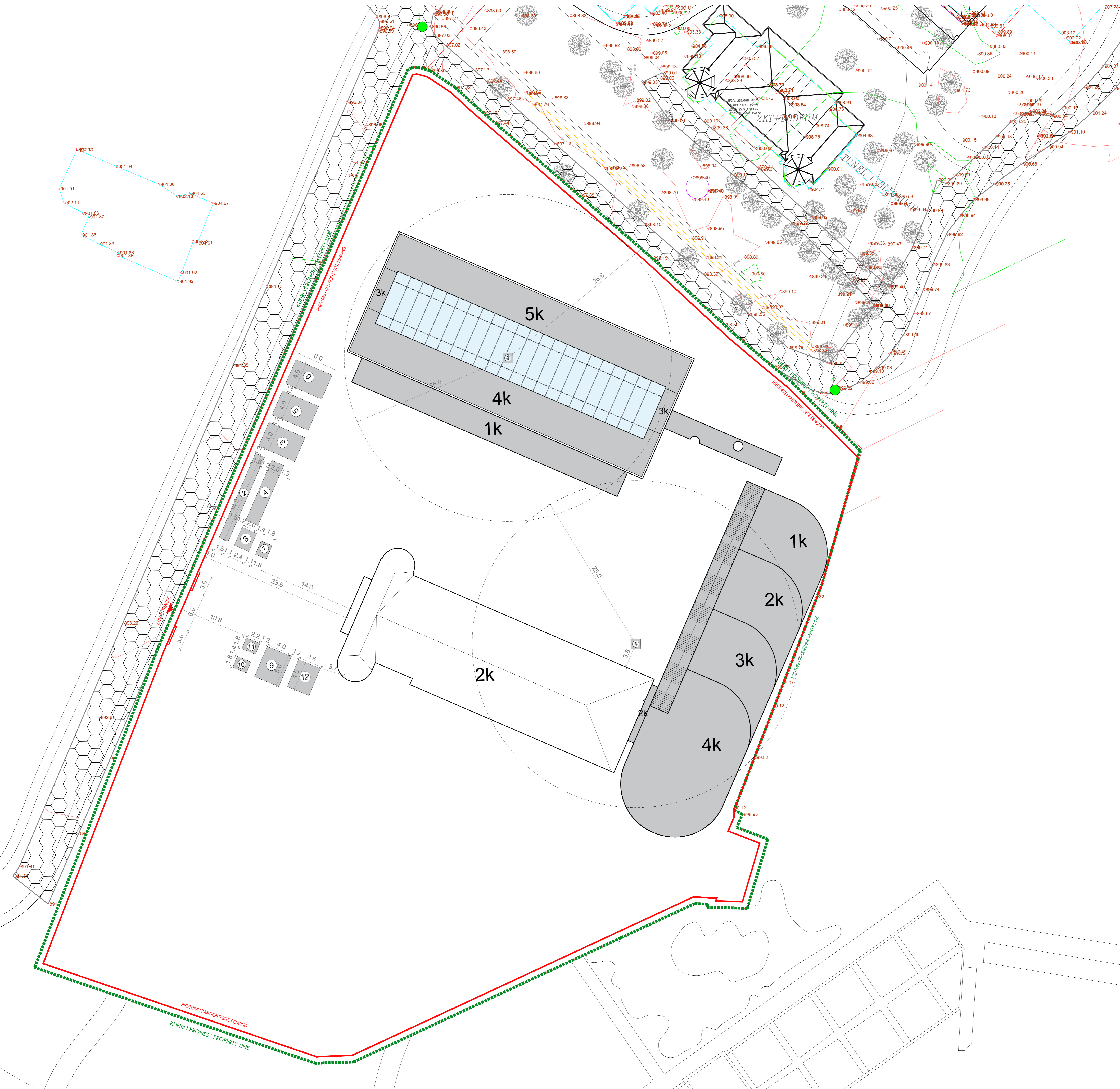

LEGJENDA/ Legenda:

- konturi i pronës/ property line
- rrethimi i kantierit/ site fencing
- ① vinçi/ crane
- ② shesh për hekurin/ space for the iron
- ③ shesh për tullat/ space for the bricks
- ④ shesh për pllakën/ space for the tiles
- ⑤ shesh për llaçin/ space for the mortar
- ⑥ shesh për çimenton/ space for the cement
- ⑦ grumbullim mbeturinash/ space for the trash
- ⑧ depozita/ deposit
- ⑨ zyra/ office
- ⑩ roja/ security
- ⑪ tualet/ toilet
- ⑫ garderoba/ changig room

DETAJ I RRETHIMIT TE KANTIERIT/ SITE FENCING DETAIL

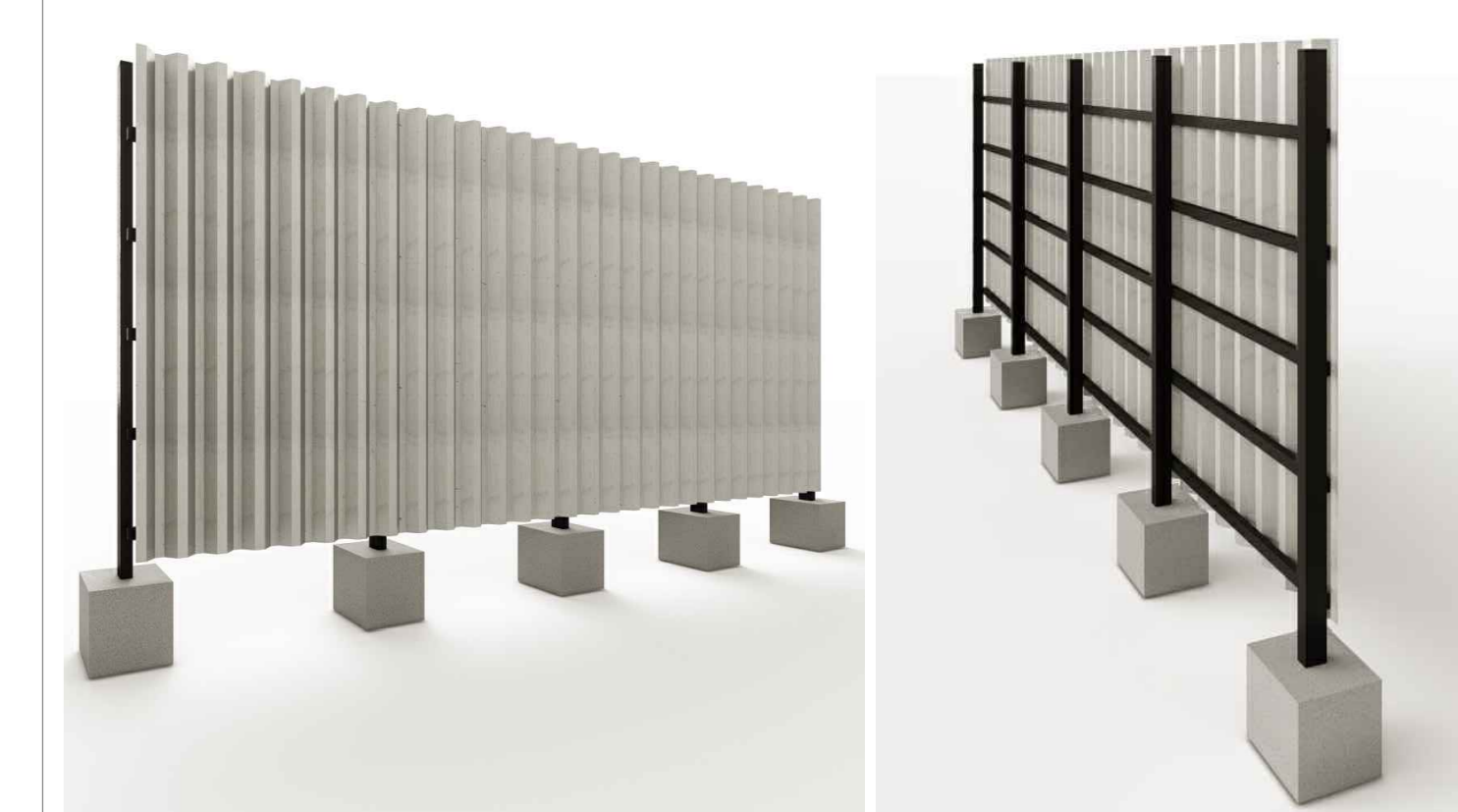
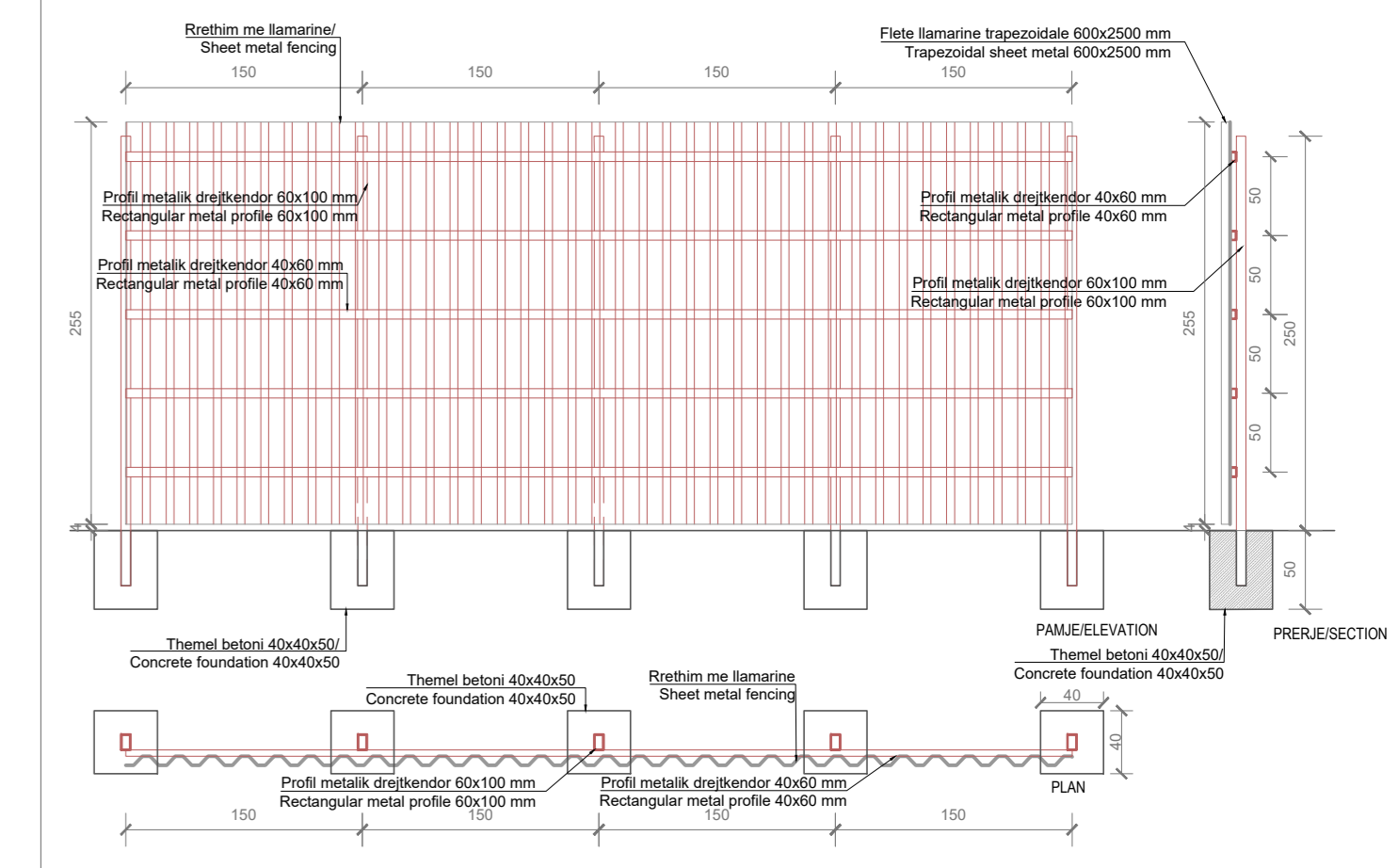

PROJEKTI / Project:
 Ngritja e Infrastrukturës Arsimore të Liceut Franko-Shqiptar të Shkencave dhe Inovacionit, Bashkia Korçë / Establishment of the Educational Infrastructure of the Franco-Albanian Lyceum of Sciences and Innovation, Municipality of Korça

Klienti: FONDI SHQIPTAR I ZHVILLIMIT
 Client: ALBANIAN DEVELOPMENT FUND

iRI Local Architecture Office Studio Luljeta Architects Shkup, North Macedonia	N.6844	Firma / Signature: Lexoj dhe aprovuj / I read and approve.
ARCHISPACE Local Architecture Office Studio Luljeta Architects Shkup, North Macedonia	N.6732/14	Firma / Signature: Lexoj dhe aprovuj / I read and approve.
SPHAERA Local Architecture Office Studio Luljeta Architects Shkup, North Macedonia	N.4654/14	Firma / Signature: Lexoj dhe aprovuj / I read and approve.
LORENC BEGAJ AVE CONSULTING Construction Studio Studio Korçezore Rr. Adem Demiri 100, Shkup, North Macedonia	K.2138/2 N.5628/12	Firma / Signature: Lexoj dhe aprovuj / I read and approve.
BURHAN TURKESHI ERMIR GJOKA Hydro-Mechanical Engineering Inshtrueshë Inzhinierë dhe Arhitektë	K.1873/4 M.1174/2	Firma / Signature: Lexoj dhe aprovuj / I read and approve.
BASHKIM SHAHINAJ BESART DALLIU Electrical Engineering Inshtrueshë Inzhinierë dhe Arhitektë	E.0185/6 E.1412/2	Firma / Signature: Lexoj dhe aprovuj / I read and approve.

ISSUER A	PLAN NUMBER A.00.2	TITULLI / Title: PLANI I KANTIERIT / SITE WORKS PLAN
Faza: LN	data: 2026	shkalla e vizatimit: 1:200
		formati: A0

ALL DIMENSIONS HAVE TO BE VERIFIED BY THE CONTRACTOR ON THE CONSTRUCTION SITE.
 SHËNIMET: Të gjitha dimensionet duhet të verifikohen nga kontraktori në vend.
 EMBLËME/SHËNIM: Këtu ruhet gjendja e origjinalit të projektit dhe të të gjitha dokumenteve të kësaj pune - 100% TRAZA. Copy, multiplication or distribution without written permission of these plans or any part of it without written permission of iRI is prohibited.

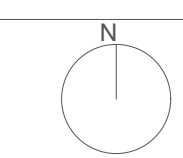

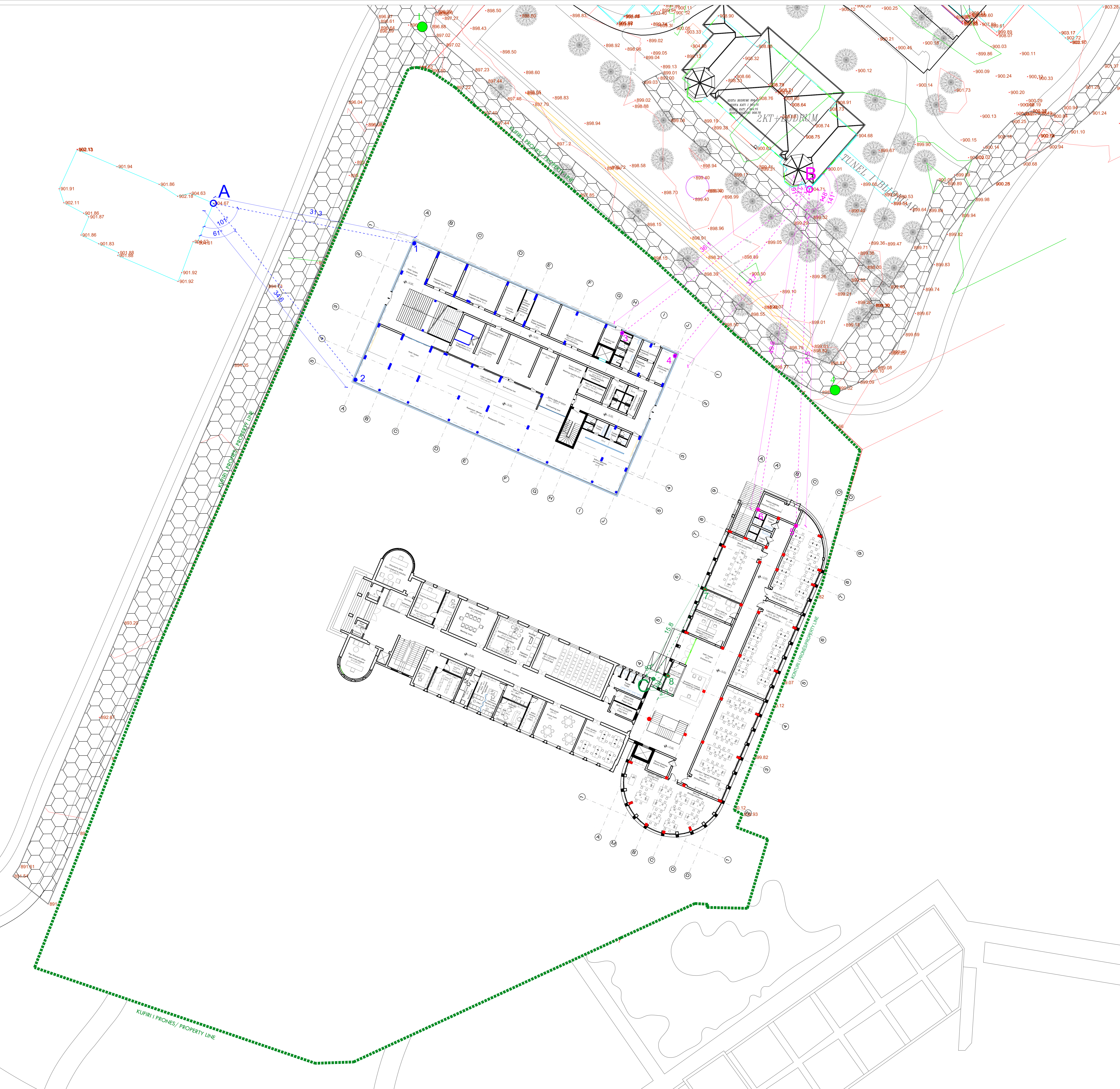

Duke u nisur nga pika **A** e godines ne veriperendim te sitit, 101^o me faqen juglindore te saj, ne distancan 31.3 m perfitojme piken **1**. Ne te njeten menyre duke u nisur nga pika **A**, 61^o me faqen juglindore te saj, ne distancan 34.6 m perfitojme piken **2**.

Duke bashkuar pikat **1** dhe **2** perfitojme aksin (A). Sipas permasave te projektit, duke vazhduar ne menyre paralele me asksin (A) perfitojme akset (B)-(J).

Duke u nisur nga pika **B** e godines ne verilindje te sitit, 91^o me faqen jugperendim te saj, ne distancan 36.1 m perfitojme piken **3**. Ne te njeten menyre duke u nisur nga pika **B**, 77^o me faqen jugperendim te saj, ne distancan 32.7 m perfitojme piken **4**.

Duke bashkuar pikat **3** dhe **4** perfitojme aksin (1). Sipas permasave te projektit, duke vazhduar ne menyre paralele me asksin (1) perfitojme akset (2)-(5).

Duke u nisur nga pika **B** e godines ne verilindje te sitit, 141^o me faqen juglindore te saj, ne distancan 51.5 m perfitojme piken **5**. Ne te njeten menyre duke u nisur nga pika **B**, 148^o me faqen juglindore te saj, ne distancan 49.6 m perfitojme piken **6**.

Duke bashkuar pikat **5** dhe **6** perfitojme aksin (9). Sipas permasave te projektit, duke vazhduar ne menyre paralele me asksin (9) perfitojme akset (1)-(8).

Duke u nisur nga pika **C** e godines ne brendesi te sitit, 97^o me faqen veriperendim te saj, ne distancan 15.8 m perfitojme piken **7**. Ne te njeten menyre duke u nisur nga pika **C**, 126^o me faqen juglindore te saj, ne distancan 2.3 m perfitojme piken **8**.

Duke bashkuar pikat **7** dhe **8** perfitojme aksin (A). Sipas permasave te projektit, duke vazhduar ne menyre paralele me asksin (A) perfitojme akset (A')-(D).

Starting from point **A** of the building in the northwest of the site, 101^o with its southeast side, at a distance of 31.3 m, we obtain point **1**. In the same way, starting from point **A**, 61^o with its southeast side, at a distance of 34.6 m, we obtain point **2**.

By joining points **1** and **2**, we obtain axis (A). According to the dimensions of the project, continuing parallel to axis (A), we obtain axes (B)-(J).

Starting from point **B** of the building in the northeast of the site, 91^o with its southwest side, at a distance of 36.1 m we obtain point **3**. In the same way starting from point **B**, 77^o with its southwest side, at a distance of 32.7 m we obtain point **4**.

By joining points **3** and **4** we obtain axis (1). According to the dimensions of the project, continuing parallel to axis (1) we obtain axes (2)-(5).

Starting from point **B** of the building in the northeast of the site, 141^o with its southeast side, at a distance of 51.5 m we obtain point **5**. In the same way starting from point **B**, 148^o with its southeast side, at a distance of 49.6 m we obtain point **6**.

By joining points **5** and **6** we obtain axis (9). According to the dimensions of the project, continuing parallel to axis (9) we obtain axes (1)-(8).

Starting from point **C** of the building inside the site, 97^o with its northwest side, at a distance of 15.8 m we obtain point **7**. In the same way starting from point **C**, 126^o with its southeast side, at a distance of 2.3 m we obtain point **8**.

By joining points **7** and **8** we obtain axis (A). According to the dimensions of the project, continuing parallel to axis (A) we obtain axes (A')-(D).

PROJEKTI / Project:
Ngritja e Infrastrukturës Arsimore të Liceut Franko-Shqiptar të Shkencave dhe Inovacionit, Bashkia Korçë / Establishment of the Educational Infrastructure of the Franco-Albanian Lyceum of Sciences and Innovation, Municipality of Korça

Klienti: FONDI SHQIPTAR I ZHVILLIMIT
Client: ALBANIAN DEVELOPMENT FUND

iRI Local Architecture Office Studio Lulzim Arbeni Shkup	N.6844	Firma / Signature: Lexoj dhe aprovaj / I read and approve.
ARCHISPACE Local Architecture Office Studio Lulzim Arbeni Shkup	N.6732/14	Firma / Signature: Lexoj dhe aprovaj / I read and approve.
SPHAERA Local Architecture Office Studio Lulzim Arbeni Shkup	N.4654/14	Firma / Signature: Lexoj dhe aprovaj / I read and approve.
LORENC BEGAJ AVE CONSULTING Construction Studio Studio Korçezore Pj. Arben Demiri Bj. Erta Durrës Tj. Inshtruar	K.2138/2 N.5628/12	Firma / Signature: Lexoj dhe aprovaj / I read and approve.
BURHAN TURKESHI ERMIR GJOKA Hydro-Mechanical Engineering Inshtruar Korçezore dhe TIRË	K.1873/4 M.1174/2	Firma / Signature: Lexoj dhe aprovaj / I read and approve.
BASHKIM SHAHINAJ BESART DALLIU Electrical Engineering Inshtruar Korçezore	E.0185/6 E.1412/2	Firma / Signature: Lexoj dhe aprovaj / I read and approve.

ALL DIMENSIONS HAVE TO BE VERIFIED BY THE CONTRACTOR ON THE CONSTRUCTION SITE.
SHËNOTIM: Të gjitha dimensionet duhet të verifikohen nga kontraktori në vend.
E-MAIL: EMBASE@SHKNCHE.KORCE.GOV.AL
pajisje - 1001 TRANA. Copy, multiplication or distribution without written permission of these plans or any part of it without written permission of iRI is prohibited.

Issuer: A	plan number: A.00.3	TITULLI / Title: PLANI I PIKETIMIT/ AXES PLAN ON SITE
Faza: LN	data: 2026	shkalla e vizatimit: 1:200
		formati: A0



Legjende/ Legend

- Kufi prone/ Property Line
- peme ekzistuese/ existing tree
- ➔ HYRJE NE PRONE / PROPERTY ENTRANCE
- PEME QE HIQEN / REMOVED TREES
- MURE SISTEIMI QE PRISHEN/ REMOVED LANDSCAPE WALLS
- GERMIM PER HIDROIZOLIMIN E THEMELEVE/ ESCAVATION FOR FOUNDATION INSULATION

PROJEKTI / Project:
 Ngritja e Infrastrukturës Arsimore të Liceut Franko-Shqiptar të Shkencave dhe Inovacionit, Bashkia Korçë / Establishment of the Educational Infrastructure of the Franco-Albanian Lyceum of Sciences and Innovation, Municipality of Korça

Klienti: FONDI SHQIPTAR I ZHVILLIMIT
 Client: ALBANIAN DEVELOPMENT FUND

iRI <small>Local Architecture Office Studio Lokale Arkitekture Georgjani</small>	N.6844	Firma / Signature: Lexoj dhe aprovoj / I read and approve.
ARCHISPACE <small>Local Architecture Office Studio Lokale Arkitekture Rex Pota</small>	N.6732/14	Firma / Signature: Lexoj dhe aprovoj / I read and approve.
SPHAERA <small>Local Architecture Office Studio Lokale Arkitekture Ajet Topani</small>	N.4654/14	Firma / Signature: Lexoj dhe aprovoj / I read and approve.
LORENC BEGAJ AVE CONSULTING <small>Consultor/ Shkuror Studio Konsultime Ing. Arben Dervishi Ing. Erind Sulliu Ing. Na Hoxha</small>	K.2138/2 N.5628/12	Firma / Signature: Lexoj dhe aprovoj / I read and approve.
BURHAN TURKESHI ERMIR GJOKA <small>Hydro-Mechanical Engineering Inzhineri Hidro-Mekanik dhe MZ</small>	K.1873/4 M.1174/2	Firma / Signature: Lexoj dhe aprovoj / I read and approve.
BASHKIM SHAHINAJ BESART DALLIU <small>Electrical Engineering Inzheneri Elektrik</small>	E.0185/6 E.1412/2	Firma / Signature: Lexoj dhe aprovoj / I read and approve.





ALL DIMENSIONS HAVE TO BE VERIFIED BY THE CONTRACTOR ON THE CONSTRUCTION SITE.
 IMPORTANT: These drawings are property of iRI, Rruga DERSVISH HIMA, nr 8 kati i pare - 1001 TIRANA, Copy, multiplication or distribution in whatever parties of these plans (or any part of it) without written permission of iRI is prohibited.

TË GJITHA DIMENSIONET DUHET TË VERIFIKOHEN NGA KONTRAKTORI NË VËND.
 E RËNDËSISHME: Këto vizatime janë pronë e iRI, Rruga DERSVISH HIMA, nr 8 kati i parë - 1001 TIRANË, Kopimi, shumëllojshmëri apo shpërndarje e këtyre vizatimeve (apo pjesëve të tyre) pa lejen me shkrim të iRI është e ndaluar.

Issuer A	plan number: A.00.4	TITULLI / Title: NDRYSHIME NE SISTEMIN EKZISTUES/ CHANGES IN CURRENT LANDSCAPE PLAN
Faza: LN	data: 2026	shkalla e vizatimit: 1:200
		formati: A0

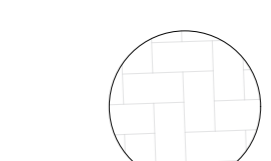
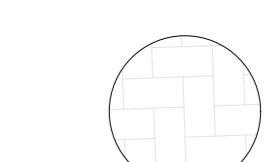
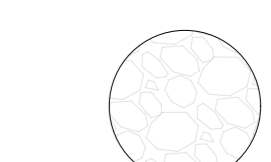
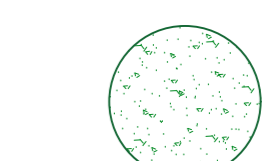
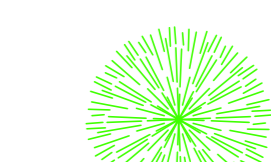

Legjende/ Legend

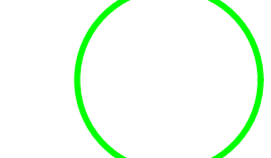
-  Kufi prone/ Property Line
-  Shtim me pllake (ekzistues)/ Tile pavement (existing)
-  Shtim me pllake 385 m²/ Tile pavement 385 m²
-  Shtim me zhavorr 1141 m²/ Gravel pavement 1141 m²
-  Siperfaqe gjelberimi 1578 m²/ Surface planted with grass 1578 m²
-  peme ekzistuese/ existing tree
-  ndricues gjelberimi te ulet/ low green lighting
-  stol/ stool
-  kosh mbeturinash/ trash can
-  HYRJE NE PRONE / PROPERTY ENTRANCE
-  PEME QE RIMBILLEN / REPLANTED TREES

PROJEKTI / Project:
 Ngritja e Infrastrukturës Arsimore të Liceut Franko-Shqiptar të Shkencave dhe Inovacionit, Bashkia Korçë / Establishment of the Educational Infrastructure of the Franco-Albanian Lyceum of Sciences and Innovation, Municipality of Korça

Klienti: FONDI SHQIPTAR I ZHVILLIMIT
 Client: ALBANIAN DEVELOPMENT FUND

iRI <small>Local Architecture Office Studio Lukasz Arkitekture Georgiy</small>	N.6844	Firma / Signature: Lexoj dhe aprovoj / I read and approve.
ARCHISPACE <small>Local Architecture Office Studio Lukasz Arkitekture Paw Polow</small>	N.6732/14	Firma / Signature: Lexoj dhe aprovoj / I read and approve.
SPHAERA <small>Local Architecture Office Studio Lukasz Arkitekture Amit Topani</small>	N.4654/14	Firma / Signature: Lexoj dhe aprovoj / I read and approve.
LORENC BEGAJ AVE CONSULTING <small>Consultor/Studio Studio Korombani Ing. Arben Dereshi Ing. Ervil Dusha Ing. Na Hoxha</small>	K.2138/2 N.5628/12	Firma / Signature: Lexoj dhe aprovoj / I read and approve.
BURHAN TURKESHI ERMIR GJOKA <small>Hydro-Mechanical Engineering Insheni Hoxha/Marko dhe IMZ</small>	K.1873/4 M.1174/2	Firma / Signature: Lexoj dhe aprovoj / I read and approve.
BASHKIM SHAHINAJ BESART DALLIU <small>Electrical Engineering Insheni Duka</small>	E.0185/6 E.1412/2	Firma / Signature: Lexoj dhe aprovoj / I read and approve.

ALL DIMENSIONS HAVE TO BE VERIFIED BY THE CONTRACTOR ON THE CONSTRUCTION SITE.
 IMPORTANT: These drawings are property of iRI. Rruga DERSVISH HIMA, nr 8 kat i pare - 1001 TIRANA. Copy, multiplication or distribution in whole or in part of these plans (or any part of it) without written permission of iRI is prohibited.

TE GJITHA DIMENSIONET DUHET TE VERIFIKOHEN NGA KONTRAKTORI NE VEND.
 E RENDËSISHME: këto vizatime janë pronë e iRI, Rruga DERSVISH HIMA, nr 8 kat i pare - 1001 TIRANE. Kopimi, shumëllojimi apo shpërndarja e këtyre vizatimeve (apo pjesëve të tyre) pa lejen me shkrim të iRI është e ndaluar.

Issuer: A	plan number: A.00.4	TITULLI / Title: PLANI I SISTEMIMIT/ LANDSCAPE PLAN
Faza: LN	data: 2026	shkalla e vizatimit: 1:200
		formati: A0

Kati perdhe / Ground floor

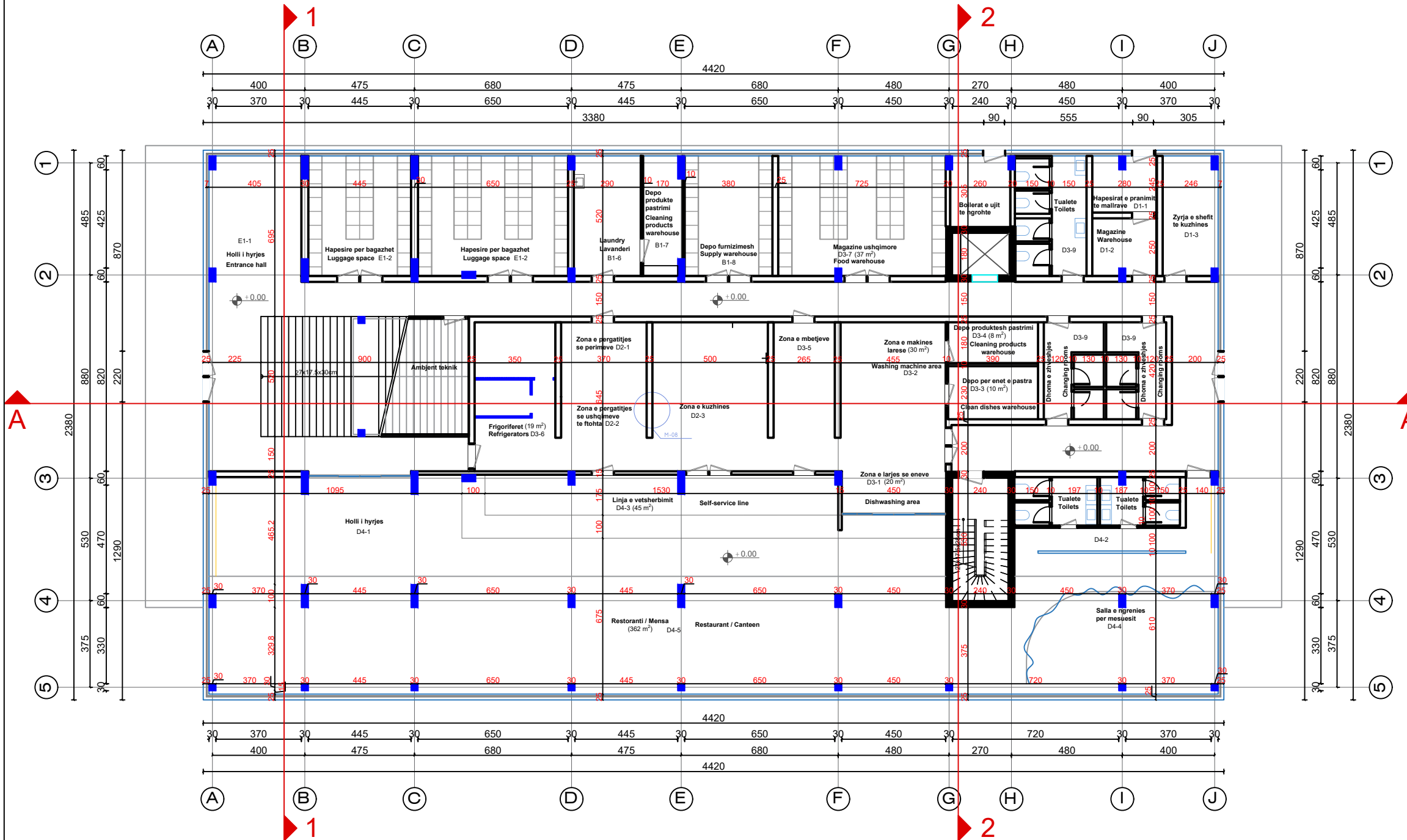

LEGJENDA/ Legenda:

SHENIME/ Notes:

PROJEKTI / Project:
 Ngritja e Infrastrukturës Arsimore të Liceut Franko-Shqiptar të Shkencave dhe Inovacionit, Bashkia Korçë / Establishment of the Educational Infrastructure of the Franco-Albanian Lyceum of Sciences and Innovation, Municipality of Korça

Klienti: FONDI SHQIPTAR I ZHVILLIMIT
 Client: ALBANIAN DEVELOPMENT FUND

IRI Local Architecture Office (LOC) Studio Lokale Arkitekture (VEND) Gent Agall	N.6844	Firma / Signature: Lexoj dhe aprovj / I read and approve.
ARCHISPACE Local Architecture Office (LOC) Studio Lokale Arkitekture (VEND) Rais Petrea	N.6732/14	Firma / Signature: Lexoj dhe aprovj / I read and approve.
SPHAERA Local Architecture Office (LOC) Studio Lokale Arkitekture (VEND) Ajdik Topore	N.4654/14	Firma / Signature: Lexoj dhe aprovj / I read and approve.
LORENC BEGAJ AVE CONSULTING Construction Studio Studio Konstruksioni ing. Arben Dervishaj ing. Ermal Spahiu ing. Ina Hotaj	K.2138/2 N.5628/12	Firma / Signature: Lexoj dhe aprovj / I read and approve.
BURHAN TURKESHI ERMIR GJOKA Hydro-Mechanical Engineering Inzhineri Hidro-Mekanik dhe MNZ	K.1873/4 M.1174/2	Firma / Signature: Lexoj dhe aprovj / I read and approve.
BASHKIM SHAHINAJ BESART DALLIU Electrical Engineering Inzhineri Elektrik	E.0185/6 E.1412/2	Firma / Signature: Lexoj dhe aprovj / I read and approve.

ALL DIMENSIONS HAVE TO BE VERIFIED BY THE CONTRACTOR ON THE CONSTRUCTION SITE
 IMPORTANT: These drawings are property of IRI. Rruga Dervish HIMA, nr 8 kati i pare - 1001 TIRANA. Copy, multiplication or distribution between parties of these plans (or any part of it) without written permission of IRI is prohibited.

TË GJITHA DIMENSIONET DUHET TË VERIFIKOHEN NGA KONTRAKTORI NË VEND
 E RËNDËSISHME: Këto vizatime janë pronë e IRI, Rruga DERVISH HIMA, nr 8 kati i parë - 1001 TIRANË. Kopjimi, shumfishimi apo shpërndarja e këtyre vizatimeve (apo pjesëve të tyre) pa lejen me shkrim të IRI është e ndaluar.

issuer A	plan number: A.00.1	TITULLI / Title: PLANI I KATIT 0 (perdhe) teknik _ Konvikti	
Faza: LN	data: 2026	shkalla e vizatimit: 1:200	formati: A3

Kati perdhe / Ground floor

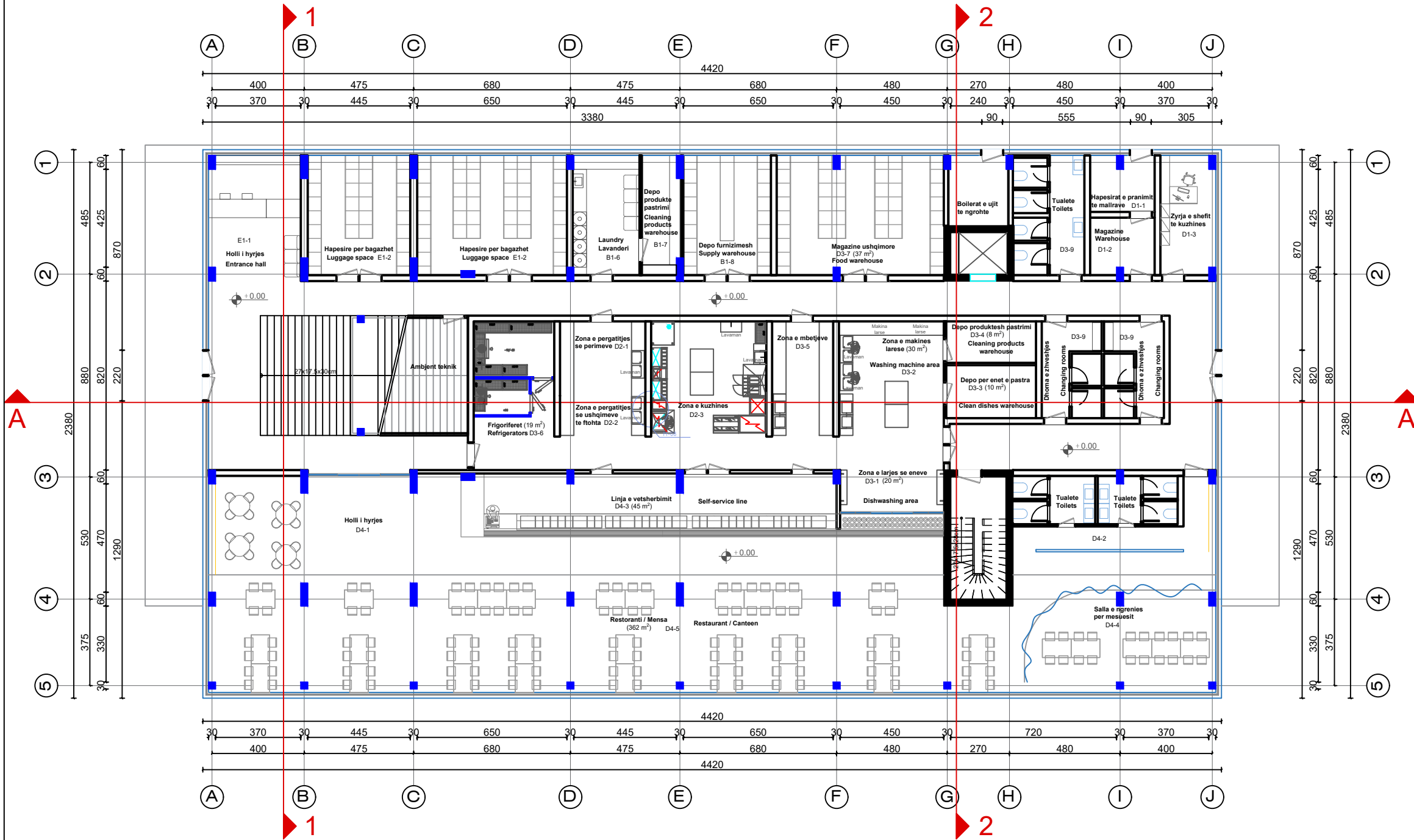

LEGJENDA/ Legenda:

SHENIME/ Notes:

PROJEKTI / Project:
Ngritja e Infrastrukturës Arsimore të Liceut Franko-Shqiptar të Shkencave dhe Inovacionit, Bashkia Korçë / Establishment of the Educational Infrastructure of the Franco-Albanian Lyceum of Sciences and Innovation, Municipality of Korça

Klienti: FONDI SHQIPTAR I ZHVILLIMIT
Client: ALBANIAN DEVELOPMENT FUND

IRI N.6844 Firma / Signature:
Lexoj dhe aprovj / I read and approve.
Local Architecture Office (LOC)
Studio Lokale Arkitekture (VEND)
Gent Agoll

ARCHISPACE N.6732/14 Firma / Signature:
Lexoj dhe aprovj / I read and approve.
Local Architecture Office (LOC)
Studio Lokale Arkitekture (VEND)
Rais Petrela

SPHAERA N.4654/14 Firma / Signature:
Lexoj dhe aprovj / I read and approve.
Local Architecture Office (LOC)
Studio Lokale Arkitekture (VEND)
Aldi Topore

LORENC BEGAJ K.2138/2 Firma / Signature:
AVE CONSULTING N.5628/12 Lexoj dhe aprovj / I read and approve.
Construction Studio
Studio Konstruksioni
ing. Arben Dervishaj
ing. Ermal Spahiu
ing. Ina Hotaj

BURHAN TURKESHI K.1873/4 Firma / Signature:
ERMIR GJOKA M.1174/2 Lexoj dhe aprovj / I read and approve.
Hydro-Mechanical Engineering
Inzhinieri Hidro-Mekanik dhe MNZ

BASHKIM SHAHINAJ E.0185/6 Firma / Signature:
BESART DALLIU E.1412/2 Lexoj dhe aprovj / I read and approve.
Electrical Engineering
Inzhinieri Elektrik

ALL DIMENSIONS HAVE TO BE VERIFIED BY THE CONTRACTOR ON THE CONSTRUCTION SITE
IMPORTANT: These drawings are property of IRI. Rruga Dervish HIMA, nr 8 kati i pare - 1001 TIRANA. Copy, multiplication or distribution between parties of these plans (or any part of it) without written permission of IRI is prohibited.

TË GJITHA DIMENSIONET DUHET TË VERIFIKOHEN NGA KONTRAKTORI NË VEND
E RËNDËSISHME: Këto vizatime janë pronë e IRI. Rruga DERVISH HIMA, nr 8 kati i parë - 1001 TIRANË. Kopjimi, shumfishimi apo shpërndarja e këtyre vizatimeve (apo pjesëve të tyre) pa lejen me shkrim të IRI është e ndaluar.

issuer: **A** plan number: **A.00.1** TITULLI / Title: **PLANI I KATIT 0 (perdhe) mobilim _ Konvikti**

Faza: **LN** data: **2026** shkalla e vizatimit: **1:200** formati: **A3**



Kati +1 / Floor +1

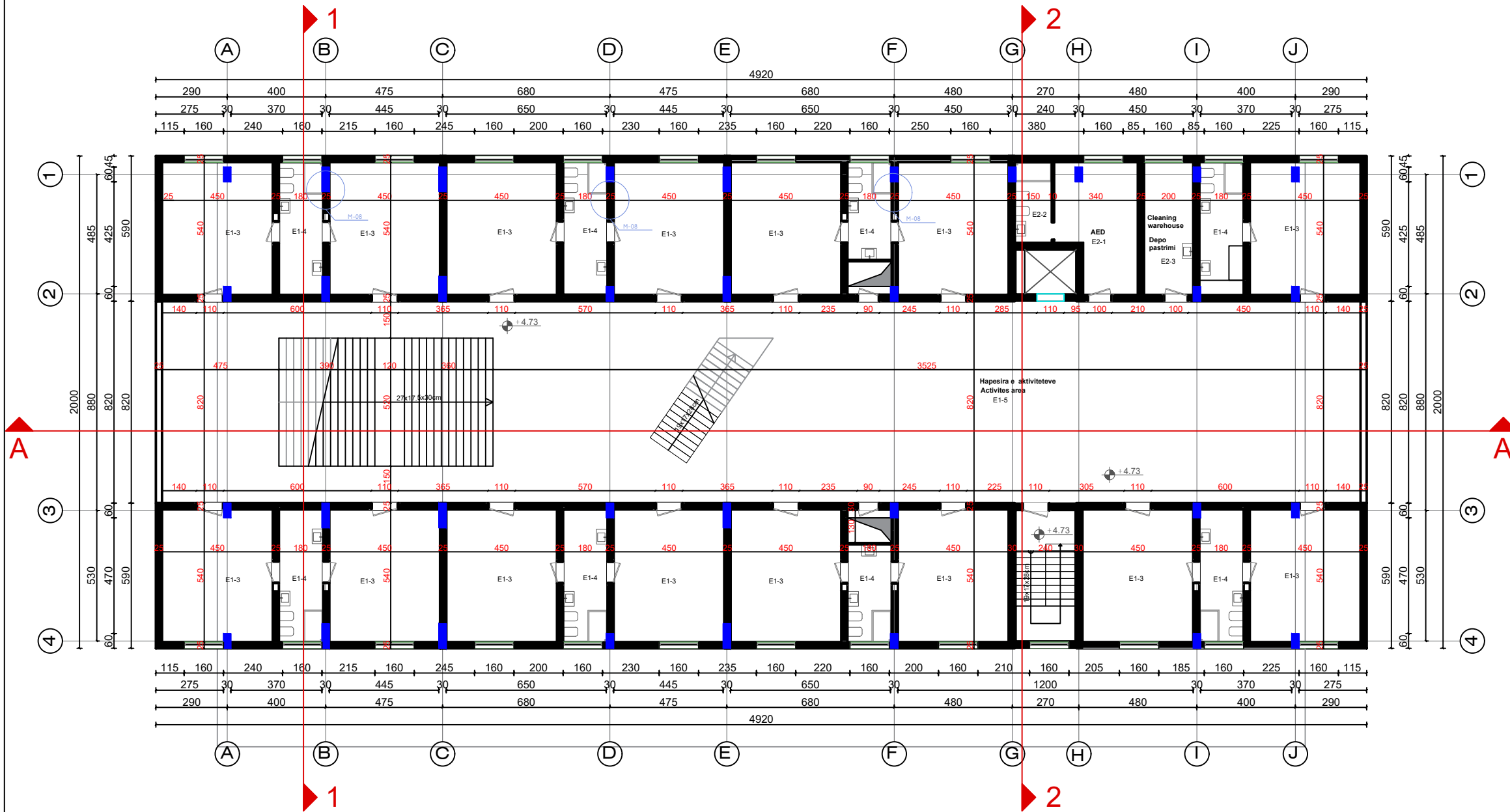

LEGJENDA/ Legenda:

SHENIME/ Notes:

PROJEKTI / Project:
 Ngritja e Infrastrukturës Arsimore të Liceut Franko-Shqiptar të Shkencave dhe Inovacionit, Bashkia Korçë / Establishment of the Educational Infrastructure of the Franco-Albanian Lyceum of Sciences and Innovation, Municipality of Korça

Klienti: FONDI SHQIPTAR I ZHVILLIMIT
 Client: ALBANIAN DEVELOPMENT FUND

iRI Local Architecture Office (LOC) Studio Lokale Arkitekture (VEND) Gent Agall	N.6844	Firma / Signature: Lexoj dhe aprovoj / I read and approve.
ARCHISPACE Local Architecture Office (LOC) Studio Lokale Arkitekture (VEND) Rais Petrea	N.6732/14	Firma / Signature: Lexoj dhe aprovoj / I read and approve.
SPHAERA Local Architecture Office (LOC) Studio Lokale Arkitekture (VEND) Ajdin Topore	N.4654/14	Firma / Signature: Lexoj dhe aprovoj / I read and approve.
LORENC BEGAJ AVE CONSULTING Construction Studio Studio Konstruksioni ing. Arben Dervishi ing. Ermal Spahiu ing. Ina Hotaj	K.2138/2 N.5628/12	Firma / Signature: Lexoj dhe aprovoj / I read and approve.
BURHAN TURKESHI ERMIR GJOKA Hydro-Mechanical Engineering Inzhinieri Hidro-Mekanik dhe MNZ	K.1873/4 M.1174/2	Firma / Signature: Lexoj dhe aprovoj / I read and approve.
BASHKIM SHAHINAJ BESART DALLIU Electrical Engineering Inzhinieri Elektrik	E.0185/6 E.1412/2	Firma / Signature: Lexoj dhe aprovoj / I read and approve.
ALL DIMENSIONS HAVE TO BE VERIFIED BY THE CONTRACTOR ON THE CONSTRUCTION SITE		TË GJITHA DIMENSIONET DUHET TË VERIFIKOHEN NGA KONTRAKTORI NË VEND
IMPORTANT: These drawings are property of iRI. Rruga DERSHVI HIMA, nr 8 kati i pare - 1001 TIRANA. Copy, multiplication or distribution inbetween parties of these plans (or any part of it) without written permission of iRI is prohibited.		E RËNDËSISHME: Këto vizatime janë pronë e iRI. Rruga DERSHVI HIMA, nr 8 kati i parë - 1001 TIRANË. Kopjimi, shumfishimi apo shpërndarja e këtyre vizatimeve (apo pjesëve të tyre) pa lejen me shkrim të iRI është e ndaluar.

issuer A	plan number: A.00.1	TITULLI / Title: PLANI I KATIT +1 teknik _ Konvikt
--------------------	------------------------	--

Faza: LN	data: 2026	shkalla e vizatimit: 1:200	formati: A3	N ↑
-------------	---------------	-------------------------------	----------------	--------

Kati +1 / Floor +1

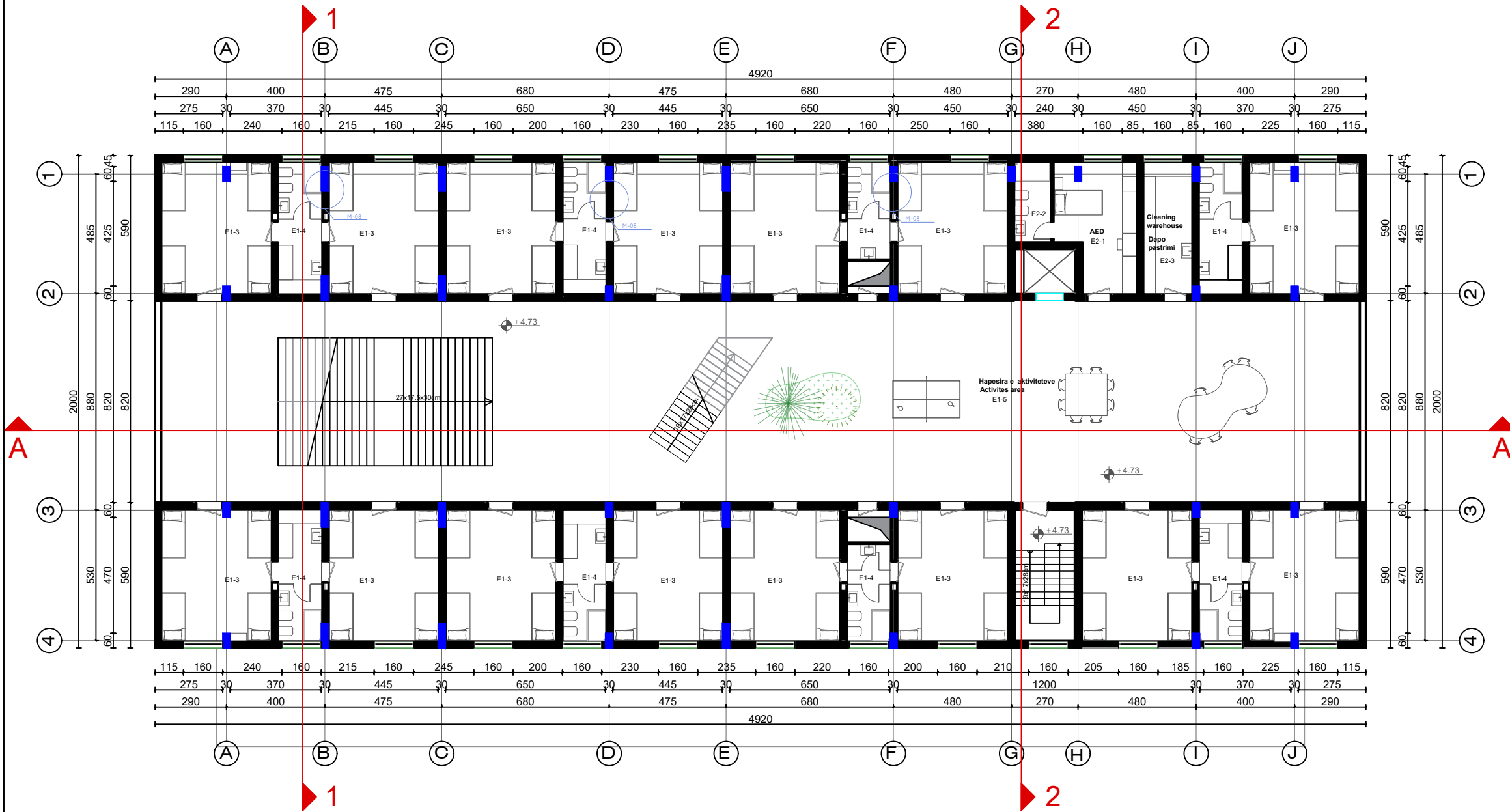

LEGJENDA/ Legenda:

SHËNIME/ Notes:

PROJEKTI / Project:
 Ngritja e Infrastrukturës Arsimore të Liceut Franko-Shqiptar të Shkencave dhe Inovacionit, Bashkia Korçë / Establishment of the Educational Infrastructure of the Franco-Albanian Lyceum of Sciences and Innovation, Municipality of Korça

Klienti: FONDI SHQIPTAR I ZHVILLIMIT
 Client: ALBANIAN DEVELOPMENT FUND

iRI Local Architecture Office (LOC) Studio Lokale Arkitekture (VEND) Gent Agolli	N.6844	Firma / Signature: Lexoj dhe aprovj / I read and approve.
ARCHISPACE Local Architecture Office (LOC) Studio Lokale Arkitekture (VEND) Rais Petrelia	N.6732/14	Firma / Signature: Lexoj dhe aprovj / I read and approve.
SPHAERA Local Architecture Office (LOC) Studio Lokale Arkitekture (VEND) Aldid Topore	N.4654/14	Firma / Signature: Lexoj dhe aprovj / I read and approve.
LORENC BEGAJ AVE CONSULTING Construction Studio Studio Konstruksion ing. Arben Dervishaj ing. Ermal Spahiu ing. Ina Hoxhaj	K.2138/2 N.5628/12	Firma / Signature: Lexoj dhe aprovj / I read and approve.
BURHAN TURKESHI ERMIR GJOKA Hydro-Mechanical Engineering Inzhineri Hidro-Mekanik dhe MNZ	K.1873/4 M.1174/2	Firma / Signature: Lexoj dhe aprovj / I read and approve.
BASHKIM SHAHINAJ BESART DALLIU Electrical Engineering Inzhineri Elektrik	E.0185/6 E.1412/2	Firma / Signature: Lexoj dhe aprovj / I read and approve.

ALL DIMENSIONS HAVE TO BE VERIFIED BY THE CONTRACTOR ON THE CONSTRUCTION SITE
 IMPORTANT: These drawings are property of iRI. Rruga DERSH HIMA, nr 8 kati i pare - 1001 TIRANA. Copy, multiplication or distribution inbetween parties of these plans (or any part of it) without written permission of iRI is prohibited.

TË GJITHA DIMENSIONET DUHET TË VERIFIKOHEN NGA KONTRAKTORI NË VEND
 E RËNDËSISHME: Këto vizatime janë pronë e iRI. Rruga DERSH HIMA, nr 8 kati i parë - 1001 TIRANË. Kopjimi, shumfishimi apo shpërndarja e këtyre vizatimeve (apo pjesëve të tyre) pa lejen me shkrim të iRI është e ndaluar.

issuer A	plan number: A.00.1	TITULLI / Title: PLANI I KATIT +1 mobilim _ Konvikti	
Faza: LN	data: 2026	shkalla e vizatimit: 1:200	formati: A3

Kati +2 / Floor +2

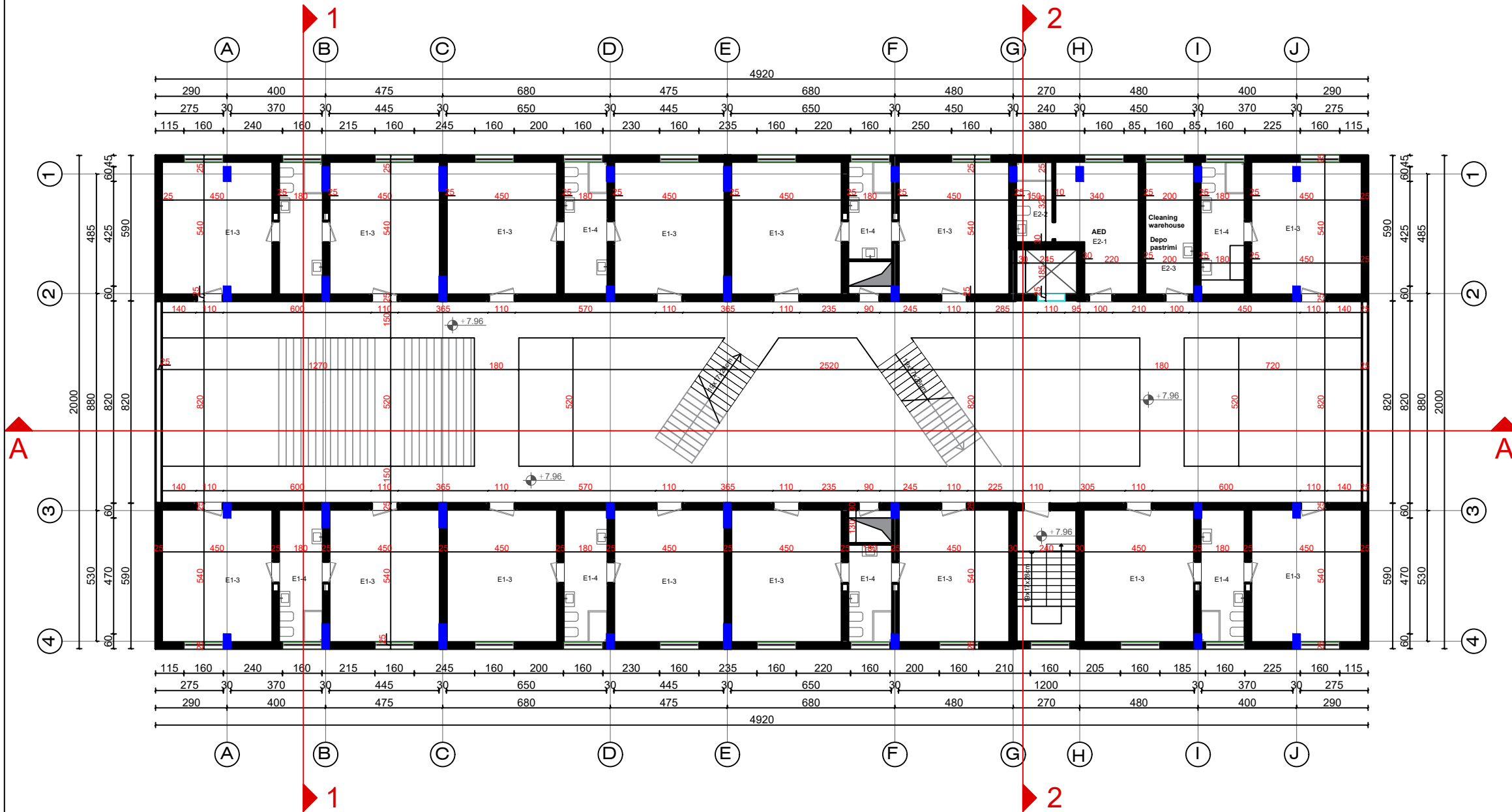

LEGJENDA/ Legenda:

SHENIME/ Notes:

PROJEKTI / Project:
 Ngritja e Infrastrukturës Arsimore të Liceut Franko-Shqiptar të Shkencave dhe Inovacionit, Bashkia Korçë / Establishment of the Educational Infrastructure of the Franco-Albanian Lyceum of Sciences and Innovation, Municipality of Korça

Klienti: FONDI SHQIPTAR I ZHVILLIMIT
 Client: ALBANIAN DEVELOPMENT FUND

IRI N.6844 Firma / Signature:
 Lexoj dhe aprovoj / I read and approve.
Local Architecture Office (LOC)
 Studio Lokale Arkitekture (VEND)
 Gent Agalli

ARCHISPACE N.6732/14 Firma / Signature:
 Lexoj dhe aprovoj / I read and approve.
Local Architecture Office (LOC)
 Studio Lokale Arkitekture (VEND)
 Rais Petrea

SPHAERA N.4654/14 Firma / Signature:
 Lexoj dhe aprovoj / I read and approve.
Local Architecture Office (LOC)
 Studio Lokale Arkitekture (VEND)
 Ajkid Topore

LORENC BEGAJ K.2138/2 Firma / Signature:
AVE CONSULTING N.5628/12 Lexoj dhe aprovoj / I read and approve.
Construction Studio
 Studio Konstruksioni
 Ing. Arben Dervishaj
 Ing. Ermal Spahiu
 Ing. Ina Hotaj

BURHAN TURKESHI K.1873/4 Firma / Signature:
ERMIR GJOKA M.1174/2 Lexoj dhe aprovoj / I read and approve.
Hydro-Mechanical Engineering
 Inzhinieri Hidro-Mekanik dhe MNZ

BASHKIM SHAHINAJ E.0185/6 Firma / Signature:
BESART DALLIU E.1412/2 Lexoj dhe aprovoj / I read and approve.
Electrical Engineering
 Inzhinieri Elektrik

ALL DIMENSIONS HAVE TO BE VERIFIED BY THE CONTRACTOR ON THE CONSTRUCTION SITE
 IMPORTANT: These drawings are property of IRI. Rruga DERSHVI HIMA, nr 8 kati i pare - 1001 TIRANA. Copy, multiplication or distribution inbetween parties of these plans (or any part of it) without written permission of IRI is prohibited.
 TË GJITHA DIMENSIONET DUHET TË VERIFIKOHEN NGA KONTRAKTORI NË VËND
 E RËNDËSISHME: Këto vizatime janë pronë e IRI, Rruga DERSHVI HIMA, nr 8 kati i parë - 1001 TIRANË. Kopjimi, shumfishimi apo shpërndarja e këtyre vizatimeve (apo pjesëve të tyre) pa lejen me shkrim të IRI është e ndaluar.

issuer A	plan number: A.00.1	TITULLI / Title: PLANI I KATIT +2 teknik _ Konvikt	
Faza: LN	data: 2026	shkalla e vizatimit: 1:200	formati: A3



Kati +2 / Floor +2

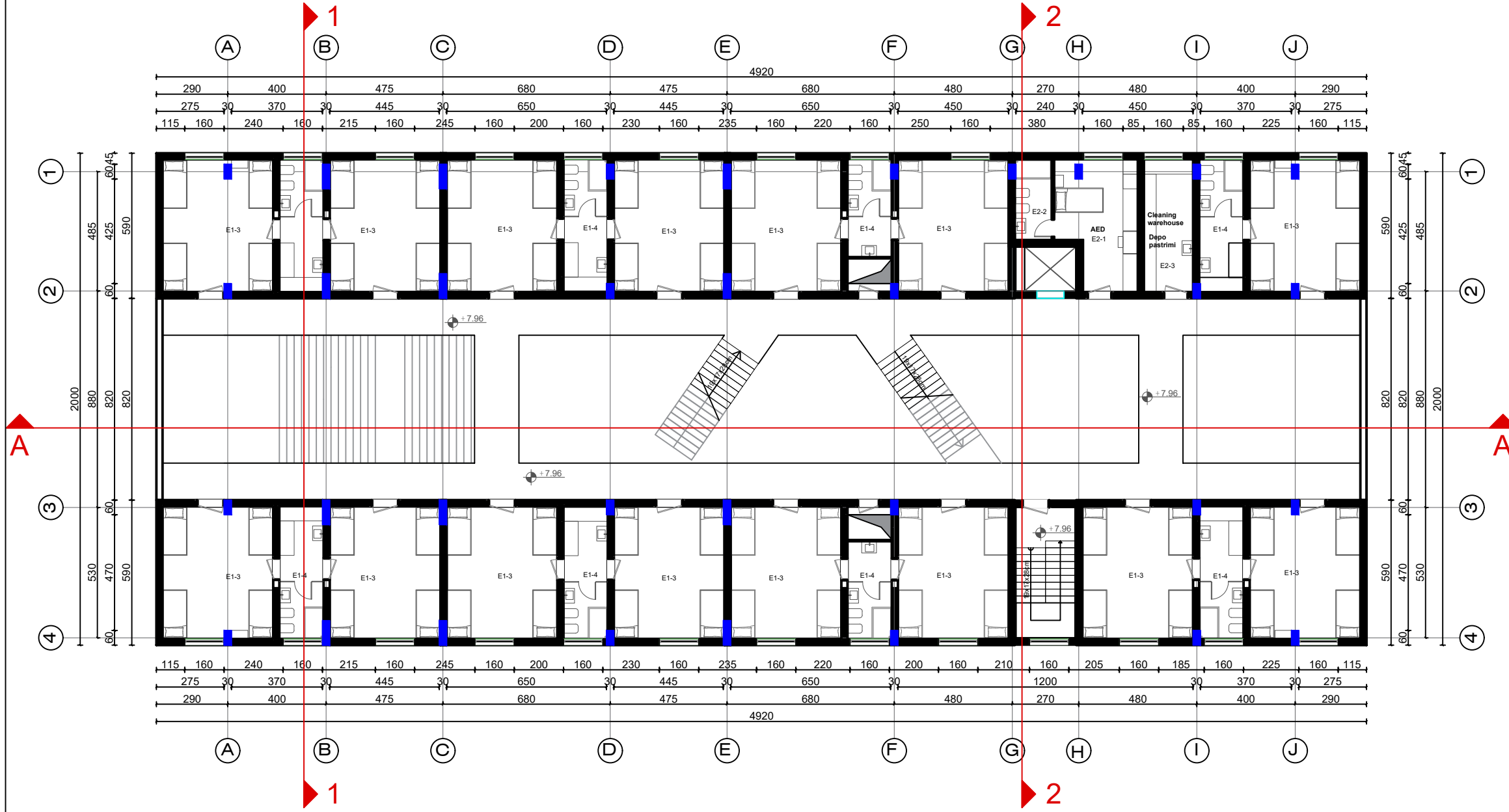

LEGJENDA/ Legenda:

SHËNIME/ Notes:

PROJEKTI / Project:
 Ngritja e Infrastrukturës Arsimore të Liceut Franko-Shqiptar të Shkencave dhe Inovacionit, Bashkia Korçë / Establishment of the Educational Infrastructure of the Franco-Albanian Lyceum of Sciences and Innovation, Municipality of Korçë

Klienti: FONDI SHQIPTAR I ZHVILLIMIT
 Client: ALBANIAN DEVELOPMENT FUND

IRI N.6844 Firma / Signature:
 Lexoj dhe aprovoj / I read and approve.

Local Architecture Office (LOC)
 Studio Lokale Arkitekture (VEND)
 Gent Agolli

ARCHISPACE N.6732/14 Firma / Signature:
 Lexoj dhe aprovoj / I read and approve.

Local Architecture Office (LOC)
 Studio Lokale Arkitekture (VEND)
 Rais Petrela

SPHAERA N.4654/14 Firma / Signature:
 Lexoj dhe aprovoj / I read and approve.

Local Architecture Office (LOC)
 Studio Lokale Arkitekture (VEND)
 Ajlind Topore

LORENC BEGAJ K.2138/2 Firma / Signature:
AVE CONSULTING N.5628/12 Lexoj dhe aprovoj / I read and approve.

Construction Studio
 Studio Konstruksioni
 Ing. Arben Dervishi
 Ing. Ermal Spahiu
 Ing. Ina Hoxhaj

BURHAN TURKESHI K.1873/4 Firma / Signature:
ERMIR GJOKA M.1174/2 Lexoj dhe aprovoj / I read and approve.

Hydro-Mechanical Engineering
 Inzhinieri Hidro-Mekanik dhe MNZ

BASHKIM SHAHINAJ E.0185/6 Firma / Signature:
BESART DALLIU E.1412/2 Lexoj dhe aprovoj / I read and approve.

Electrical Engineering
 Inzhinieri Elektrik

ALL DIMENSIONS HAVE TO BE VERIFIED BY THE CONTRACTOR ON THE CONSTRUCTION SITE
 IMPORTANT: These drawings are property of IRI. Rruga Dervishi HIMA, nr 8 kati i pare – 1001 TIRANA. Copy, multiplication or distribution inbetween parties of these plans (or any part of it) without written permission of IRI is prohibited.

TË GJITHA DIMENSIONET DUJET TË VERIFIKOHEN NGA KONTRAKTORI NË VEND
 E RËNDËSISHME: Këto vizatime janë pronë e IRI. Rruga DERVISHI HIMA, nr 8 kati i pare – 1001 TIRANË. Kopjimi, shumfishimi apo shpërndarja e këtyre vizatimeve (apo pjesëve të tyre) pa lejen me shkrim të IRI është e ndaluar.

issuer A	plan number: A.00.1	TITULLI / Title: PLANI I KATIT +2 mobilim _ Konvikti
--------------------	------------------------	--

Faza: LN	data: 2026	shkalla e vizatimit: 1:200	formati: A3	N ↑
-------------	---------------	-------------------------------	----------------	--------

Kati +3 / Floor +3

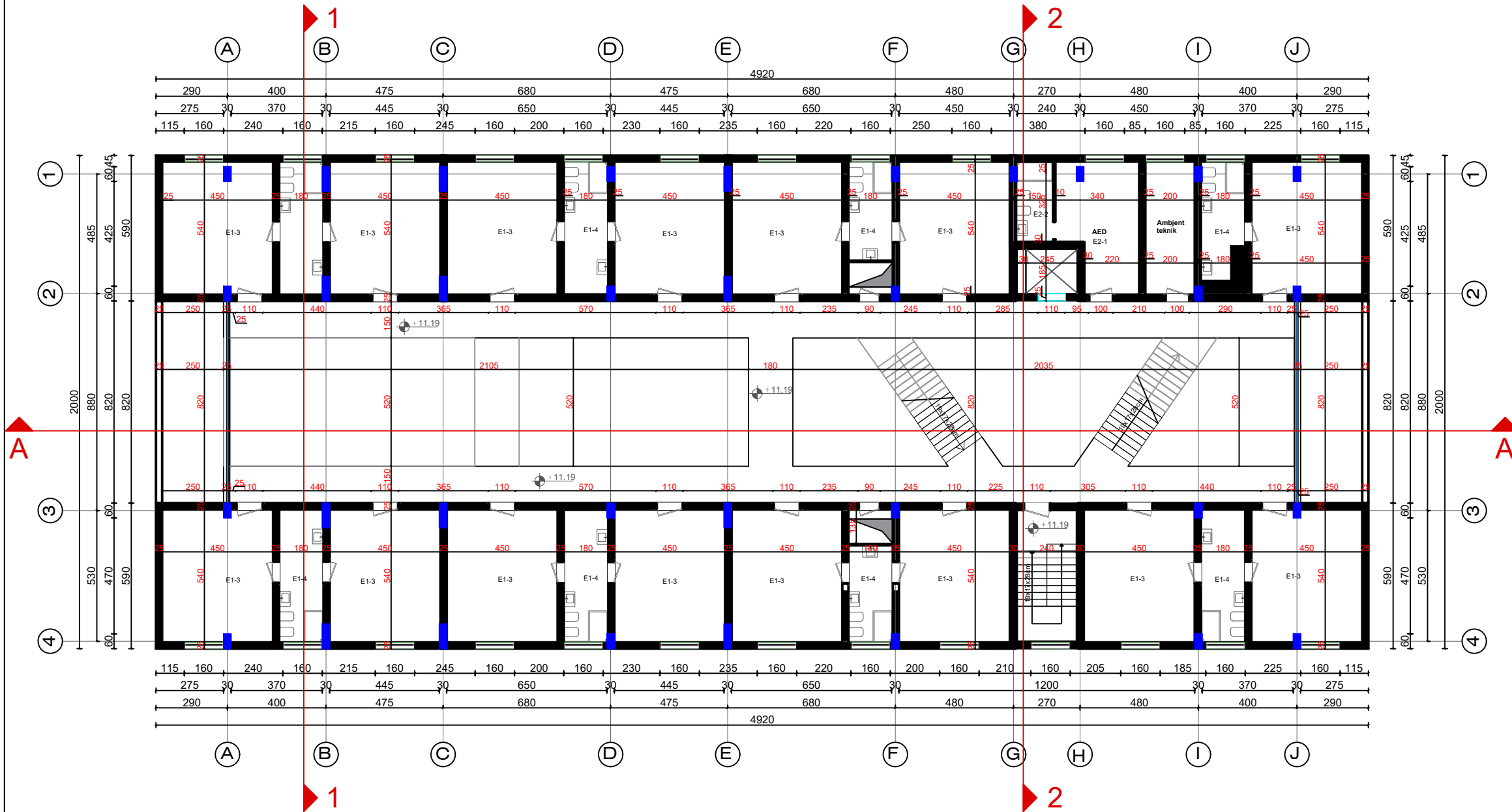

LEGJENDA/ Legenda:

SHENIME/ Notes:

PROJEKTI / Project:
Ngritja e Infrastrukturës Arsimore të Liceut Franko-Shqiptar të Shkencave dhe Inovacionit, Bashkia Korçë / Establishment of the Educational Infrastructure of the Franco-Albanian Lyceum of Sciences and Innovation, Municipality of Korça

Klienti: FONDI SHQIPTAR I ZHVILLIMIT
Client: ALBANIAN DEVELOPMENT FUND

IRI N.6844 Firma / Signature:
Lexoj dhe aprovoj / I read and approve.
Local Architecture Office (L.O.C)
Studio Lokale Arkitekture (VEND)
Gent Agoll

ARCHISPACE N.6732/14 Firma / Signature:
Lexoj dhe aprovoj / I read and approve.
Local Architecture Office (L.O.C)
Studio Lokale Arkitekture (VEND)
Rais Petrea

SPHAERA N.4654/14 Firma / Signature:
Lexoj dhe aprovoj / I read and approve.
Local Architecture Office (L.O.C)
Studio Lokale Arkitekture (VEND)
Ajdin Topore

LORENC BEGAJ K.2138/2 Firma / Signature:
AVE CONSULTING N.5628/12 Lexoj dhe aprovoj / I read and approve.
Construction Studio
Studio Konstruksioni
ing. Arben Dervishaj
ing. Ermal Spahiu
ing. Ina Hotaj

BURHAN TURKESHI K.1873/4 Firma / Signature:
ERMIR GJOKA M.1174/2 Lexoj dhe aprovoj / I read and approve.
Hydro-Mechanical Engineering
Inzhinieri Hidro-Mekanik dhe MNZ

BASHKIM SHAHINAJ E.0185/6 Firma / Signature:
BESART DALLIU E.1412/2 Lexoj dhe aprovoj / I read and approve.
Electrical Engineering
Inzhinieri Elektrik

ALL DIMENSIONS HAVE TO BE VERIFIED BY THE CONTRACTOR ON THE CONSTRUCTION SITE
IMPORTANT: These drawings are property of IRI. Rruga DERSH HIMA, nr 8 kati i pare - 1001 TIRANA. Copy, multiplication or distribution inbetween parties of these plans (or any part of it) without written permission of IRI is prohibited.

TË GJITHA DIMENSIONET DUHET TË VERIFIKOHEN NGA KONTRAKTORI NË VEND
E RËNDËSISHME: Këto vizatime janë pronë e IRI, Rruga DERSH HIMA, nr 8 kati i parë - 1001 TIRANË. Kopjimi, shumfishimi apo shpërndarja e këtyre vizatimeve (apo pjesëve të tyre) pa lejen me shkrim të IRI është e ndaluar.

issuer A	plan number: A.00.1	TITULLI / Title: PLANI I KATIT +3 teknik _ Konvikt	
Faza: LN	data: 2026	shkalla e vizatimit: 1:200	formati: A3



Kati +3 / Floor +3

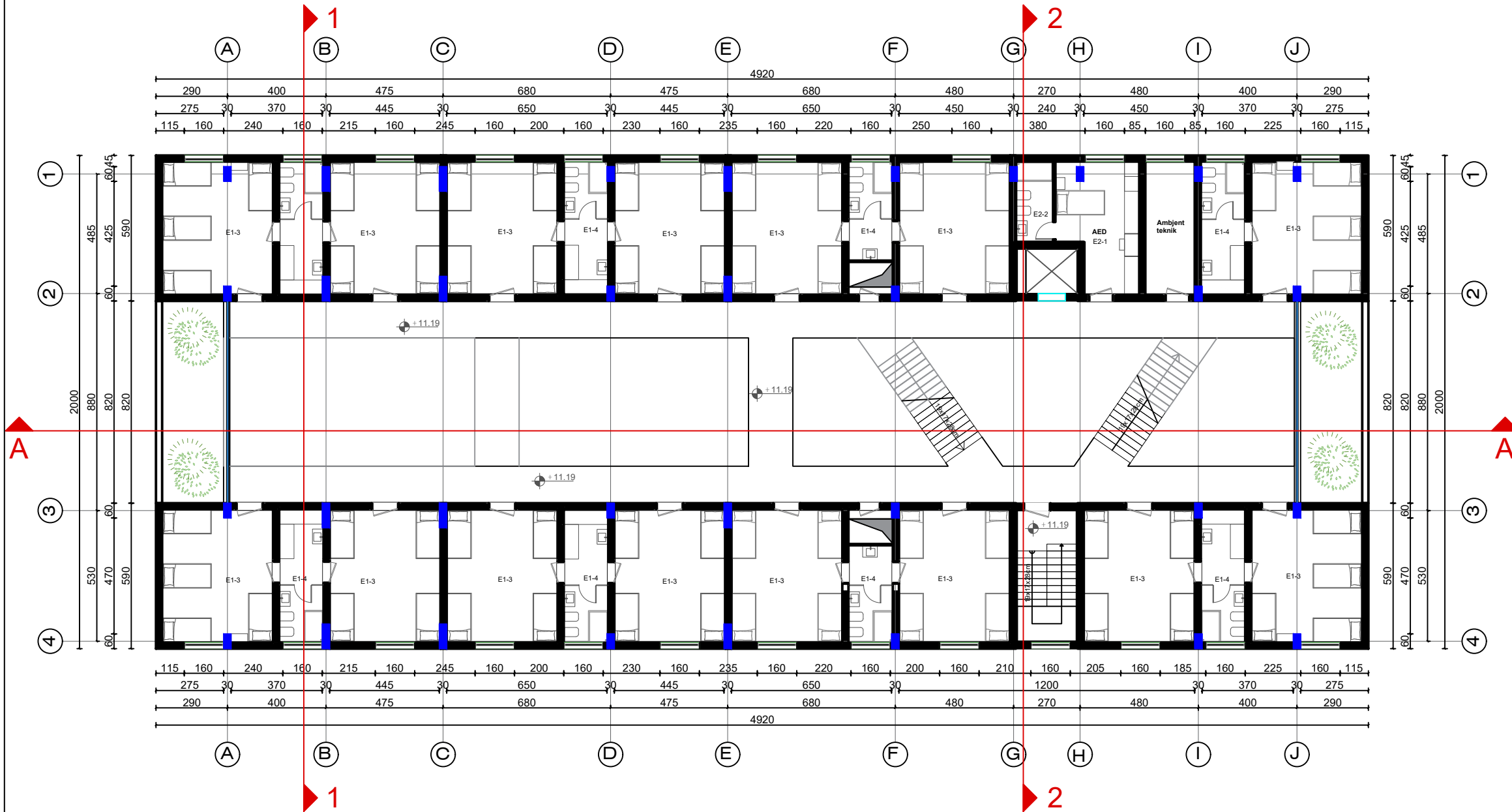

LEGJENDA/ Legenda:

SHENIME/ Notes:

PROJEKTI / Project:
 Ngritja e Infrastrukturës Arsimore të Liceut Franko-Shqiptar të Shkencave dhe Inovacionit, Bashkia Korçë / Establishment of the Educational Infrastructure of the Franco-Albanian Lyceum of Sciences and Innovation, Municipality of Korça

Klienti: FONDI SHQIPTAR I ZHVILLIMIT
 Client: ALBANIAN DEVELOPMENT FUND

IRI Local Architecture Office (LOC) Studio Lokale Arkitekture (VEND) Gent Agoll	N.6844	Firma / Signature: Lexoj dhe aprovoj / I read and approve.
ARCHISPACE Local Architecture Office (LOC) Studio Lokale Arkitekture (VEND) Rais Petrela	N.6732/14	Firma / Signature: Lexoj dhe aprovoj / I read and approve.
SPHAERA Local Architecture Office (LOC) Studio Lokale Arkitekture (VEND) Ajdin Topore	N.4654/14	Firma / Signature: Lexoj dhe aprovoj / I read and approve.
LORENC BEGAJ AVE CONSULTING Construction Studio Studio Konstruksioni ing. Arben Dervishi ing. Ermal Spahiu ing. Ina Hotaj	K.2138/2 N.5628/12	Firma / Signature: Lexoj dhe aprovoj / I read and approve.
BURHAN TURKESHI ERMIR GJOKA Hydro-Mechanical Engineering Inzhinieri Hidro-Mekanik dhe MNZ	K.1873/4 M.1174/2	Firma / Signature: Lexoj dhe aprovoj / I read and approve.
BASHKIM SHAHINAJ BESART DALLIU Electrical Engineering Inzhinieri Elektrik	E.0185/6 E.1412/2	Firma / Signature: Lexoj dhe aprovoj / I read and approve.

ALL DIMENSIONS HAVE TO BE VERIFIED BY THE CONTRACTOR ON THE CONSTRUCTION SITE
 IMPORTANT: These drawings are property of IRI. Rruga Dervishi HIMA, nr 8 kati i pare - 1001 TIRANA. Copy, multiplication or distribution inbetween parties of these plans (or any part of it) without written permission of IRI is prohibited.

TË GJITHA DIMENSIONET DUHET TË VERIFIKOHEN NGA KONTRAKTORI NË VËND
 E RËNDËSISHME: Këto vizatime janë pronë e IRI, Rruga DERVISHI HIMA, nr 8 kati i parë - 1001 TIRANË. Kopjimi, shumfishimi apo shpërndarja e këtyre vizatimeve (apo pjesëve të tyre) pa lejen me shkrim të IRI është e ndaluar.

issuer A	plan number: A.00.1	TITULLI / Title: PLANI I KATIT +3 mobilim _ Konvikti	
Faza: LN	data: 2026	shkalla e vizatimit: 1:200	formati: A3

Kati +4 / Floor +4

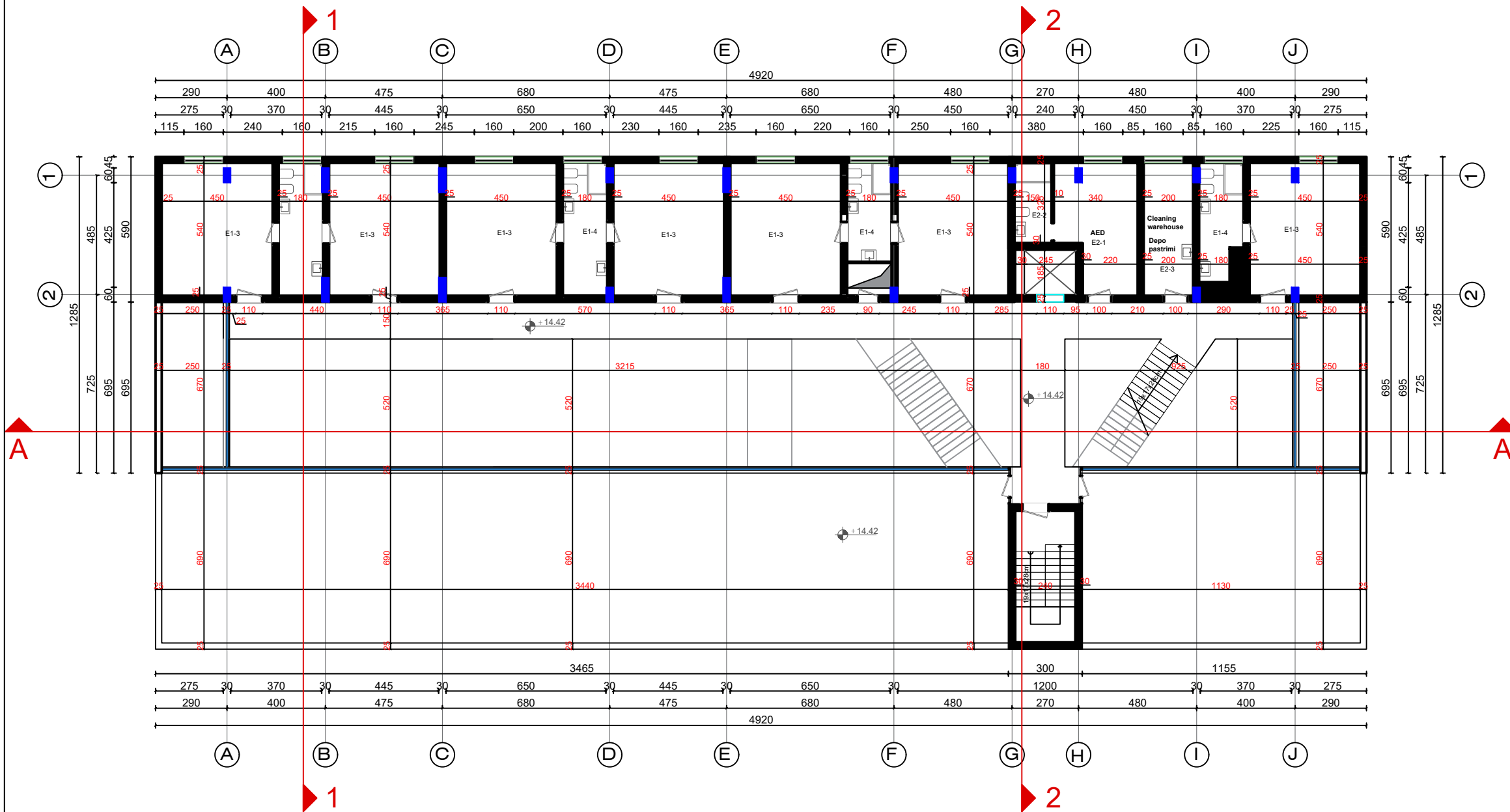

LEGJENDA/ Legenda:

SHENIME/ Notes:

PROJEKTI / Project:
Ngritja e Infrastrukturës Arsimore të Liceut Franko-Shqiptar të Shkencave dhe Inovacionit, Bashkia Korçë / Establishment of the Educational Infrastructure of the Franco-Albanian Lyceum of Sciences and Innovation, Municipality of Korça

Klienti: FONDI SHQIPTAR I ZHVILLIMIT
Client: ALBANIAN DEVELOPMENT FUND

IRI N.6844 Firma / Signature:
Lexoj dhe aprovoj / I read and approve.
Local Architecture Office (LOC)
Studio Lokale Arkitekture (VEND)
Gent Agalli

ARCHISPACE N.6732/14 Firma / Signature:
Lexoj dhe aprovoj / I read and approve.
Local Architecture Office (LOC)
Studio Lokale Arkitekture (VEND)
Rais Petrela

SPHAERA N.4654/14 Firma / Signature:
Lexoj dhe aprovoj / I read and approve.
Local Architecture Office (LOC)
Studio Lokale Arkitekture (VEND)
Ajdik Topore

LORENC BEGAJ K.2138/2 Firma / Signature:
AVE CONSULTING N.5628/12 Lexoj dhe aprovoj / I read and approve.
Construction Studio
Studio Konstruksioni
ing. Arben Dervishaj
ing. Ermal Spahiu
ing. Ina Hotaj

BURHAN TURKESHI K.1873/4 Firma / Signature:
ERMIR GJOKA M.1174/2 Lexoj dhe aprovoj / I read and approve.
Hydro-Mechanical Engineering
Inzhinieri Hidro-Mekanik dhe MNZ

BASHKIM SHAHINAJ E.0185/6 Firma / Signature:
BESART DALLIU E.1412/2 Lexoj dhe aprovoj / I read and approve.
Electrical Engineering
Inzhinieri Elektrik

ALL DIMENSIONS HAVE TO BE VERIFIED BY THE CONTRACTOR ON THE CONSTRUCTION SITE
IMPORTANT: These drawings are property of IRI. Rruga DERSH HIMA, nr 8 kati i pare - 1001 TIRANA. Copy, multiplication or distribution inbetween parties of these plans (or any part of it) without written permission of IRI is prohibited.

TË GJITHA DIMENSIONET DUHET TË VERIFIKOHEN NGA KONTRAKTORI NË VEND
E RËNDËSISHME: Këto vizatime janë pronë e IRI, Rruga DERSH HIMA, nr 8 kati i parë - 1001 TIRANË. Kopjimi, shumfishimi apo shpërndarja e këtyre vizatimeve (apo pjesëve të tyre) pa lejen me shkrim të IRI është e ndaluar.

issuer A	plan number: A.00.1	TITULLI / Title: PLANI I KATIT +4 teknik _ Konvikti	
Faza: LN	data: 2026	shkalla e vizatimit: 1:200	formati: A3



Kati +4 / Floor +4

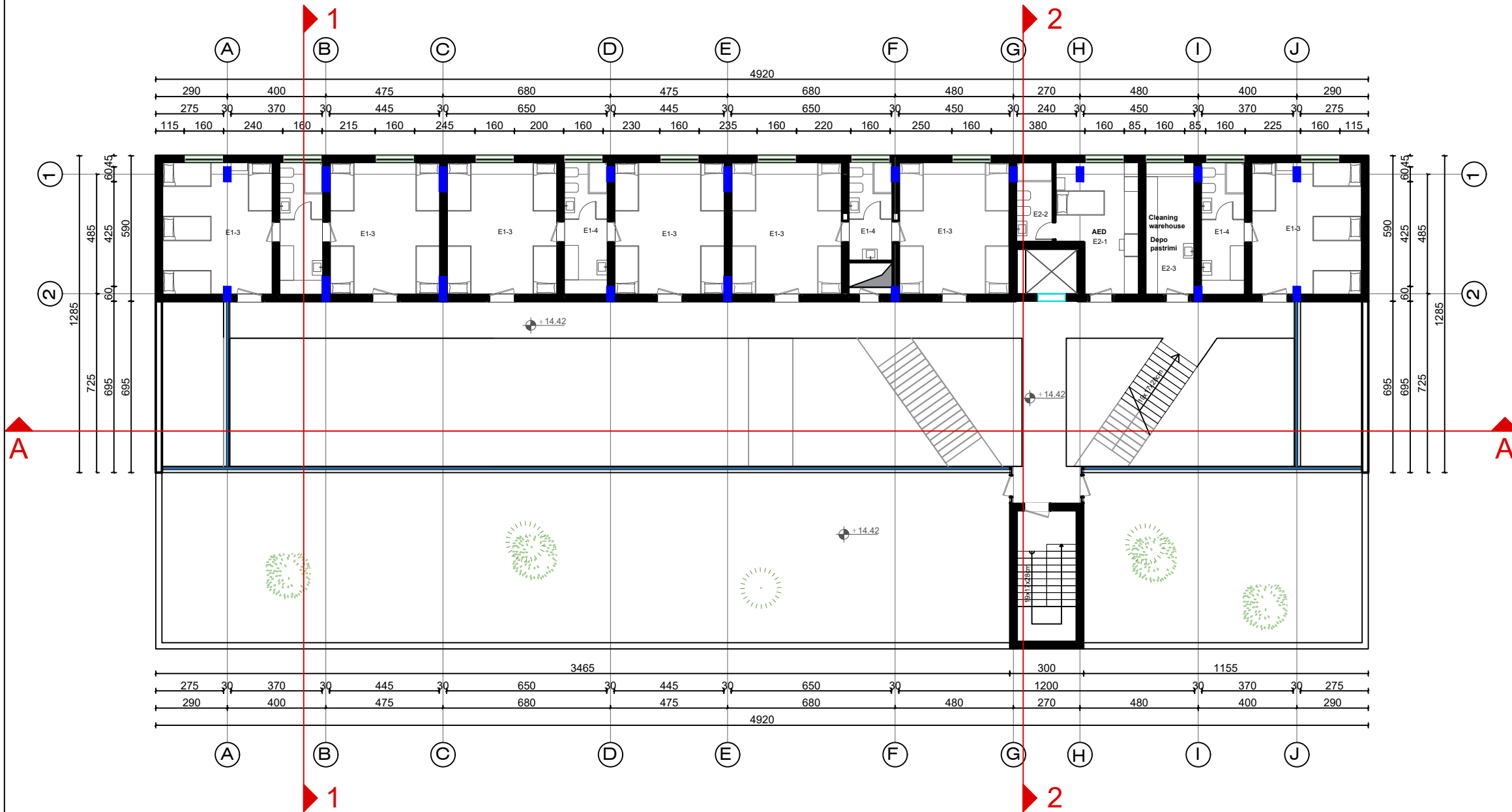

LEGJENDA/ Legenda:

SHENIME/ Notes:

PROJEKTI / Project:
 Ngritja e Infrastrukturës Arsimore të Liceut Franko-Shqiptar të Shkencave dhe Inovacionit, Bashkia Korçë / Establishment of the Educational Infrastructure of the Franco-Albanian Lyceum of Sciences and Innovation, Municipality of Korça

Klienti: FONDI SHQIPTAR I ZHVILLIMIT
 Client: ALBANIAN DEVELOPMENT FUND

IRI N.6844 Firma / Signature:
 Lexoj dhe aprovoj / I read and approve.
 Local Architecture Office (LOC)
 Studio Lokale Arkitekture (VEND)
 Gent Agoll

ARCHISPACE N.6732/14 Firma / Signature:
 Lexoj dhe aprovoj / I read and approve.
 Local Architecture Office (LOC)
 Studio Lokale Arkitekture (VEND)
 Rais Petrela

SPHAERA N.4654/14 Firma / Signature:
 Lexoj dhe aprovoj / I read and approve.
 Local Architecture Office (LOC)
 Studio Lokale Arkitekture (VEND)
 Ajkid Topore

LORENC BEGAJ K.2138/2 Firma / Signature:
AVE CONSULTING N.5628/12 Lexoj dhe aprovoj / I read and approve.
 Construction Studio
 Studio Konstruksioni
 Ing. Arben Dervishaj
 Ing. Ermal Spahiu
 Ing. Ina Hotaj

BURHAN TURKESHI K.1873/4 Firma / Signature:
ERMIR GJOKA M.1174/2 Lexoj dhe aprovoj / I read and approve.
 Hydro-Mechanical Engineering
 Inzhinieri Hidro-Mekanik dhe MNZ

BASHKIM SHAHINAJ E.0185/6 Firma / Signature:
BESART DALLIU E.1412/2 Lexoj dhe aprovoj / I read and approve.
 Electrical Engineering
 Inzhinieri Elektrik

ALL DIMENSIONS HAVE TO BE VERIFIED BY THE CONTRACTOR ON THE CONSTRUCTION SITE
 IMPORTANT: These drawings are property of IRI. Rruga DERSHVI HIMA, nr 8 kati i pare - 1001 TIRANA. Copy, multiplication or distribution inbetween parties of these plans (or any part of it) without written permission of IRI is prohibited.

TË GJITHA DIMENSIONET DUHET TË VERIFIKOHEN NGA KONTRAKTORI NË VËND
 E RËNDËSISHME: Këto vizatime janë pronë e IRI, Rruga DERSHVI HIMA, nr 8 kati i parë - 1001 TIRANË. Kopjimi, shumfishimi apo shpërndarja e këtyre vizatimeve (apo pjesëve të tyre) pa lejen me shkrim të IRI është e ndaluar.

issuer A	plan number: A.00.1	TITULLI / Title: PLANI I KATIT +4 mobilim _ Konvikti	
Faza: LN	data: 2026	shkalla e vizatimit: 1:200	formati: A3





LEGJENDA/ Legenda:

SHËNIME/ Notes:

PROJEKTI / Project:
Ngritja e Infrastrukturës Arsimore të Liceut Franko-Shqiptar të Shkencave dhe Inovacionit, Bashkia Korçë / Establishment of the Educational Infrastructure of the Franco-Albanian Lyceum of Sciences and Innovation, Municipality of Korça

Klienti: FONDI SHQIPTAR I ZHVILLIMIT
Client: ALBANIAN DEVELOPMENT FUND

IRI Local Architecture Office (LOC) Studio Lokale Arkitekture (VEND) Gent Agall	N.6844	Firma / Signature: Lexoj dhe aprovj / I read and approve.
ARCHISPACE Local Architecture Office (LOC) Studio Lokale Arkitekture (VEND) Rais Petra	N.6732/14	Firma / Signature: Lexoj dhe aprovj / I read and approve.
SPHAERA Local Architecture Office (LOC) Studio Lokale Arkitekture (VEND) Aldi Topore	N.4654/14	Firma / Signature: Lexoj dhe aprovj / I read and approve.
LORENC BEGAJ AVE CONSULTING Construction Studio Studio Konstruksioni ing. Arben Demishaj ing. Ermal Spahiu ing. Ina Hoxhaj	K.2138/2 N.5628/12	Firma / Signature: Lexoj dhe aprovj / I read and approve.
BURHAN TURKESHI ERMIR GJOKA Hydro-Mechanical Engineering Inzhinieri Hidro-Mekanik dhe MNZ	K.1873/4 M.1174/2	Firma / Signature: Lexoj dhe aprovj / I read and approve.
BASHKIM SHAHINAJ BESART DALLIU Electrical Engineering Inzhinieri Elektrik	E.0185/6 E.1412/2	Firma / Signature: Lexoj dhe aprovj / I read and approve.

ALL DIMENSIONS HAVE TO BE VERIFIED BY THE CONTRACTOR ON THE CONSTRUCTION SITE
TË GJITHA DIMENSIONET DUHET TË VERIFIKOHEN NGA KONTRAKTORI NË VEND
IMPORTANT: These drawings are property of IRI. Rruga DERSHVI HIMA, nr 8 kati i parë - 1001 TIRANA. Copy, multiplication or distribution between parties of these plans (or any part of it) without written permission of IRI is prohibited.
E RËNDËSISHME: Këto vizatime janë pronë e IRI, Rruga DERSHVI HIMA, nr 8 kati i parë - 1001 TIRANË. Kopjimi, shumfishimi apo shpërndarja e këtyre vizatimeve (apo pjesëve të tyre) pa lejen me shkrim të IRI është e ndaluar.

issuer A	plan number: A.00.1	TITULLI / Title: PRERJE 1-1 _ Konvikti/ SECTION 1-1_Dormitory
Faza: LN	data: 2026	shkalla e vizatimit: 1:150
		formati: A3



LEGJENDA/ Legend:

SHENIME/ Notes:

PROJEKTI / Project:
 Ngritja e Infrastrukturës Arsimore të Liceut Franko-Shqiptar të Shkencave dhe Inovacionit, Bashkia Korçë / Establishment of the Educational Infrastructure of the Franco-Albanian Lyceum of Sciences and Innovation, Municipality of Korça

Klienti: FONDI SHQIPTAR I ZHVILLIMIT
 Client: ALBANIAN DEVELOPMENT FUND

IRI N.6844 Firma / Signature:
 Lexoj dhe aprovoj / I read and approve.
 Local Architecture Office (LOC)
 Studio Lokale Arkitekture (VEND)
 Gent Agall

ARCHISPACE N.6732/14 Firma / Signature:
 Lexoj dhe aprovoj / I read and approve.
 Local Architecture Office (LOC)
 Studio Lokale Arkitekture (VEND)
 Rais Petrela

SPHAERA N.4654/14 Firma / Signature:
 Lexoj dhe aprovoj / I read and approve.
 Local Architecture Office (LOC)
 Studio Lokale Arkitekture (VEND)
 Ajkë Topore

LORENC BEGAJ K.2138/2 Firma / Signature:
AVE CONSULTING N.5628/12 Lexoj dhe aprovoj / I read and approve.
 Construction Studio
 Studio Konstruksioni
 Ing. Arben Demushaj
 Ing. Ermal Spahiu
 Ing. Ina Hotaj

BURHAN TURKESHI K.1873/4 Firma / Signature:
ERMIR GJOKA M.1174/2 Lexoj dhe aprovoj / I read and approve.
 Hydro-Mechanical Engineering
 Inzhineri Hidro-Mekanik dhe MNZ

BASHKIM SHAHINAJ E.0185/6 Firma / Signature:
BESART DALLIU E.1412/2 Lexoj dhe aprovoj / I read and approve.
 Electrical Engineering
 Inzhineri Elektrik

ALL DIMENSIONS HAVE TO BE VERIFIED BY THE CONTRACTOR ON THE CONSTRUCTION SITE
 TË GJITHA DIMENSIONET DUHET TË VERIFIKOHEN NGA KONTRAKTORI NË VEND
 IMPORTANT: These drawings are property of IRI. Rruga DERVISH HIMA, nr 8 kati i parë - 1001 TIRANË. Copy, multiplication or distribution inbetween parties of these plans (or any part of it) without written permission of IRI is prohibited.
 E RËNDËSISHME: Këto vizatime janë pronë e IRI. Rruga DERVISH HIMA, nr 8 kati i parë - 1001 TIRANË. Kopjimi, shumfishimi apo shpërndarja e këtyre vizatimeve (apo pjesëve të tyre) pa lejen me shkrim të IRI është e ndaluar.

issuer A	plan number: A.00.1	TITULLI / Title: PRERJE 2-2 _ Konvikti/ SECTION 2-2_Dormitory
--------------------	------------------------	---

Faza: LN	data: 2026	shkalla e vizatimit: 1:150	formati: A3
-------------	---------------	-------------------------------	----------------

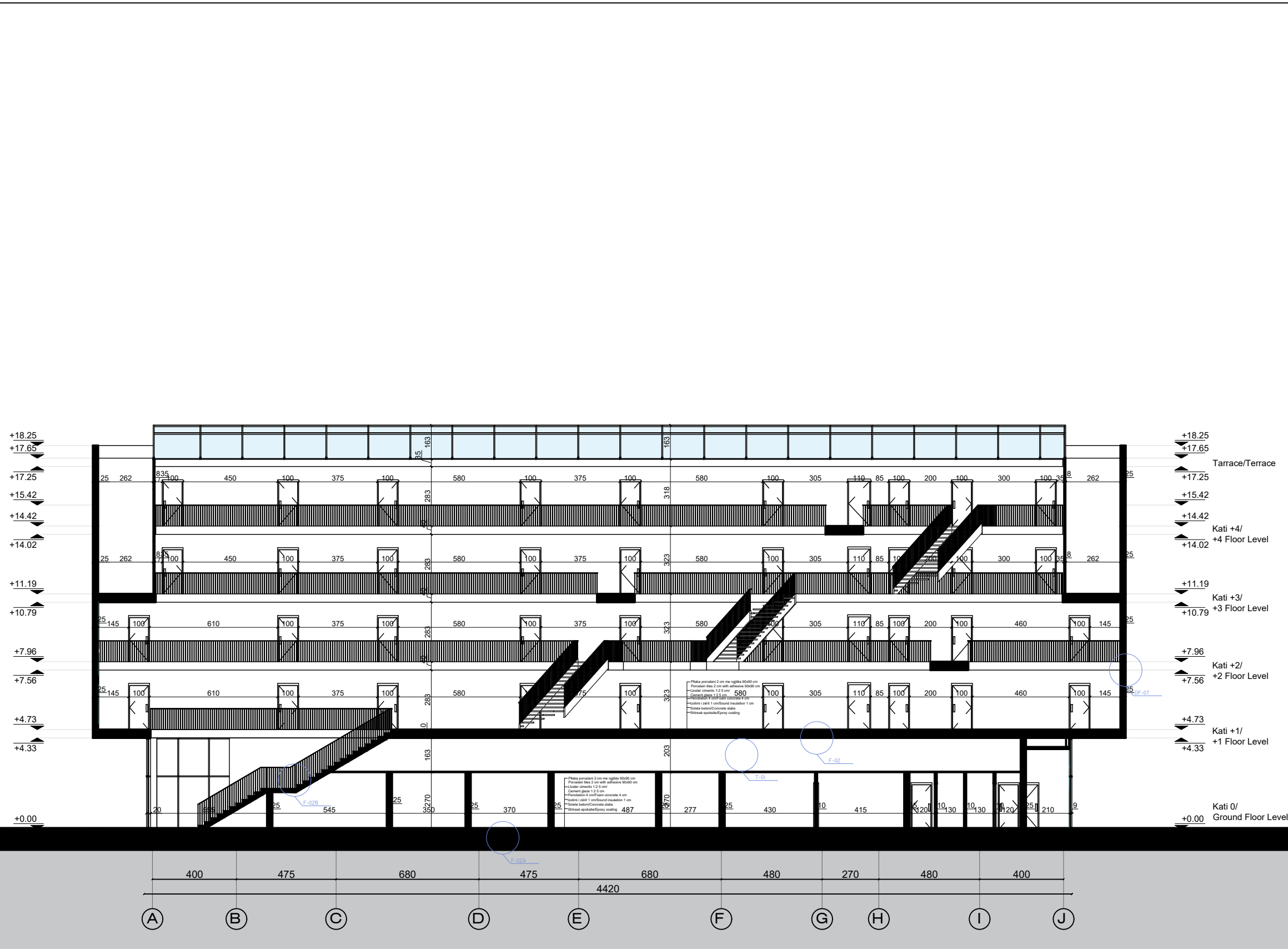

LEGJENDA/ Legenda:

SHENIME/ Notes:

PROJEKTI / Project:
 Ngritja e Infrastrukturës Arsimore të Liceut Franko-Shqiptar të Shkencave dhe Inovacionit, Bashkia Korçë / Establishment of the Educational Infrastructure of the Franco-Albanian Lyceum of Sciences and Innovation, Municipality of Korça

Klienti: FONDI SHQIPTAR I ZHVILLIMIT
 Client: ALBANIAN DEVELOPMENT FUND

IRI N.6844 Firma / Signature:
 Lexoj dhe aprovoj / I read and approve.

Local Architecture Office (LOC)
 Studio Lokale Arkitekture (VEND)
 Gent Agall

ARCHISPACE N.6732/14 Firma / Signature:
 Lexoj dhe aprovoj / I read and approve.

Local Architecture Office (LOC)
 Studio Lokale Arkitekture (VEND)
 Rais Petrela

SPHAERA N.4654/14 Firma / Signature:
 Lexoj dhe aprovoj / I read and approve.

Local Architecture Office (LOC)
 Studio Lokale Arkitekture (VEND)
 Ajkid Topore

LORENC BEGAJ K.2138/2 Firma / Signature:
 Lexoj dhe aprovoj / I read and approve.

AVE CONSULTING N.5628/12

Construction Studio
 Studio Konstruksioni
 Ing. Arben Dervishaj
 Ing. Ermal Spahiu
 Ing. Ina Hoxhaj

BURHAN TURKESHI K.1873/4 Firma / Signature:
 Lexoj dhe aprovoj / I read and approve.

ERMIR GJOKA M.1174/2

Hydro-Mechanical Engineering
 Inzhinieri Hidro-Mekanik dhe MNZ

BASHKIM SHAHINAJ E.0185/6 Firma / Signature:
 Lexoj dhe aprovoj / I read and approve.

BESART DALLIU E.1412/2

Electrical Engineering
 Inzhinieri Elektrik

ALL DIMENSIONS HAVE TO BE VERIFIED BY THE CONTRACTOR ON THE CONSTRUCTION SITE

TË GJITHA DIMENSIONET DUHET TË VERIFIKOHEN NGA KONTRAKTORI NË VEND

IMPORTANT: These drawings are property of IRI. Rruga Dervish HIMA, nr 8 kati i pare - 1001 TIRANA. Copy, multiplication or distribution without the written permission of IRI is prohibited.

E RËNDËSISHME: Këto vizatime janë pronë e IRI. Rruga DERVISH HIMA, nr 8 kati i parë - 1001 TIRANË. Kopjimi, shumfishimi apo shpërndarja e këtyre vizatimeve (apo pjesëve të tyre) pa lejen me shkrim të IRI është e ndaluar.

issuer A	plan number: A.00.1	TITULLI / Title: PRERJE A-A_ Konvikt/ SECTION A-A_Dormitory
--------------------	------------------------	---

Faza: LN	data: 2026	shkalla e vizatimit: 1:200	formati: A3
-------------	---------------	-------------------------------	----------------



LEGJENDA/ Legenda:

SHENIME/ Notes:

PROJEKTI / Project:
 Ngritja e Infrastrukturës Arsimore të Liceut Franko-Shqiptar të Shkencave dhe Inovacionit, Bashkia Korçë / Establishment of the Educational Infrastructure of the Franco-Albanian Lyceum of Sciences and Innovation, Municipality of Korça

Klienti: FONDI SHQIPTAR I ZHVILLIMIT
 Client: ALBANIAN DEVELOPMENT FUND

IRI Local Architecture Office (L.O.C) Studio Lokale Arkitekture (VEND) Gent Agall	N.6844	Firma / Signature: Lexoj dhe aprovoj / I read and approve.
ARCHISPACE Local Architecture Office (L.O.C) Studio Lokale Arkitekture (VEND) Rais Petrela	N.6732/14	Firma / Signature: Lexoj dhe aprovoj / I read and approve.
SPHAERA Local Architecture Office (L.O.C) Studio Lokale Arkitekture (VEND) Ajdin Topore	N.4654/14	Firma / Signature: Lexoj dhe aprovoj / I read and approve.
LORENC BEGAJ AVE CONSULTING Construction Studio Studio Konstruksioni ing. Arben Dervishaj ing. Ermal Spahiu ing. Ina Hotaj	K.2138/2 N.5628/12	Firma / Signature: Lexoj dhe aprovoj / I read and approve.
BURHAN TURKESHI ERMIR GJOKA Hydro-Mechanical Engineering Inzhinieri Hidro-Mekanik dhe MNZ	K.1873/4 M.1174/2	Firma / Signature: Lexoj dhe aprovoj / I read and approve.
BASHKIM SHAHINAJ BESART DALLIU Electrical Engineering Inzhinieri Elektrik	E.0185/6 E.1412/2	Firma / Signature: Lexoj dhe aprovoj / I read and approve.

ALL DIMENSIONS HAVE TO BE VERIFIED BY THE CONTRACTOR ON THE CONSTRUCTION SITE		TË GJITHA DIMENSIONET DUHET TË VERIFIKOHEN NGA KONTRAKTORI NË VEND	
IMPORTANT: These drawings are property of IRI. Rruga DERVISH HIMA, nr 8 kati i pare - 1001 TIRANA. Copy, multiplication or distribution inbetween parties of these plans (or any part of it) without written permission of IRI is prohibited.		E RËNDËSISHME: Këto vizatime janë pronë e IRI. Rruga DERVISH HIMA, nr 8 kati i parë - 1001 TIRANË. Kopjimi, shumfishimi apo shpërndarja e këtyre vizatimeve (apo pjesëve të tyre) pa lejen me shkrim të IRI është e ndaluar.	
issuer A	plan number: A.00.1	TITULLI / Title: FASADE VERIORE _ Konvikti/ NORTH FACADE_Dormitory	
Faza: LN	data: 2026	shkalla e vizatimit: 1:200	formati: A3

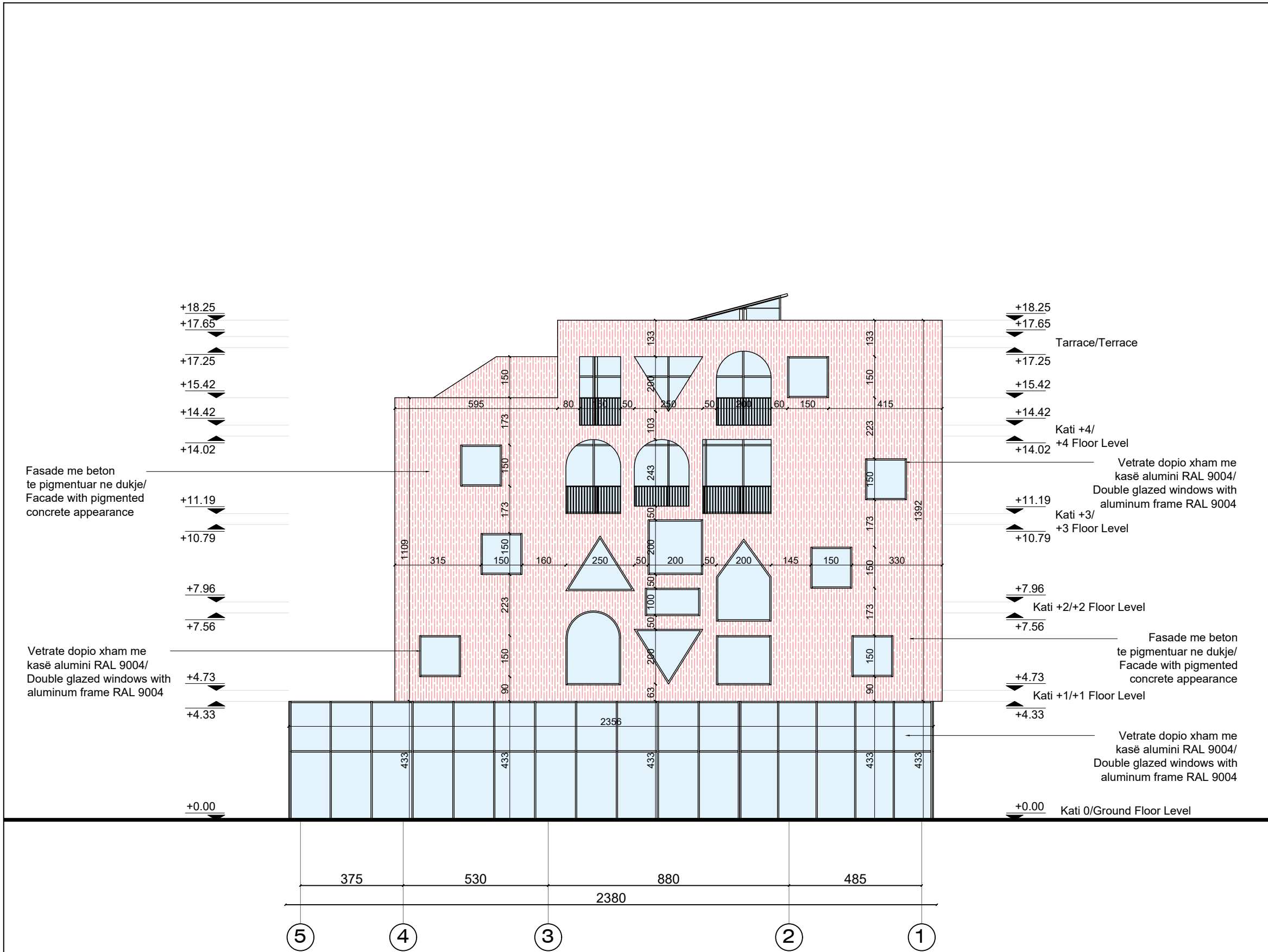

LEGJENDA/ Legenda:

SHENIME/ Notes:

PROJEKTI / Project:
 Ngritja e Infrastrukturës Arsimore të Liceut Franko-Shqiptar të Shkencave dhe Inovacionit, Bashkia Korçë / Establishment of the Educational Infrastructure of the Franco-Albanian Lyceum of Sciences and Innovation, Municipality of Korça

Klienti: FONDI SHQIPTAR I ZHVILLIMIT
 Client: ALBANIAN DEVELOPMENT FUND

IRI Local Architecture Office (LOC) Studio Lokale Arkitekture (VEND) Gent Agall	N.6844	Firma / Signature: Lexoj dhe aprovoj / I read and approve.
ARCHISPACE Local Architecture Office (LOC) Studio Lokale Arkitekture (VEND) Rais Petrela	N.6732/14	Firma / Signature: Lexoj dhe aprovoj / I read and approve.
SPHAERA Local Architecture Office (LOC) Studio Lokale Arkitekture (VEND) Ajdin Topore	N.4654/14	Firma / Signature: Lexoj dhe aprovoj / I read and approve.
LORENC BEGAJ AVE CONSULTING Construction Studio Studio Konstruksioni ing. Arben Dervishaj ing. Ermal Spahiu ing. Ina Hotaj	K.2138/2 N.5628/12	Firma / Signature: Lexoj dhe aprovoj / I read and approve.
BURHAN TURKESHI ERMIR GJOKA Hydro-Mechanical Engineering Inzhinieri Hidro-Mekanik dhe MNZ	K.1873/4 M.1174/2	Firma / Signature: Lexoj dhe aprovoj / I read and approve.
BASHKIM SHAHINAJ BESART DALLIU Electrical Engineering Inzhinieri Elektrik	E.0185/6 E.1412/2	Firma / Signature: Lexoj dhe aprovoj / I read and approve.

ALL DIMENSIONS HAVE TO BE VERIFIED BY THE CONTRACTOR ON THE CONSTRUCTION SITE		TË GJITHA DIMENSIONET DUHET TË VERIFIKOHEN NGA KONTRAKTORI NË VEND	
IMPORTANT: These drawings are property of IRI. Rruga DERSH HIMA, nr 8 kati i pare - 1001 TIRANA. Copy, multiplication or distribution inbetween parties of these plans (or any part of it) without written permission of IRI is prohibited.		E RËNDËSISHME: Këto vizatime janë pronë e IRI, Rruga DERSH HIMA, nr 8 kati i parë - 1001 TIRANË. Kopjimi, shumfishimi apo shpërndarja e këtyre vizatimeve (apo pjesëve të tyre) pa lejen me shkrim të IRI është e ndaluar.	
issuer A	plan number: A.00.1	TITULLI / Title: FASADE LINDORE _ Konvikti/ EAST FACADE_Dormitory	
Faza: LN	data: 2026	shkalla e vizatimit: 1:150	formati: A3

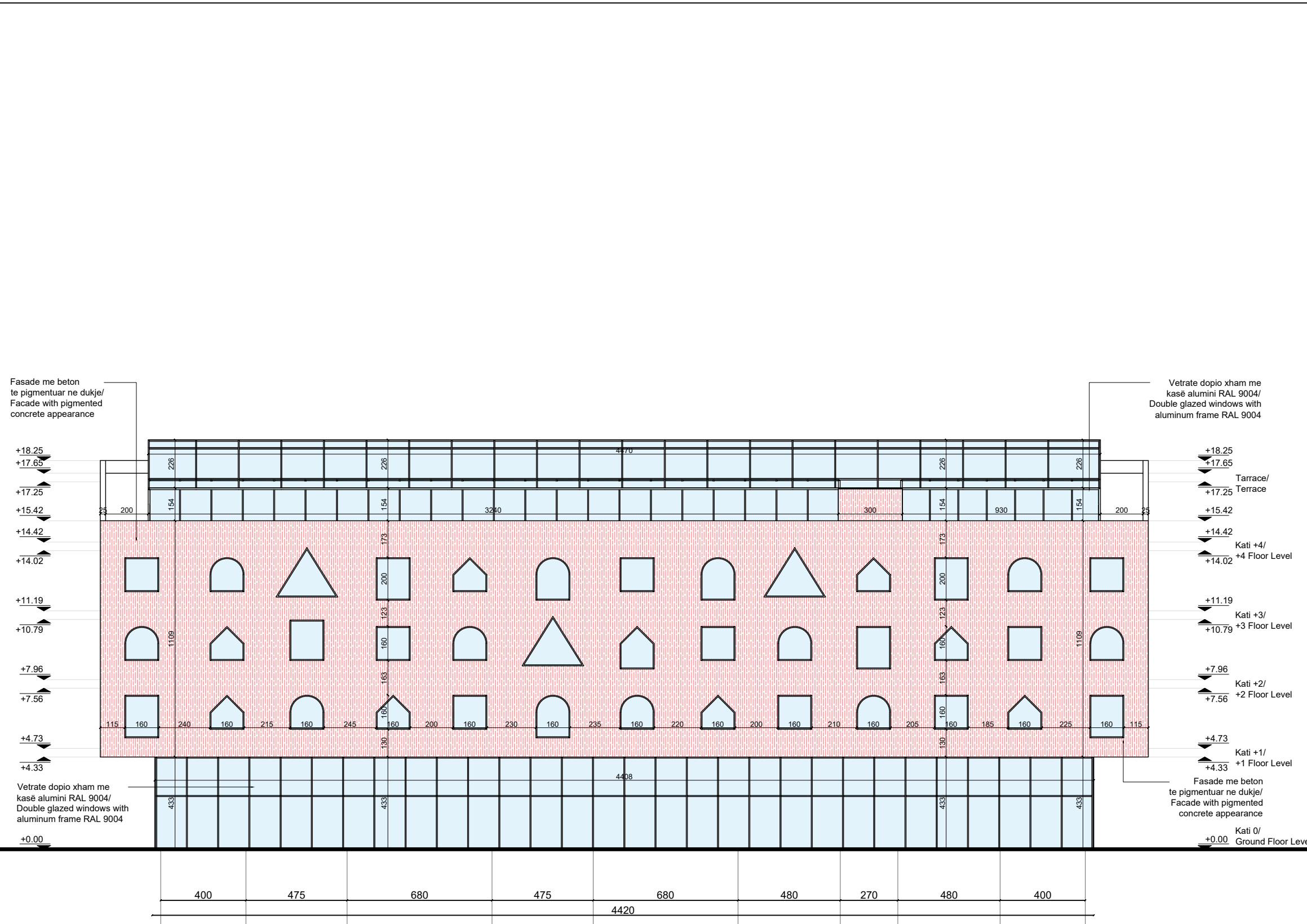

LEGJENDA/ Legenda:

SHENIME/ Notes:

PROJEKTI / Project:
Ngritja e Infrastrukturës Arsimore të Liceut Franko-Shqiptar të Shkencave dhe Inovacionit, Bashkia Korçë / Establishment of the Educational Infrastructure of the Franco-Albanian Lyceum of Sciences and Innovation, Municipality of Korça

Klienti: FONDI SHQIPTAR I ZHVILLIMIT
Client: ALBANIAN DEVELOPMENT FUND

IRI Local Architecture Office (LOC) Studio Lokale Arkitekture (VEND) Gent Agall	N.6844	Firma / Signature: Lexoj dhe aprovoj / I read and approve.
ARCHISPACE Local Architecture Office (LOC) Studio Lokale Arkitekture (VEND) Rais Petrela	N.6732/14	Firma / Signature: Lexoj dhe aprovoj / I read and approve.
SPHAERA Local Architecture Office (LOC) Studio Lokale Arkitekture (VEND) Akid Topore	N.4654/14	Firma / Signature: Lexoj dhe aprovoj / I read and approve.

LORENC BEGAJ AVE CONSULTING Construction Studio Studio Konstruksioni ing. Arben Dervishaj ing. Ermal Spahiu ing. Ina Hotaj	K.2138/2 N.5628/12	Firma / Signature: Lexoj dhe aprovoj / I read and approve.
BURHAN TURKESHI ERMIR GJOKA Hydro-Mechanical Engineering Inzhinieri Hidro-Mekanik dhe MNZ	K.1873/4 M.1174/2	Firma / Signature: Lexoj dhe aprovoj / I read and approve.
BASHKIM SHAHINAJ BESART DALLIU Electrical Engineering Inzhinieri Elektrik	E.0185/6 E.1412/2	Firma / Signature: Lexoj dhe aprovoj / I read and approve.

ALL DIMENSIONS HAVE TO BE VERIFIED BY THE CONTRACTOR ON THE CONSTRUCTION SITE
IMPORTANT: These drawings are property of IRI. Rruga DERSH HIMA, nr 8 kati i pare - 1001 TIRANA. Copy, multiplication or distribution inbetween parties of these plans (or any part of it) without written permission of IRI is prohibited.

TË GJITHA DIMENSIONET DUHET TË VERIFIKOHEN NGA KONTRAKTORI NË VËND
E RËNDËSISHME: Këto vizatime janë pronë e IRI. Rruga DERSH HIMA, nr 8 kati i parë - 1001 TIRANË. Kopjimi, shumëfishimi apo shpërndarja e këtyre vizatimeve (apo pjesëve të tyre) pa lejen me shkrim të IRI është e ndaluar.

issuer A	plan number: A.00.1	TITULLI / Title: FASADE JUGORE _ Konvikti/ SOUTH FACADE_Dormitory	
Faza: LN	data: 2026	shkalla e vizatimit: 1:200	formati: A3



Vetrate dopio xham me kasë alumini RAL 9004/
Double glazed windows with aluminum frame RAL 9004

Fasade me beton te pigmentuar ne dukje/
Facade with pigmented concrete appearance

Fasade me beton te pigmentuar ne dukje/
Facade with pigmented concrete appearance

Vetrate dopio xham me kasë alumini RAL 9004/
Double glazed windows with aluminum frame RAL 9004

Vetrate dopio xham me kasë alumini RAL 9004/
Double glazed windows with aluminum frame RAL 9004

Kati 0/Ground Floor Level

Kati +1/
+1 Floor Level

Kati +2/
+2 Floor Level

Kati +3/
+3 Floor Level

Kati +4/
+4 Floor Level

Terrace/
Terrace

LEGJENDA/ Legenda:

SHENIME/ Notes:

PROJEKTI / Project:
Ngritja e Infrastrukturës Arsimore të Liceut Franko-Shqiptar të Shkencave dhe Inovacionit, Bashkia Korçë / Establishment of the Educational Infrastructure of the Franco-Albanian Lyceum of Sciences and Innovation, Municipality of Korça

Klienti: FONDI SHQIPTAR I ZHVILLIMIT
Client: ALBANIAN DEVELOPMENT FUND

IRI Local Architecture Office (LOC) Studio Lokale Arkitekture (VEND) Gent Agall	N.6844	Firma / Signature: Lexoj dhe aprovoj / I read and approve.
ARCHISPACE Local Architecture Office (LOC) Studio Lokale Arkitekture (VEND) Rais Petrela	N.6732/14	Firma / Signature: Lexoj dhe aprovoj / I read and approve.
SPHAERA Local Architecture Office (LOC) Studio Lokale Arkitekture (VEND) Ajdin Topore	N.4654/14	Firma / Signature: Lexoj dhe aprovoj / I read and approve.
LORENC BEGAJ AVE CONSULTING Construction Studio Studio Konstruksioni ing. Arben Dervishaj ing. Ermal Spahiu ing. Ina Hotaj	K.2138/2 N.5628/12	Firma / Signature: Lexoj dhe aprovoj / I read and approve.
BURHAN TURKESHI ERMIR GJOKA Hydro-Mechanical Engineering Inzhinieri Hidro-Mekanik dhe MNZ	K.1873/4 M.1174/2	Firma / Signature: Lexoj dhe aprovoj / I read and approve.
BASHKIM SHAHINAJ BESART DALLIU Electrical Engineering Inzhinieri Elektrik	E.0185/6 E.1412/2	Firma / Signature: Lexoj dhe aprovoj / I read and approve.

ALL DIMENSIONS HAVE TO BE VERIFIED BY THE CONTRACTOR ON THE CONSTRUCTION SITE
IMPORTANT: These drawings are property of IRI. Rruga DERSH HIMA, nr 8 kati i pare - 1001 TIRANA. Copy, multiplication or distribution inbetween parties of these plans (or any part of it) without written permission of IRI is prohibited.

TË GJITHA DIMENSIONET DUHET TË VERIFIKOHEN NGA KONTRAKTORI NË VEND
E RËNDËSISHME: Këto vizatime janë pronë e IRI. Rruga DERSH HIMA, nr 8 kati i parë - 1001 TIRANË. Kopjimi, shumfishimi apo shpërndarja e këtyre vizatimeve (apo pjesëve të tyre) pa lejen me shkrim të IRI është e ndaluar.

issuer A	plan number: A.00.1	TITULLI / Title: FASADE PERENDIMORE _ Konvikti/ WEST FACADE_Dormitory	
Faza: LN	data: 2026	shkalla e vizatimit: 1:150	formati: A3

F-01 PORCELAIN TILES

- Porcelain tiles 2 cm glued 90x90 cm
- Screed 1:2 5 cm
- Foam concrete 5 cm
- Acoustic insulation 1 cm
- Concrete slab
- epoxy layer

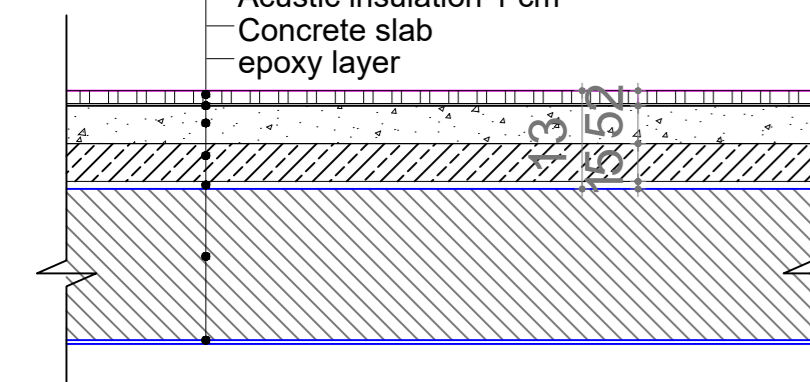

F-01A PORCELAIN TILES GROUND FLOOR

- Porcelain tiles 2 cm glued
- Screed 1:2 5 cm
- Foam concrete 6 cm
- Concrete hydraulic slab 20 cm
- Gravel
- Natural soil

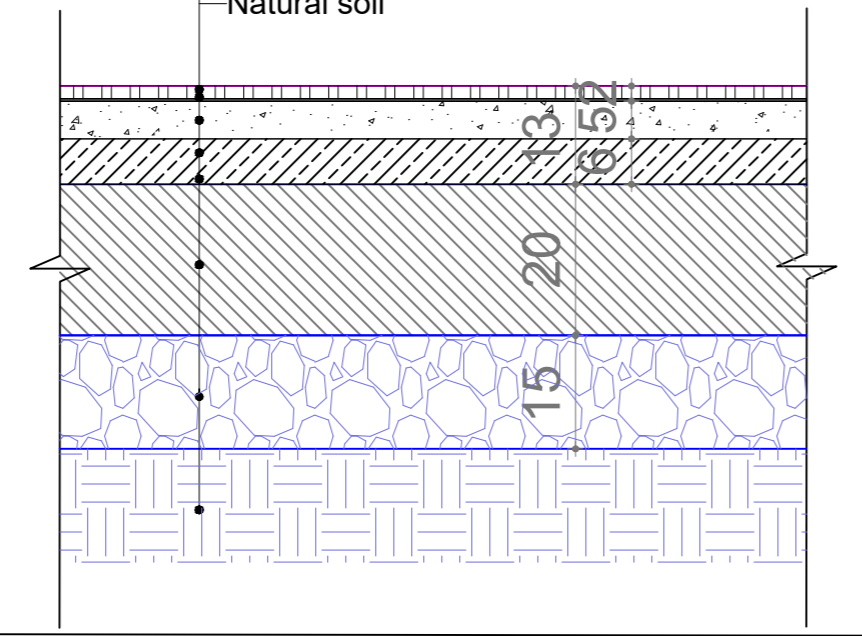

F-02 POLISHED CONCRETE

- Polished concrete layer 12cm
- Sound insulation 1 cm
- Concrete slabs
- Epoxy layer

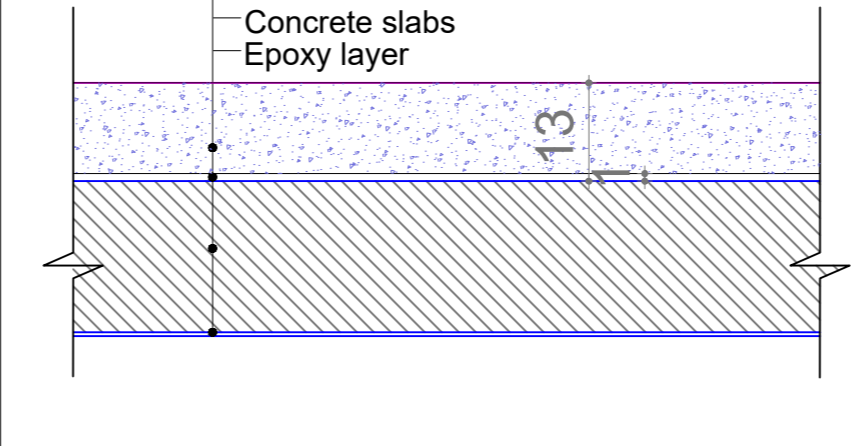

F-02A POLISHED CONCRETE GROUND FLOOR

- Polished concrete layer 13cm
- Hydraulic concrete slabs 20 cm
- Gravel filling
- Natural soil

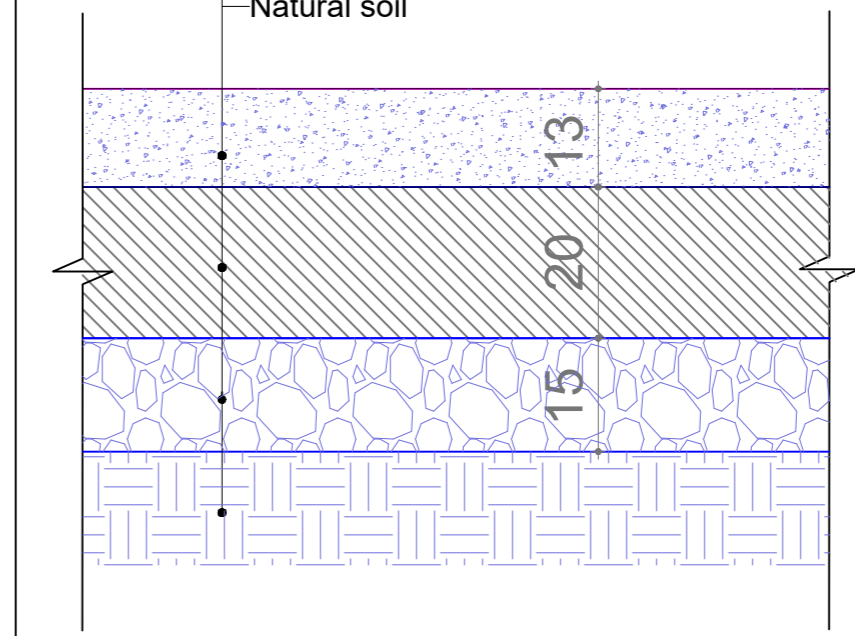

F-03 PORCELAIN TILES FOR TOILET

- Porcelain tiles 2 cm glued
- Waterproof bicomponent layer
- Screed 1:2 4 cm
- Foam concrete 6 cm
- Acoustic insulation 1 cm
- Concrete slab
- Epoxy layer

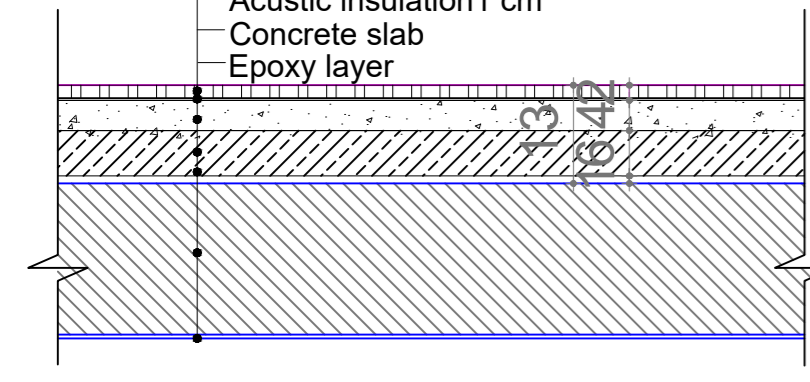

F-05 CLEAR CONCRETE WITH EPOXY LAYER FOR THE TARRACES

- Epoxy layer
- Clear concrete layer 5 cm
- Waterproof PVC
- Screed 1:2 5 cm
- Foam concrete 1% 5 to 10 cm
- Thermal insulation XPS 10 cm
- Concrete slab
- Epoxy layer i=1%

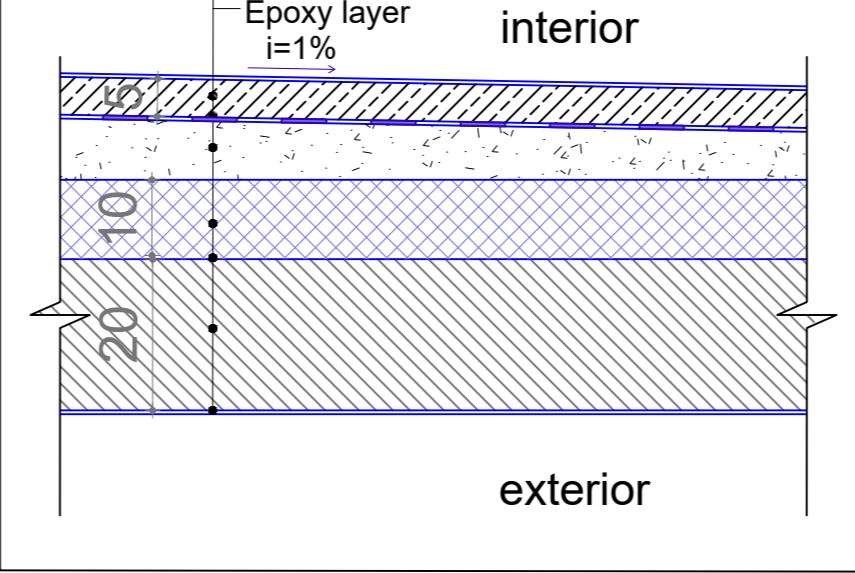

F-05 CLEAR CONCRETE WITH EPOXY LAYER FOR THE EXTERIOR STAIRS

- Epoxy layer
- Clear concrete layer
- Prototon 1.5 cm with net
- Thermal insulation XPS 5 cm (waterproof)
- Waterproof bicomponent layer with glass textile net
- Structure, concrete stairs 20 cm
- Epoxy layer

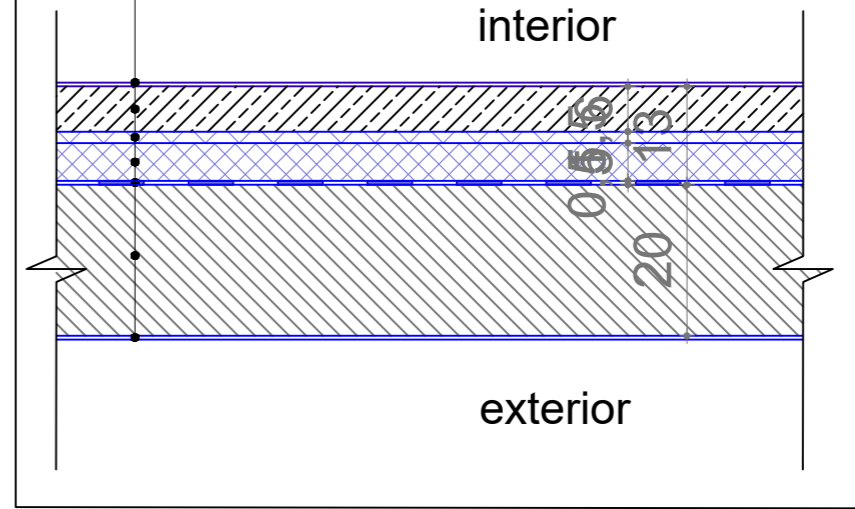

F-04 CONCRETE WITH QUARTZ AND CEMENT IN TECHNICAL ROOM

- Industrial concrete treated with quartz and cement, with a 10-13 cm helicopter
- PVC layer
- Hydraulic concrete slab 20 cm
- Gravel
- Natural soil

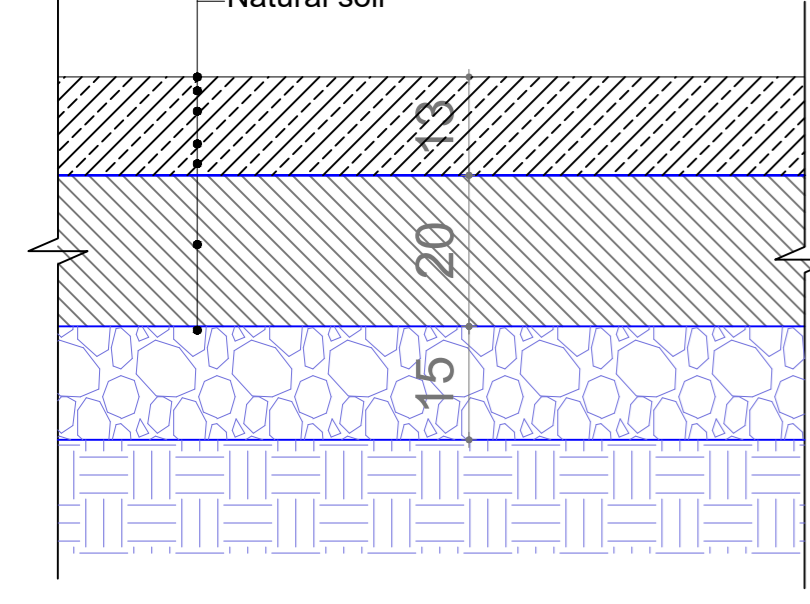

F-04A CONCRETE WITH QUARTZ AND CEMENT IN BASEMENT

- Industrial concrete treated with quartz and cement, with a 10-13 cm helicopter
- PVC layer
- Concrete layer 10 cm
- Gravel 15 cm
- Natural soil

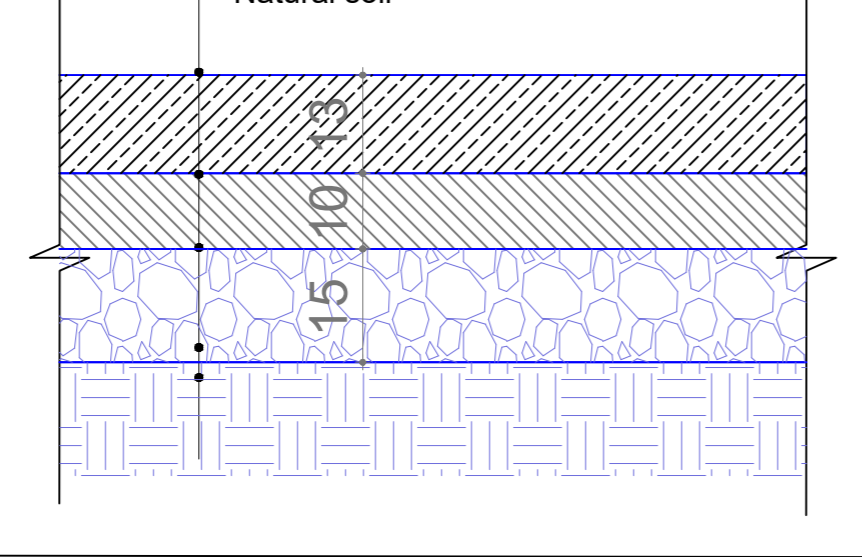

F-08 CONCRETE WIRTH QUARTZ AND CEMENT FOR STAIRS

- Industrial concrete treated with quartz and cement, with a 7 cm helicopter
- PVC layer
- Concrete slab

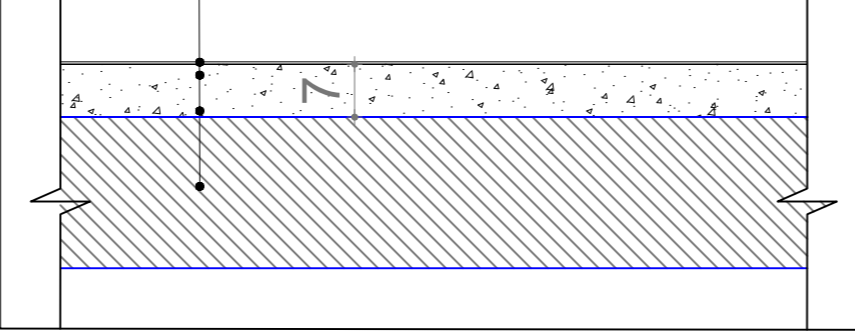

F-09 LEVELED ROOF CONCRETE

- Waterproof PVC
- Screed 1:2 5 cm
- Foam concrete 1% 5 to 10 cm
- Thermal insulation 10 cm
- Concrete slab

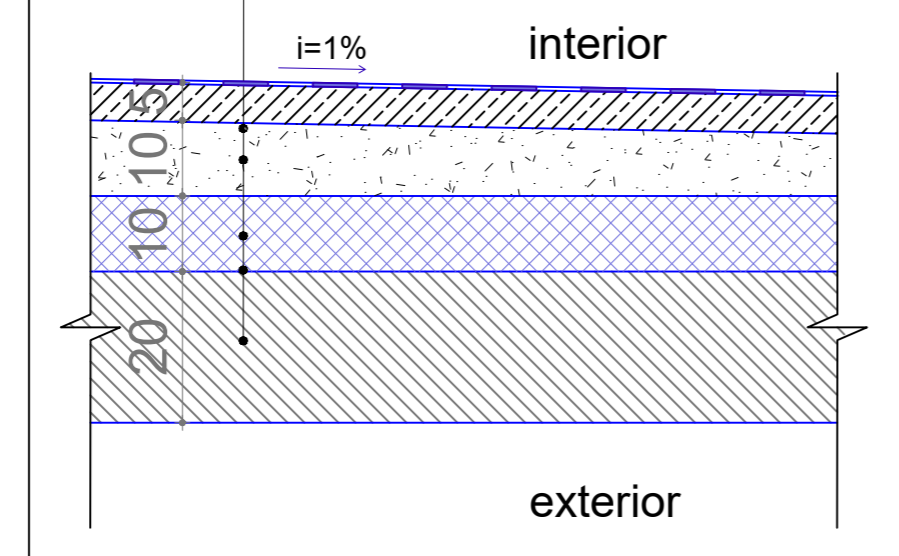

F-10 CONCRETE WITH EPOXY LAYER

- Epoxy layer
- Structure concrete 20 cm
- Epoxy layer

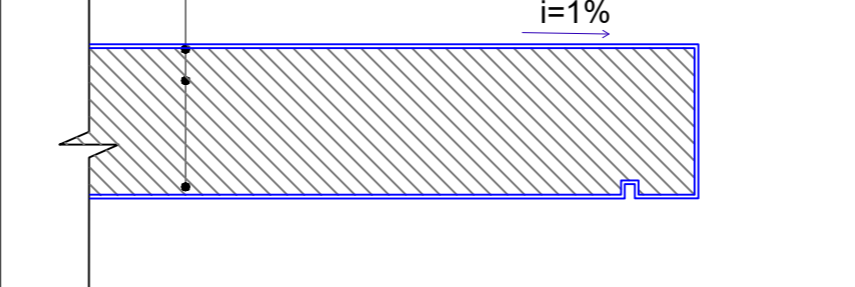

F-07 MARBLE STAIRS

- Marble tile 2 cm glued
- Screed 1:2 5 cm
- Concrete slab
- Epoxy layer

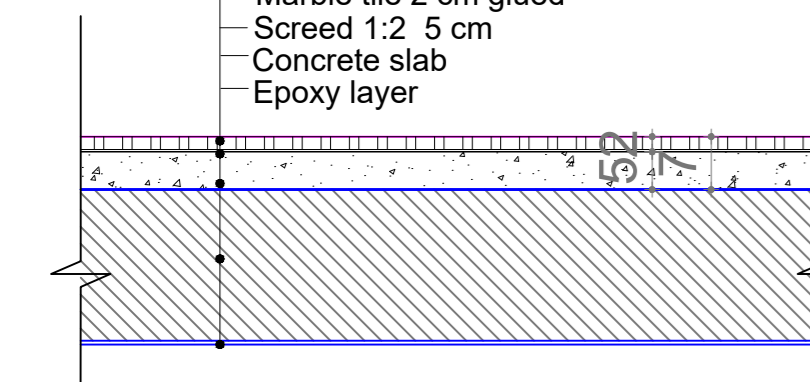

F-11 DETAIL OF TECHNOLOGICAL SUSPICION

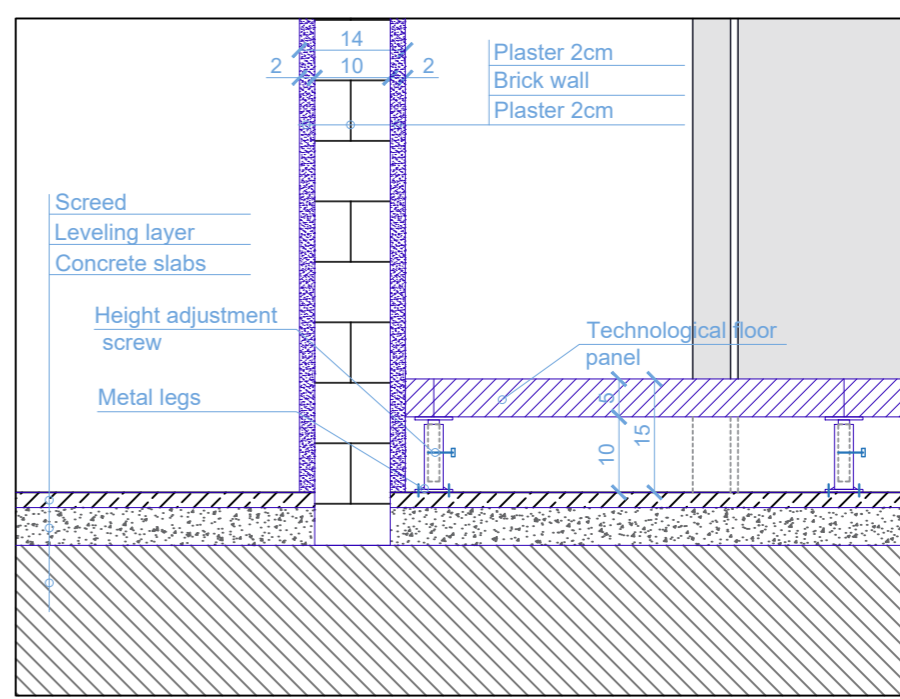

PROJEKTI / Projekt:
Ngritja e Infrastrukturës Arsimore të Liceut Franko-Shqiptar të Shkencave dhe Inovacionit, Bashkia Korçë / Establishment of the Educational Infrastructure of the Franco-Albanian Lyceum of Sciences and Innovation, Municipality of Korça

Klienti: FONDI SHQIPTAR I ZHVILLIMIT
Client: ALBANIAN DEVELOPMENT FUND

iRI Local Architecture Office (LOC) Studio Lokale Arkitekture (VENO) Gëzim Dajçi	N.6844	Firma / Signature: Lexoj dhe aprovoj / I read and approve.
ARCHISPACE Local Architecture Office (LOC) Studio Lokale Arkitekture (VENO) Riçe Pajtim	N.6732/14	Firma / Signature: Lexoj dhe aprovoj / I read and approve.
SPHAERA Local Architecture Office (LOC) Studio Lokale Arkitekture (VENO) Adrian Topani	N.4654/14	Firma / Signature: Lexoj dhe aprovoj / I read and approve.
LORENC BEGAJ AVE CONSULTING Consultor Shkencë (VENO) Ing. Arben Derwishaj Ing. Enxhel Dajçi Ing. Mirza Haxhiu	K.2138/2 N.5628/12	Firma / Signature: Lexoj dhe aprovoj / I read and approve.
BURHAN TURKESHI ERMIR GJOKA Mechanical Engineering Inzhineri Haki-Mehmeti dhe MZ	K.1873/4 M.1174/2	Firma / Signature: Lexoj dhe aprovoj / I read and approve.
BASHKIM SHAHINAJ BESART DALLIU Electrical Engineering Inzhineri Besart Dalli	E.0185/6 E.1412/2	Firma / Signature: Lexoj dhe aprovoj / I read and approve.

M -01 CONCRETE WALL

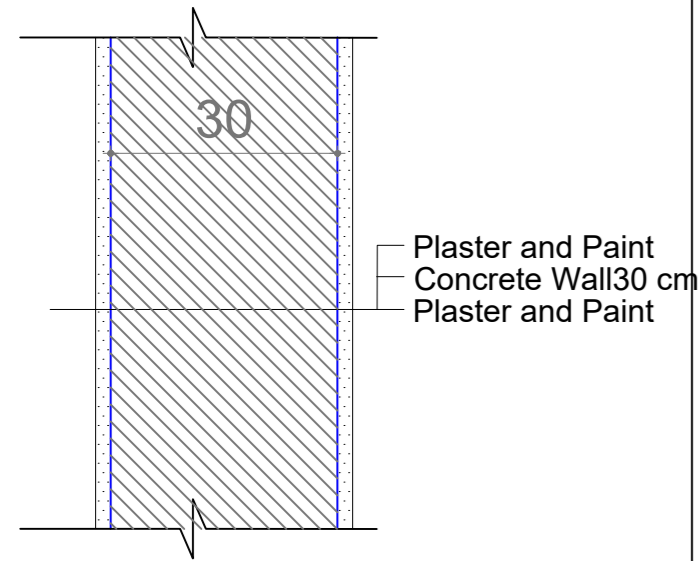

M -02 A BRICK WALL
TECHNICAL ROOM

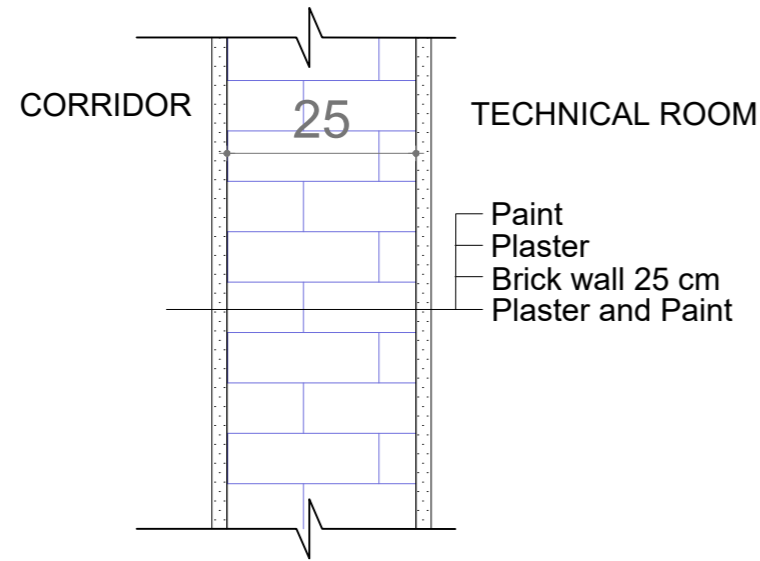

M -02 B Brick Wall
For Toilets

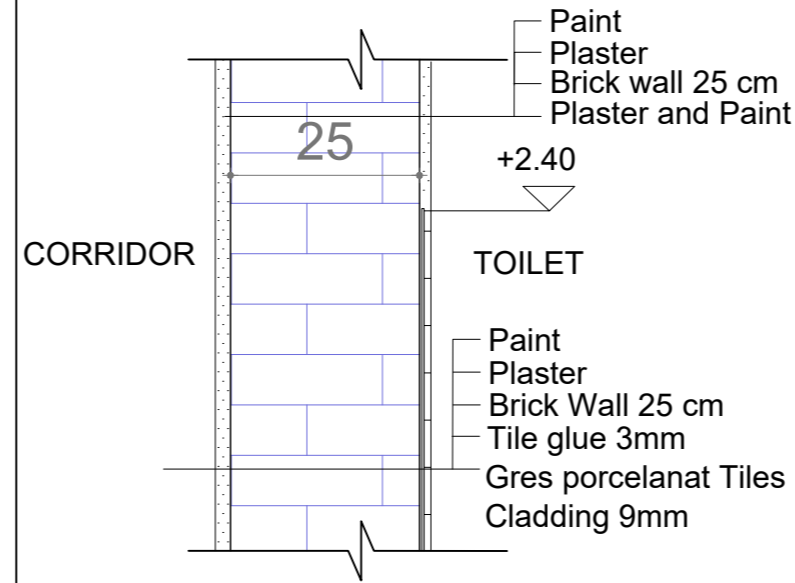

M -03 DOUBLE BRICK WALL

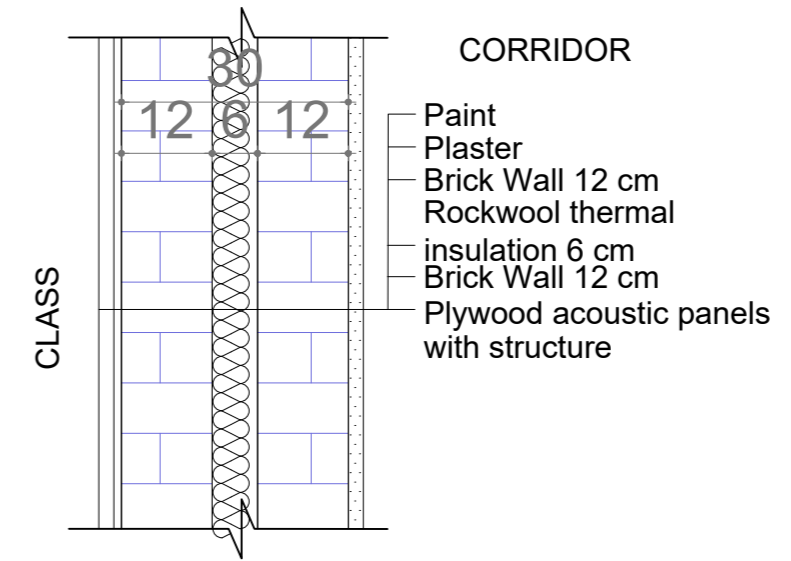

M -04 DRYWALL

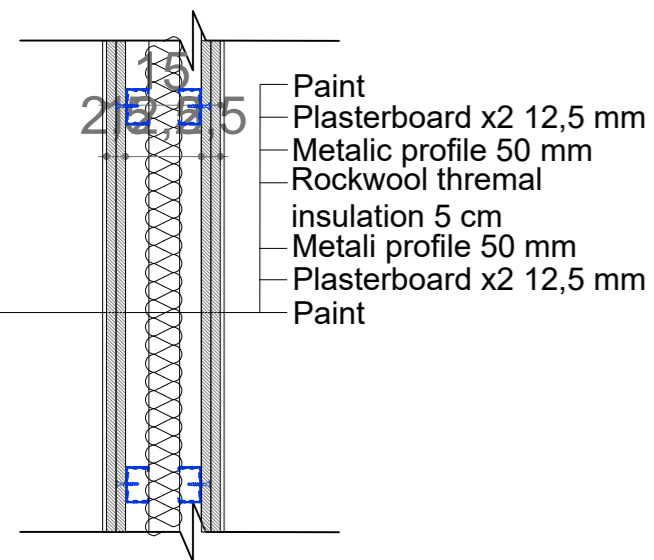

M -05 GKF PLASTERBOARD
HALF DRYWALL

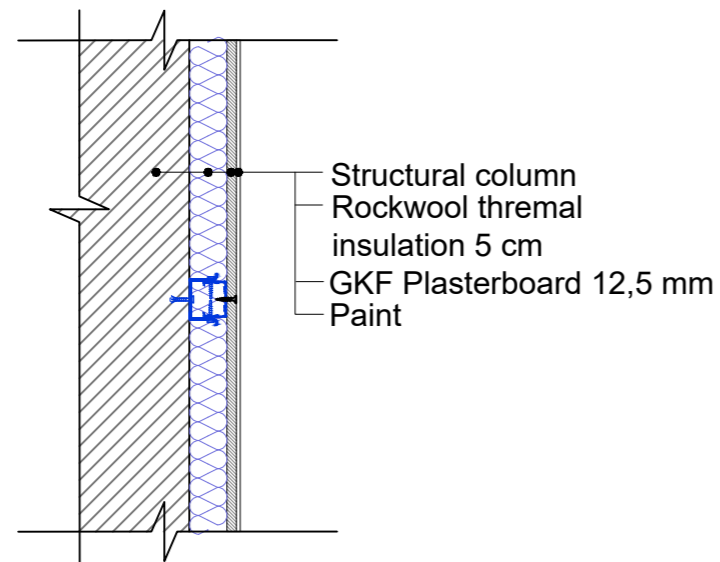

M -06 CEMENTBOARD
DRYWALL

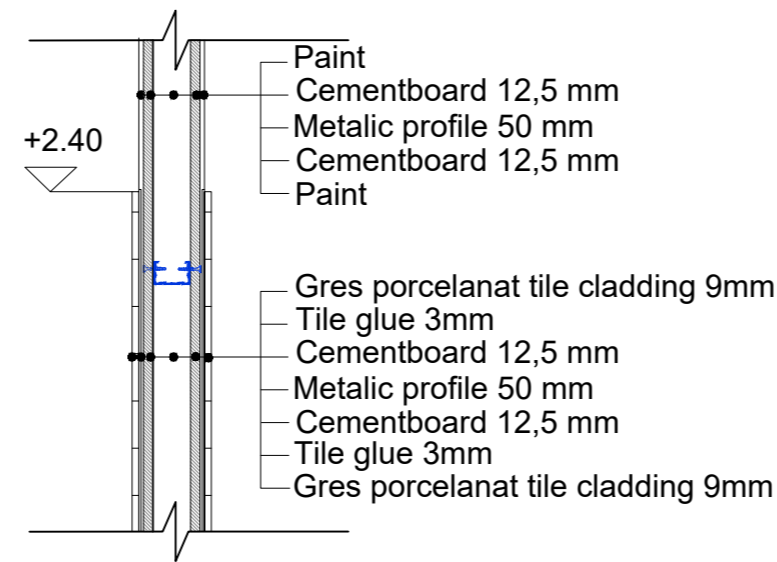

D -05 CONECTION OF DRYWALL
WITH FACADE DETAIL

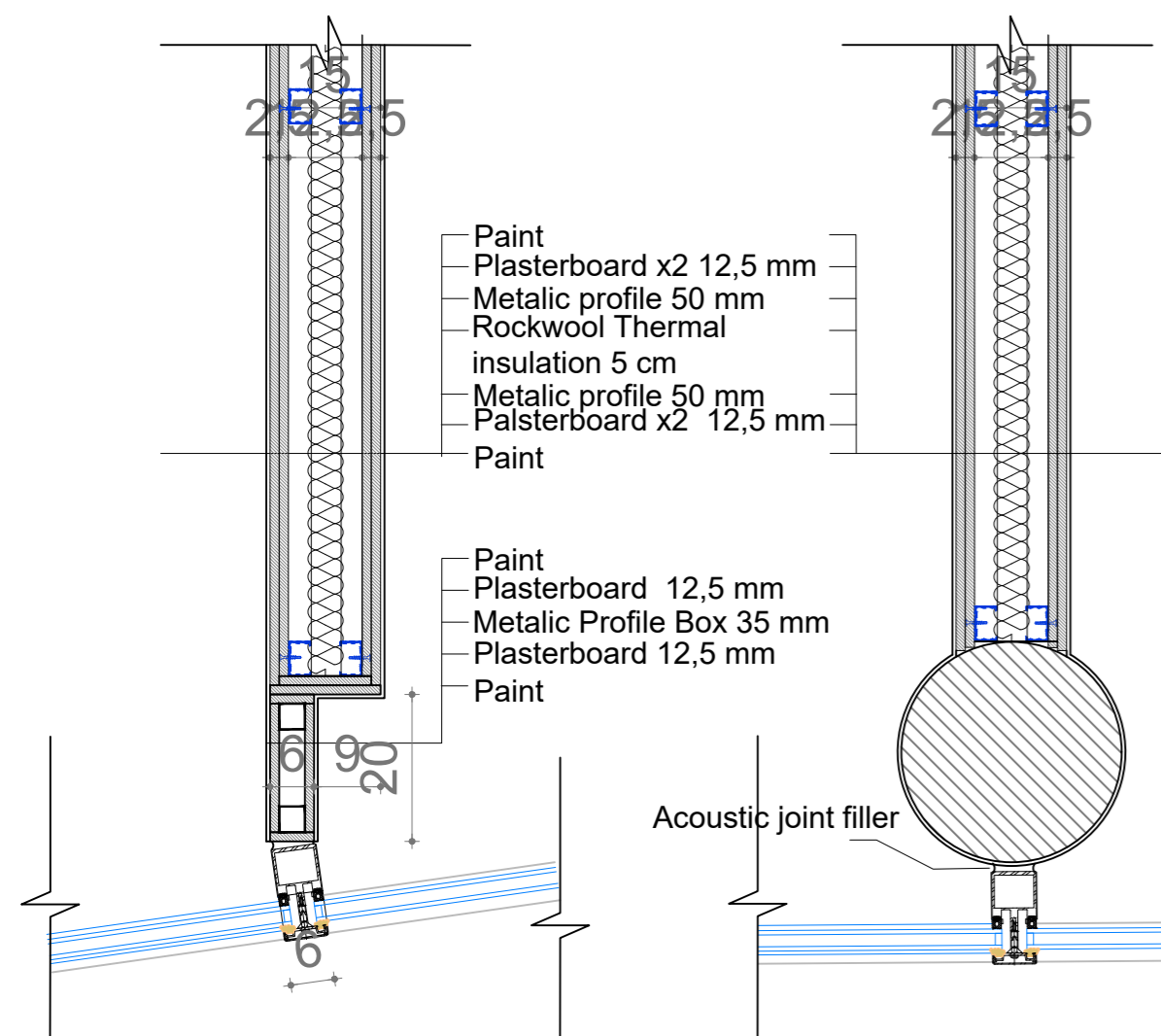

D -06 CONECTION OF BRICKWALL
WITH FACADE DETAIL

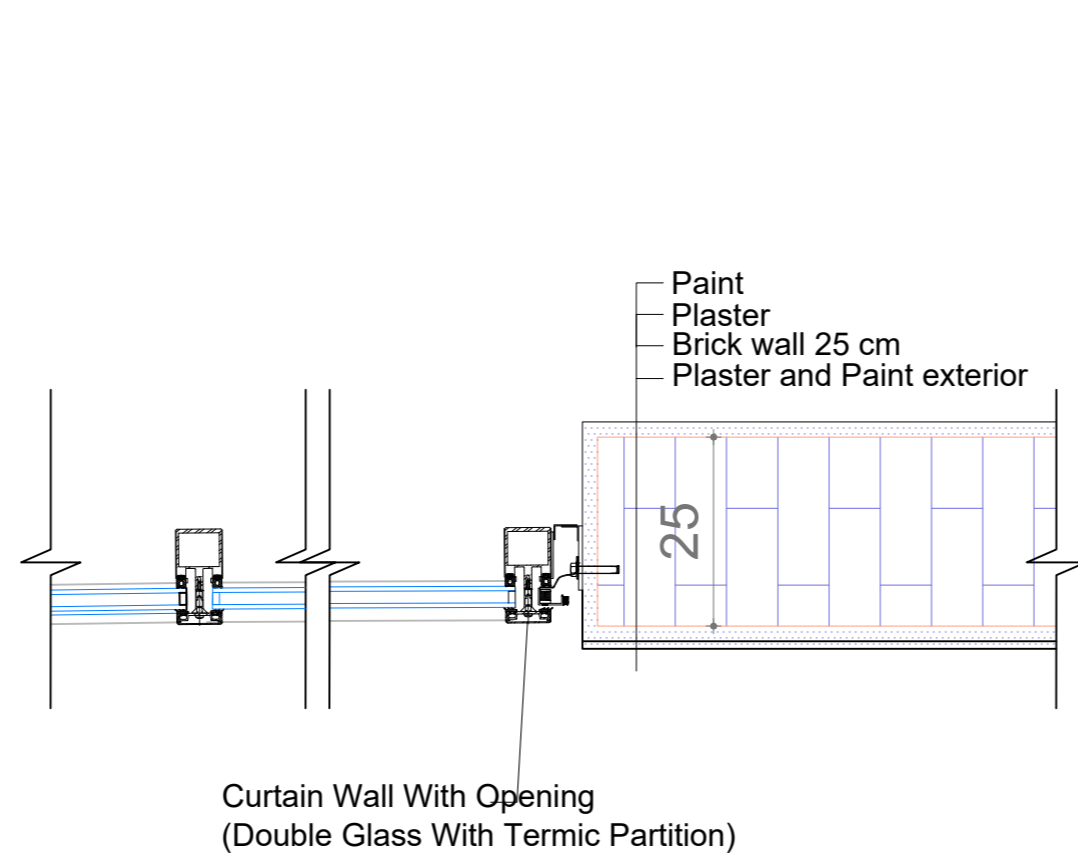

M -08 GLASS PARTITION

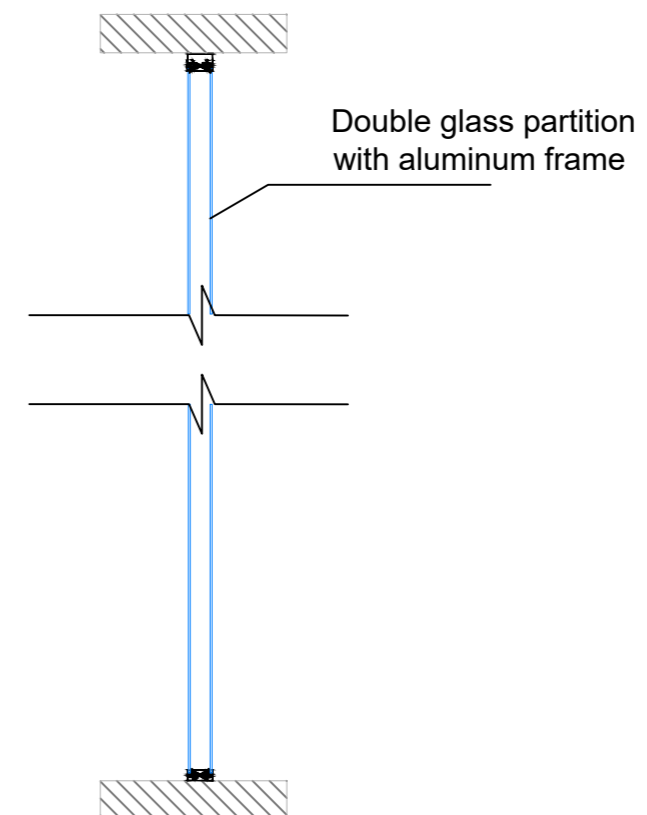

PROJEKTI / Project:
Ngritja e Infrastrukturës Arsimore të Liceut Franko-Shqiptar të Shkencave dhe Inovacionit, Bashkia Korçë / Establishment of the Educational Infrastructure of the Franco-Albanian Lyceum of Sciences and Innovation, Municipality of Korçë

Klienti: FONDI SHQIPTAR I ZHVILLIMIT
Client: ALBANIAN DEVELOPMENT FUND

IRI Local Architecture Office (L.O.C) Studio Lokale Arkitekture (VEND) Gent Nijazi	N.6844	Firma / Signature: Lexoj dhe aprovoj / I read and approve.
ARCHISPACE Local Architecture Office (L.O.C) Studio Lokale Arkitekture (VEND) Riza Piro	N.6732/14	Firma / Signature: Lexoj dhe aprovoj / I read and approve.
SPHAERA Local Architecture Office (L.O.C) Studio Lokale Arkitekture (VEND) Alban Topani	N.4654/14	Firma / Signature: Lexoj dhe aprovoj / I read and approve.
LORENC BEGAJ AVE CONSULTING Consultorë Shkencë Konstruktive (ng. Arden Derani) (ng. Enver Shkupi) (ng. Miri Haxhi)	K.2138/2 N.5628/12	Firma / Signature: Lexoj dhe aprovoj / I read and approve.
BURHAN TURKESHI ERMIR GJOKA Mechanical Engineering Insheni Habi-Merkez dhe MZ	K.1873/4 M.1174/2	Firma / Signature: Lexoj dhe aprovoj / I read and approve.
BASHKIM SHAHINAJ BESART DALLIU Electrical Engineering Insheni Dikela	E.0185/6 E.1412/2	Firma / Signature: Lexoj dhe aprovoj / I read and approve.

ALL DIMENSIONS HAVE TO BE VERIFIED BY THE CONTRACTOR ON THE CONSTRUCTION SITE.
SHËRBUESIT: Këto dimensionet janë pronë të IRI, Rrugës DERVISHI HIMA, nr 8 kati i parë - 1001 TIRANë, Copy, multiplication or distribution in other parts of these plans (or any part of it) without written permission of IRI is prohibited.

TË GJITHA DIMENSIONET DUHET TË VERIFIKOHEN NGA KONTRAKTORI NË VEND.
E RËNDËSONDËSHË: Këto dimensionet janë pronë të IRI, Rrugës DERVISHI HIMA, nr 8 kati i parë - 1001 TIRANë, Kopimi, shumëllojshmëri apo shpërndarja e këtyre vizatimeve (apo pjesëve të tyre) pa lejen me shkrim të IRI-së është e ndaluar.

FACADE DETAILS

DF-04 FACADE DETAIL

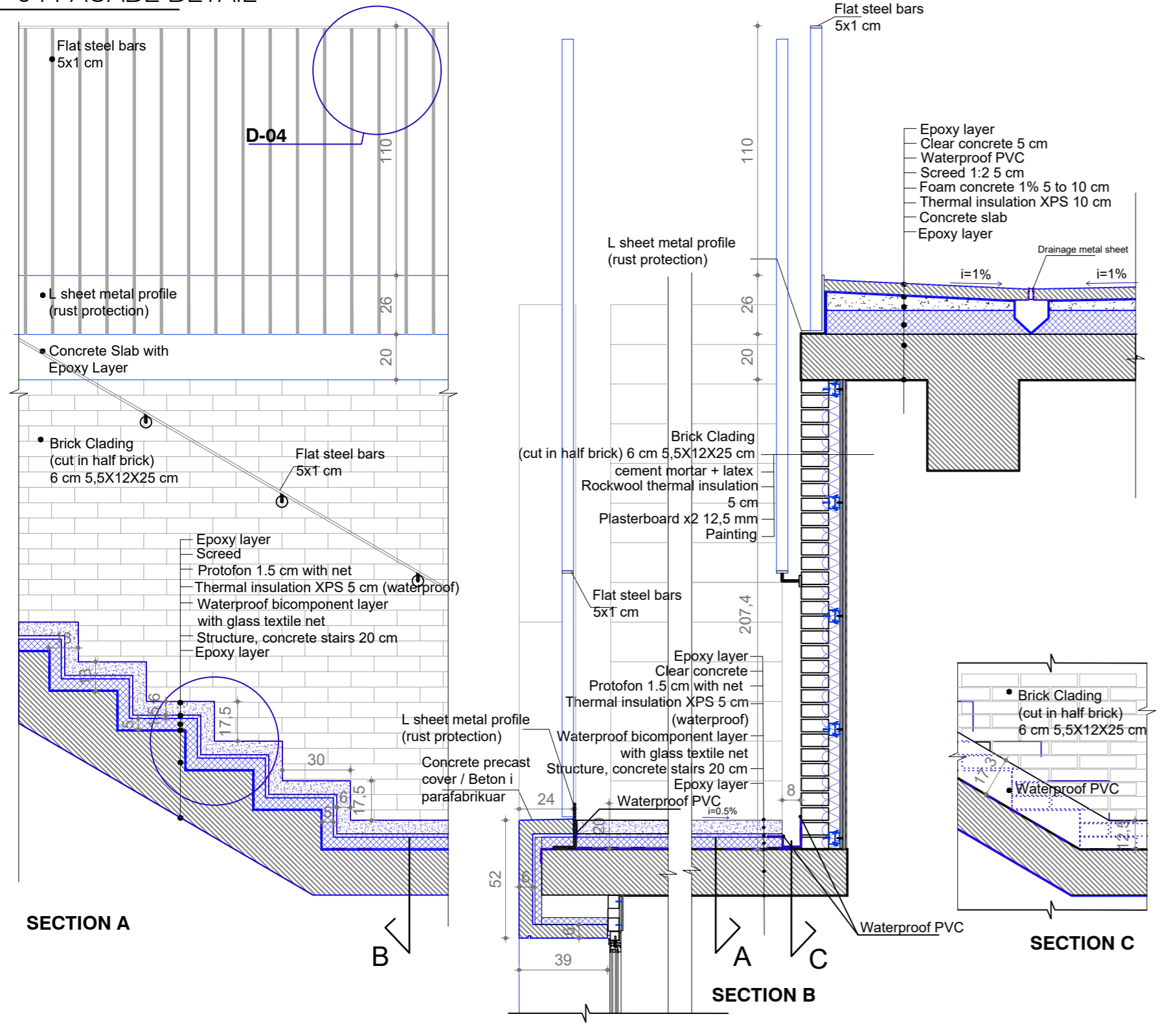

DF-05 FACADE DETAIL

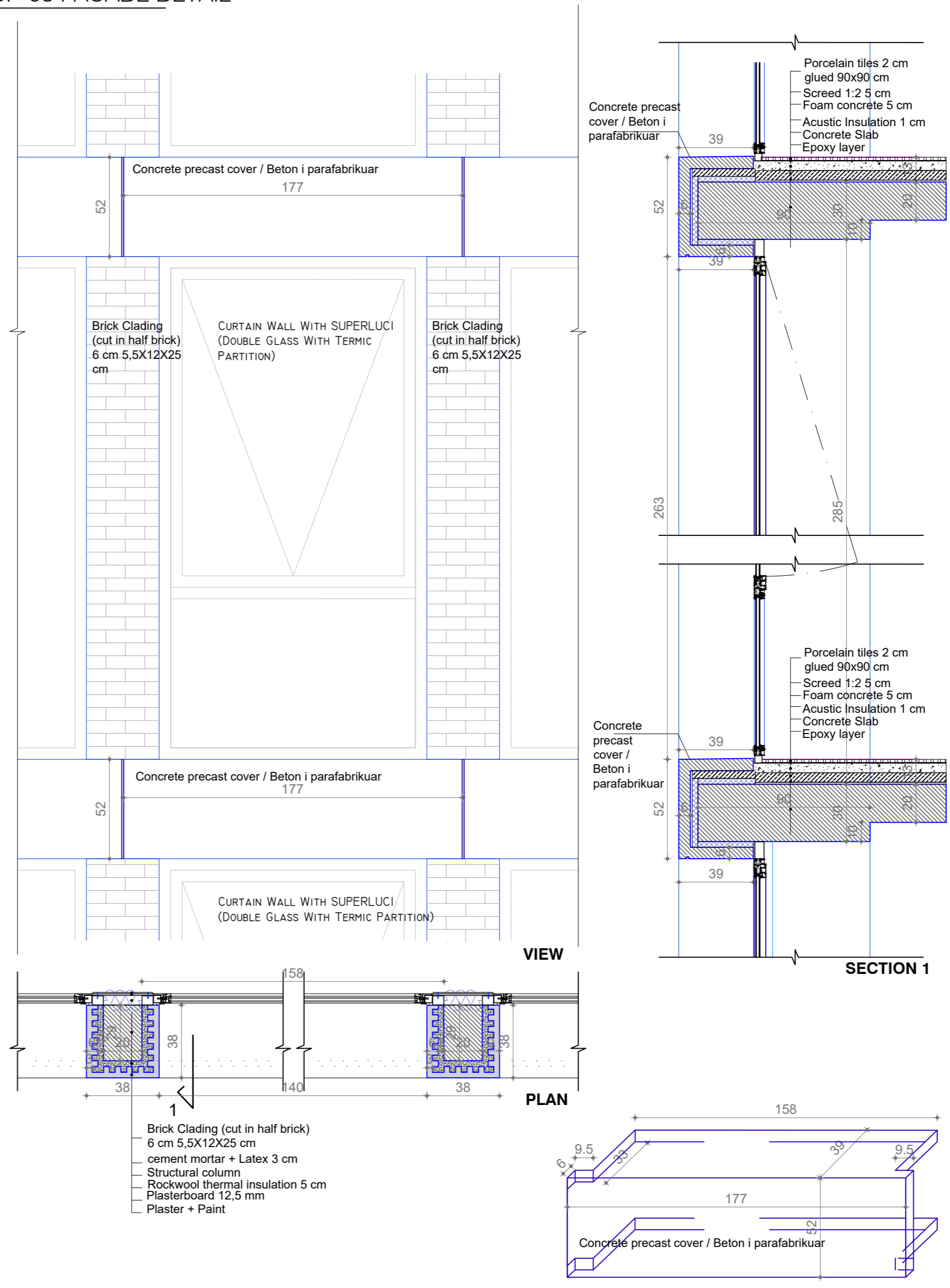

DF-01 FACADE DETAIL

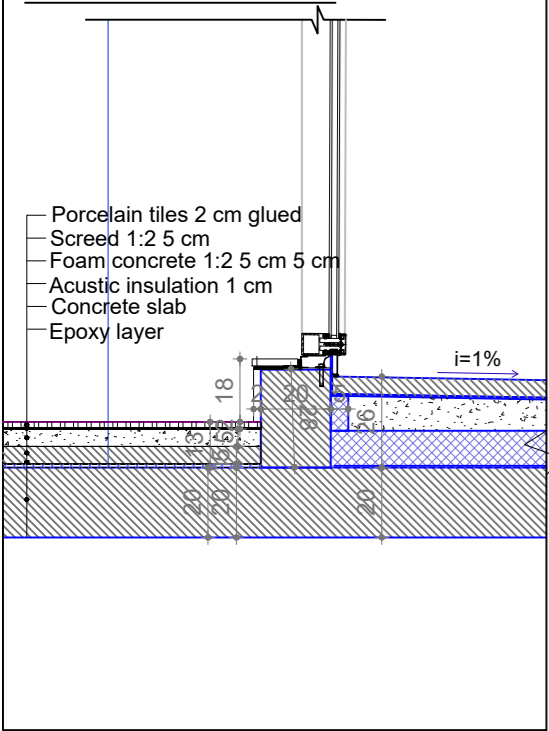

DF-02 DETAIL

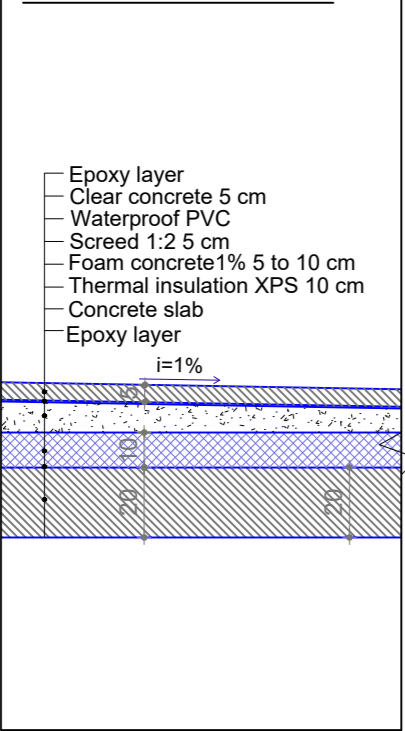

DF-03 FACADE DETAIL

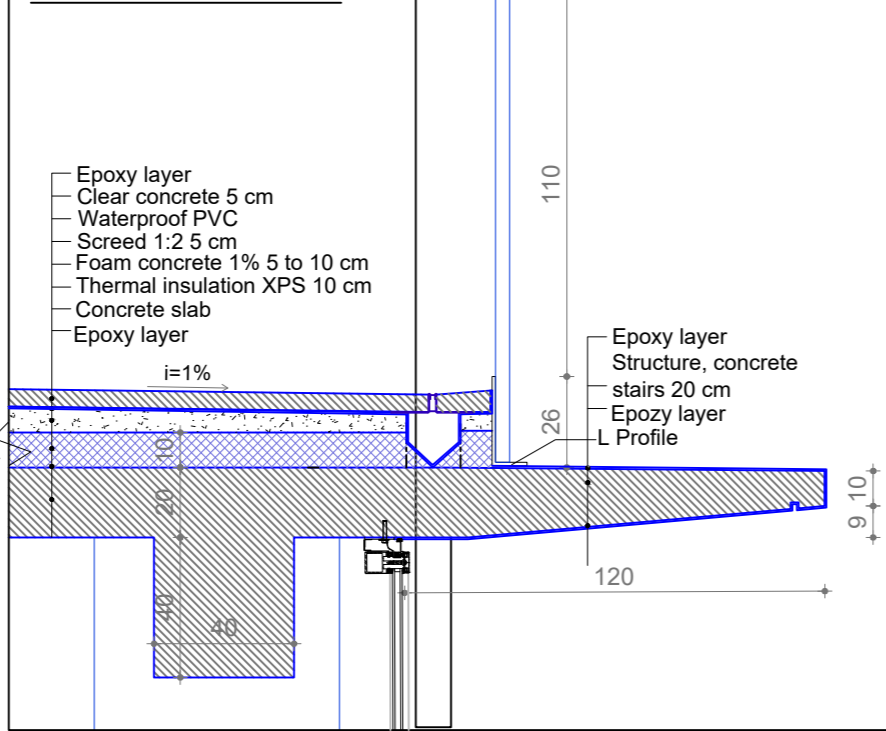

PROJEKTI / Project:
Ngritja e Infrastrukturës Arsimore të Liceut Franko-Shqiptar të Shkencave dhe Inovacionit, Bashkia Korçë / Establishment of the Educational Infrastructure of the Franco-Albanian Lyceum of Sciences and Innovation, Municipality of Korça

Klienti: FONDI SHQIPTAR I ZHVILLIMIT
Client: ALBANIAN DEVELOPMENT FUND

iRI Local Architecture Office (LOC) Studio Lukaku Architecture (VENO) Gazet Digital	N.6844	Firma / Signature: Lexoj dhe aprovovj / I read and approve.
ARCHISPACE Local Architecture Office (LOC) Studio Lukaku Architecture (VENO) New Notes	N.6732/14	Firma / Signature: Lexoj dhe aprovovj / I read and approve.
SPHAERA Local Architecture Office (LOC) Studio Lukaku Architecture (VENO) Abit Types	N.4654/14	Firma / Signature: Lexoj dhe aprovovj / I read and approve.
LORENC BEGAJ AVE CONSULTING Consultor Shkencë Studio Korçë Ing. Arben Dervishi Ing. Enxhel Shkëmbi Ing. Mita Haxhiu	K.2138/2 N.5628/12	Firma / Signature: Lexoj dhe aprovovj / I read and approve.
BURHAN TURKESHI ERMIR GJOKA Mechanical Engineering Inshirë Haxhi-Mehmet dhe MZ	K.1873/4 M.1174/2	Firma / Signature: Lexoj dhe aprovovj / I read and approve.
BASHKIM SHAHINAJ BESART DALLIU Electrical Engineering Inshirë Haxhi-Mehmet dhe MZ	E.0185/6 E.1412/2	Firma / Signature: Lexoj dhe aprovovj / I read and approve.

ALL DIMENSIONS HAVE TO BE VERIFIED BY THE CONTRACTOR ON THE CONSTRUCTION SITE
SHËRBIMET: These drawings are property of iRI. Rrugë DERSHVIH HIMA, nr 8 kati i parë - 1001 TIRANA. Copy, multiplication or distribution in whole or in part of these plans or any part of it without written permission of iRI is prohibited.

TË GJITHA DIMENSIONET DUHET TË VERIFIKOHEN NGA KONTRAKTORI NË VËND
SHËRBIMET: Këto vizime janë pronë e iRI, Rrugë DERSHVIH HIMA, nr 8 kati i parë - 1001 TIRANË. Kopimi, shumëtimi apo shpërndarja e këtyre vizimeve (apo pjesëve të tyre) pa lejen me shkrim të iRI-së është e ndaluar.

Issuer A	plan number: A.00.3	TITULLI / Title: Facade details
Faza: LN	data: 2026	shkalla e vizatimit: 1:20
		formati: A0

D-01 BENCH DETAIL

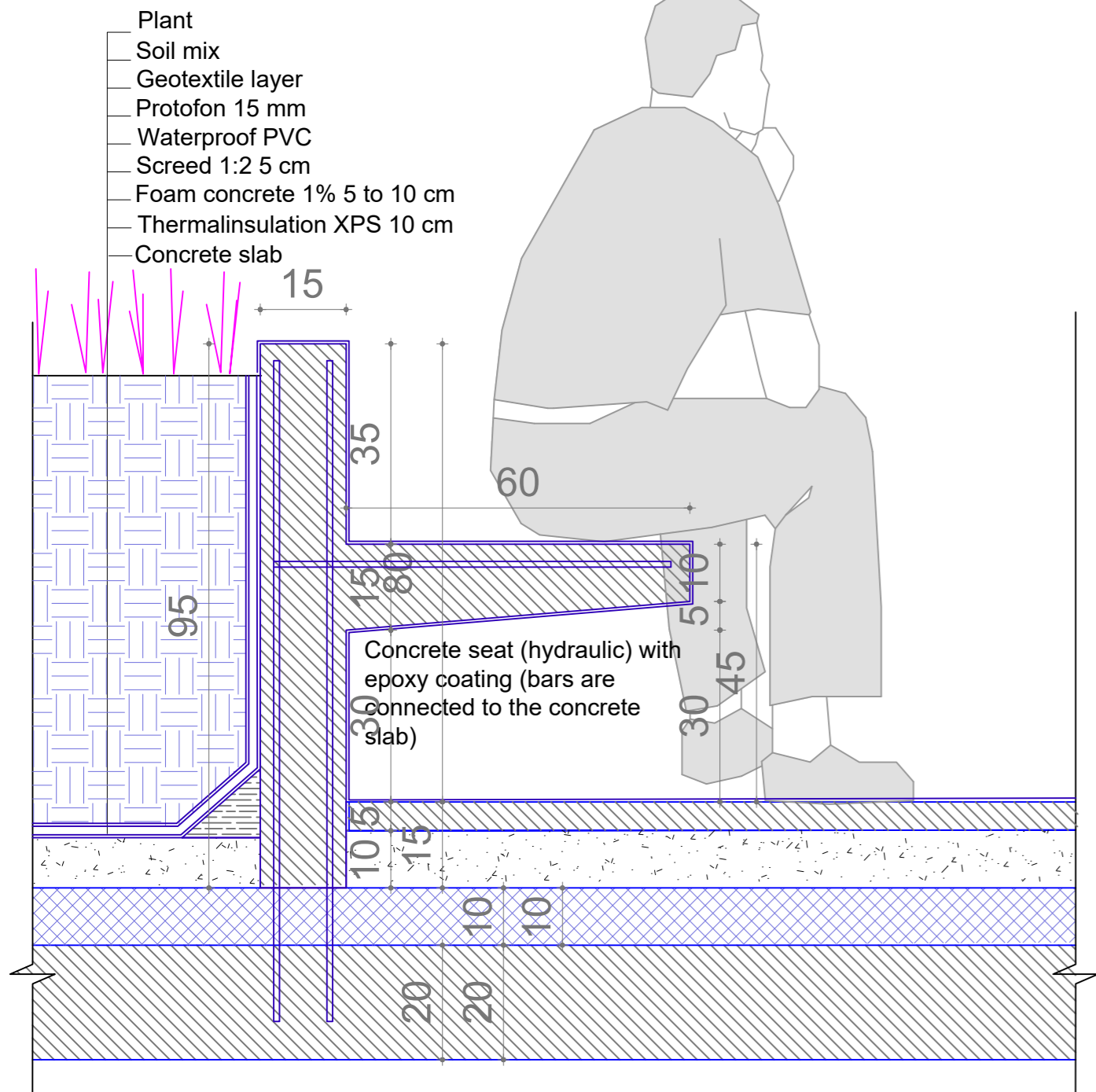

D-02 PARAPET DETAIL

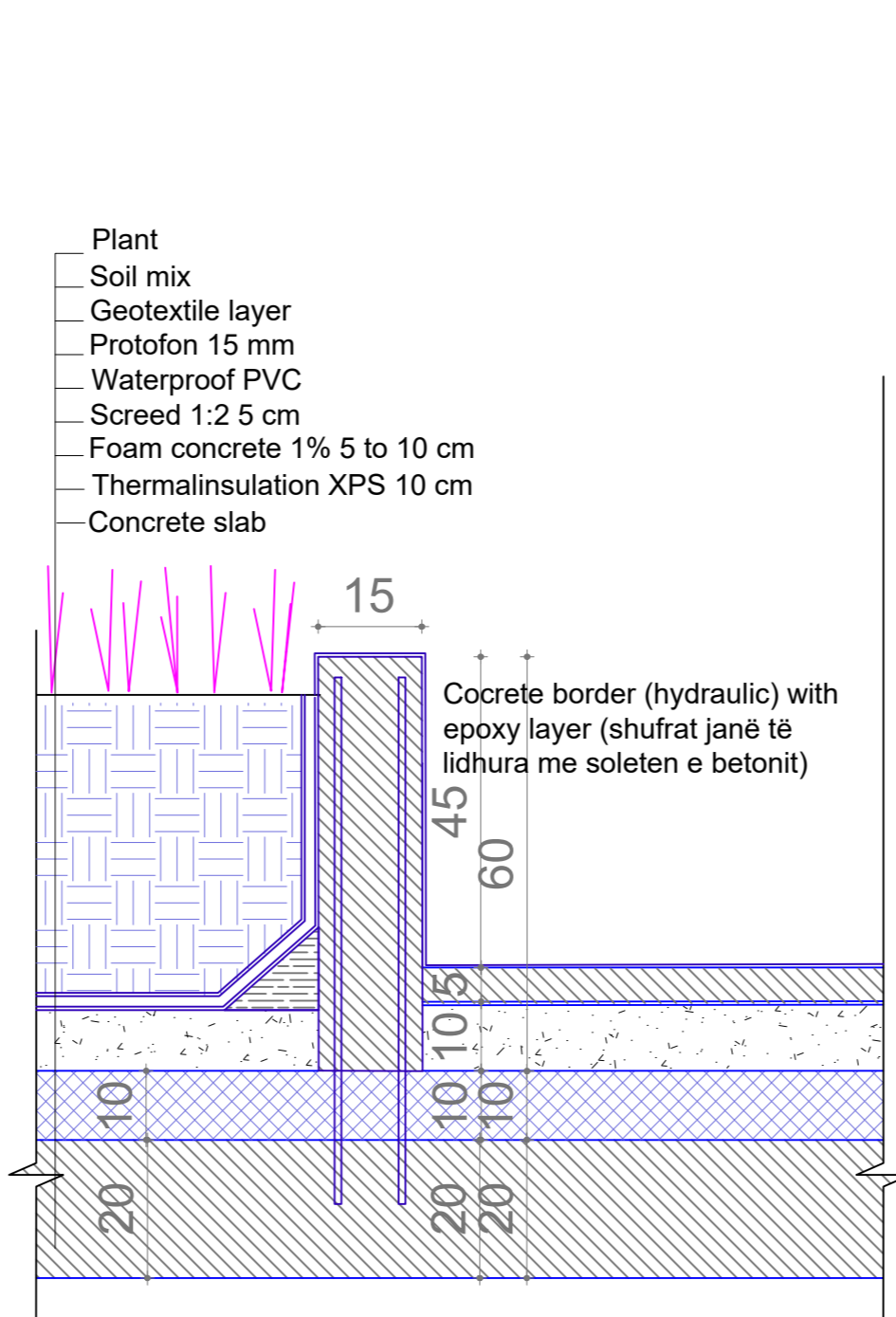

D-01a BENCH DETAIL (ALTERNATIVE)

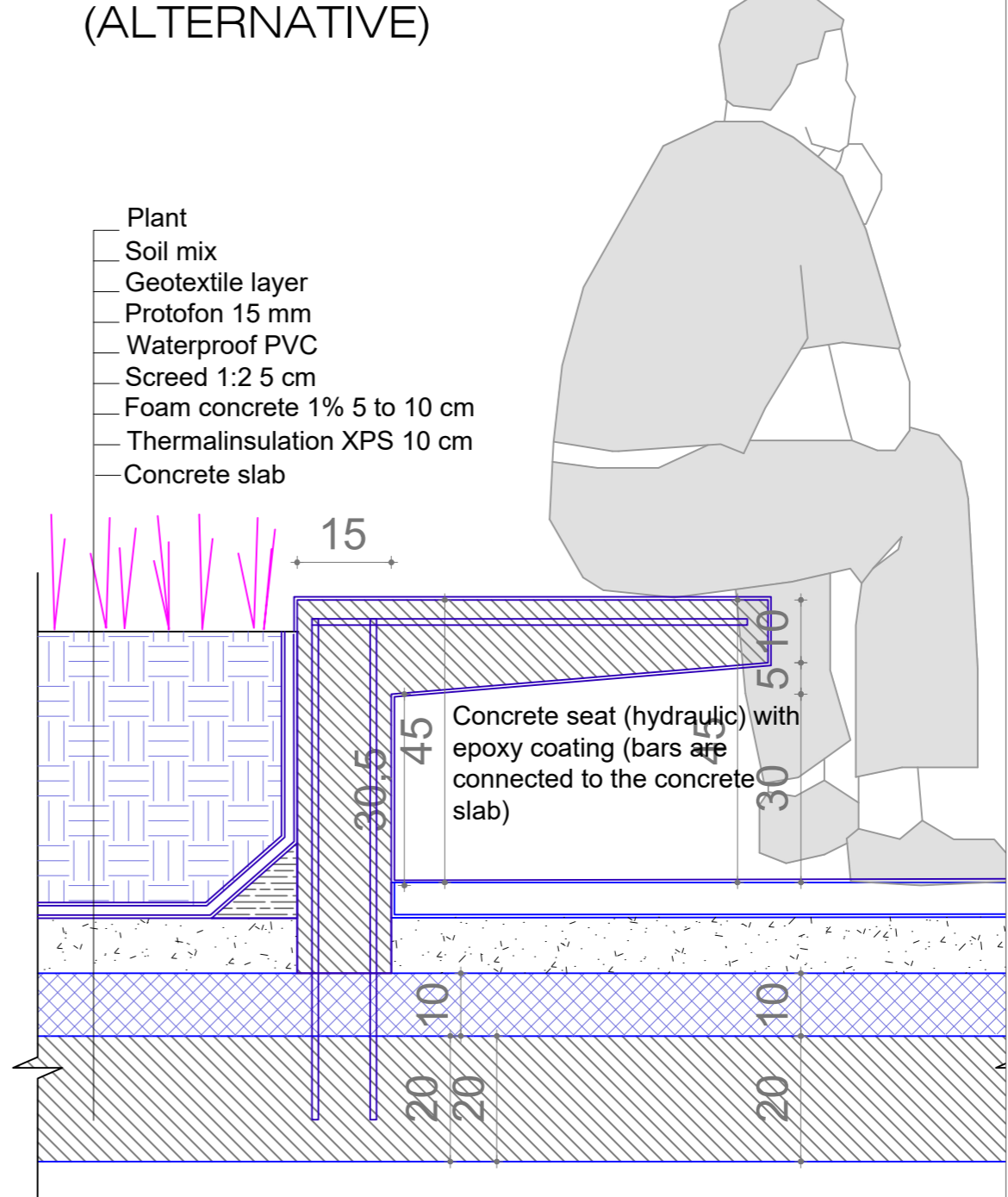

D-03 BALUSTRADE DETAIL

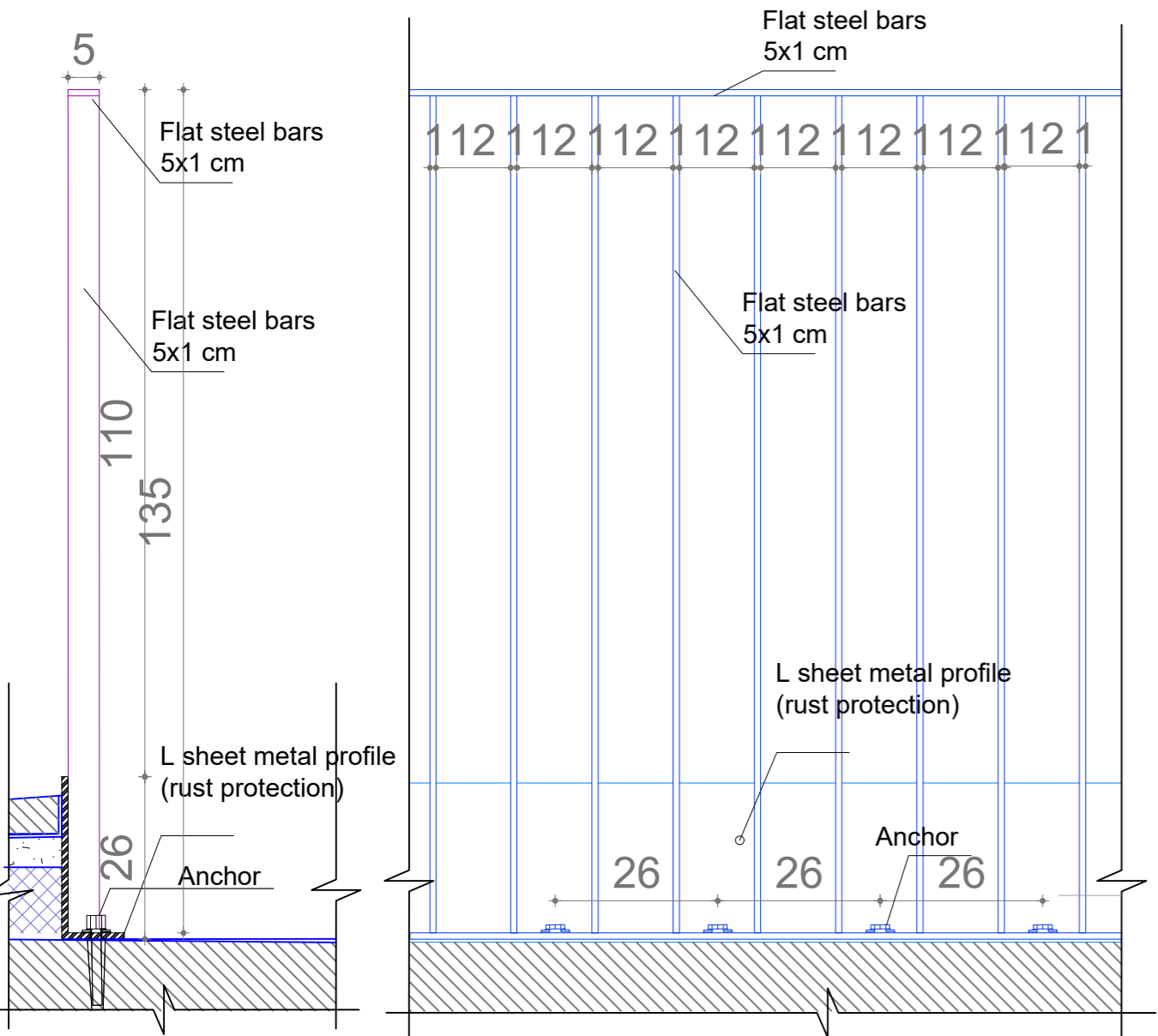

D-04 STAIR DETAIL

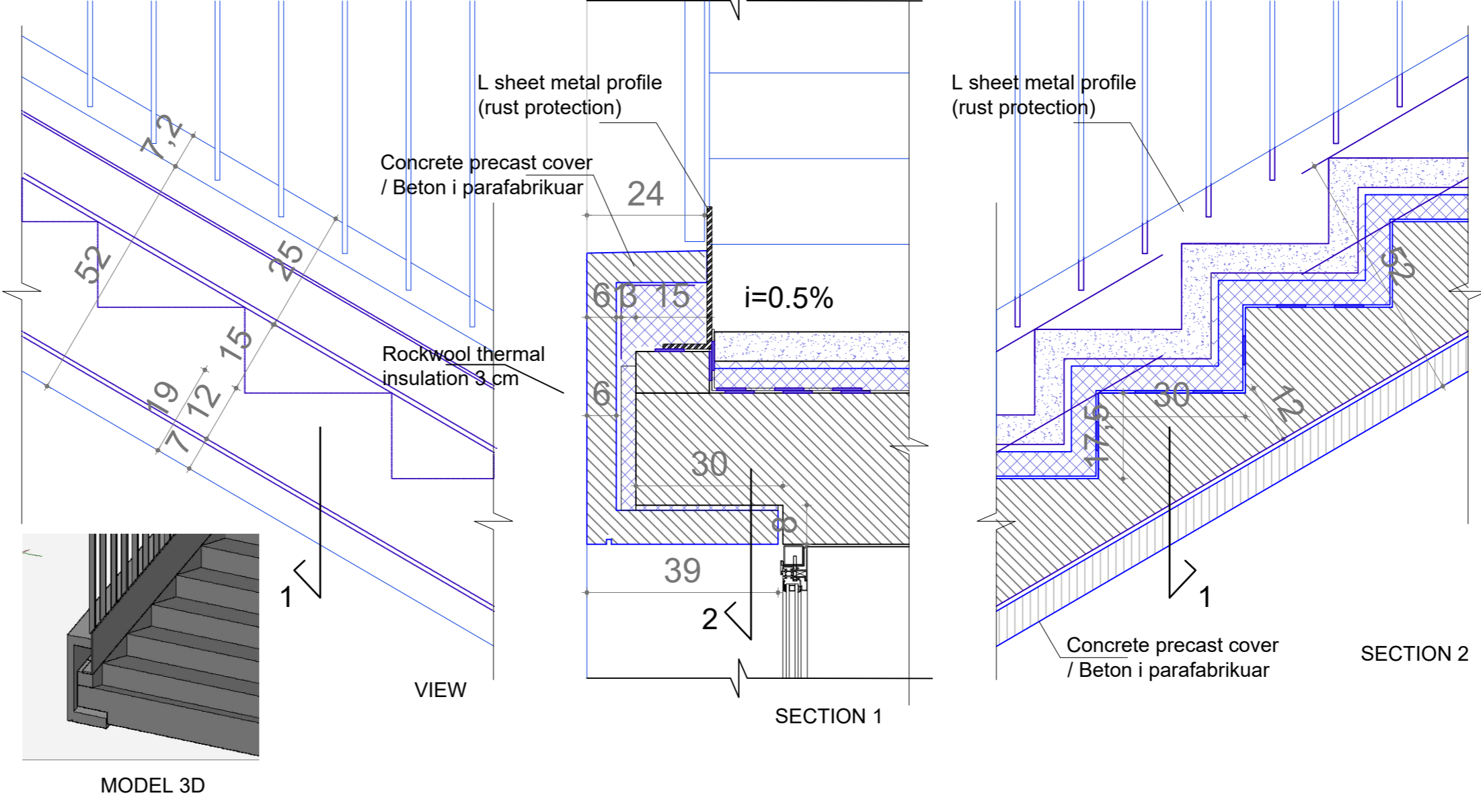

PROJEKTI / Project: Ngritja e Infrastrukturës Arsimore të Liceut Franko-Shqiptar të Shkencave dhe Inovacionit, Bashkia Korçë / Establishment of the Educational Infrastructure of the Franco-Albanian Lyceum of Sciences and Innovation, Municipality of Korça

Klienti: FONDI SHQIPTAR I ZHVILLIMIT
Client: ALBANIAN DEVELOPMENT FUND

iRI Local Architecture Office (L.O.C) Studio Lokale Arkitektura (VEND) Gazet Light	N.6844	Firma / Signature: Lexoj dhe aprovoj / I read and approve.
ARCHISPACE Local Architecture Office (L.O.C) Studio Lokale Arkitektura (VEND) Riza Topani	N.6732/14	Firma / Signature: Lexoj dhe aprovoj / I read and approve.
SPHAERA Local Architecture Office (L.O.C) Studio Lokale Arkitektura (VEND) Alban Topani	N.4654/14	Firma / Signature: Lexoj dhe aprovoj / I read and approve.
LORENC BEGAJ AVE CONSULTING Consultor Shkencë dhe Konstruksion (Ing. Arben Derishi) Ing. Enxhel Shalizi Ing. Mita Ruzhici	K.2138/2 N.5628/12	Firma / Signature: Lexoj dhe aprovoj / I read and approve.
BURHAN TURKESHI ERMIR GJOKA Mechanical Engineering Inzhineri Haki-Mehmet dhe MZ	K.1873/4 M.1174/2	Firma / Signature: Lexoj dhe aprovoj / I read and approve.
BASHKIM SHAHINAJ BESART DALLIU Electrical Engineering Inzhineri Eldon	E.0185/6 E.1412/2	Firma / Signature: Lexoj dhe aprovoj / I read and approve.

ALL DIMENSIONS HAVE TO BE VERIFIED BY THE CONTRACTOR ON THE CONSTRUCTION SITE.
SHËRBUESIT: Të gjitha dimensionet duhet të verifikohen nga kontraktori në vend.
IMPORTANT: These drawings are property of IRI. Rruga DERVISH HIMA, nr 8 kati i parë - 1001 TIRANA. Copy, multiplication or distribution in whole or in part of these plans (or any part of it) without written permission of IRI is prohibited.
TE GJITHA DIMENSIONET DUHET TË VERIFIKOHEN NGA KONTRAKTORI NË VEND.
E RËNDËSISHME: Këto vizatime janë pronë e IRI. Rruga DERVISH HIMA, nr 8 kati i parë - 1001 TIRANË. Kopimi, shumëlirimi apo shpërndarja e këtyre vizatimeve (apo pjesëve të tyre) pa lejen me shkrim të IRI-së është e ndaluar.

Issuer A	plan number: A.00.3	TITULLI / Title: Stairs details
Faza: LN	data: 2026	shkalla e vizatimit: 1:20
		formati: A0

T-03 CEILING DETAIL IN THE CANTEN AREA

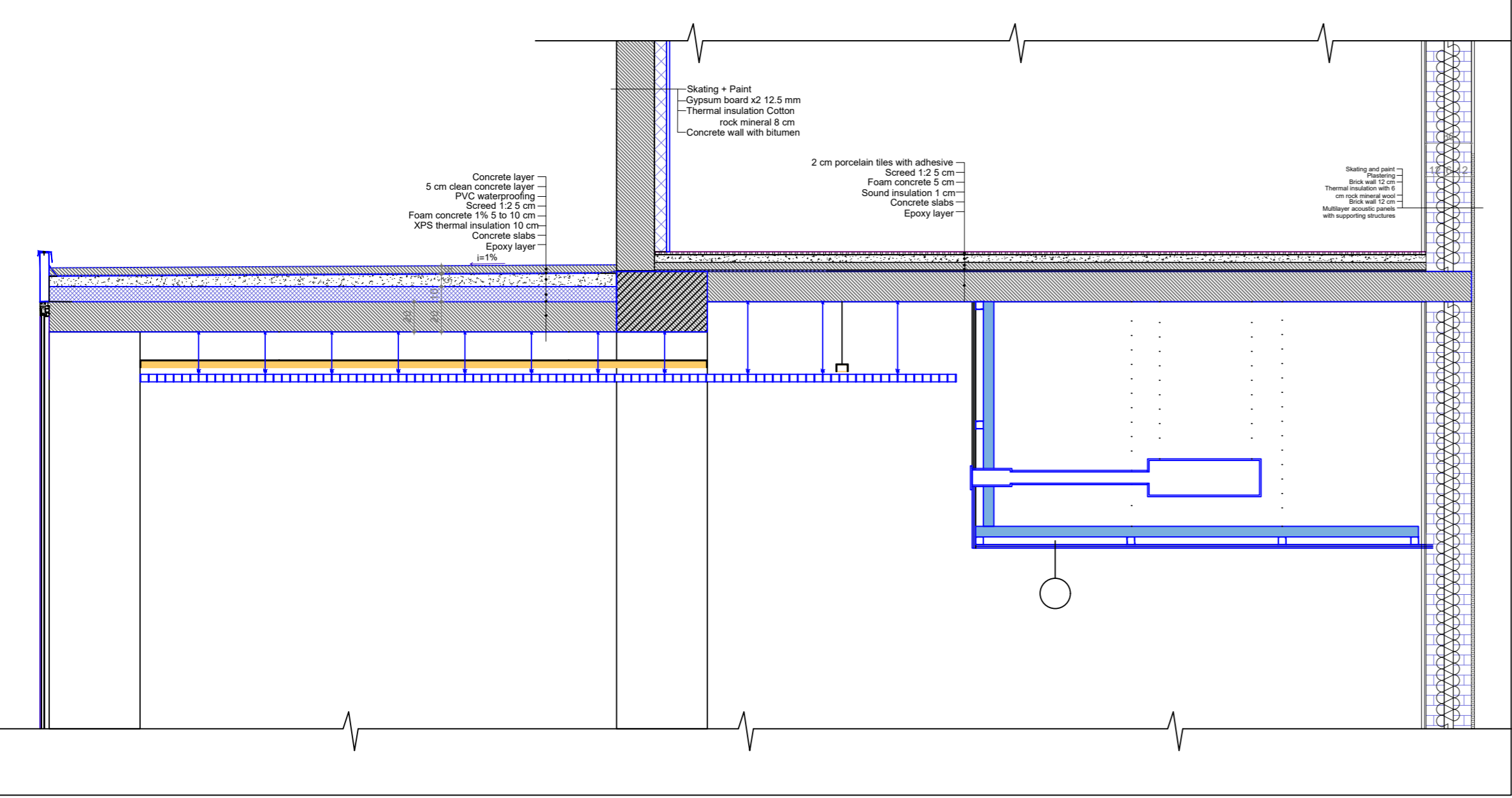

T-01 SUSPENDED MESH CEILING HALLWAY

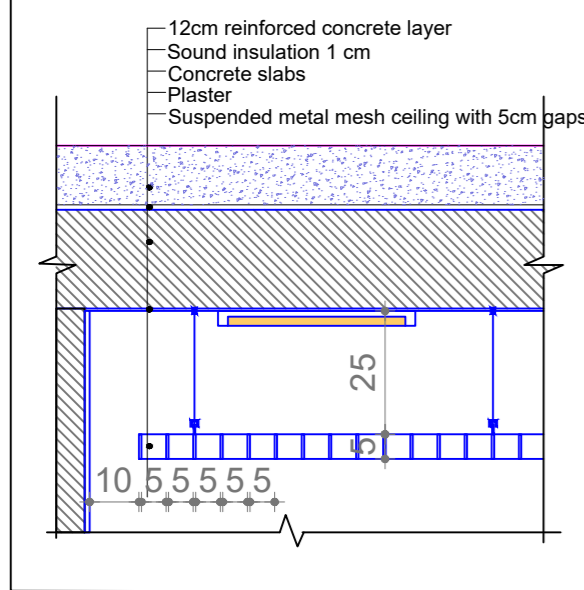

T-02 ACOUSTICAL CEILING-CLASS

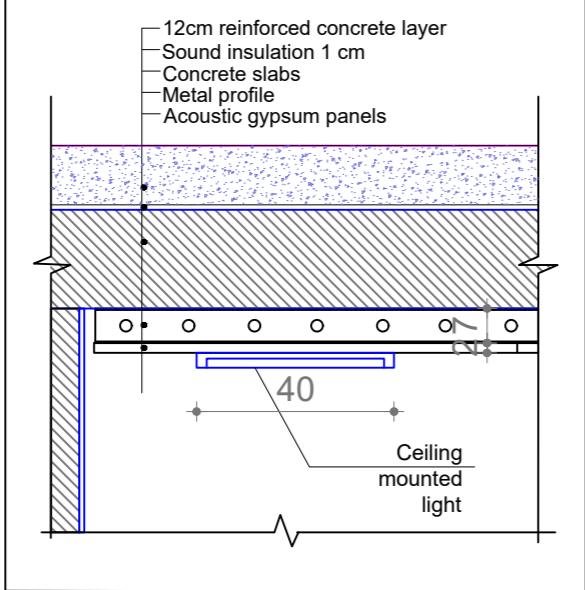

T-03 SUSPENDED CEILING-HALL

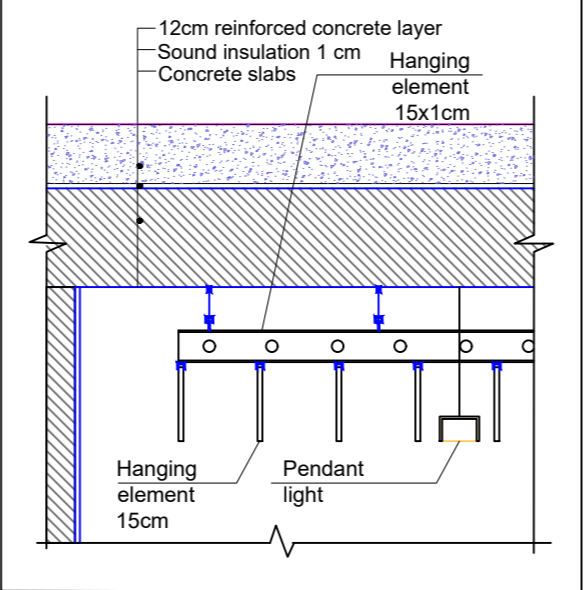

F-02B POLISHED CONCRETE ENTRANCE STAIRS

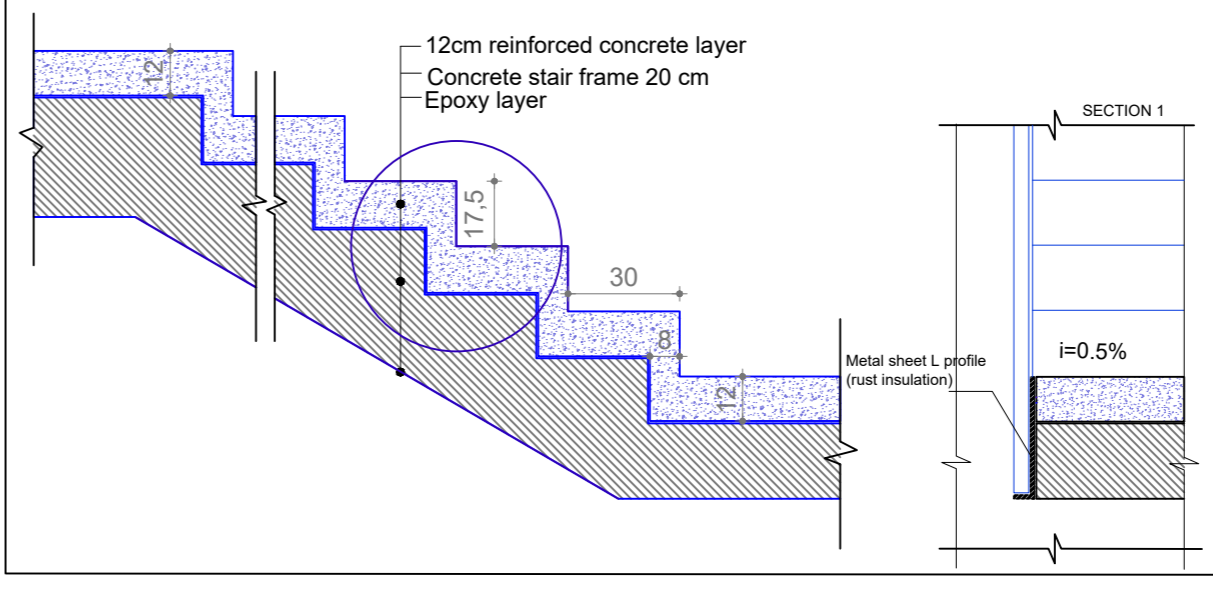

DF-06 FACADE DETAIL

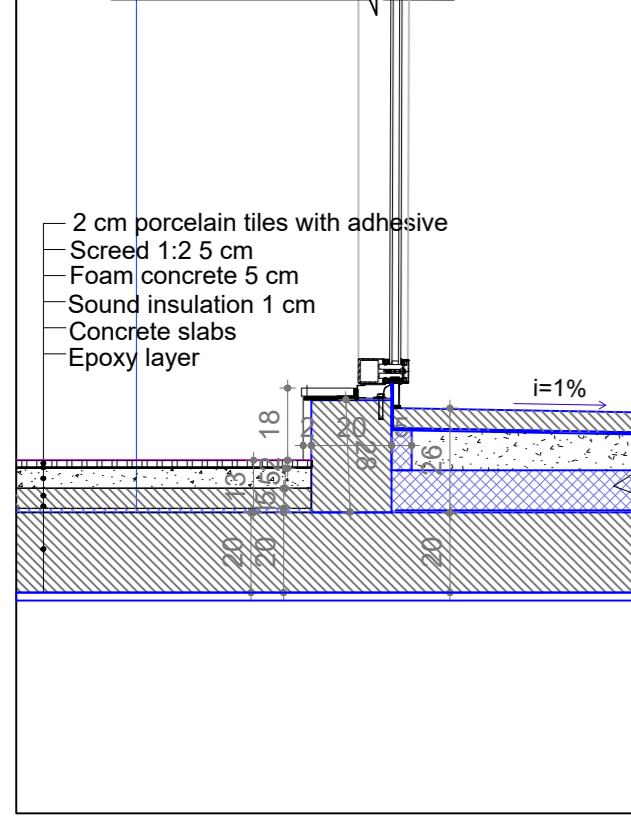

DF-07 FACADE DETAIL

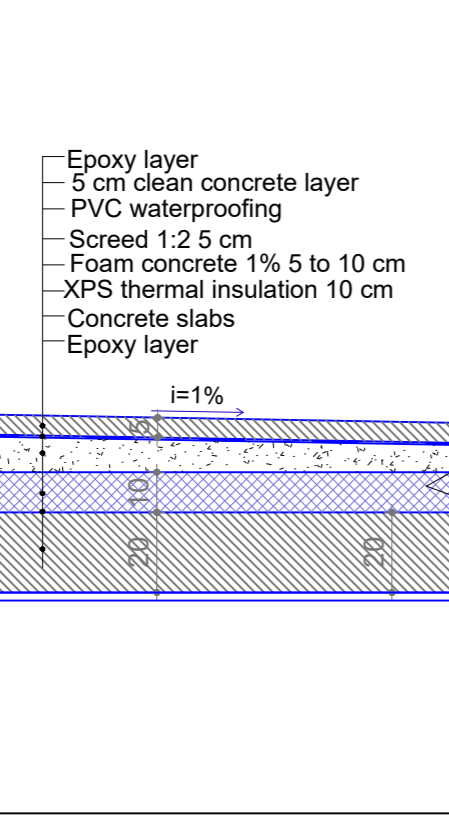

DF-08 FACADE DETAIL

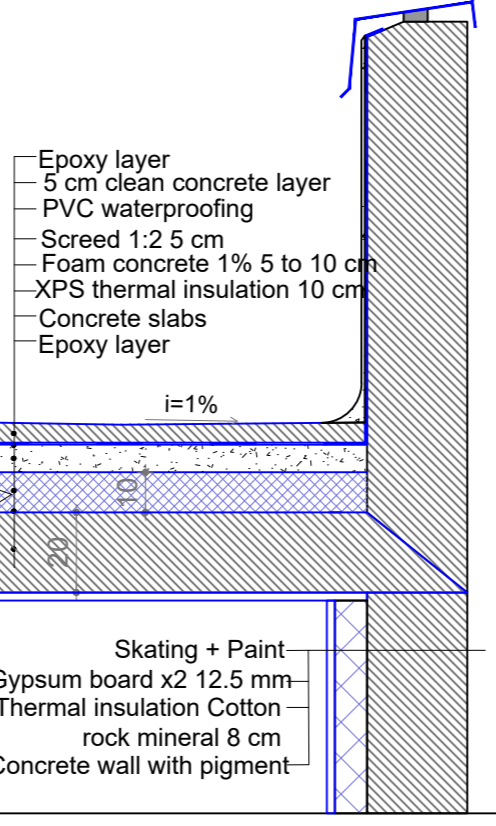

DF-07 FACADE DETAIL

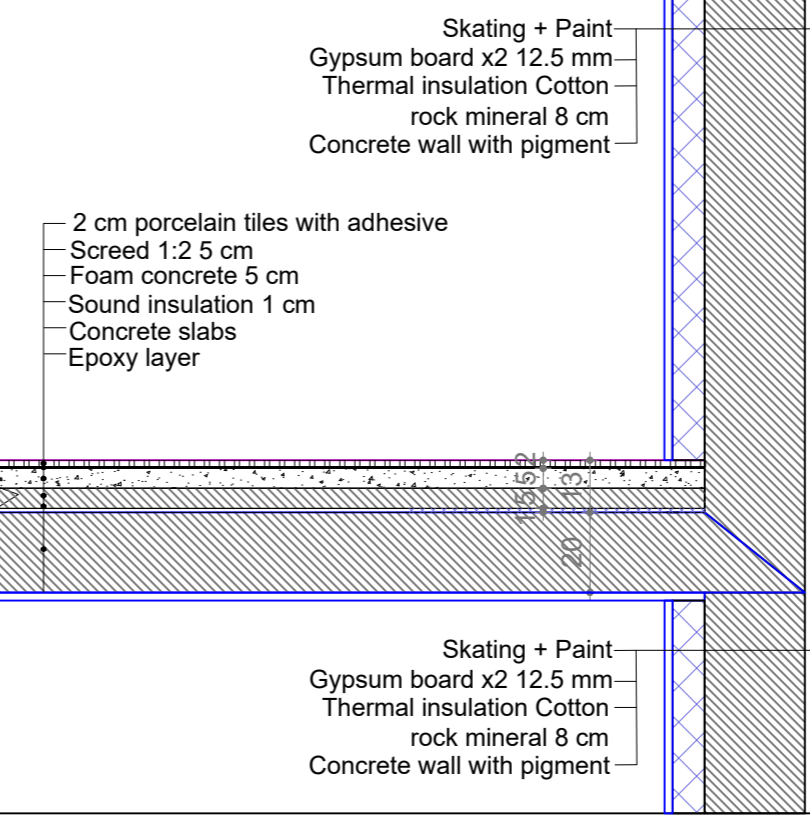

PROJEKTI / Project: Ngritja e Infrastrukturës Arsimore të Liceut Franko-Shqiptar të Shkencave dhe Inovacionit, Bashkia Korçë / Establishment of the Educational Infrastructure of the Franco-Albanian Lyceum of Sciences and Innovation, Municipality of Korça

Klienti: FONDI SHQIPTAR I ZHVILLIMIT
Client: ALBANIAN DEVELOPMENT FUND

iRI Local Architecture Office (LOCI) Studio Lokale Arkitekture (VENO) Gazet Ergjiri	N.6844	Firma / Signature: Lexoj dhe aprovoj / I read and approve.
ARCHISPACE Local Architecture Office (LOCI) Studio Lokale Arkitekture (VENO) Fishe Pritëse	N.6732/14	Firma / Signature: Lexoj dhe aprovoj / I read and approve.
SPHAERA Local Architecture Office (LOCI) Studio Lokale Arkitekture (VENO) Fishe Pritëse	N.4654/14	Firma / Signature: Lexoj dhe aprovoj / I read and approve.
LORENC BEGAJ AVE CONSULTING Consultor Shkollor Shkollor Konsulent Ing. Arben Derri Ing. Enxhel Shkollor Ing. Mirza Haxhiu	K.2138/2 N.5628/12	Firma / Signature: Lexoj dhe aprovoj / I read and approve.
BURHAN TURKESHI ERMIR GJOKA Mehnjehonjeshme Injeneri Injeneri Hani-Mehmeti dhe MZ	K.1873/4 M.1174/2	Firma / Signature: Lexoj dhe aprovoj / I read and approve.
BASHKIM SHAHINAJ BESART DALLIU Electrical Engineering Injeneri Elektrik	E.0185/6 E.1412/2	Firma / Signature: Lexoj dhe aprovoj / I read and approve.

DETAIL 1-CONNECTING NEW WALLS TO EXISTING WALLS

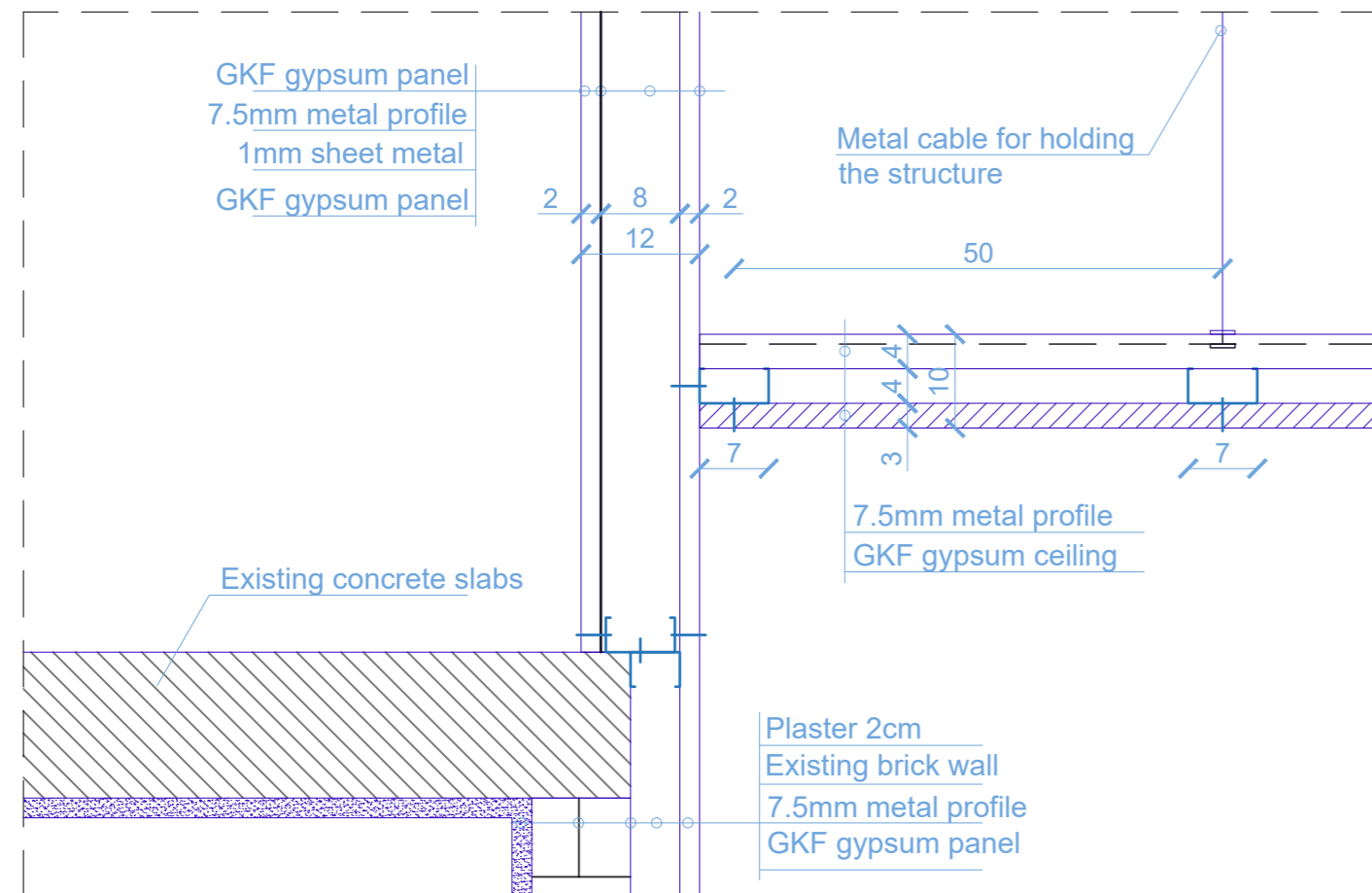

DETAIL 2-CONNECTING THE EXISTING CEILING TO THE NEW GYPSUM WALLS

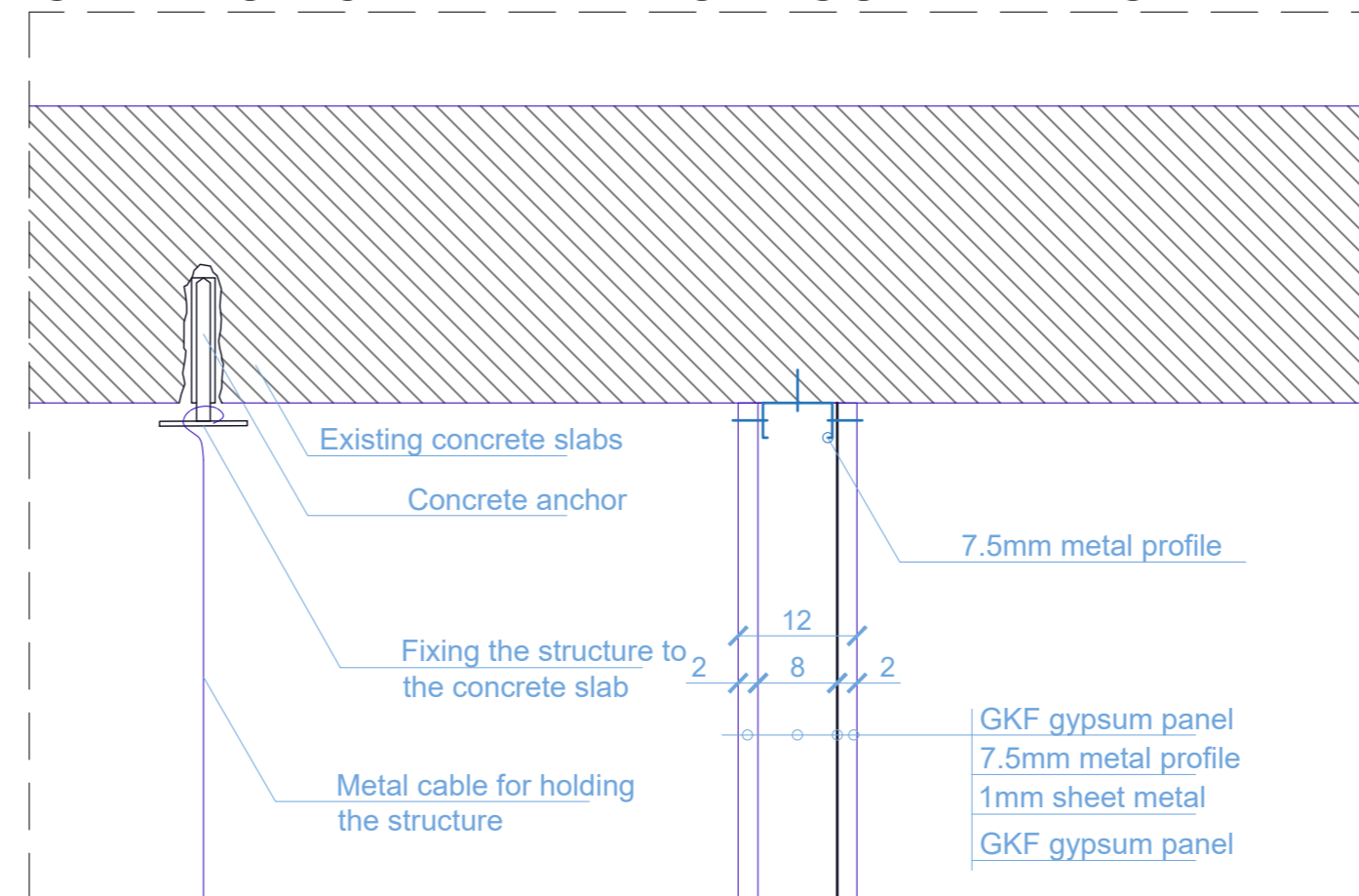

DETAIL 3-DETAIL OF TECHNOLOGICAL FLOOR

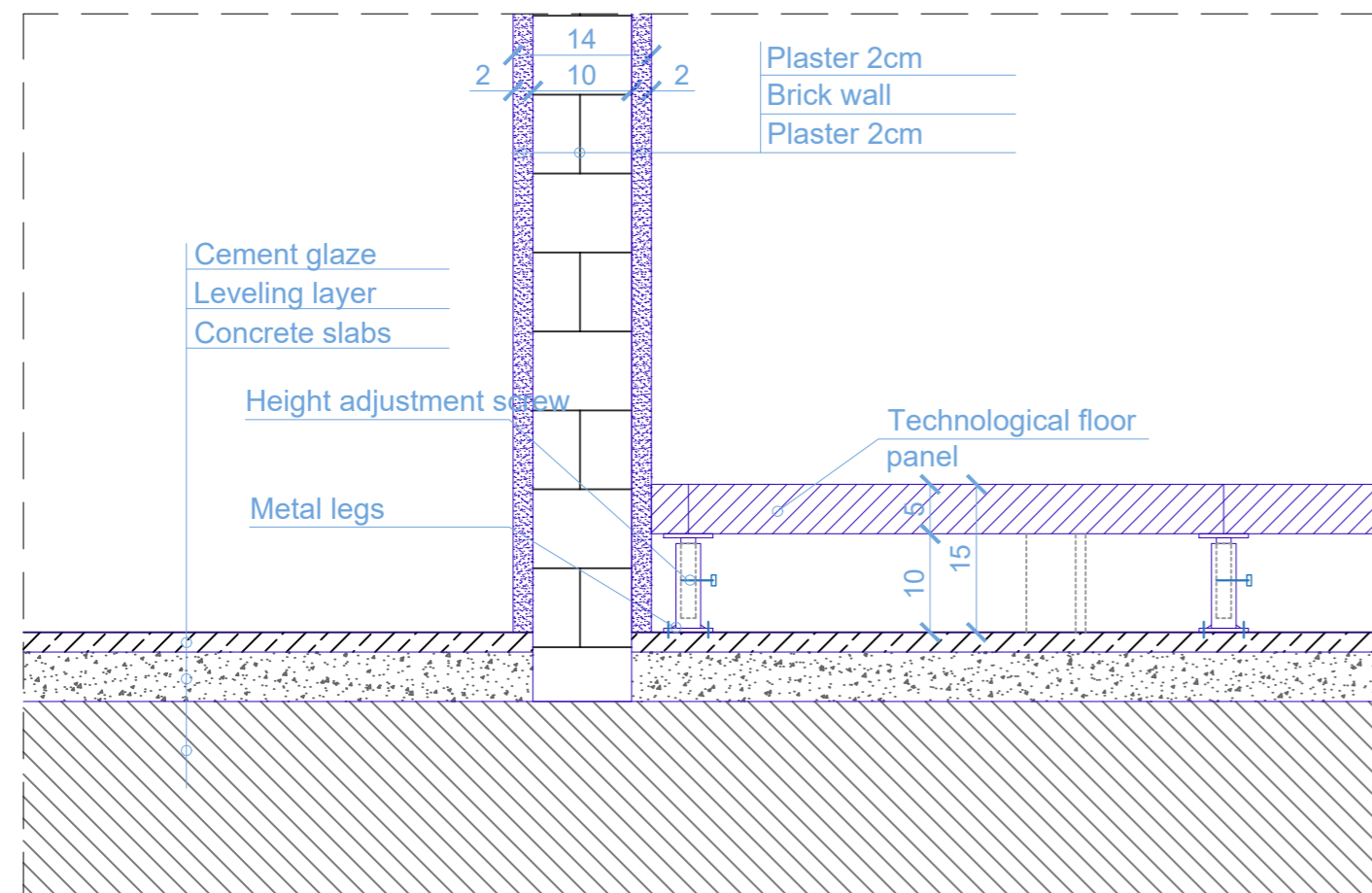

DETAIL 2-CONNECTING SUSPENDED CEILINGS TO NEW GYPSUM WALLS

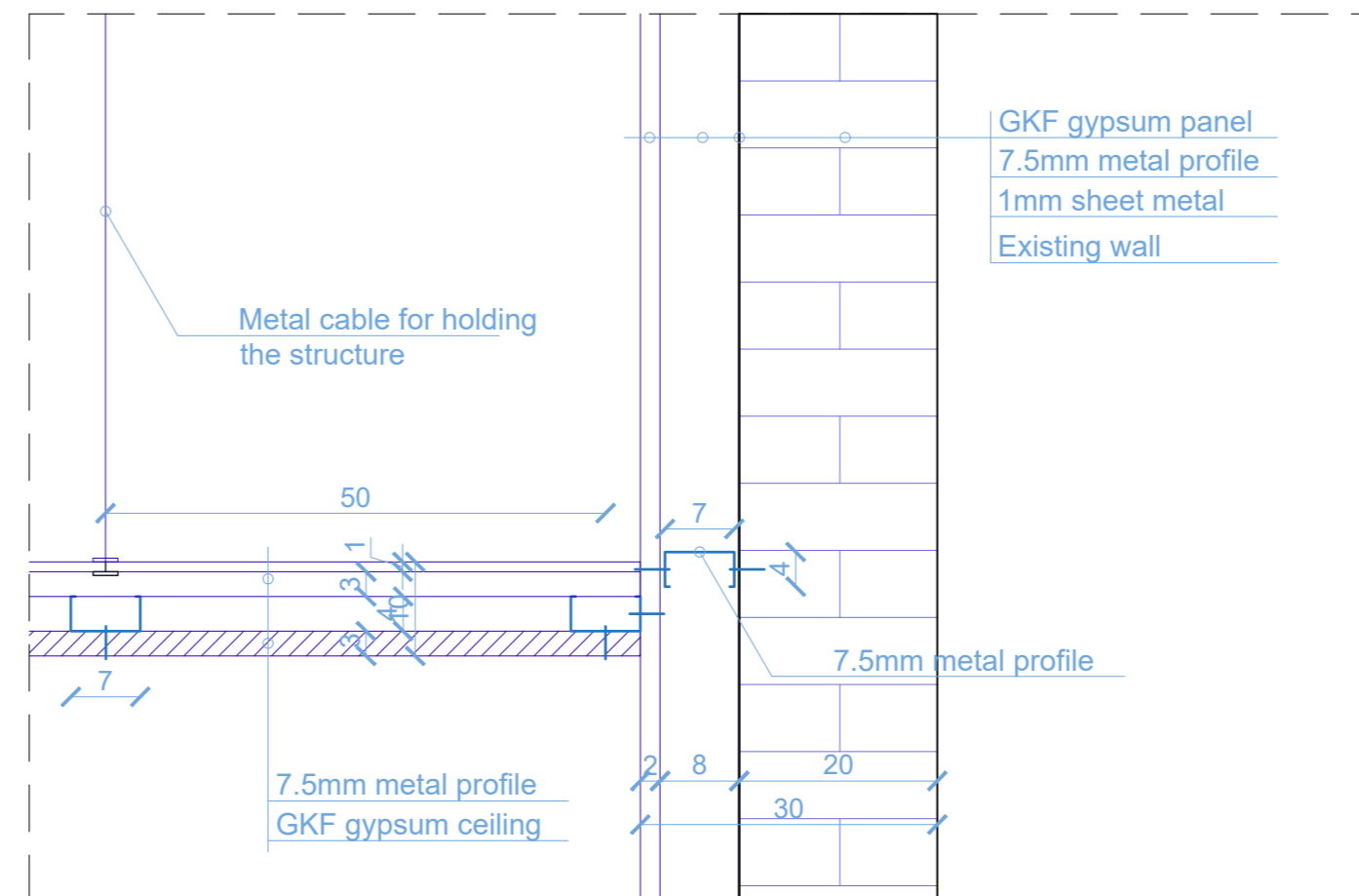

PROJEKTI / Project:
Ngritja e Infrastrukturës Arsimore të Liceut Franko-Shqiptar të Shkencave dhe Inovacionit, Bashkia Korçë / Establishment of the Educational Infrastructure of the Franco-Albanian Lyceum of Sciences and Innovation, Municipality of Korça

Klienti: FONDI SHQIPTAR I ZHVILLIMIT
Client: ALBANIAN DEVELOPMENT FUND

iRI Local Architecture Office Studio Lokale Arkitekture Gërdë Agaj	N.6844	Firma / Signature: Lexoj dhe aprovoj / I read and approve.
ARCHISPACE Local Architecture Office Studio Lokale Arkitekture Blau Nivica	N.6732/14	Firma / Signature: Lexoj dhe aprovoj / I read and approve.
SPHAERA Local Architecture Office Studio Lokale Arkitekture Blau Nivica	N.4654/14	Firma / Signature: Lexoj dhe aprovoj / I read and approve.
LORENC BEGAJ AVE CONSULTING Consultation Studio Studio Konsultime Ing. Arben Dervishi Rr. Zvezda Shqiptare Tirane, Shqipëri	K.2138/2 N.5628/12	Firma / Signature: Lexoj dhe aprovoj / I read and approve.
BURHAN TURKESHI ERIMIR GJOKA High-Mechanical Engineering Inzhineri Mekaniko-Masineri dhe MZ	K.1873/4 M.1174/2	Firma / Signature: Lexoj dhe aprovoj / I read and approve.
BASHKIM SHAHINAJ BESART DALLIU Electrical Engineering Inzhineri Elektrik	E.0185/6 E.1412/2	Firma / Signature: Lexoj dhe aprovoj / I read and approve.

ALL DIMENSIONS HAVE TO BE VERIFIED BY THE CONTRACTOR ON THE CONSTRUCTION SITE
IMPORTANT: These drawings are property of IRI. Rruga DERSVISH HIMA, nr 8 kati i pare - 1001 TIRANA. Copy, multiplication or distribution in/without parties of these plans (or any part of it) without written permission of IRI is prohibited.

TË QILTHA DIMENSIONET DUHET TË VERIFIKOHEN NGA KONTRAKTORI NË VEND
E RËNDËSISHME: Këto vizatime janë pronë e IRI. Rruga DERSVISH HIMA, nr 8 kati i parë - 1001 TIRANË. Kopjimi, shumëllojimi apo shpërndarja e këtyre vizatimeve (apo pjesëve të tyre) pa lejen me shkrim të IRI është e ndaluar.

issuer A	plan number: A.00.3	TITULLI / Title: Details of wall, ceiling and floor coverings of the server room, electrical cabinet
Faza: LN	data: 2026	shkalla e vizatimit: 1:20
		formati: A0

LEGJENDA/ Legenda:

SHËNIME/ Notes:

PROJEKTI / Project:
Ngritja e Infrastrukturës Arsimore të Liceut Franko-Shqiptar të Shkencave dhe Inovacionit, Bashkia Korçë / Establishment of the Educational Infrastructure of the Franco-Albanian Lyceum of Sciences and Innovation, Municipality of Korça

Klienti: FONDI SHQIPTAR I ZHVILLIMIT
Client: ALBANIAN DEVELOPMENT FUND

IRI

Local Architecture Office (LOC)
Studio Lokale Arkitekture (VEND)
Gent Agoll

N.6844

Firma / Signature:
Lexoj dhe aprovj / I read and approve.

ARCHISPACE

Local Architecture Office (LOC)
Studio Lokale Arkitekture (VEND)
Rais Petrela

N.6732/14

Firma / Signature:
Lexoj dhe aprovj / I read and approve.

SPHAERA

Local Architecture Office (LOC)
Studio Lokale Arkitekture (VEND)
Ajdil Topore

N.4654/14

Firma / Signature:
Lexoj dhe aprovj / I read and approve.

**LORENC BEGAJ
AVE CONSULTING**

Construction Studio
Studio Konstruksioni
ing. Arben Dervishaj
ing. Ermal Spahiu
ing. Ina Hoxhaj

K.2138/2
N.5628/12

Firma / Signature:
Lexoj dhe aprovj / I read and approve.

**BURHAN TURKESHI
ERMIR GJOKA**

Hydro-Mechanical Engineering
Inzhinieri Hidro-Mekanik dhe MNZ

K.1873/4
M.1174/2

Firma / Signature:
Lexoj dhe aprovj / I read and approve.

**BASHKIM SHAHINAJ
BESART DALLIU**

Electrical Engineering
Inzhinieri Elektrik

E.0185/6
E.1412/2

Firma / Signature:
Lexoj dhe aprovj / I read and approve.

ALL DIMENSIONS HAVE TO BE VERIFIED BY THE CONTRACTOR ON THE CONSTRUCTION SITE
IMPORTANT: These drawings are property of IRI. Rruga DERSH HIMA, nr 8 kati i pare - 1001 TIRANA. Copy, multiplication or distribution inbetween parties of these plans (or any part of it) without written permission of IRI is prohibited.

TË GJITHA DIMENSIONET DUHET TË VERIFIKOHEN NGA KONTRAKTORI NË VEND
E RËNDËSISHME: Këto vizatime janë pronë e IRI, Rruga DERSH HIMA, nr 8 kati i parë - 1001 TIRANË. Kopjimi, shumfishimi apo shpërndarja e këtyre vizatimeve (apo pjesëve të tyre) pa lejen me shkrim të IRI është e ndaluar.

issuer A	plan number: A.00.1	TITULLI / Title: Render Konvikti	
Faza: LN	data: 2026	shkalla e vizatimit: 1:200	formati: A3

N



LEGJENDA/ Legenda:

SHENIME/ Notes:

PROJEKTI / Project:
Ngritja e Infrastrukturës Arsimore të Liceut Franko-Shqiptar të Shkencave dhe Inovacionit, Bashkia Korçë / Establishment of the Educational Infrastructure of the Franco-Albanian Lyceum of Sciences and Innovation, Municipality of Korça

Klienti: FONDI SHQIPTAR I ZHVILLIMIT
Client: ALBANIAN DEVELOPMENT FUND

IRI

Local Architecture Office (LOC)
Studio Lokale Arkitekture (VEND)
Gent Agoll

N.6844

Firma / Signature:
Lexoj dhe aprovoj / I read and approve.

ARCHISPACE

Local Architecture Office (LOC)
Studio Lokale Arkitekture (VEND)
Rais Petrela

N.6732/14

Firma / Signature:
Lexoj dhe aprovoj / I read and approve.

SPHAERA

Local Architecture Office (LOC)
Studio Lokale Arkitekture (VEND)
Akid Topore

N.4654/14

Firma / Signature:
Lexoj dhe aprovoj / I read and approve.

**LORENC BEGAJ
AVE CONSULTING**

Construction Studio
Studio Konstruksioni
ing. Arben Dervishaj
ing. Ermal Spahiu
ing. Ina Hoxhaj

K.2138/2
N.5628/12

Firma / Signature:
Lexoj dhe aprovoj / I read and approve.

**BURHAN TURKESHI
ERMIR GJOKA**

Hydro-Mechanical Engineering
Inzhinieri Hidro-Mekanik dhe MNZ

K.1873/4
M.1174/2

Firma / Signature:
Lexoj dhe aprovoj / I read and approve.

**BASHKIM SHAHINAJ
BESART DALLIU**

Electrical Engineering
Inzhinieri Elektrik

E.0185/6
E.1412/2

Firma / Signature:
Lexoj dhe aprovoj / I read and approve.

ALL DIMENSIONS HAVE TO BE VERIFIED BY THE CONTRACTOR ON THE CONSTRUCTION SITE
IMPORTANT: These drawings are property of IRI. Rruga DERSH HIMA, nr 8 kati i pare - 1001 TIRANA. Copy, multiplication or distribution inbetween parties of these plans (or any part of it) without written permission of IRI is prohibited.

TË GJITHA DIMENSIONET DUHET TË VERIFIKOHEN NGA KONTRAKTORI NË VËND
E RËNDËSISHME: Këto vizatime janë pronë e IRI. Rruga DERSH HIMA, nr 8 kati i parë - 1001 TIRANË. Kopjimi, shumfishimi apo shpërndarja e këtyre vizatimeve (apo pjesëve të tyre) pa lejen me shkrim të IRI është e ndaluar.

issuer A	plan number: A.00.1	TITULLI / Title: Render _ Konvikti	
Faza: LN	data: 2026	shkalla e vizatimit: 1:200	formati: A3



LEGJENDA/ Legenda:

SHËNIME/ Notes:

PROJEKTI / Project:
Ngritja e Infrastrukturës Arsimore të Liceut Franko-Shqiptar të Shkencave dhe Inovacionit, Bashkia Korçë / Establishment of the Educational Infrastructure of the Franco-Albanian Lyceum of Sciences and Innovation, Municipality of Korça

Klienti: FONDI SHQIPTAR I ZHVILLIMIT
Client: ALBANIAN DEVELOPMENT FUND

IRI

Local Architecture Office (LOC)
Studio Lokale Arkitekture (VEND)
Gent Agoll

N.6844

Firma / Signature:
Lexoj dhe aprovj / I read and approve.

ARCHISPACE

Local Architecture Office (LOC)
Studio Lokale Arkitekture (VEND)
Rais Petrela

N.6732/14

Firma / Signature:
Lexoj dhe aprovj / I read and approve.

SPHAERA

Local Architecture Office (LOC)
Studio Lokale Arkitekture (VEND)
Aldid Topore

N.4654/14

Firma / Signature:
Lexoj dhe aprovj / I read and approve.

**LORENC BEGAJ
AVE CONSULTING**

Construction Studio
Studio Konstruksioni
ing. Arben Dervishi
ing. Ermal Spahiu
ing. Ina Hotaj

K.2138/2
N.5628/12

Firma / Signature:
Lexoj dhe aprovj / I read and approve.

**BURHAN TURKESHI
ERMIR GJOKA**

Hydro-Mechanical Engineering
Inzhinieri Hidro-Mekanik dhe MNZ

K.1873/4
M.1174/2

Firma / Signature:
Lexoj dhe aprovj / I read and approve.

**BASHKIM SHAHINAJ
BESART DALLIU**

Electrical Engineering
Inzhinieri Elektrik

E.0185/6
E.1412/2

Firma / Signature:
Lexoj dhe aprovj / I read and approve.

ALL DIMENSIONS HAVE TO BE VERIFIED BY THE CONTRACTOR ON THE CONSTRUCTION SITE
IMPORTANT: These drawings are property of IRI. Rruga DERSH HIMA, nr 8 kati i pare - 1001 TIRANA. Copy, multiplication or distribution inbetween parties of these plans (or any part of it) without written permission of IRI is prohibited.

TË GJITHA DIMENSIONET DUHET TË VERIFIKOHEN NGA KONTRAKTORI NË VEND
E RËNDËSISHME: Këto vizatime janë pronë e IRI. Rruga DERSH HIMA, nr 8 kati i parë - 1001 TIRANË. Kopjimi, shumëfishimi apo shpërndarja e këtyre vizatimeve (apo pjesëve të tyre) pa lejen me shkrim të IRI është e ndaluar.

issuer	plan number:	TITULLI / Title:
A	A.00.1	Render Konvikti

Faza:	data:	shkalla e vizatimit:	formati:
LN	2026	1:200	A3



LEGJENDA/ Legenda:

SHËNIME/ Notes:

PROJEKTI / Project:
Ngritja e Infrastrukturës Arsimore të Liceut Franko-Shqiptar të Shkencave dhe Inovacionit, Bashkia Korçë / Establishment of the Educational Infrastructure of the Franco-Albanian Lyceum of Sciences and Innovation, Municipality of Korça

Klienti: FONDI SHQIPTAR I ZHVILLIMIT
Client: ALBANIAN DEVELOPMENT FUND

IRI

Local Architecture Office (LOC)
Studio Lokale Arkitekture (VEND)
Gent Agoli

N.6844

Firma / Signature:
Lexoj dhe aprovoj / I read and approve.

ARCHISPACE

Local Architecture Office (LOC)
Studio Lokale Arkitekture (VEND)
Rasa Petrela

N.6732/14

Firma / Signature:
Lexoj dhe aprovoj / I read and approve.

SPHAERA

Local Architecture Office (LOC)
Studio Lokale Arkitekture (VEND)
Aklid Topore

N.4654/14

Firma / Signature:
Lexoj dhe aprovoj / I read and approve.

**LORENC BEGAJ
AVE CONSULTING**

Construction Studio
Studio Konstruksioni
ing. Arben Drenthaj
ing. Ermal Spahiu
ing. Ina Hoxhaj

K.2138/2
N.5628/12

Firma / Signature:
Lexoj dhe aprovoj / I read and approve.

**BURHAN TURKESHI
ERMIR GJOKA**

Hydro-Mechanical Engineering
Inzhineri Hidro-Mekanik dhe MNZ

K.1873/4
M.1174/2

Firma / Signature:
Lexoj dhe aprovoj / I read and approve.

**BASHKIM SHAHINAJ
BESART DALLIU**

Electrical Engineering
Inzhineri Elektrik

E.0185/6
E.1412/2

Firma / Signature:
Lexoj dhe aprovoj / I read and approve.

ALL DIMENSIONS HAVE TO BE VERIFIED BY THE CONTRACTOR ON THE CONSTRUCTION SITE
IMPORTANT: These drawings are property of IRI. Rruga DERVISH HIMA, nr 8 kati i pare - 1001 TIRANA. Copy, multiplication or distribution inbetween parties of these plans (or any part of it) without written permission of IRI is prohibited.

TË GJITHA DIMENSIONET DUHET TË VERIFIKOHEN NGA KONTRAKTORI NË VËND
E RËNDËSISHME: Këto vizatime janë pronë e IRI. Rruga DERVISH HIMA, nr 8 kati i parë - 1001 TIRANË. Kopjimi, shumfishimi apo shpërndarja e këtyre vizatimeve (apo pjesëve të tyre) pa lejen me shkrim të IRI është e ndaluar.

issuer A	plan number: A.00.1	TITULLI / Title: Render _ Kolegji	
Faza: LN	data: 2026	shkalla e vizatimit: 1:200	formati: A3



LEGJENDA/ Legenda:

SHENIME/ Notes:

PROJEKTI / Project:
Ngritja e Infrastrukturës Arsimore të Liceut Franko-Shqiptar të Shkencave dhe Inovacionit, Bashkia Korçë / Establishment of the Educational Infrastructure of the Franco-Albanian Lyceum of Sciences and Innovation, Municipality of Korça

Klienti: FONDI SHQIPTAR I ZHVILLIMIT
Client: ALBANIAN DEVELOPMENT FUND

IRI

Local Architecture Office (LOC)
Studio Lokale Arkitekture (VEND)
Gent Agoll

N.6844

Firma / Signature:
Lexoj dhe aprovoj / I read and approve.

ARCHISPACE

Local Architecture Office (LOC)
Studio Lokale Arkitekture (VEND)
Rais Petrela

N.6732/14

Firma / Signature:
Lexoj dhe aprovoj / I read and approve.

SPHAERA

Local Architecture Office (LOC)
Studio Lokale Arkitekture (VEND)
Ajdin Topore

N.4654/14

Firma / Signature:
Lexoj dhe aprovoj / I read and approve.

**LORENC BEGAJ
AVE CONSULTING**

Construction Studio
Studio Konstruksioni
ing. Arben Dervishaj
ing. Ermal Spahiu
ing. Ina Hotaj

K.2138/2
N.5628/12

Firma / Signature:
Lexoj dhe aprovoj / I read and approve.

**BURHAN TURKESHI
ERMIR GJOKA**

Hydro-Mechanical Engineering
Inzhineri Hidro-Mekanik dhe MNZ

K.1873/4
M.1174/2

Firma / Signature:
Lexoj dhe aprovoj / I read and approve.

**BASHKIM SHAHINAJ
BESART DALLIU**

Electrical Engineering
Inzhineri Elektrik

E.0185/6
E.1412/2

Firma / Signature:
Lexoj dhe aprovoj / I read and approve.

ALL DIMENSIONS HAVE TO BE VERIFIED BY THE CONTRACTOR ON THE CONSTRUCTION SITE
IMPORTANT: These drawings are property of IRI. Rruga DERVISH HIMA, nr 8 kati i pare – 1001 TIRANA. Copy, multiplication or distribution inbetween parties of these plans (or any part of it) without written permission of IRI is prohibited.

TË GJITHA DIMENSIONET DUHET TË VERIFIKOHEN NGA KONTRAKTORI NË VËND
E RËNDËSISHME: Këto vizatime janë pronë e IRI, Rruga DERVISH HIMA, nr 8 kati i parë – 1001 TIRANË. Kopjimi, shumfishimi apo shpërndarja e këtyre vizatimeve (apo pjesëve të tyre) pa lejen me shkrim të IRI është e ndaluar.

issuer A	plan number: A.00.1	TITULLI / Title: Render _ Kolegji	
Faza: LN	data: 2026	shkalla e vizatimit: 1:200	formati: A3

N



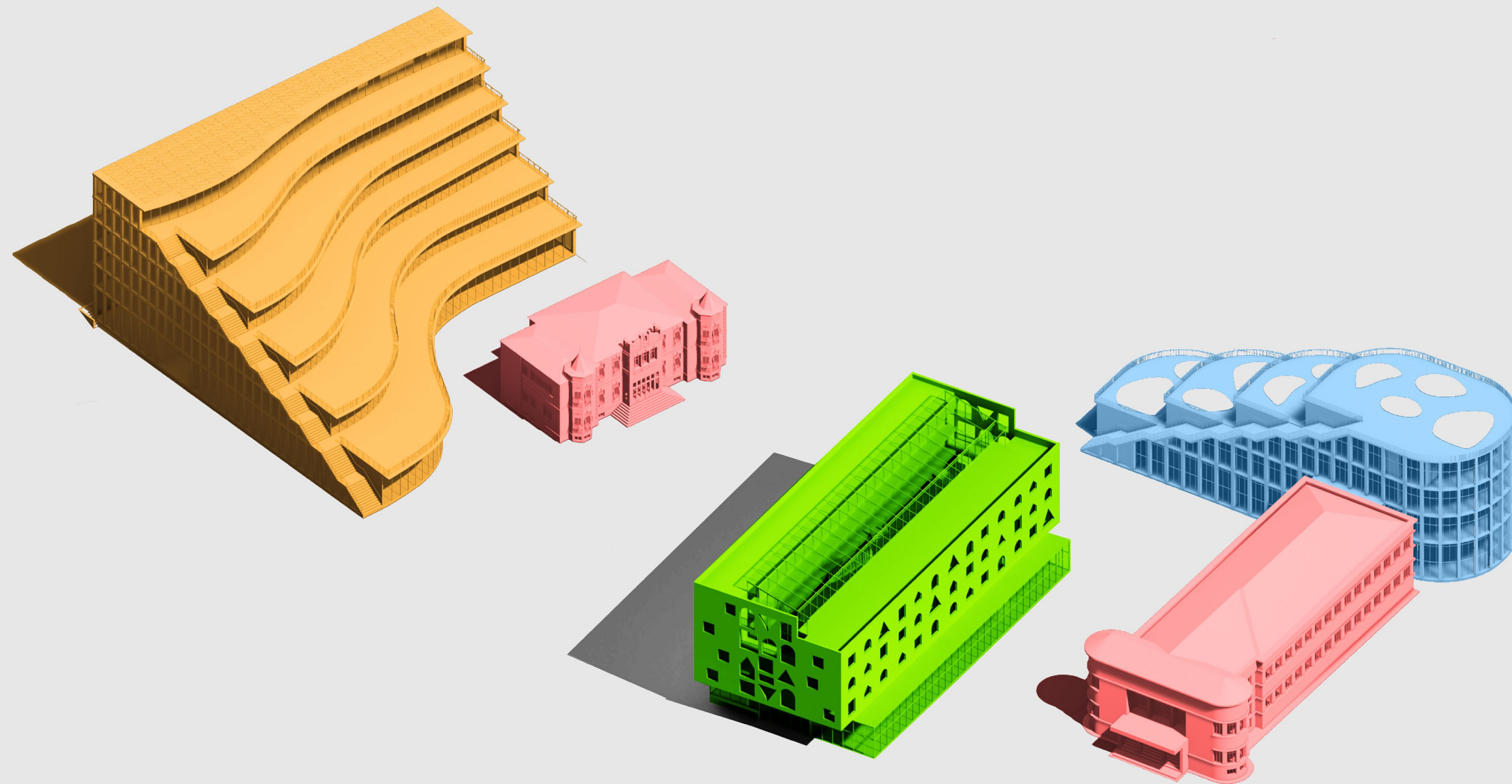

LEGJENDA/ Legenda:

SHËNIME/ Notes:

PROJEKTI / Project:
 Ngritja e Infrastrukturës Arsimore të Liceut Franko-Shqiptar të Shkencave dhe Inovacionit, Bashkia Korçë / Establishment of the Educational Infrastructure of the Franco-Albanian Lyceum of Sciences and Innovation, Municipality of Korça

Klienti: FONDI SHQIPTAR I ZHVILLIMIT
 Client: ALBANIAN DEVELOPMENT FUND

IRI Local Architecture Office (LOC) Studio Lokale Arkitekture (VEND) Gent Agolli	N.6844	Firma / Signature: Lexoj dhe aprovoj / I read and approve.
ARCHISPACE Local Architecture Office (LOC) Studio Lokale Arkitekture (VEND) Rais Petrela	N.6732/14	Firma / Signature: Lexoj dhe aprovoj / I read and approve.
SPHAERA Local Architecture Office (LOC) Studio Lokale Arkitekture (VEND) Ajdin Topore	N.4654/14	Firma / Signature: Lexoj dhe aprovoj / I read and approve.
LORENC BEGAJ AVE CONSULTING Construction Studio Studio Konstruksioni ing. Arben Demishaj ing. Ermal Spahiu ing. Ina Hoxhaj	K.2138/2 N.5628/12	Firma / Signature: Lexoj dhe aprovoj / I read and approve.
BURHAN TURKESHI ERMIR GJOKA Hydro-Mechanical Engineering Inzhinieri Hidro-Mekanik dhe MNZ	K.1873/4 M.1174/2	Firma / Signature: Lexoj dhe aprovoj / I read and approve.
BASHKIM SHAHINAJ BESART DALLIU Electrical Engineering Inzhinieri Elektrik	E.0185/6 E.1412/2	Firma / Signature: Lexoj dhe aprovoj / I read and approve.

ALL DIMENSIONS HAVE TO BE VERIFIED BY THE CONTRACTOR ON THE CONSTRUCTION SITE
 IMPORTANT: These drawings are property of IRI, Rruga DERSHVI HIMA, nr 8 kati i pare – 1001 TIRANA. Copy, multiplication or distribution inbetween parties of these plans (or any part of it) without written permission of IRI is prohibited.

TË GJITHA DIMENSIONET DUHET TË VERIFIKOHEN NGA KONTRAKTORI NË VËND
 E RËNDËSISHME: Këto vizatime janë pronë e IRI, Rruga DERSHVI HIMA, nr 8 kati i parë – 1001 TIRANË. Kopjimi, shumfishimi apo shpërndarja e këtyre vizatimeve (apo pjesëve të tyre) pa lejen me shkrim të IRI është e ndaluar.

issuer A	plan number: A.00.1	TITULLI / Title: Render _ AKSONOMETRI / AXONOMETRIC VIEW
--------------------	------------------------	--

Faza: LN	data: 2026	shkalla e vizatimit: 1:200	formati: A3	N ↑ ○
-------------	---------------	-------------------------------	----------------	-------------

ARCHITECTURE PROJECT

Project:

Establishment of the Educational Infrastructure of the Franco-Albanian Lyceum of Sciences and Innovation, Municipality of Korça

New School (Collage)

Phase: Building permit

Client: ALBANIAN DEVELOPMENT FUND

Prepered:

ARCHISPACE + iRI + SPHAERA

2026

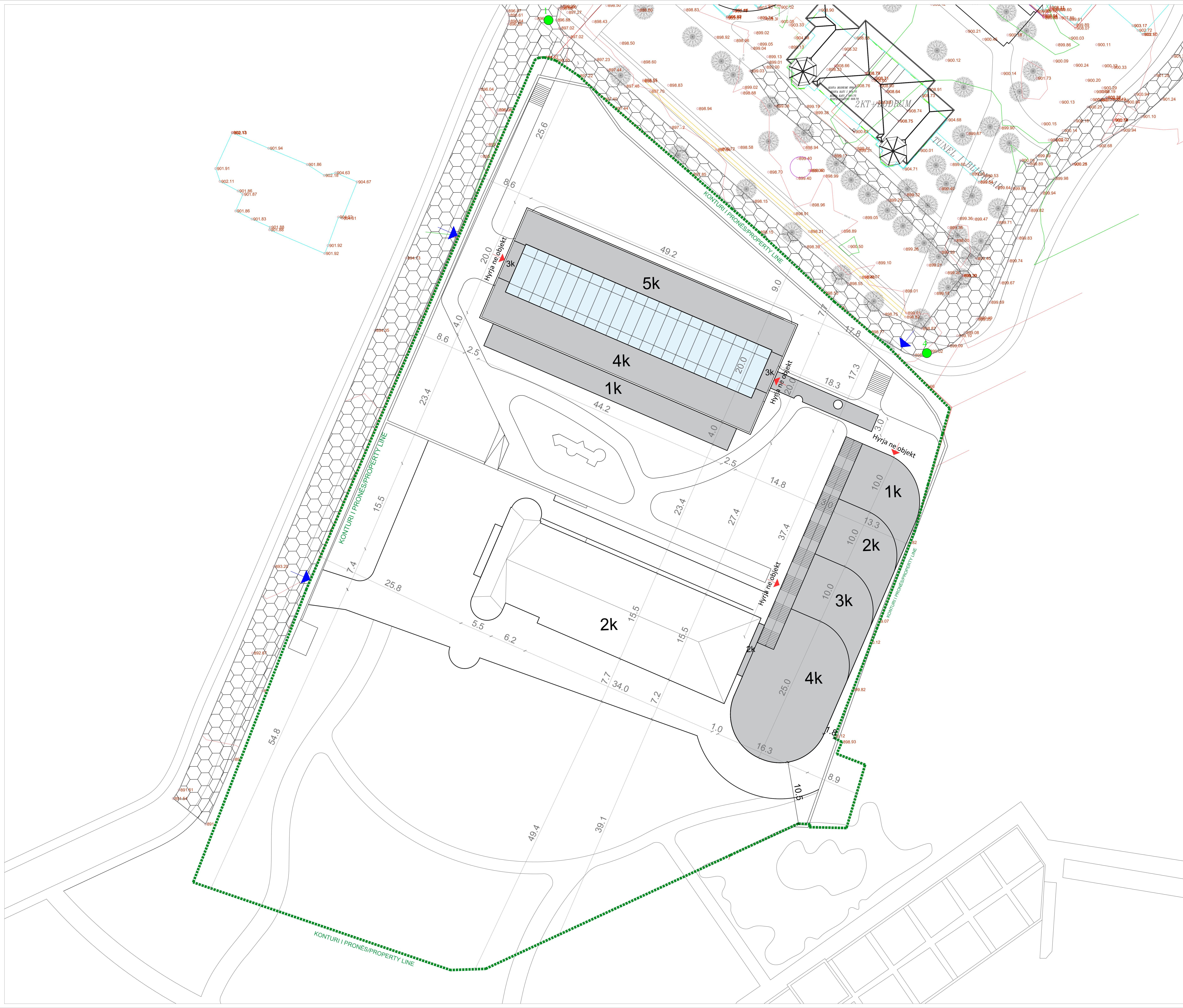

- LEGJENDA / LEGEND:**
- - - KUFIRI I PRONES / PROPERTY LINE
 - HYRJE NE OBJEKT / ENTRANCE
 - NJJOLLA E OBJEKTIT / BUILDING
 - HYRJE NE PRONE / PROPERTY ENTRANCE
 - NJJOLLA E OBJEKTIT EKZISTUES / EXISTING BUILDING

PROJEKTI / Project:
 Ngritja e Infrastrukturës Arsimore të Liceut Franko-Shqiptar të Shkencave dhe Inovacionit, Bashkia Korçë / Establishment of the Educational Infrastructure of the Franco-Albanian Lyceum of Sciences and Innovation, Municipality of Korça

Klienti: FONDI SHQIPTAR I ZHVILLIMIT
 Client: ALBANIAN DEVELOPMENT FUND

iRI <small>Local Architecture Office Studio Lokale Arkitektura Georgiy</small>	N.6844	Firma / Signature: Lexoj dhe aprovj / I read and approve.
ARCHISPACE <small>Local Architecture Office Studio Lokale Arkitektura Flav Pirova</small>	N.6732/14	Firma / Signature: Lexoj dhe aprovj / I read and approve.
SPHAERA <small>Local Architecture Office Studio Lokale Arkitektura Aldat Topani</small>	N.4654/14	Firma / Signature: Lexoj dhe aprovj / I read and approve.
LORENC BEGAJ AVE CONSULTING <small>Consultor i Shkencave Studio Konstruksione Ing. Altin Dervishi Ing. Erind Dushaj Ing. Iva Hoxha</small>	K.2138/2 N.5628/12	Firma / Signature: Lexoj dhe aprovj / I read and approve.
BURHAN TURKESHI ERMIR GJOKA <small>Hydro-Mechanical Engineering Inzhineri Hidro-Mekanik dhe MZ</small>	K.1873/4 M.1174/2	Firma / Signature: Lexoj dhe aprovj / I read and approve.
BASHKIM SHAHINAJ BESART DALLIU <small>Electrical Engineering Inzheneri Elektrik</small>	E.0185/6 E.1412/2	Firma / Signature: Lexoj dhe aprovj / I read and approve.

ALL DIMENSIONS HAVE TO BE VERIFIED BY THE CONTRACTOR ON THE CONSTRUCTION SITE.
 IMPORTANT: These drawings are property of iRI. Rruga DERSVISHI HIMA, nr 8 kat i pare - 1001 TIRANA. Copy, multiplication or distribution in whole or in part of these plans (or any part of it) without written permission of iRI is prohibited.

TE GJITHA DIMENSIONET DUHET TE VERIFIKOHEN NGA KONTRAKTORI NE VEND.
 E RENDËSISHME: Këtu vizatimet janë pronë të iRI. Rruga DERSVISHI HIMA, nr 8 kat i pare - 1001 TIRANE. Kopimi, shumëllojimi apo shpërndarja e këtyre vizatimeve (apo pjesëve të tyre) pa lejen me shkrim të iRI-së është e ndaluar.

Issuer: A	plan number: A.00.1	TITULLI / Title: PLANVENDOSJE / SITE PLAN	
Faza: LN	data: 2026	shkalla e vizatimit: 1:200	formati: A0

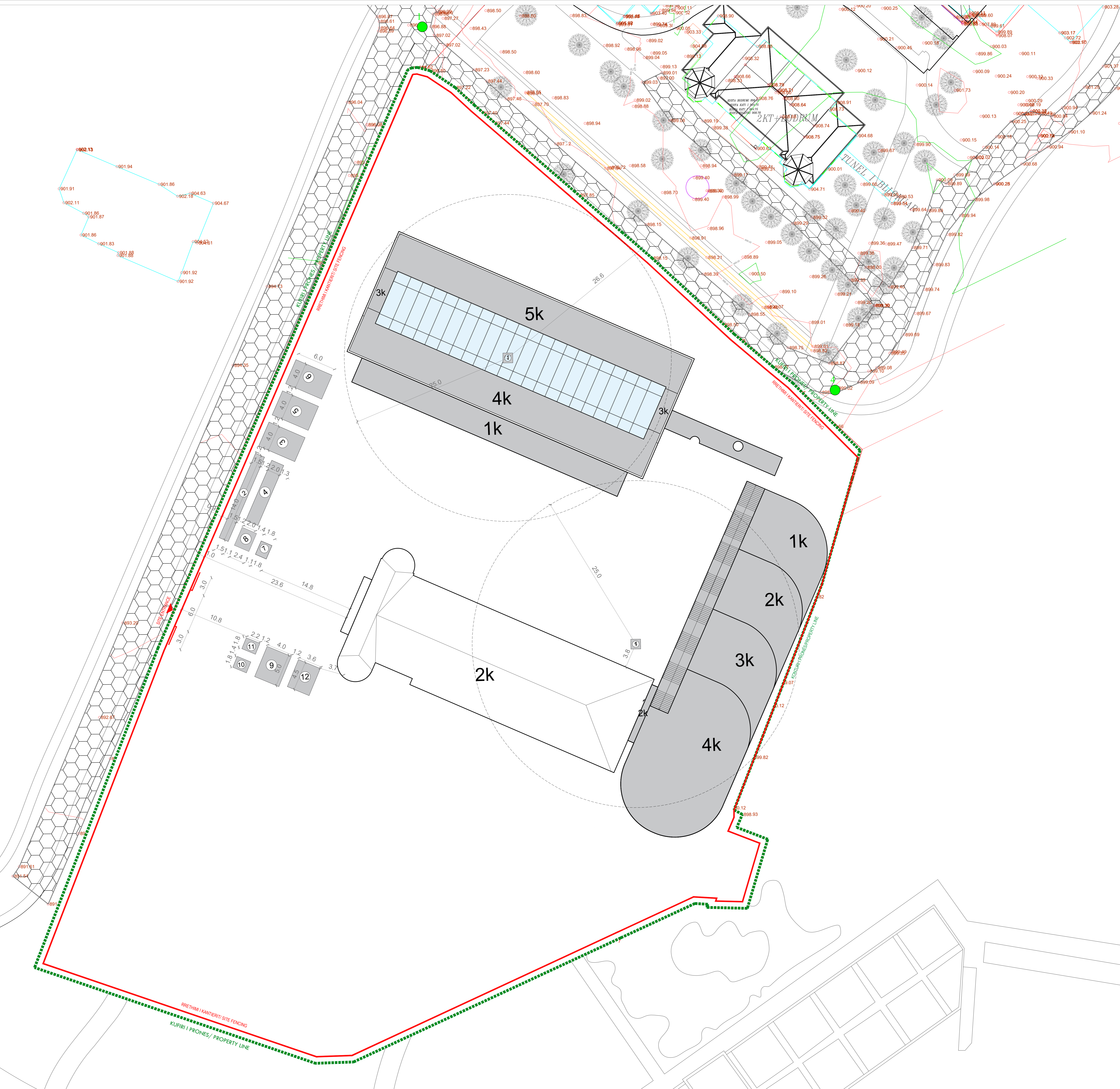

LEGJENDA/ Legenda:

- konturi i pronës/ property line
- rrethimi i kantierit/ site fencing
- ① vinçi/ crane
- ② shesh për hekurin/ space for the iron
- ③ shesh për tullat/ space for the bricks
- ④ shesh për pllakën/ space for the tiles
- ⑤ shesh për llaçin/ space for the mortar
- ⑥ shesh për çimenton/ space for the cement
- ⑦ grumbullim mbeturinash/ space for the trash
- ⑧ depozita/ deposit
- ⑨ zyra/ office
- ⑩ roja/ security
- ⑪ tualet/ toilet
- ⑫ garderoba/ changig room

DETAJ I RRETHIMIT TE KANTIERIT/ SITE FENCING DETAIL

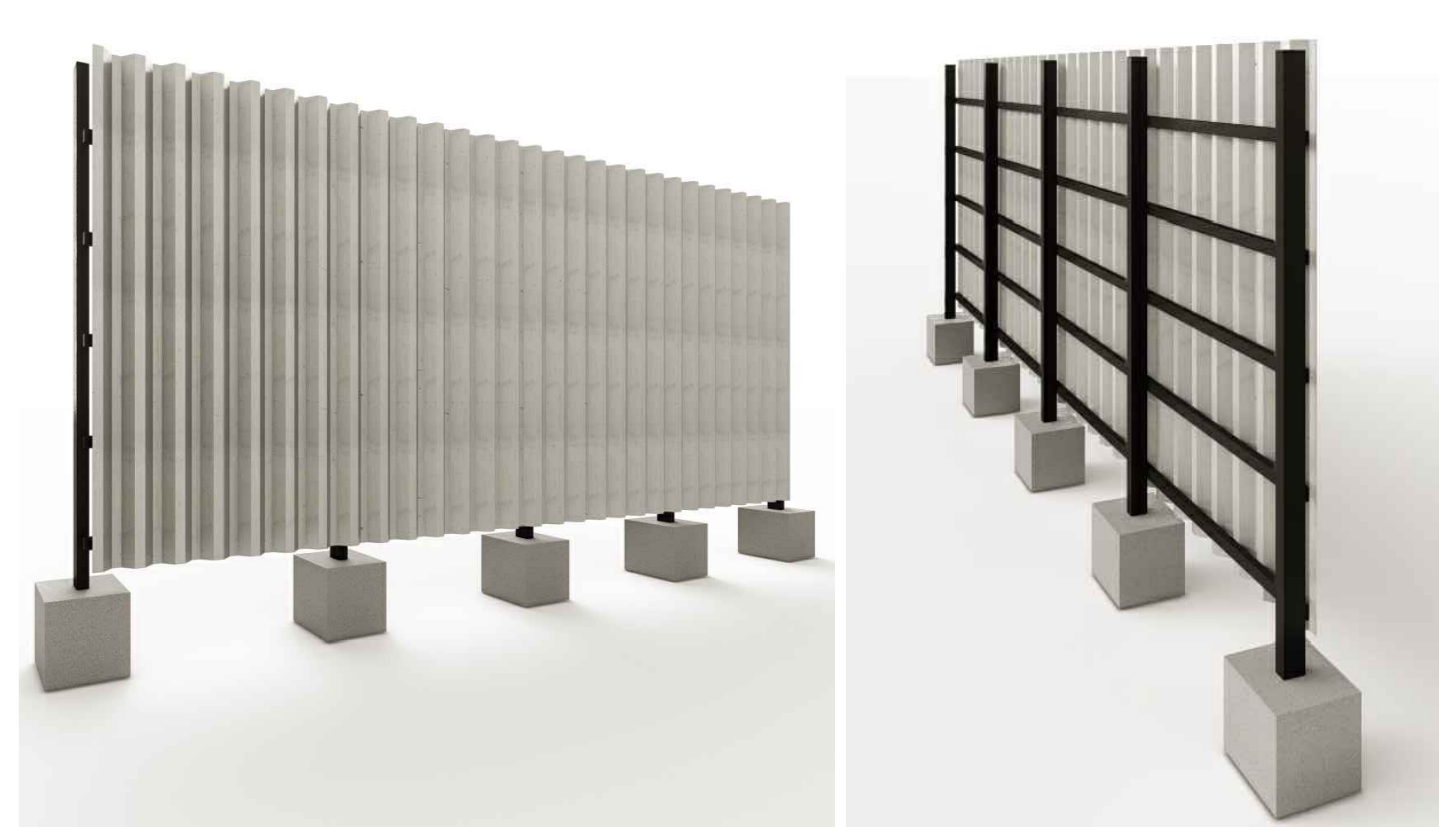
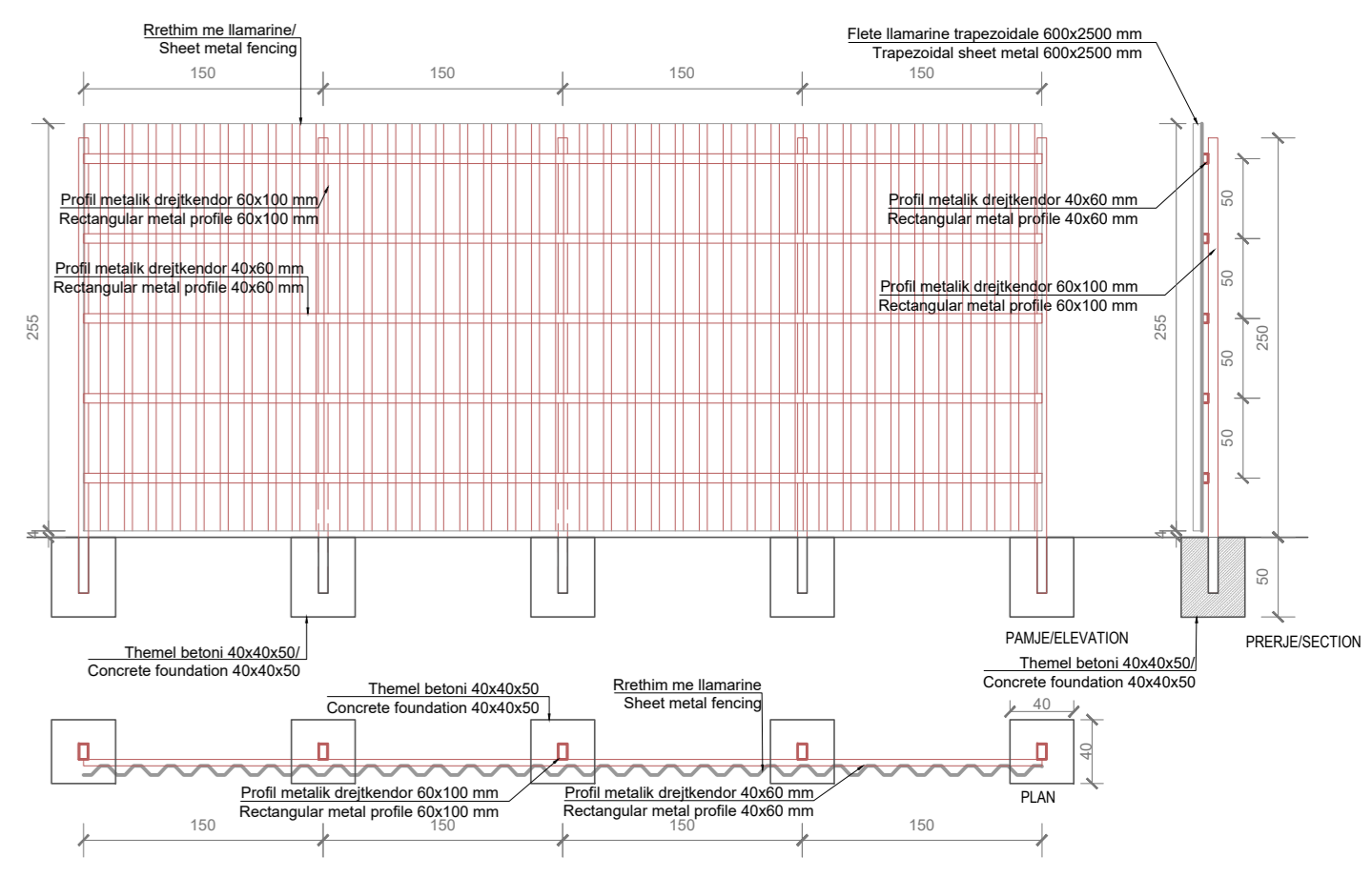

PROJEKTI / Project:
Ngritja e Infrastrukturës Arsimore të Liceut Franko-Shqiptar të Shkencave dhe Inovacionit, Bashkia Korçë / Establishment of the Educational Infrastructure of the Franco-Albanian Lyceum of Sciences and Innovation, Municipality of Korça

Klienti: FONDI SHQIPTAR I ZHVILLIMIT
Client: ALBANIAN DEVELOPMENT FUND

iRI Local Architecture Office Studio Luljeta Architects Shkup, North Macedonia	N.6844	Firma / Signature: Lexoj dhe aprovuj / I read and approve.
ARCHISPACE Local Architecture Office Studio Luljeta Architects Shkup, North Macedonia	N.6732/14	Firma / Signature: Lexoj dhe aprovuj / I read and approve.
SPHAERA Local Architecture Office Studio Luljeta Architects Shkup, North Macedonia	N.4654/14	Firma / Signature: Lexoj dhe aprovuj / I read and approve.
LORENC BEGAJ AVE CONSULTING Construction Studio Studio Korçezina Rr. Adem Demiri No. 2, Korça, Albania	K.2138/2 N.5628/12	Firma / Signature: Lexoj dhe aprovuj / I read and approve.
BURHAN TURKESHI ERMIR GJOKA Hydro-Mechanical Engineering Inshtruesi Hekuror dhe Shkencor	K.1873/4 M.1174/2	Firma / Signature: Lexoj dhe aprovuj / I read and approve.
BASHKIM SHAHINAJ BESART DALLIU Electrical Engineering Inshtruesi Elektrik	E.0185/6 E.1412/2	Firma / Signature: Lexoj dhe aprovuj / I read and approve.

ALL DIMENSIONS HAVE TO BE VERIFIED BY THE CONTRACTOR ON THE CONSTRUCTION SITE.
SHËNOTIM: Të gjitha dimensionet duhet të verifikohen nga kontraktori në vend.
E-BRËQËSËSIME: Këtu ricorren pjesë prej e-RI, Shkup dhe/ose/SHK, në 3 kullë për - 1001 TRANA. Copy, multiplication or distribution between parties of these plans or any part of it without written permission of iRI is prohibited.

Issuer: A	plan number: A.00.2	TITULLI / Title: PLANI I KANTIERIT / SITE WORKS PLAN
Faza: LN	data: 2026	shkalla e vizatimit: 1:200
		formati: A0



Legjende/ Legend

- Kufi prone/ Property Line
- peme ekzistuese/ existing tree
- HYRJE NE PRONE / PROPERTY ENTRANCE
- PEME QE HIQEN / REMOVED TREES
- MURE SISTEIMI QE PRISHEN/ REMOVED LANDSCAPE WALLS
- GERMIM PER HIDROIZOLIMIN E THEMELEVE/ ESCAVATION FOR FOUNDATION INSULATION

PROJEKTI / Project:
 Ngritja e Infrastrukturës Arsimore të Liceut Franko-Shqiptar të Shkencave dhe Inovacionit, Bashkia Korçë / Establishment of the Educational Infrastructure of the Franco-Albanian Lyceum of Sciences and Innovation, Municipality of Korça

Klienti: FONDI SHQIPTAR I ZHVILLIMIT
 Client: ALBANIAN DEVELOPMENT FUND

iRI <small>Local Architecture Office Studio Lokale Arkitekture Georgjani</small>	N.6844	Firma / Signature: Lexoj dhe aprovoj / I read and approve.
ARCHISPACE <small>Local Architecture Office Studio Lokale Arkitekture Rex Pirova</small>	N.6732/14	Firma / Signature: Lexoj dhe aprovoj / I read and approve.
SPHAERA <small>Local Architecture Office Studio Lokale Arkitekture Ajet Topani</small>	N.4654/14	Firma / Signature: Lexoj dhe aprovoj / I read and approve.
LORENC BEGAJ AVE CONSULTING <small>Consultor/ Shërbim Studio Konsultime Ing. Arben Dervishi Rr. Ervin Dajçiqi Tj. Nr.100/1</small>	K.2138/2 N.5628/12	Firma / Signature: Lexoj dhe aprovoj / I read and approve.
BURHAN TURKESHI ERMIR GJOKA <small>Hydro-Mechanical Engineering Inzhineri Hidro-Mekanik dhe MZ</small>	K.1873/4 M.1174/2	Firma / Signature: Lexoj dhe aprovoj / I read and approve.
BASHKIM SHAHINAJ BESART DALLIU <small>Electrical Engineering Inzheneri Elektrik</small>	E.0185/6 E.1412/2	Firma / Signature: Lexoj dhe aprovoj / I read and approve.





ALL DIMENSIONS HAVE TO BE VERIFIED BY THE CONTRACTOR ON THE CONSTRUCTION SITE.
 IMPORTANT: These drawings are property of iRI, Rruga DERSVISH HIMA, nr 8 kati i pare - 1001 TIRANA, Copy, multiplication or distribution in whatever parties of these plans (or any part of it) without written permission of iRI is prohibited.

TË GJITHA DIMENSIONET DUHET TË VERIFIKOHEN NGA KONTRAKTORI NË VËND.
 E RËNDËSISHME: Këto vizatime janë pronë e iRI, Rruga DERSVISH HIMA, nr 8 kati i parë - 1001 TIRANË, Kopimi, shumëllojshmëri apo shpërndarje e këtyre vizatimeve (apo pjesëve të tyre) pa lejen me shkrim të iRI është e ndaluar.

Issuer: A	plan number: A.00.4	TITULLI / Title: NDRYSHIME NE SISTEMIN EKZISTUES/ CHANGES IN CURRENT LANDSCAPE PLAN
Faza: LN	data: 2026	shkalla e vizatimit: 1:200
		formati: A0

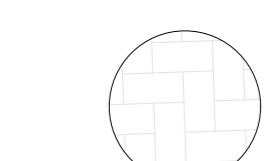
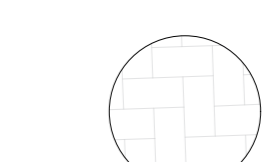
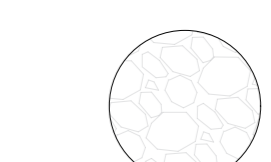
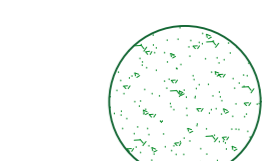
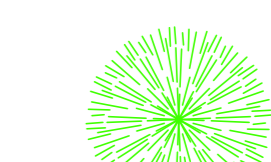

Legjende/ Legend

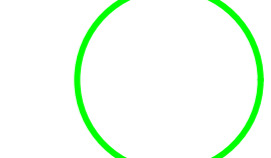
-  Kufi prone/ Property Line
-  Shtim me pllake (ekzistues)/ Tile pavement (existing)
-  Shtim me pllake 385 m²/ Tile pavement 385 m²
-  Shtim me zhavorr 1141 m²/ Gravel pavement 1141 m²
-  Siperfaqe gjelberimi 1578 m²/ Surface planted with grass 1578 m²
-  peme ekzistuese/ existing tree
-  ndricues gjelberimi te ulet/ low green lighting
-  stol/ stool
-  kosh mbeturinash/ trash can
-  HYRJE NE PRONE / PROPERTY ENTRANCE
-  PEME QE RIMBILLEN / REPLANTED TREES

PROJEKTI / Project:
 Ngritja e Infrastrukturës Arsimore të Liceut Franko-Shqiptar të Shkencave dhe Inovacionit, Bashkia Korçë / Establishment of the Educational Infrastructure of the Franco-Albanian Lyceum of Sciences and Innovation, Municipality of Korça

Klienti: FONDI SHQIPTAR I ZHVILLIMIT
 Client: ALBANIAN DEVELOPMENT FUND

iRI <small>Local Architecture Office Studio Lokale Arkitekture Georgjaj</small>	N.6844	Firma / Signature: Lexoj dhe aprovoj / I read and approve.
ARCHISPACE <small>Local Architecture Office Studio Lokale Arkitekture Rexhepaj</small>	N.6732/14	Firma / Signature: Lexoj dhe aprovoj / I read and approve.
SPHAERA <small>Local Architecture Office Studio Lokale Arkitekture Ajetaj Topaj</small>	N.4654/14	Firma / Signature: Lexoj dhe aprovoj / I read and approve.
LORENC BEGAJ AVE CONSULTING <small>Consultor/Studio Studio Konsulent Ing. Arben Dervishi Ing. Ervil Dervishi Ing. Nita Hoxha</small>	K.2138/2 N.5628/12	Firma / Signature: Lexoj dhe aprovoj / I read and approve.
BURHAN TURKESHI ERMIR GJOKA <small>Hydro-Mechanical Engineering Inzhineri Hidro-Mekanik dhe IMZ</small>	K.1873/4 M.1174/2	Firma / Signature: Lexoj dhe aprovoj / I read and approve.
BASHKIM SHAHINAJ BESART DALLIU <small>Electrical Engineering Inzhineri Elektrik</small>	E.0185/6 E.1412/2	Firma / Signature: Lexoj dhe aprovoj / I read and approve.

ALL DIMENSIONS HAVE TO BE VERIFIED BY THE CONTRACTOR ON THE CONSTRUCTION SITE.
 IMPORTANT: These drawings are property of iRI. Rruga DERSVISH HIMA, nr 8 kat i pare - 1001 TIRANA, Copy, multiplication or distribution in whole or in part of these plans (or any part of it) without written permission of iRI is prohibited.

TE GJITHA DIMENSIONET DUHET TE VERIFIKOHEN NGA KONTRAKTORI NE VEND.
 E RENDËSISHME: këto vizatime janë pronë e iRI, Rruga DERSVISH HIMA, nr 8 kat i pare - 1001 TIRANE, Kopimi, shumëllojshmëri apo shpërndarje e këtyre vizatimeve (apo pjesëve të tyre) pa lejen me shkrim të iRI është e ndaluar.

Issuer: A	plan number: A.00.4	TITULLI / Title: PLANI I SISTEMIMIT/ LANDSCAPE PLAN
Faza: LN	data: 2026	shkalla e vizatimit: 1:200
		formati: A0

Konvikt
Dormitory

Kati -1 / Floor -1

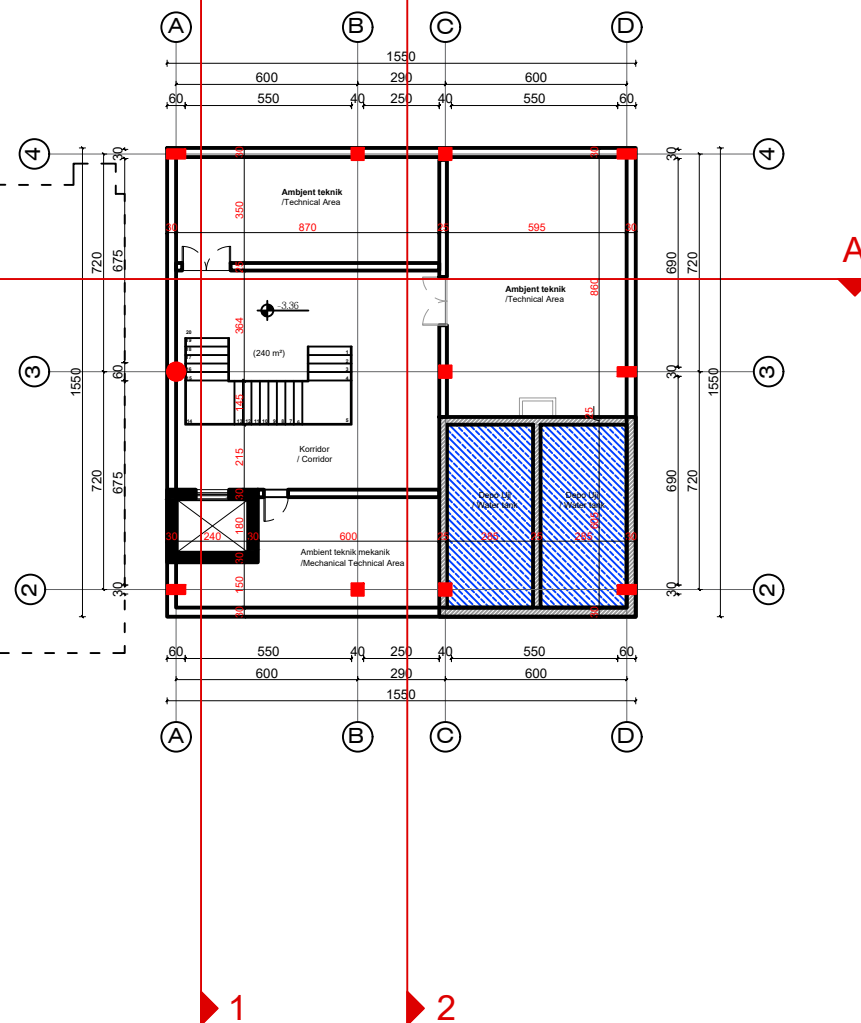
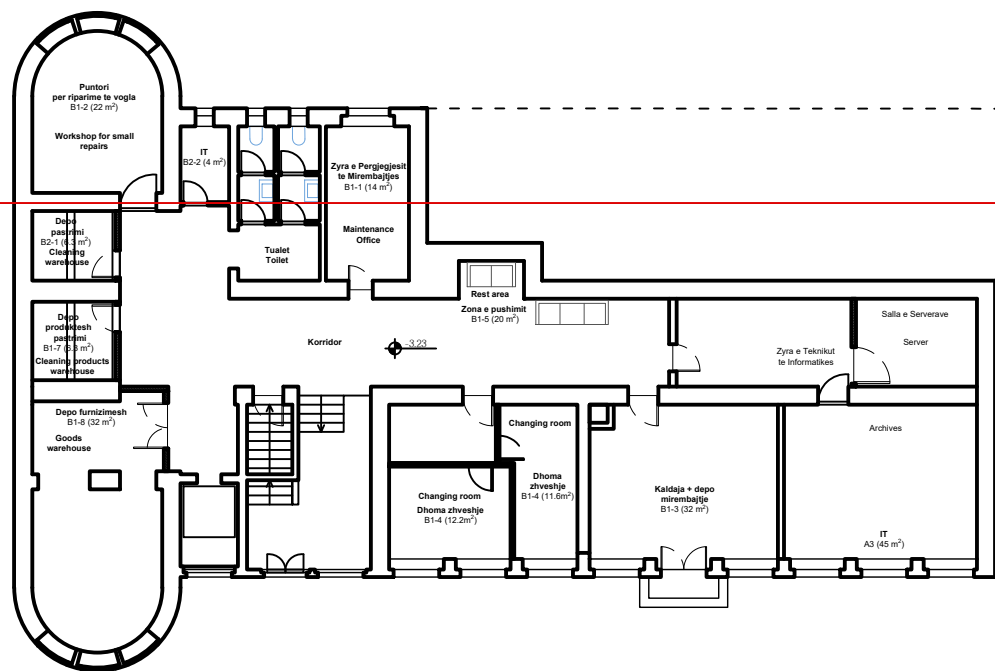

LEGJENDA/ Legenda:

SHËNIME/ Notes:

PROJEKTI / Project:
Ngritja e Infrastrukturës Arsimore të Liceut Franko-Shqiptar të Shkencave dhe Inovacionit, Bashkia Korçë / Establishment of the Educational Infrastructure of the Franco-Albanian Lyceum of Sciences and Innovation, Municipality of Korça

Klienti: FONDI SHQIPTAR I ZHVILLIMIT
Client: ALBANIAN DEVELOPMENT FUND

IRI N.6844 Firma / Signature:
Lexoj dhe aprovoj / I read and approve.
Local Architecture Office (LOC)
Studio Lokale Arkitekture (VEND)
Gent Agolli

ARCHISPACE N.6732/14 Firma / Signature:
Lexoj dhe aprovoj / I read and approve.
Local Architecture Office (LOC)
Studio Lokale Arkitekture (VEND)
Rais Petrela

SPHAERA N.4654/14 Firma / Signature:
Lexoj dhe aprovoj / I read and approve.
Local Architecture Office (LOC)
Studio Lokale Arkitekture (VEND)
Ajdin Topore

LORENC BEGAJ AVE CONSULTING K.2138/2 N.5628/12 Firma / Signature:
Lexoj dhe aprovoj / I read and approve.
Construction Studio
Studio Konstruksioni
Ing. Arben Demushaj
Ing. Ermal Spahiu
Ing. Ina Hoxhaj

BURHAN TURKESHI ERMIR GJOKA K.1873/4 M.1174/2 Firma / Signature:
Lexoj dhe aprovoj / I read and approve.
Hydro-Mechanical Engineering
Inzhinieri Hidro-Mekanik dhe MNZ

BASHKIM SHAHINAJ BESART DALLIU E.0185/6 E.1412/2 Firma / Signature:
Lexoj dhe aprovoj / I read and approve.
Electrical Engineering
Inzhinieri Elektrik

ALL DIMENSIONS HAVE TO BE VERIFIED BY THE CONTRACTOR ON THE CONSTRUCTION SITE
TË GJITHA DIMENSIONET DUHET TË VERIFIKOHEN NGA KONTRAKTORI NË VEND
IMPORTANT: These drawings are property of IRI. Rruga DERSHVI HIMA, nr 8 kati i pare - 1001 TIRANA. Copy, multiplication or distribution inbetween parties of these plans (or any part of it) without written permission of IRI is prohibited.
E RËNDËSISHME: Këto vizatime janë pronë e IRI, Rruga DERSHVI HIMA, nr 8 kati i parë - 1001 TIRANË. Kopjimi, shumfishimi apo shpërndarja e këtyre vizatimeve (apo pjesëve të tyre) pa lejen me shkrim të IRI është e ndaluar.

issuer A	plan number: A.00.1	TITULLI / Title: PLANI I KATIT -1 (nentoke) teknik _ Shkolla
--------------------	------------------------	--

Faza: LN	data: 2026	shkalla e vizatimit: 1:250	formati: A3
-------------	---------------	-------------------------------	----------------



Konvikt
Dormitory

Kati -1 / Floor -1

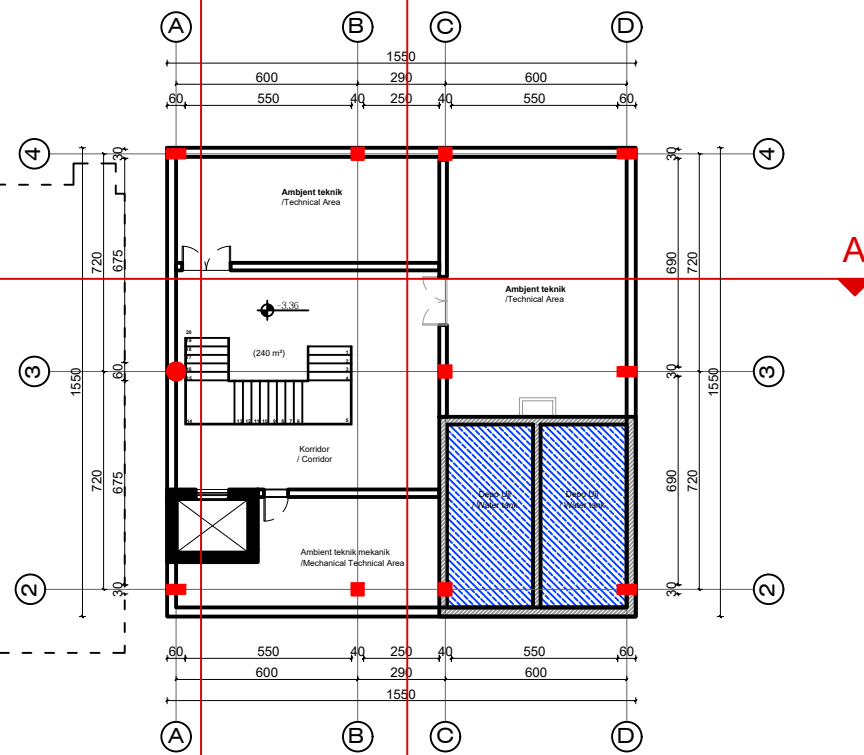
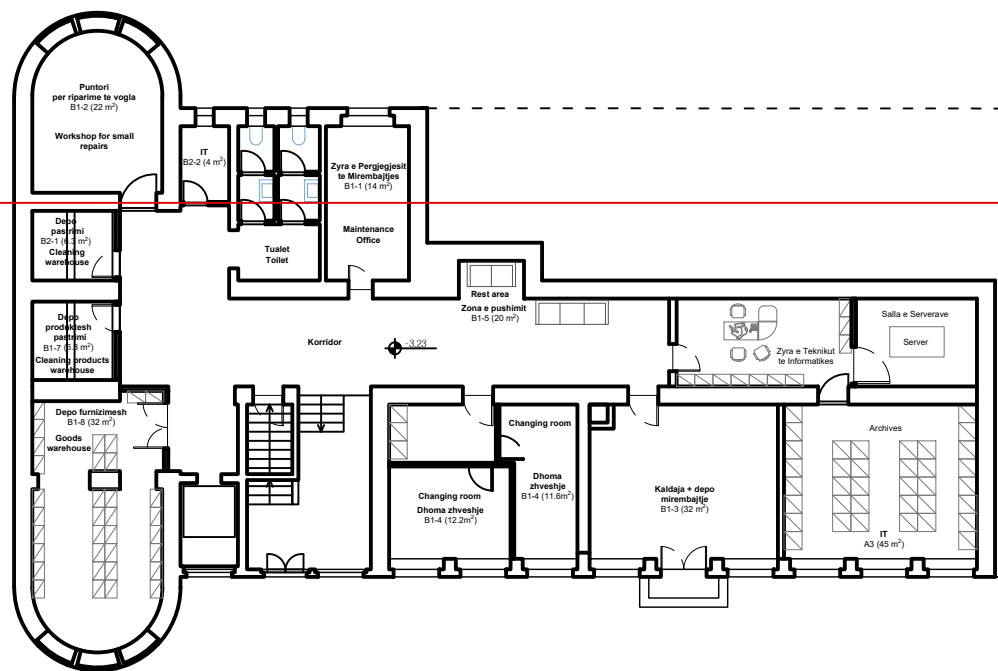

LEGJENDA/ Legenda:

SHËNIME/ Notes:

PROJEKTI / Project:
Ngritja e Infrastrukturës Arsimore të Liceut Franko-Shqiptar të Shkencave dhe Inovacionit, Bashkia Korçë / Establishment of the Educational Infrastructure of the Franco-Albanian Lyceum of Sciences and Innovation, Municipality of Korça

Klienti: FONDI SHQIPTAR I ZHVILLIMIT
Client: ALBANIAN DEVELOPMENT FUND

IRI N.6844 Firma / Signature:
Lexoj dhe aprovoj / I read and approve.
Local Architecture Office (LOC)
Studio Lokale Arkitekture (VEND)
Gent Agolli

ARCHISPACE N.6732/14 Firma / Signature:
Lexoj dhe aprovoj / I read and approve.
Local Architecture Office (LOC)
Studio Lokale Arkitekture (VEND)
Rais Petrela

SPHAERA N.4654/14 Firma / Signature:
Lexoj dhe aprovoj / I read and approve.
Local Architecture Office (LOC)
Studio Lokale Arkitekture (VEND)
Aldid Topore

**LORENC BEGAJ
AVE CONSULTING** K.2138/2
N.5628/12 Firma / Signature:
Lexoj dhe aprovoj / I read and approve.
Construction Studio
Studio Konstruksioni
Ing. Arben Dervishi
Ing. Ermal Spahiu
Ing. Ina Hoxhaj

**BURHAN TURKESHI
ERMIR GJOKA** K.1873/4
M.1174/2 Firma / Signature:
Lexoj dhe aprovoj / I read and approve.
Hydro-Mechanical Engineering
Inzhinieri Hidro-Mekanik dhe MNZ

**BASHKIM SHAHINAJ
BESART DALLIU** E.0185/6
E.1412/2 Firma / Signature:
Lexoj dhe aprovoj / I read and approve.
Electrical Engineering
Inzhinieri Elektrik

ALL DIMENSIONS HAVE TO BE VERIFIED BY THE CONTRACTOR ON THE CONSTRUCTION SITE
TË GJITHA DIMENSIONET DUHET TË VERIFIKOHEN NGA KONTRAKTORI NË VEND
IMPORTANT: These drawings are property of IRI. Rruga DERSH HIMA, nr 8 kati i pare - 1001 TIRANA. Copy, multiplication or distribution inbetween parties of these plans (or any part of it) without written permission of IRI is prohibited.
E RËNDËSISHME: Këto vizatime janë pronë e IRI. Rruga DERSH HIMA, nr 8 kati i parë - 1001 TIRANË. Kopjimi, shumfishimi apo shpërndarja e këtyre vizatimeve (apo pjesëve të tyre) pa lejen me shkrim të IRI është e ndaluar.

issuer A	plan number: A.00.1	TITULLI / Title: PLANI I KATIT -1 (nentoke) mobilim _ Shkolla
--------------------	------------------------	---

Faza: LN	data: 2026	shkalla e vizatimit: 1:250	formati: A3
-------------	---------------	-------------------------------	----------------



Konvikt Dormitory

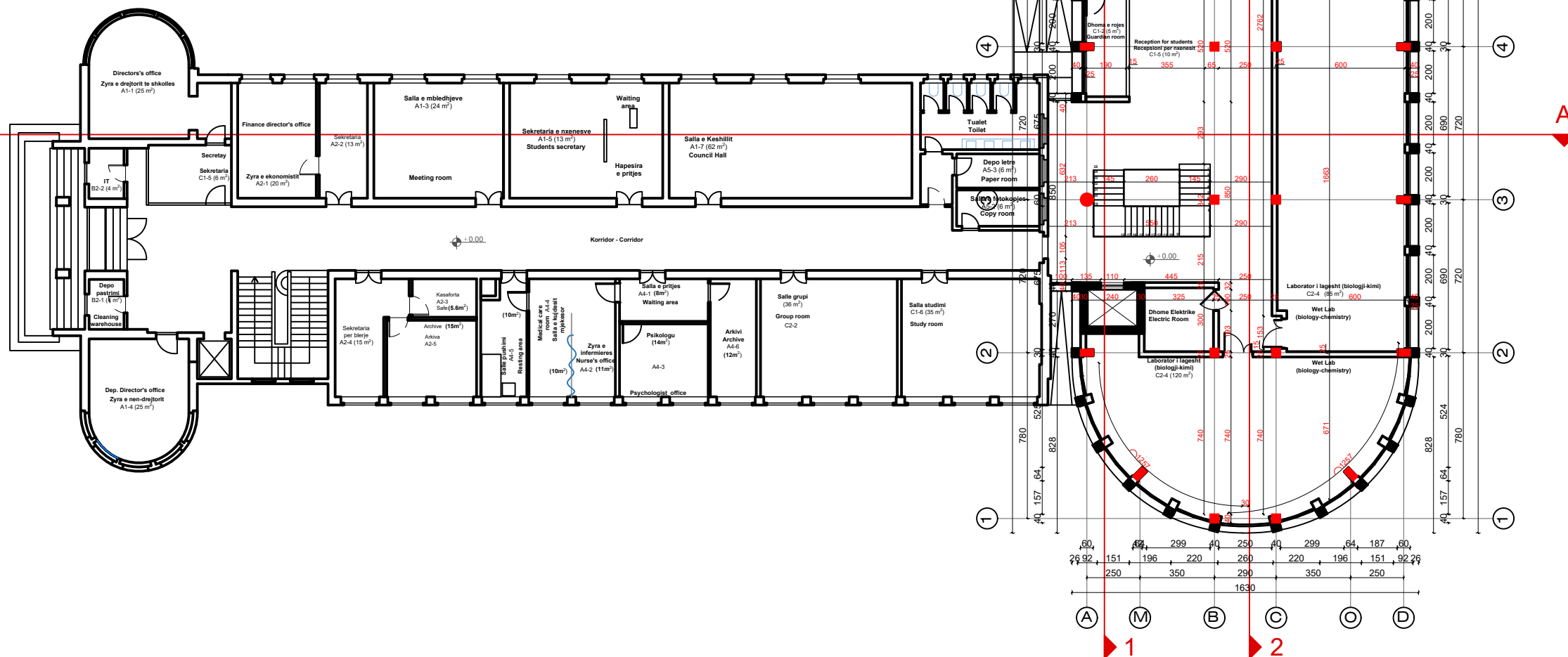

LEGJENDA/ Legenda:

SHENIME/ Notes:

PROJEKTI / Project:
Ngritja e Infrastrukturës Arsimore të Liceut Franko-Shqiptar të Shkencave dhe Inovacionit, Bashkia Korçë / Establishment of the Educational Infrastructure of the Franco-Albanian Lyceum of Sciences and Innovation, Municipality of Korça

Klienti: FONDI SHQIPTAR I ZHVILLIMIT
Client: ALBANIAN DEVELOPMENT FUND

iRI N.6844 Firma / Signature:
Lexoj dhe aprovoj / I read and approve.
Local Architecture Office (LOC)
Studio Lokale Arkitekture (VEND)
Gent Agoll

ARCHISPACE N.6732/14 Firma / Signature:
Lexoj dhe aprovoj / I read and approve.
Local Architecture Office (LOC)
Studio Lokale Arkitekture (VEND)
Rais Petrea

SPHAERA N.4654/14 Firma / Signature:
Lexoj dhe aprovoj / I read and approve.
Local Architecture Office (LOC)
Studio Lokale Arkitekture (VEND)
Ajdik Topore

**LORENC BEGAJ
AVE CONSULTING** K.2138/2
N.5628/12 Firma / Signature:
Lexoj dhe aprovoj / I read and approve.
Construction Studio
Studio Konstruksioni
ing. Arben Dervishaj
ing. Ermal Spahiu
ing. Ina Hotaj

**BURHAN TURKESHI
ERMIR GJOKA** K.1873/4
M.1174/2 Firma / Signature:
Lexoj dhe aprovoj / I read and approve.
Hydro-Mechanical Engineering
Inzhineri Hidro-Mekanik dhe MNZ

**BASHKIM SHAHINAJ
BESART DALLIU** E.0185/6
E.1412/2 Firma / Signature:
Lexoj dhe aprovoj / I read and approve.
Electrical Engineering
Inzhineri Elektrik

ALL DIMENSIONS HAVE TO BE VERIFIED BY THE CONTRACTOR ON THE CONSTRUCTION SITE
IMPORTANT: These drawings are property of iRI. Rruga DERVISH HIMA, nr 8 kati i pare - 1001 TIRANA. Copy, multiplication or distribution between parties of these plans (or any part of it) without written permission of iRI is prohibited.

TË GJITHA DIMENSIONET DUHET TË VERIFIKOHEN NGA KONTRAKTORI NË VEND
E RENDËSISHME: Këto vizatime janë pronë e iRI. Rruga DERVISH HIMA, nr 8 kati i parë - 1001 TIRANË. Kopjimi, shumfishimi apo shpërndarja e këtyre vizatimeve (apo pjesëve të tyre) pa lejen me shkrim të iRI është e ndaluar.

issuer A	plan number: A.00.1	TITULLI / Title: PLANI I KATIT 0 (perdhe) teknik _Shkolla
--------------------	------------------------	---

Faza: LN	data: 2026	shkalla e vizatimit: 1:250	formati: A3
-------------	---------------	-------------------------------	----------------



Konvikt Dormitory

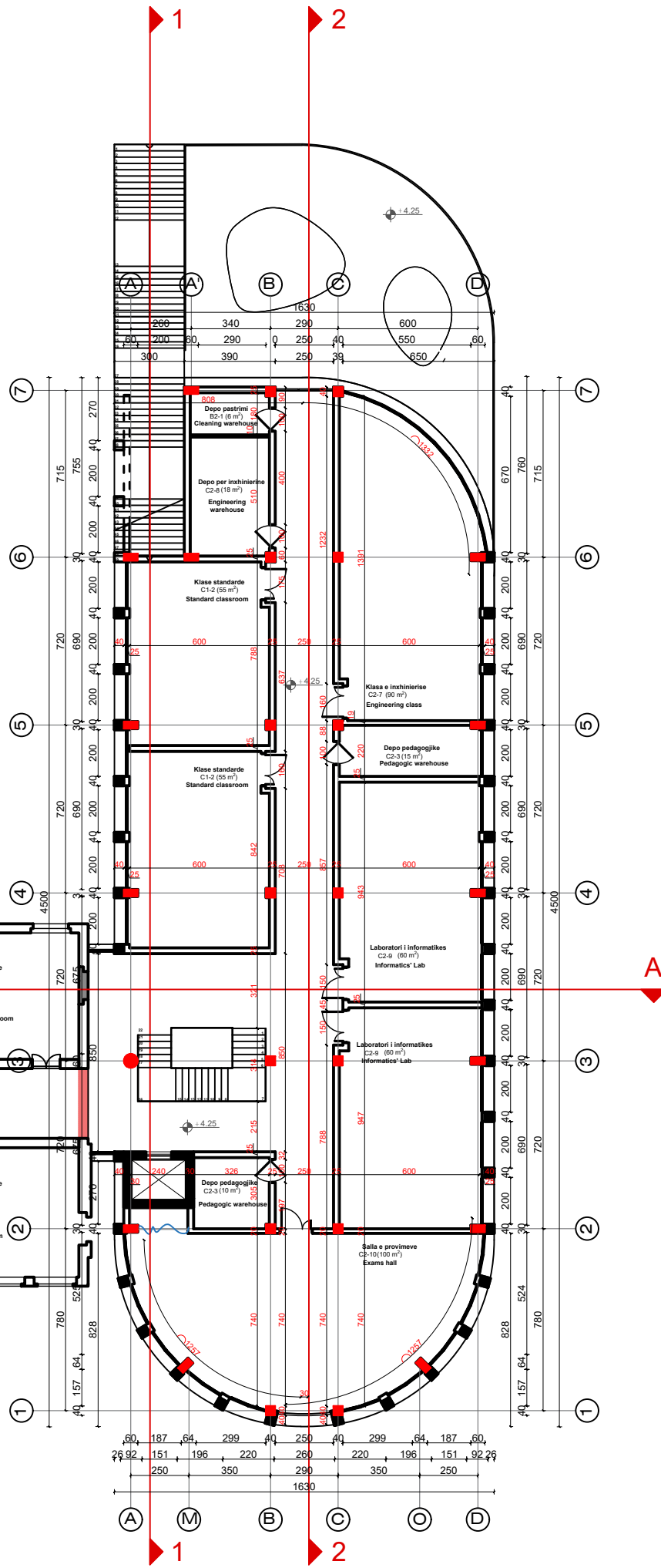
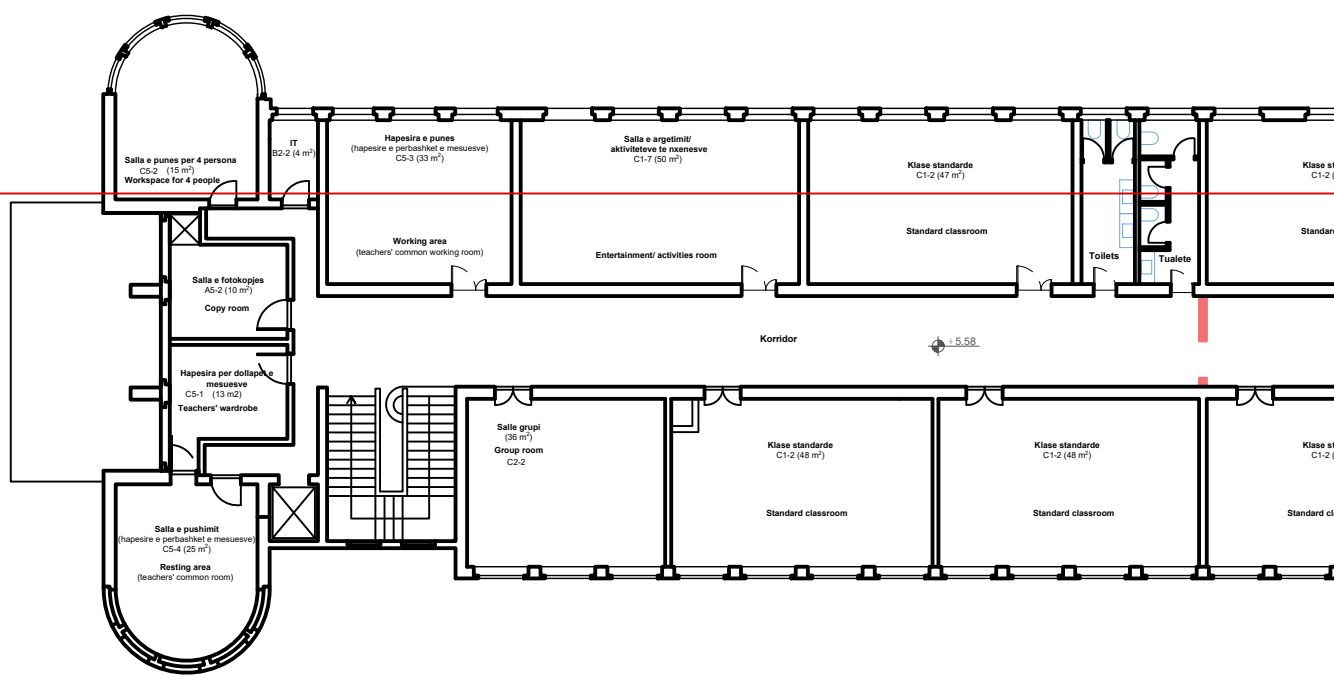

LEGJENDA/ Legenda:

SHENIME/ Notes:

PROJEKTI / Project:
Ngritja e Infrastrukturës Arsimore të Liceut Franko-Shqiptar të Shkencave dhe Inovacionit, Bashkia Korçë / Establishment of the Educational Infrastructure of the Franco-Albanian Lyceum of Sciences and Innovation, Municipality of Korça

Klienti: FONDI SHQIPTAR I ZHVILLIMIT
Client: ALBANIAN DEVELOPMENT FUND

IRI Local Architecture Office (LOC) Studio Lokale Arkitekture (VEND) Gent Agalli	N.6844	Firma / Signature: Lexoj dhe aprovoj / I read and approve.
ARCHISPACE Local Architecture Office (LOC) Studio Lokale Arkitekture (VEND) Rais Petrela	N.6732/14	Firma / Signature: Lexoj dhe aprovoj / I read and approve.
SPHAERA Local Architecture Office (LOC) Studio Lokale Arkitekture (VEND) Aldid Topore	N.4654/14	Firma / Signature: Lexoj dhe aprovoj / I read and approve.
LORENC BEGAJ AVE CONSULTING Construction Studio Studio Konstruksioni Ing. Arben Demushaj Ing. Ermal Spahiu Ing. Ina Hotaj	K.2138/2 N.5628/12	Firma / Signature: Lexoj dhe aprovoj / I read and approve.
BURHAN TURKESHI ERMIR GJOKA Hydro-Mechanical Engineering Inzhinieri Hidro-Mekanik dhe MNZ	K.1873/4 M.1174/2	Firma / Signature: Lexoj dhe aprovoj / I read and approve.
BASHKIM SHAHINAJ BESART DALLIU Electrical Engineering Inzhinieri Elektrik	E.0185/6 E.1412/2	Firma / Signature: Lexoj dhe aprovoj / I read and approve.

ALL DIMENSIONS HAVE TO BE VERIFIED BY THE CONTRACTOR ON THE CONSTRUCTION SITE				TË GJITHA DIMENSIONET DUHET TË VERIFIKOHEN NGA KONTRAKTORI NË VËND			
IMPORTANT: These drawings are property of IRI. Rruga DERVISH HIMA, nr 8 kati i pare - 1001 TIRANA. Copy, multiplication or distribution inbetween parties of these plans (or any part of it) without written permission of IRI is prohibited.				E RËNDËSISHME: Këto vizatime janë pronë e IRI, Rruga DERVISH HIMA, nr 8 kati i parë - 1001 TIRANË. Kopjimi, shumfishimi apo shpërndarja e këtyre vizatimeve (apo pjesëve të tyre) pa lejen me shkrim të IRI është e ndaluar.			
issuer A	plan number: A.00.1	TITULLI / Title: PLANI I KATIT +1 teknik _ Shkolla					
Faza: LN	data: 2026	shkalla e vizatimit: 1:250	formati: A3	N			