

# PROFILAT TERTHORE TIP SHK. 1:50

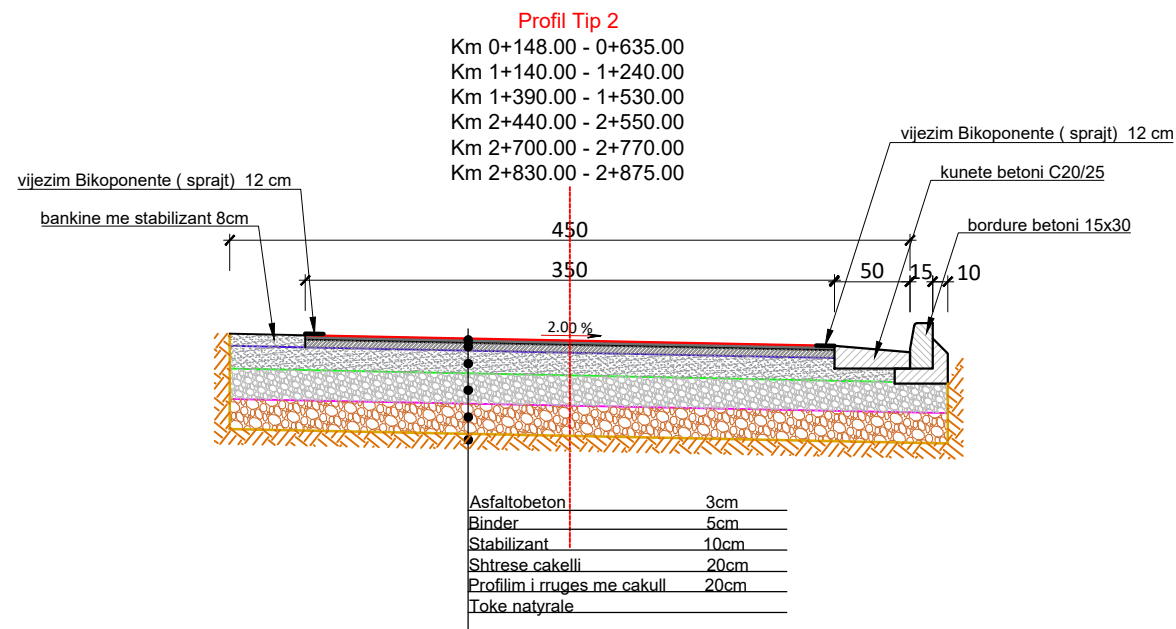
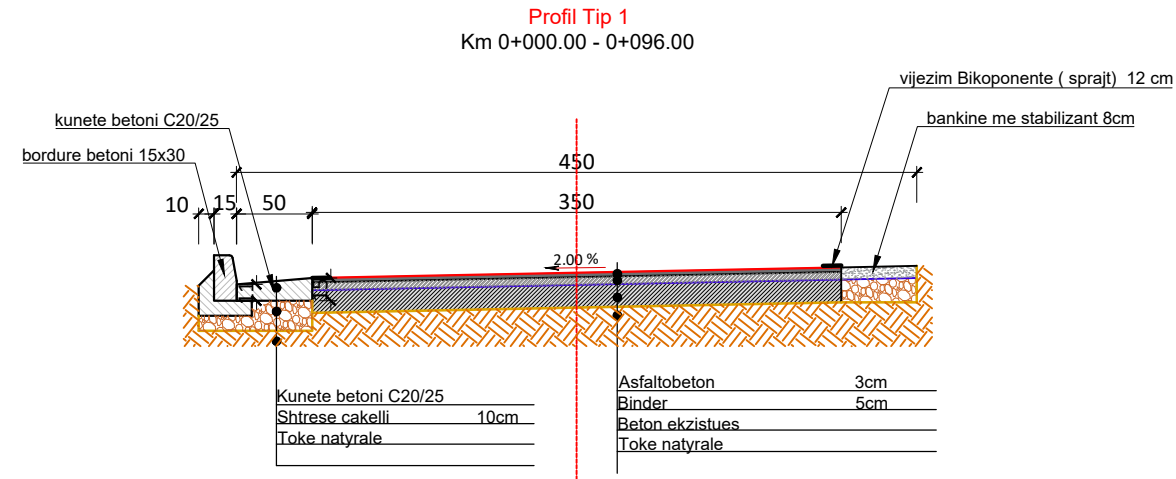

EMERTESA OBJEKTIT: "SISTEMIM ASFALTIM I RRUGES FSHATI SPATHARE" (Loti I), BASHKIA LIBRAZH

 REPUBLIKA E SHQIPERISE	FAZA E PROJEKTIT: PROJEKT ZBATIMI	Nr: 01	
	EMERTESA E FLETES: HOROGRAFIA E RRUGES		SH-1:50
 ZENIT&CO	POROSITESI - BASHKIA LIBRAZH		Dt: __/__/2023
	Rruga: Myrteza Topi (Nr 18, zip.code: 1007) E-Mail: zenit06@live.com TIRANE - ALBANIA		GRUPI PROJEKTIMIT (ZENIT & CO) Inxh. Hidro. Merita MENGRI      Inxh. Gjeo. Yzeir MIRAKA Inxh. Ndert. Rexhep Tarba      Inxh. Mek. Arqile PERI Inxh. Elek. Spiro PLEQI      Inxh. Gjeodet. Lulzim VRAPI Ark. Raimonda MYDINLLARI
		Mobile phone 069 20 99 065 Shoqeria "ZENIT&CO"	

# PROFILAT TERTHORE TIP SHK. 1:50

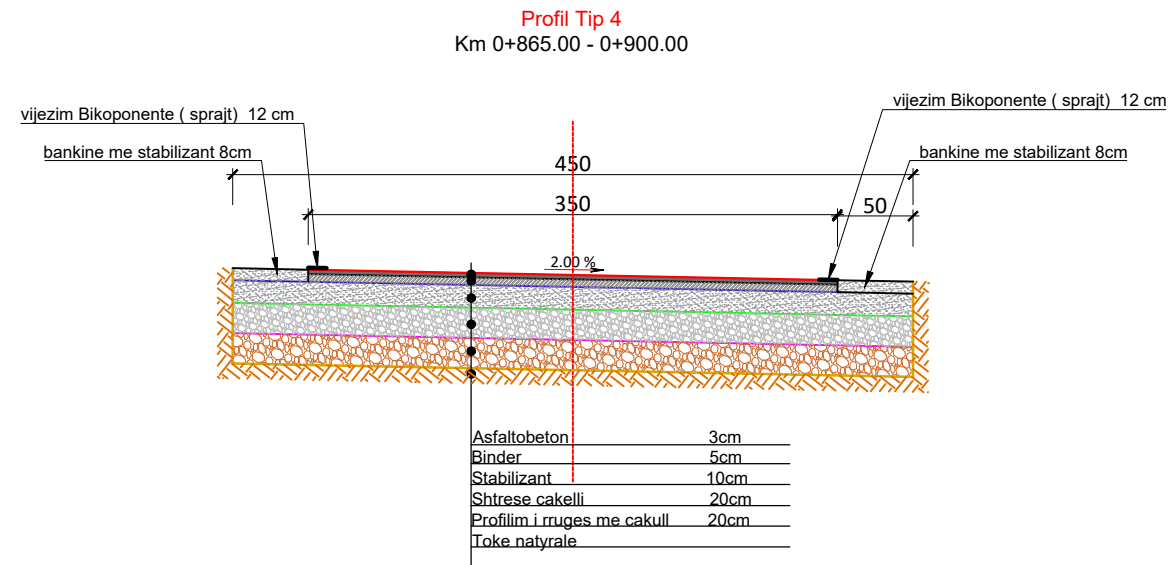
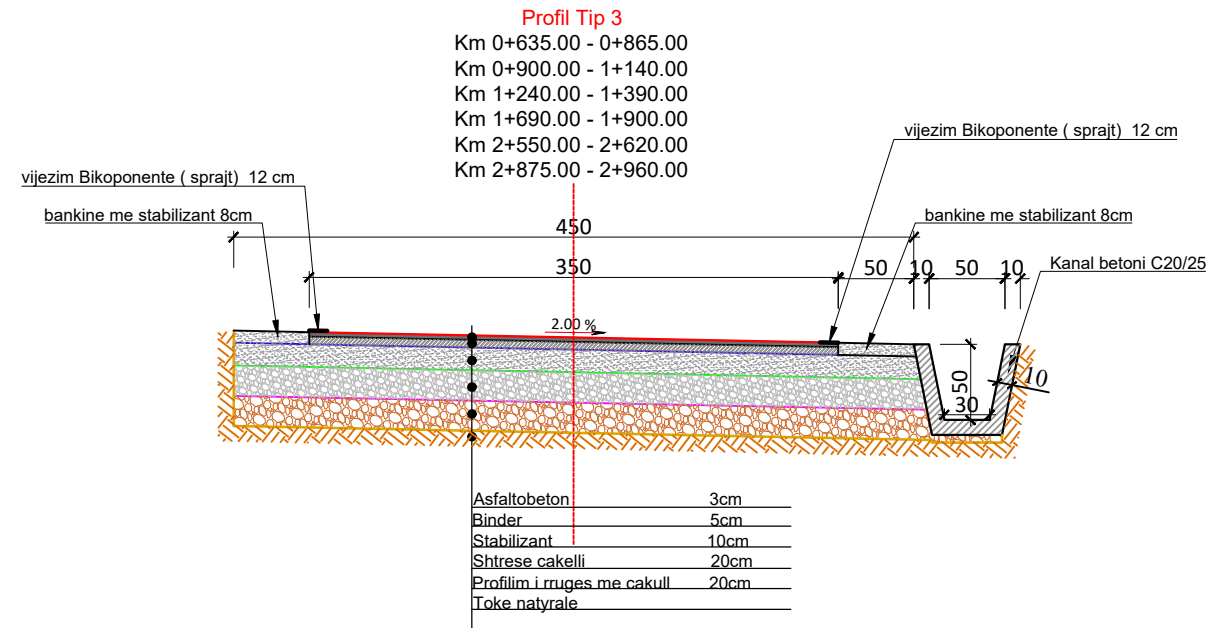

EMERTESA OBJEKTIT: "SISTEMIM ASFALTIM I RRUGES FSHATI SPATHARE" (Loti I), BASHKIA LIBRAZH

 REPUBLIKA E SHQIPERISE	<b>FAZA E PROJEKTIT: PROJEKT ZBATIMI</b>	Nr: 02	
	EMERTESA E FLETES: HOROGRAFIA E RRUGES		SH-1:50
 ZENIT&CO	<b>POROSITESI - BASHKIA LIBRAZH</b>		Dt: __/__/2023
	Rruga: Myrteza Topi (Nr 18.zip.code.1007)    E-Mail: zenit06@live.com TIRANE - ALBANIA		GRUPI PROJEKTIMIT (ZENIT & CO) Inxh. Hidro. Merita MENGRI    Inxh. Gjeo. Yzeir MIRAKA Inxh. Ndert. Rexhep Tarba    Inxh. Mek. Arqile PERI Inxh. Elek. Spiro PLEQI    Inxh. Gjeodet. Lulzim VRAPI Ark. Raimonda MYDINLLARI

Shoqeria  
"ZENIT&CO"

# PROFILAT TERTHORE TIP SHK. 1:50

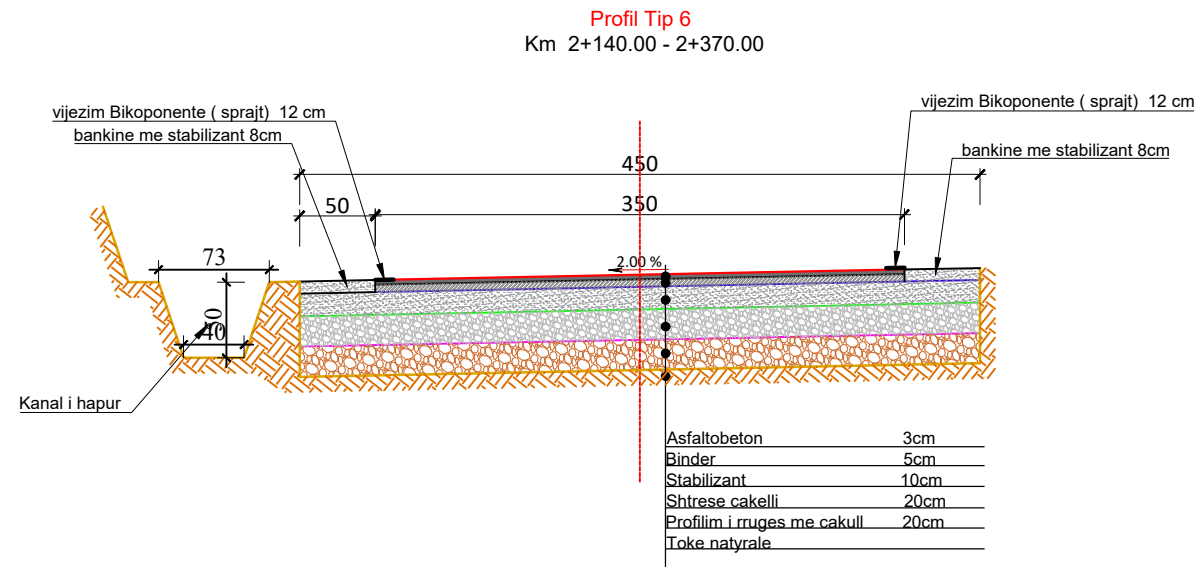
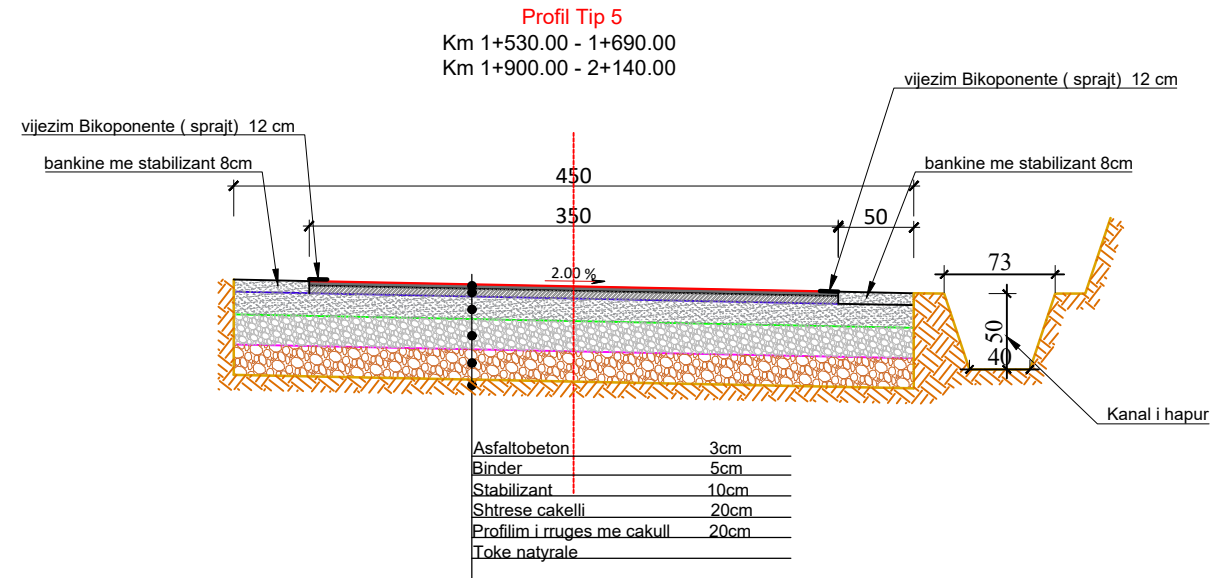

EMERTESA OBJEKTIT: "SISTEMIM ASFALTIM I RRUGES FSHATI SPATHARE" (Loti I), BASHKIA LIBRAZH

 REPUBLIKA E SHQIPERISE	FAZA E PROJEKTIT: PROJEKT ZBATIMI	Nr: 03	
	EMERTESA E FLETES: HOROGRAFIA E RRUGES		SH-1:50
 ZENIT&CO	POROSITESI - BASHKIA LIBRAZH		Dt: __/__/2023
	Rruga: Myrteza Topi (Nr 18, zip.code: 1007)    Mobile phone: 069 20 99 065 E-Mail: zenit06@live.com    TIRANE - ALBANIA		GRUPI PROJEKTIMIT (ZENIT & CO) Inxh. Hidro. Merita MENGRI    Inxh. Gjeo. Yzeir MIRAKA Inxh. Ndert. Rexhep Tarba    Inxh. Mek. Arqile PERI Inxh. Elek. Spiro PLEQI    Inxh. Gjeodet. Lulzim VRAPI Ark. Raimonda MYDINLLARI

Shoqeria  
"ZENIT&CO"

# PROFILAT TERTHORE TIP SHK. 1:50

**Profil Tip 7**  
 Km 2+370.00 - 2+440.00  
 Km 2+620.00 - 2+700.00  
 Km 3+040.00 - 3+250.00

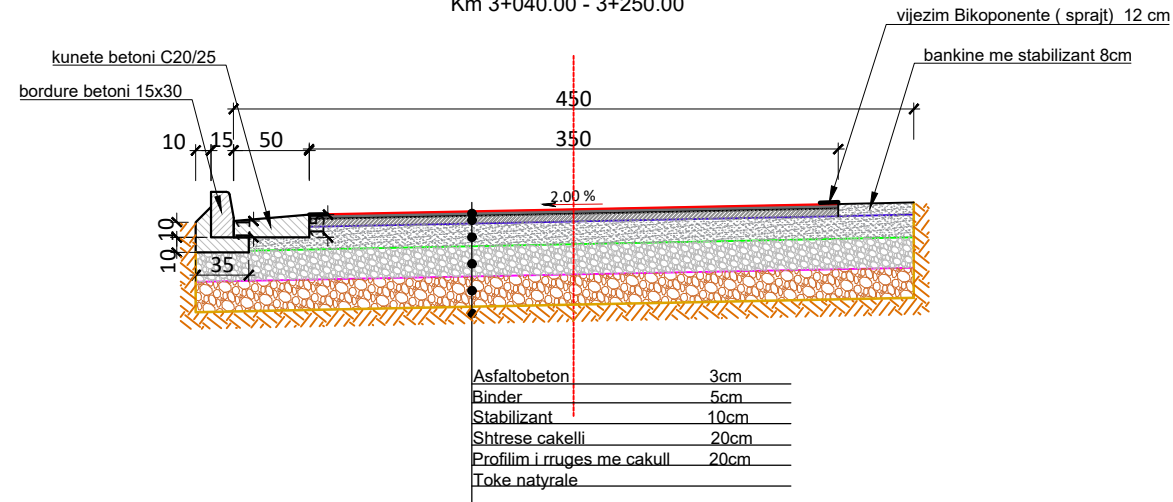

**Profil Tip 8**  
 Km 2+770.00 - 2+830.00  
 Km 2+960.00 - 3+040.00

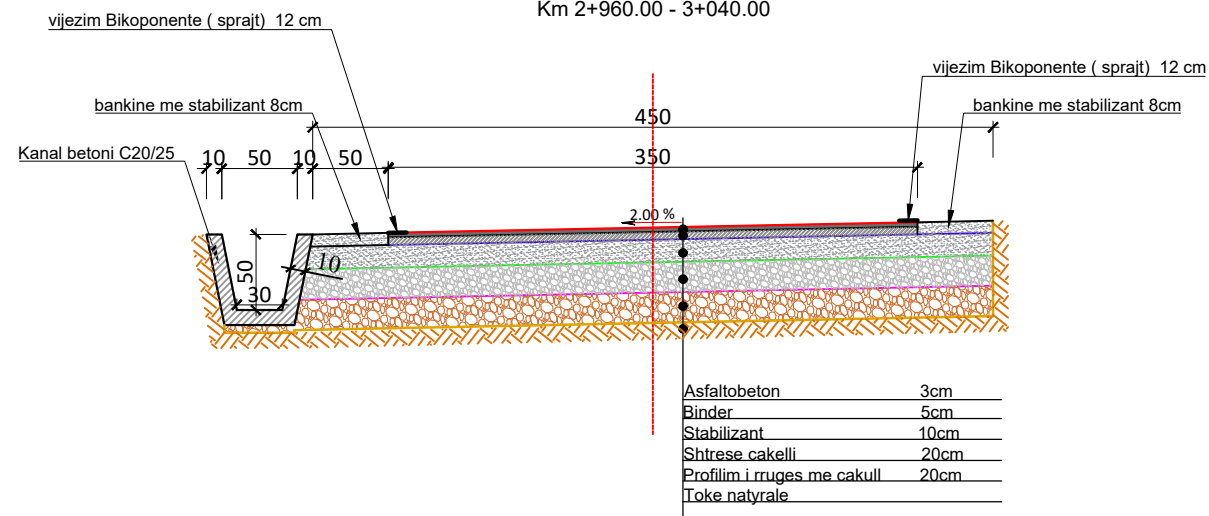

EMERTESA OBJEKTIT: "SISTEMIM ASFALTIM I RRUGES FSHATI SPATHARE" (Loti I), BASHKIA LIBRAZH

 REPUBLIKA E SHQIPERISE	FAZA E PROJEKTIT: PROJEKT ZBATIMI	Nr: 04	
	EMERTESA E FLETES: HOROGRAFIA E RRUGES		SH-1:50
 ZENIT&CO	POROSITESI - BASHKIA LIBRAZH		Dt: __/__/2023
	Rruga: Myrteza Topi (Nr 18.zip.code.1007) E-Mail: zenit06@live.com TIRANE - ALBANIA	Mobile phone 069 20 99 065	GRUPI PROJEKTIMIT (ZENIT & CO) Inxh. Hidro. Merita MENGRI Inxh. Ndert. Rexhep Tarba Inxh. Elek. Spiro PLEQI Ark. Raimonda MYDINLLARI

# PROFILAT TERTHORE TIP

## SHK. 1:50

Mur prites C20/25 h=2.0m  
Sh 1:50

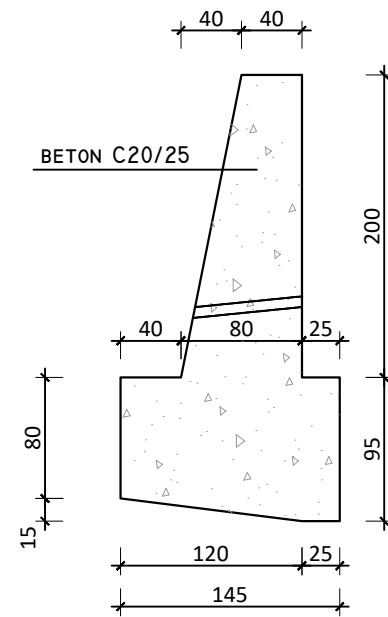

Mur prites C20/25 h=1.5m  
Sh 1:50

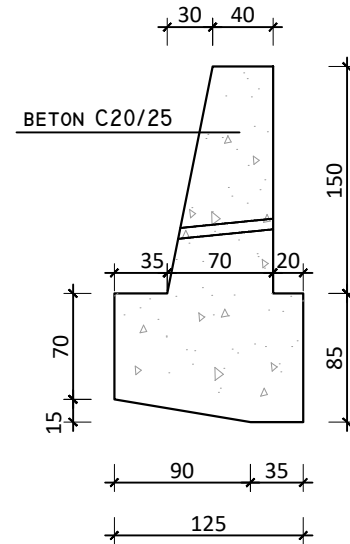

Mur prites C20/25 h=1.0m  
Sh 1:50

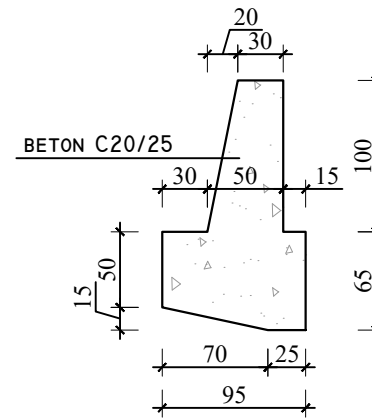

DETAJ I VENDOSJES SE MURIT NE TERREN  
SH.1:50

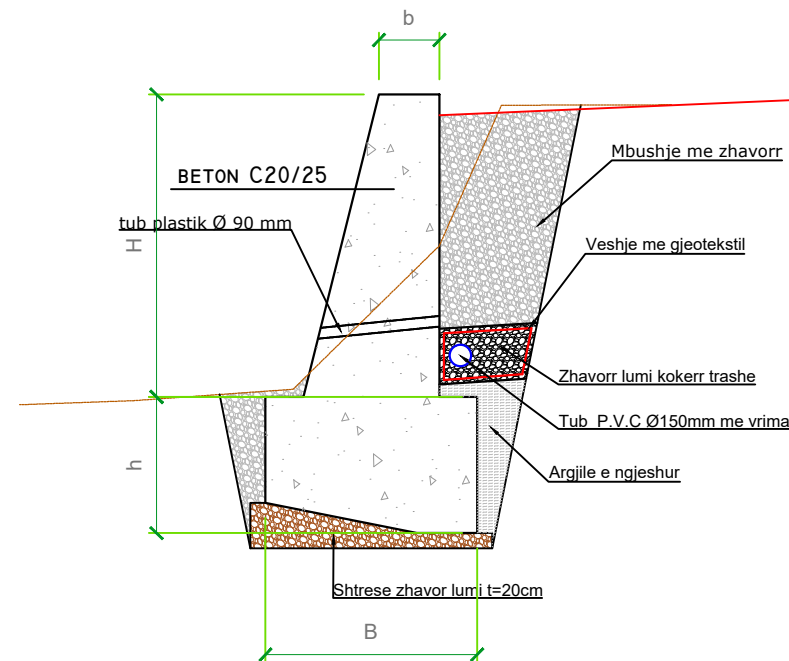

EMERTESA OBJEKTIT: "SISTEMIM ASFALTIM I RRUGES FSHATI SPATHARE" (Loti I), BASHKIA LIBRAZH

 REPUBLIKA E SHQIPERISE	FAZA E PROJEKTIT: PROJEKT ZBATIMI	Nr: 05
	EMERTESA E FLETES: HOROGRAFIA E RRUGES	SH-1:50
 ZENIT&CO	POROSITESI - BASHKIA LIBRAZH	Dt. __/__/2023
	Rruga: Myrteza Topi (Nr 18.zip.code.1007) Mobile phone 069 20 99 065 E-Mail: zenit06@live.com TIRANE - ALBANIA	GRUPI PROJEKTIMIT (ZENIT & CO) Inxh. Hidro. Merita MENGRI Inxh. Gjeo. Yzeir MIRAKA Inxh. Ndert. Rexhep Tarba Inxh. Mek. Arqile PERI Inxh. Elek. Spiro PLEQI Inxh. Gjeodet. Luizim VRAPI Ark. Raimonda MYDINLLARI