

**BURIMI Nr.1**  
Dunicë  
1106 m.m.n.d

**Depo Kryesore**  
1095 m.m.n.d

**Pusete "Y" Bashkimi i prurjes**

**Burimi Nr.1 - Depo Kryesore**

**VIJA E TOKES**  
**VIJA E PROJEKTI**

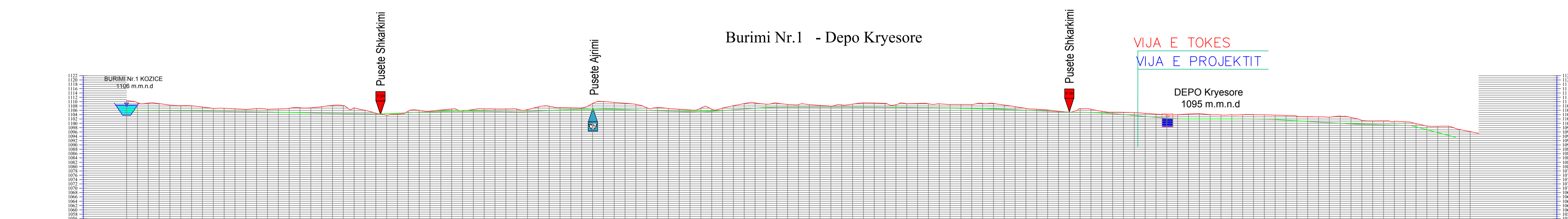

NUMRI PIKETES	1	2	3	4	5	6	7	8	9	10	11	12	13	14	15	16	17	18	19	20	21	22	23	24	25	26	27	28	29	30	31	32	33	
DISTANCA PROGRESIVE	0.0	4.0	8.0	12.0	16.0	20.0	24.0	28.0	32.0	36.0	40.0	44.0	48.0	52.0	56.0	60.0	64.0	68.0	72.0	76.0	80.0	84.0	88.0	92.0	96.0	100.0	104.0	108.0	112.0	116.0	120.0	124.0	128.0	132.0
ELEMENTET HIDRAULIK	<p>Q=10.00 l/s, H=6.043 m D=140 PE-RC V=1.226 m/s L=470 m</p> <p>Q=10.00 l/s, H=6.043 m D=140 PE-RC V=1.226 m/s L=470 m</p> <p>Q=10.00 l/s, H=6.043 m D=140 PE-RC V=1.226 m/s L=470 m</p> <p>Q=10.00 l/s, H=2.226 m D=140 PE-RC V=1.226 m/s L=170 m</p>																																	

**Investitor :**  
**BASHKIA POGRADEC**  
Adresa:  
Bulevardi "Reshit Collaku"  
Pogradec - Shqipëri  
Web: www.bashkiapogradec.al  
Email: bashkiapogradec@gmail.com



**Objekti:** "NDËRTIM UJESJELLËSI  
RAJONAL TREBINJË - BURIMET  
E KOZICËS"

Numri i projektit: **AL\_PG\_N\_U\_R\_T-B\_K**  
Vendodhja e projektit: **POGRADEC**

Grupi teknik i projektimit:  
**"ERALD-G" shpk Nr.lic. N- 5304/11**

Rruga "KONGRESI I LUSHNYES"  
Tirane  
eraldgshpk@yahoo.com  
Tel +355 4 357 970  
Cel +355 682090392

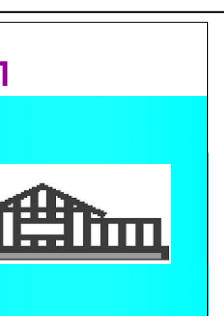

Administrator:  
**Gëzim ISLAMI**

Inxhinier Konstruktor:  
**Gëzim ISLAMI** Lic. K-1196/6

Inxhinier Hidroteknik:  
**Ersida VERCANI** Lic. K-1807/2

Arkitekt:  
**Elton CARCANI** Lic. A-0733/3

Inxhinier Elektrik:  
**Hajdar KURTI** Lic. E-0180/5

Inxhinier Topograf:  
**Kujtim CANAMETI** Lic. T-1058/3

Inxhinier Mekanik:  
**Arben MUHA** Lic. M-0308/3

Inxhinier Gjeolog:  
**Leonard KAZANXHIU** Lic. GJ-0556/3

Inxhinier Infrastruktura:  
**Gëzim ISLAMI** Lic. K-1196/6

Inxhinier Teknolog:  
**Ylber CANI**  
Inxhinier Mjedisit:  
**Nensi MEHMETI**

Emërtimi i fletës:  
**PROFILI GJATESOR  
BURIMI I KOZICES - DEPO KRYESORE**

Faza e projektit:  
**Projekt Zbatimi**

Formati: **A1**  
Shkalla: **SHV 1:100,  
SHH 1:1000**

Nr i fletes: **P.GJ.01**

Data:  
**2020**

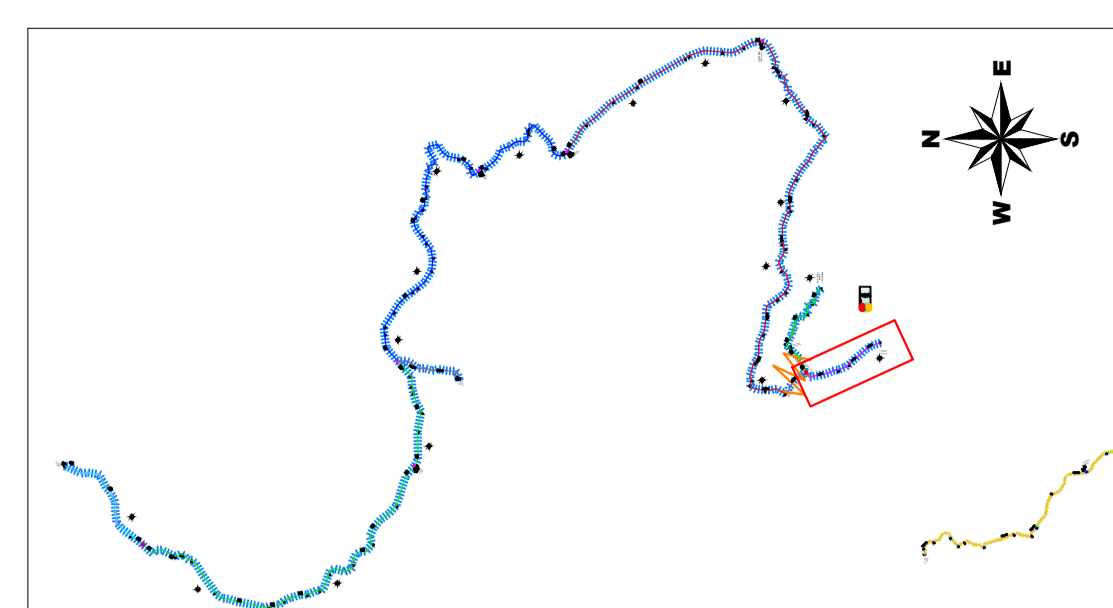
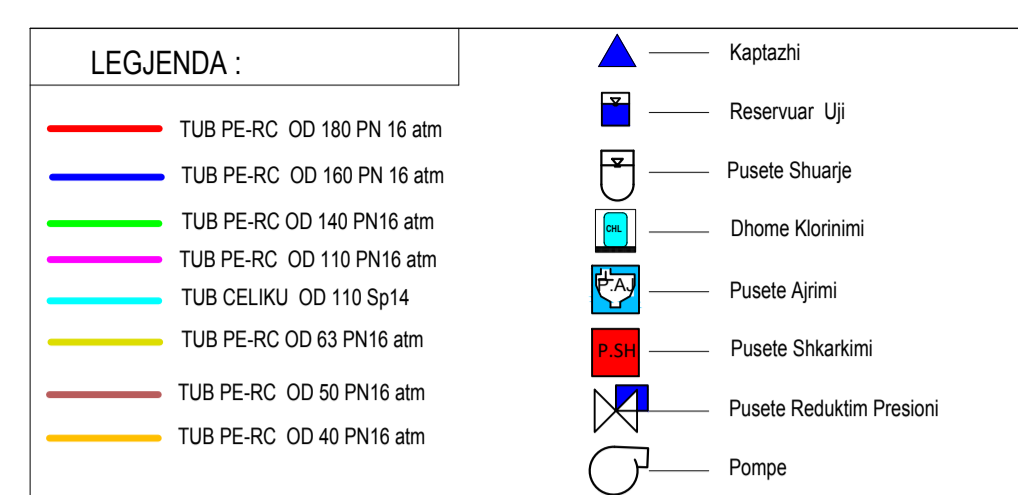
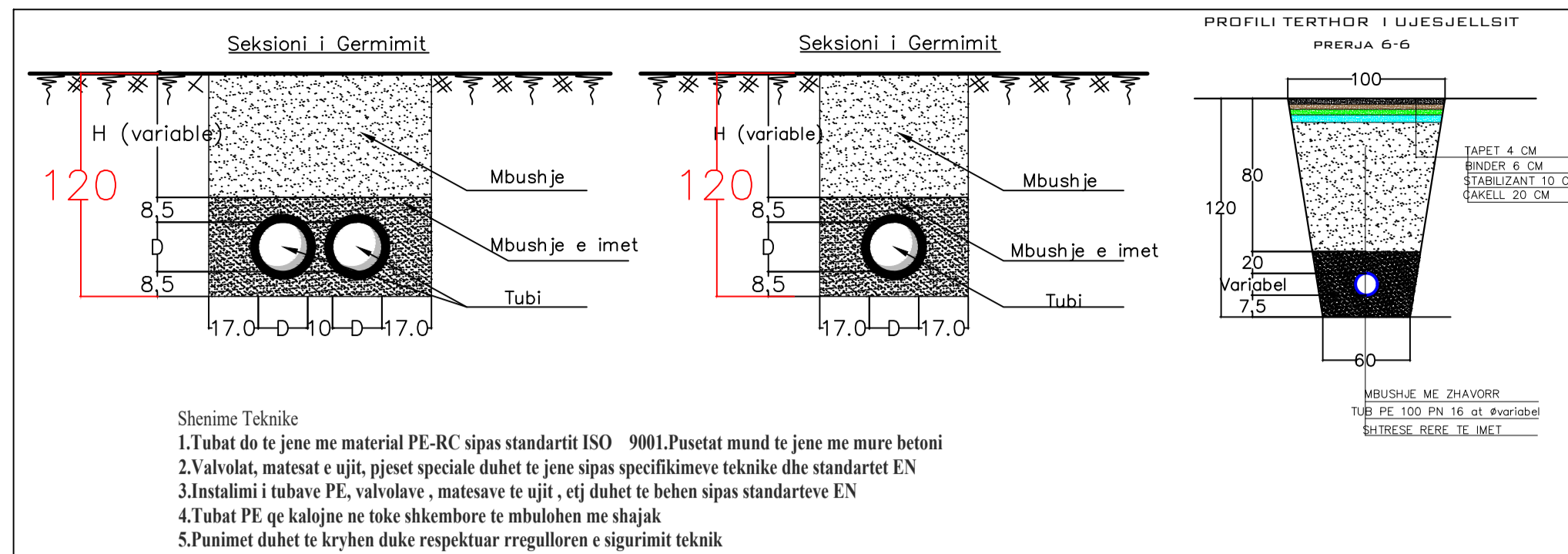

**Shenime Teknike**

- 1.Tubat do te jene me material PE-RC sipas standartit ISO 9001.Pusetat mund te jene me mure betoni
- 2.Valvolat, matesat e ujit, pjeset speciale duhet te jene sipas specifikimeve teknike dhe standartet EN
- 3.Instalimi i tubave PE, valvolave , matesave te ujit , etj duhet te behen sipas standarteve EN
- 4.Tubat PE qe kalojne ne toke shkemboore te mbulohen me shajak
- 5.Punimet duhet te kryhen duke respektuar rregulloren e sigurimit teknik

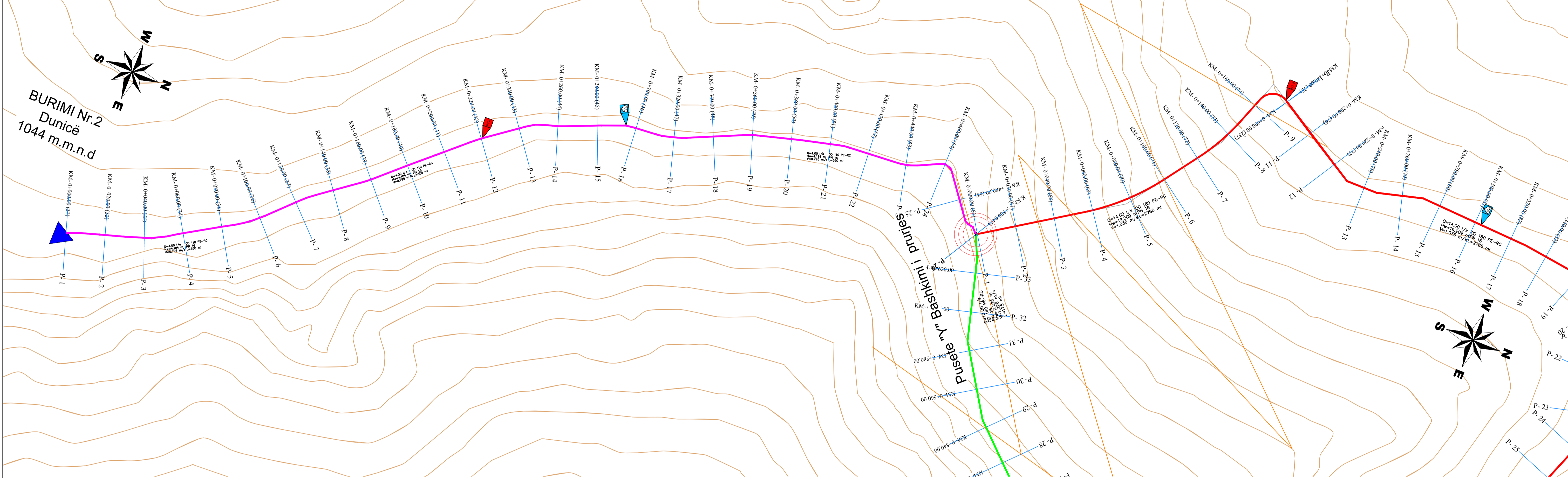

Burimi Nr.2 - Linje Transmetimi

**VIJA E TOKES**  
**VIJA E PROJEKTT**

BURIMI Nr.2 Dunicë 1044 m.m.n.d

NUMRI PIKETES	1	2	3	4	5	6	7	8	9	10	11	12	13	14	15	16	17	18	19	20	21	22	23	24	25	26	27	28	29	
DISTANCA PROGRESIVE	0.0	7.4	10.3	17.8	21.5	27.2	32.9	38.6	44.3	50.0	55.7	61.4	67.1	72.8	78.5	84.2	89.9	95.6	101.3	107.0	112.7	118.4	124.1	129.8	135.5	141.2	146.9	152.6	158.3	
ELEMENTET HIDRAULIK	Ø140/14, OD 10 PE-RC V=1.50 m/s, C=100 m										Ø140/14, OD 10 PE-RC V=1.50 m/s, C=100 m										Ø140/14, OD 10 PE-RC V=1.50 m/s, C=100 m									

**Investitor :**  
**BASHKIA POGRADEC**  
Adresa:  
Bulevardi "Reshit Collaku"  
Pogradec - Shqipëri  
Web: www.bashkiapogradec.al  
Email:bashkiapogradec@gmail.com



**Objekti: "NDËRTIM UJËSJELLËSI RAJONAL TREBINJË - BURIMET E KOZICËS"**

Numri i projektit: **AL\_PG\_N\_U\_R\_T-B\_K**  
Vendodhja e projektit: **POGRADEC**

Grupi teknik i projektimit:  
**"ERALD-G" shpk Nr.lic. N- 5304/11**

Rruga "KONGRESI I LUSHNYES"  
Tirane  
eraldgshpk@yahoo.com  
Tel +355 4 357 970  
Cel +355 682090392



Administrator:  
**Gëzim ISLAMI**  
Inxhinier Konstruktor:  
**Gëzim ISLAMI** Lic. K-1196/6  
Inxhinier Hidroteknik:  
**Ersida VERCANI** Lic. K-1807/2

Arkitekt:  
**Elton CARCANI** Lic. A-0733/3  
Inxhinier Elektrik:  
**Hajdar KURTI** Lic. E-0180/5  
Inxhinier Topograf:  
**Kujtim CANAMETI** Lic. T-1058/3

Inxhinier Mekanik:  
**Arben MUHA** Lic. M-0308/3  
Inxhinier Gjeolog:  
**Leonard KAZANXHIU** Lic. GJ-0556/3  
Inxhinier Infrastrukturate:  
**Gëzim ISLAMI** Lic. K-1196/6

Inxhinier Teknolog:  
**Ylber CANI**  
Inxhinier Mjedisit:  
**Nensi MEHMETI**  
Emërtimi i fletës:  
**PROFILI GJATESOR BURIMI NR.2 - LINJE TRANSMETIMI**

Faza e projektit:  
**Projekt Zbatimi**  
Formati: **A1**  
Shkalla: **SHV 1:100, SHH 1:1000**  
Nr i fletes: **P.GJ.02**  
Data: **2020**



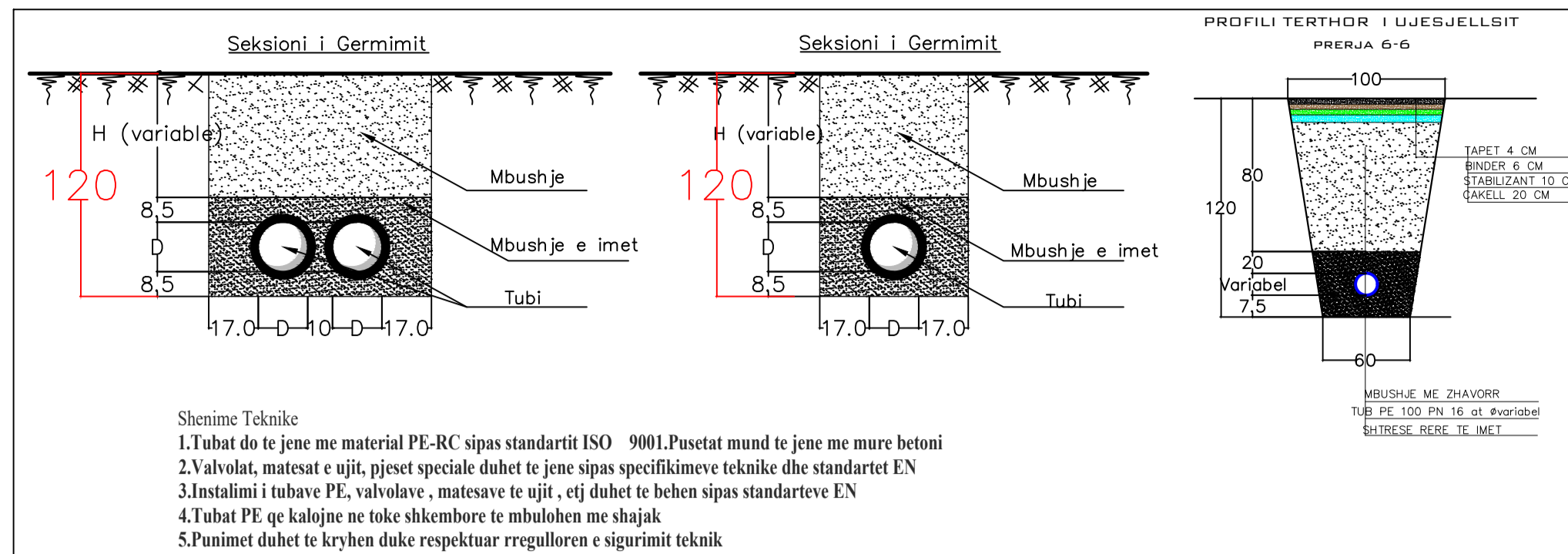

**LEGJENDA :**

- TUB PE-RC OD 180 PN 16 atm
- TUB PE-RC OD 160 PN 16 atm
- TUB PE-RC OD 140 PN16 atm
- TUB PE-RC OD 110 PN16 atm
- TUB CELIKU OD 110 Sp14
- TUB PE-RC OD 63 PN16 atm
- TUB PE-RC OD 50 PN16 atm
- TUB PE-RC OD 40 PN16 atm

- Kapazi
- Reservuar Uji
- Pusete Shuarje
- Dhomete Klorinimi
- Pusete Ajrimi
- Pusete Shkarkimi
- Pusete Reduktim Presioni
- Pompe

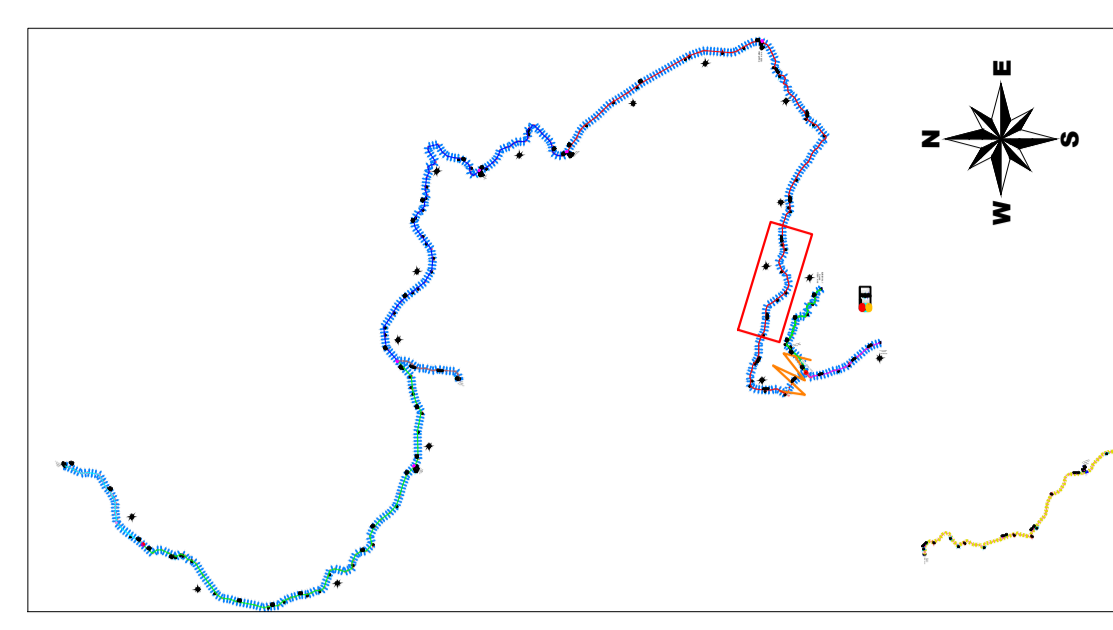

**Shenime Teknike**

- 1.Tubat do te jene me material PE-RC sipas standartit ISO 9001.Pusetat mund te jene me mure betoni
- 2.Valvolat, matesat e ujit ,pjeset speciale duhet te jene sipas specifikimeve teknike dhe standartet EN
- 3.Instalimi i tubave PE, valvolave , matesave te ujit , eji duhet te behen sipas standarteve EN
- 4.Tubat PE qe kalojne ne toke shkemboare te mbulohe me shajak
- 5.Punimet duhet te kryhen duke respektuar rregulloren e sigurimit teknik

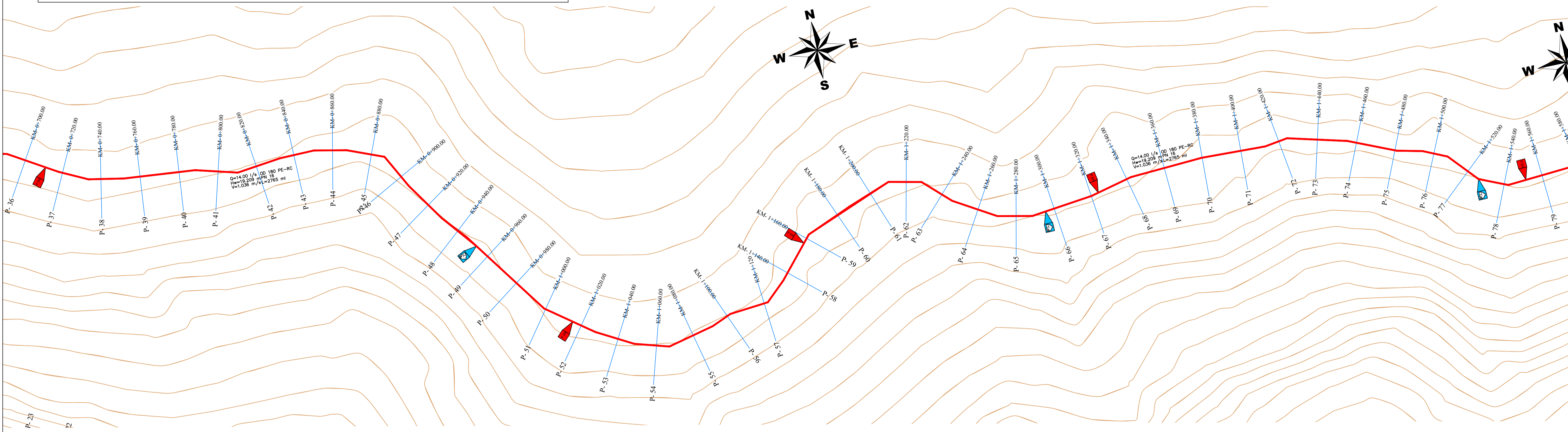

Depo Kryesore - Depo Kalivac

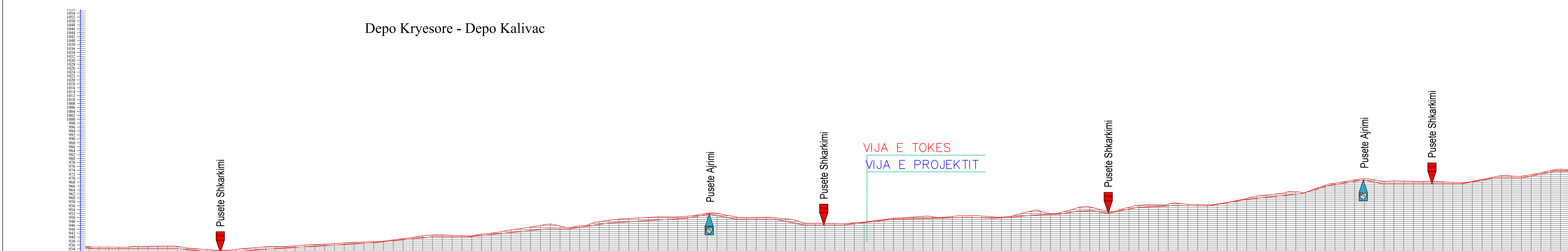

NUMRI PIKETES	37	38	39	40	41	42	43	44	45	46	47	48	49	50	51	52	53	54	55	56	57	58	59	60	61	62	63	64	65	66	67	68	69	70	71	72	73	74
DISTANCA PARCIALE	15.5	13.9	15.6	27.0	15.3	17.5	23.8	24.0	20.9	22.1	17.3	16.1	18.2	18.0	13.8	9.4	22.5	15.5	26.2	30.7	28.0	20.3	16.8	23.3	10.2	18.5	12.4	25.9	46.9	15.1	17.1	23.4	16.8	31.2	22.0	144.4	145.8	
DISTANCA PROGRESIVE	714.4	730.3	746.2	773.2	788.5	806.0	829.8	853.8	874.7	895.6	912.9	929.0	947.2	966.0	985.4	1004.9	1027.4	1042.9	1069.1	1099.8	1127.8	1152.8	1179.6	1200.1	1228.6	1247.1	1273.0	1308.9	1355.8	1372.9	1396.3	1414.7	1431.5	1462.9	1607.3	1752.1	1897.9	

**Investitor :**  
**BASHKIA POGRADEC**  
Adresa:  
Bulevardi "Reshit Collaku"  
Pogradec - Shqipëri  
Web: www.bashkiapogradec.al  
Email:bashkiapogradec@gmail.com



**Objekti: "NDËRTIM UJËSJELLËSI RAJONAL TREBINJË - BURIMET E KOZICËS"**

Numri i projektit: **AL\_PG\_N\_U\_R\_T-B\_K**  
Vendodhja e projektit: **POGRADEC**

Grupi teknik i projektimit:  
**"ERALD-G" shpk Nr .Iic. N- 5304/11**

Rruga "KONGRESI I LUSHNYES"  
Tirane  
eraldgshpk@yahoo.com  
Tel +355 4 357 970  
Cel +355 682090392

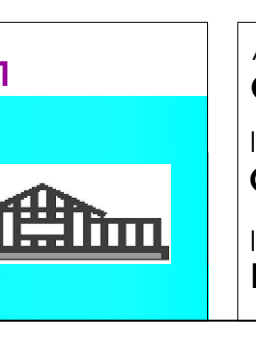

Administrator:  
**Gëzim ISLAMI**

Inxhinier Konstruktor:  
**Gëzim ISLAMI** Lic. K-1196/6

Inxhinier Hidroteknik:  
**Ersida VERCANI** Lic. K-1807/2

Arkitekt:  
**Elton CARCANI** Lic. A-0733/3

Inxhinier Elektrik:  
**Hajdar KURTI** Lic. E-0180/5

Inxhinier Topograf:  
**Kujtim CANAMETI** Lic. T-1058/3

Inxhinier Mekanik:  
**Arben MUHA** Lic. M-0308/3

Inxhinier Gjeolog:  
**Leonard KAZANXHIU** Lic. GJ-0556/3

Inxhinier Infrastrukturate:  
**Gëzim ISLAMI** Lic. K-1196/6

Inxhinier Teknolog:  
**Ylber CANI**  
Inxhinier Mjedisit:  
**Nensi MEHMETI**

Emërtimi i fletës:  
**PROFILI GJATESOR DEPO KRYESORE - DEPO KALIVAC**

Faza e projektit:  
**Projekt Zbatimi**

Formati: **A1**  
Shkalla: **SHV 1:100, SHH 1:1000**

Nr i fletes: **P.GJ.04**

Data:  
**2020**

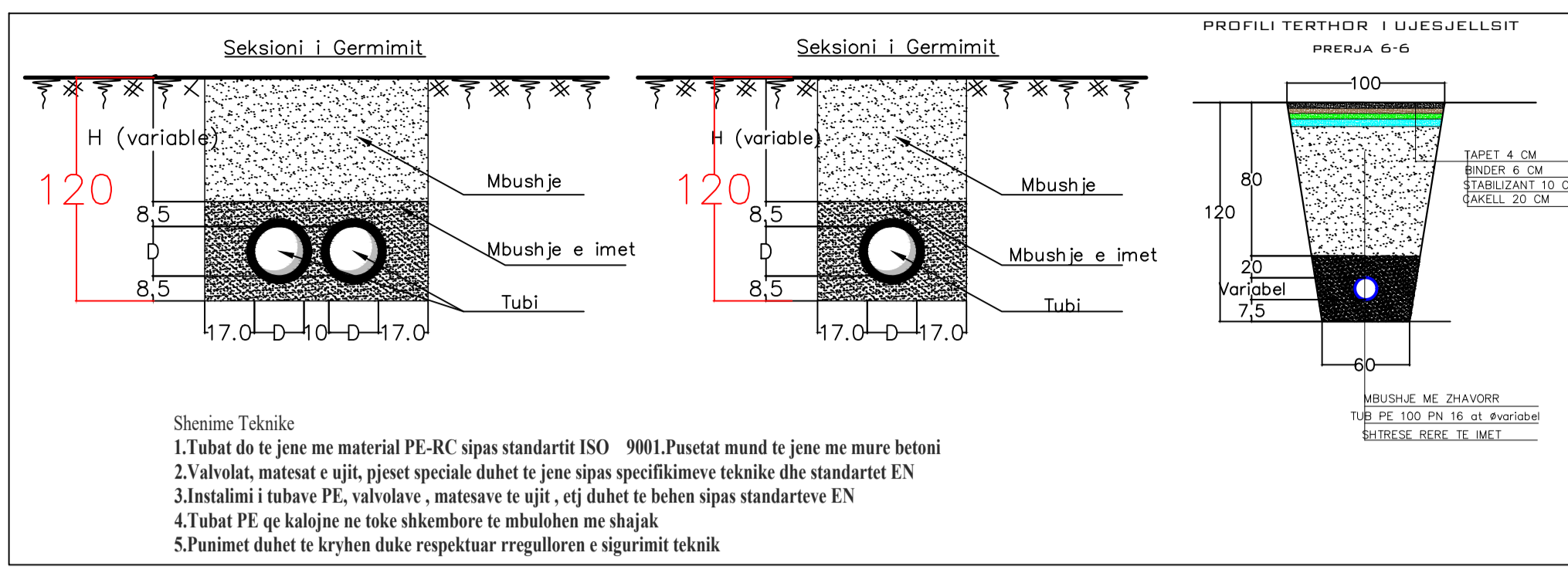

**LEGJENDA :**

- TUB PE-RC OD 180 PN 16 atm
- TUB PE-RC OD 160 PN 16 atm
- TUB PE-RC OD 140 PN16 atm
- TUB PE-RC OD 110 PN16 atm
- TUB CELIKU OD 110 Sp14
- TUB PE-RC OD 63 PN16 atm
- TUB PE-RC OD 50 PN16 atm
- TUB PE-RC OD 40 PN16 atm

- Kapazi
- Reservuar Uji
- Pusete Shuarje
- Dhome Klorinimi
- Pusete Ajtimi
- Pusete Shkarkimi
- Pusete Reduktim Presioni
- Pompe

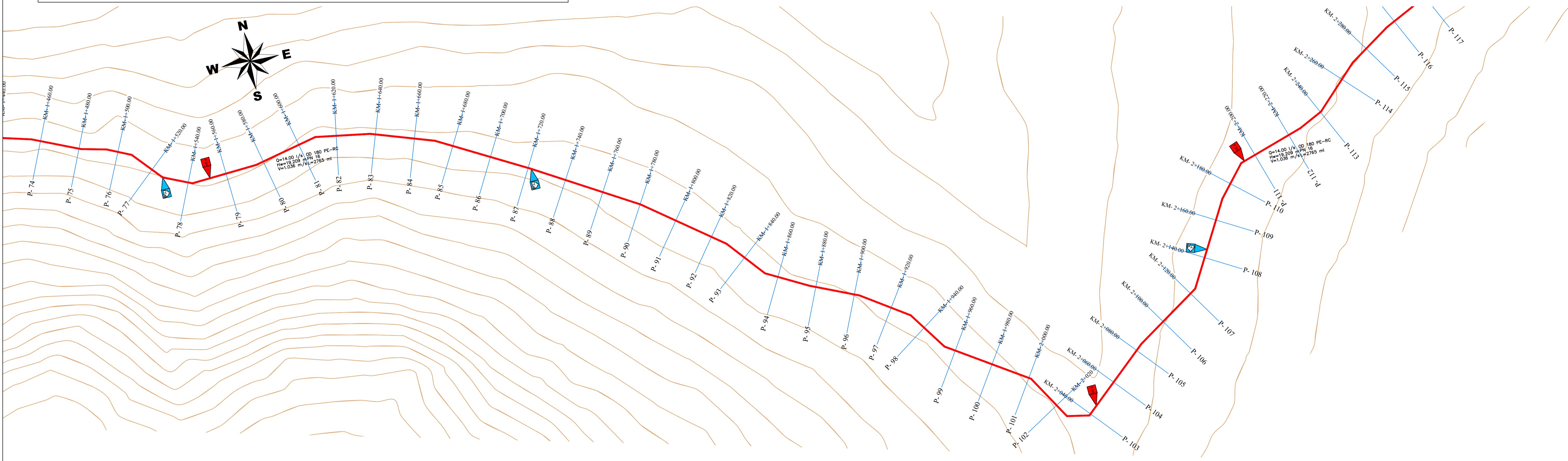
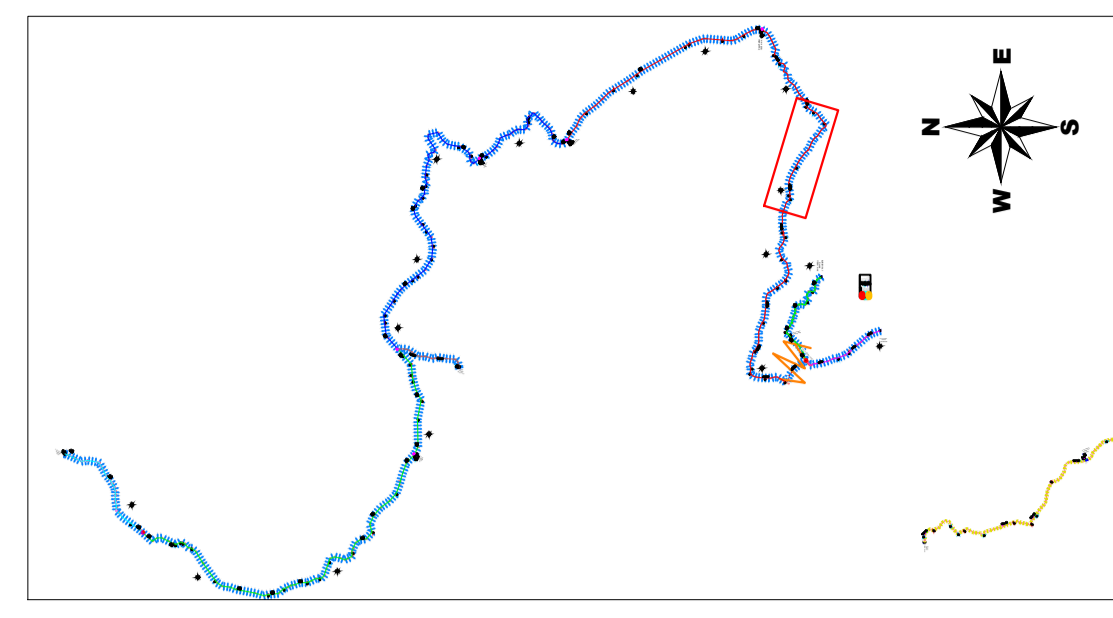

Depo Kryesore - Depo Kalivac

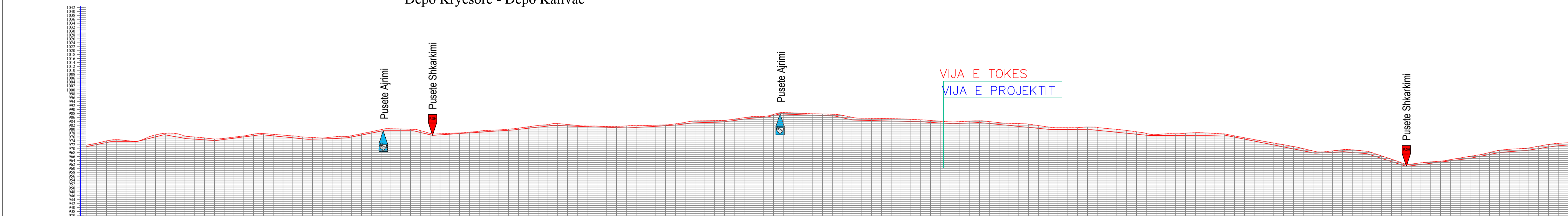

NUMRI PIKETES	74	75	76	77	78	79	80	81	82	83	84	85	86	87	88	89	90	91	92	93	94	95	96	97	98	99	100	101	102	103	104	105	106	107	108	109	110	111		
DISTANCA PARCIALE	0	32.3	11.0	30.0	25.1	12.7	12.1	18.2	14.1	32.8	14.8	32.5	27.3	32.6	176.0	174.0	50.8	278.5	58.4	183.3	40.1	74.8	23.7	22.7	348.8	25.9	1974.6	27.0	22.2	45.9	24.3	8.6	43.5	38.2	111.8					
DISTANCA PROGRESIVE	1452.8	1485.1	1506.1	1536.1	1561.2	1573.9	1586.0	1604.2	1618.3	1651.1	1665.9	1698.4	1725.7	1758.3	1934.3	2108.3	2159.1	2437.6	2496.0	2679.4	2753.2	2828.0	2851.7	2875.4	3224.2	3250.1	3447.7	3474.7	3506.9	3531.2	3549.8	3593.3	3636.8	3680.3	3723.8	3767.3	3810.8	3854.3		
ELEMENTET HIDRAULIK																																								

**Investitor :**  
**BASHKIA POGRADEC**  
Adresa:  
Bulevardi "Rreshit Collaku"  
Pogradec - Shqipëri  
Web: www.bashkiapogradec.al  
Email: bashkiapogradec@gmail.com



**Objekti:** "NDËRTIM UJËSJELLËSI RAJONAL TREBINJË - BURIMET E KOZICËS"  
Numri i projektit: **AL\_PG\_N\_U\_R\_T-B\_K**  
Vendodhja e projektit: **POGRADEC**

Grupi teknik i projektimit:  
**"ERALD-G" shpk Nr. Lic. N- 5304/11**  
Rruga "KONGRESI I LUSHNYES"  
Tirane  
eraldgshpk@yahoo.com  
Tel +355 4 357 970  
Cel +355 682090392

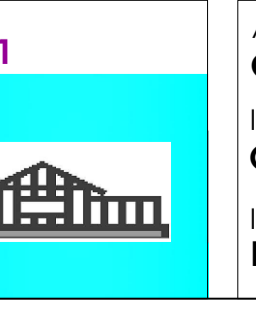

Administrator:  
**Gëzim ISLAMI**  
Inxhinier Konstruktor:  
**Gëzim ISLAMI** Lic. K-1196/6  
Inxhinier Hidroteknik:  
**Ersida VERCANI** Lic. K-1807/2

Arkitekt:  
**Elton CARCANI** Lic. A-0733/3  
Inxhinier Elektrik:  
**Hajdar KURTI** Lic. E-0180/5  
Inxhinier Topograf:  
**Kujtim CANAMETI** Lic. T-1058/3

Inxhinier Mekanik:  
**Arben MUHA** Lic. M-0308/3  
Inxhinier Gjeolog:  
**Leonard KAZANXHIU** Lic. GJ-0556/3  
Inxhinier Infrastrukturate:  
**Gëzim ISLAMI** Lic. K-1196/6

Inxhinier Teknolog:  
**Ylber CANI**  
Inxhinier Vijeçdis:  
**Nensi MEHMETI**  
Emërtimi i fletës:  
**PROFILI GJATESOR DEPO KRYESORE - DEPO KALIVAC**

Faza e projektit:  
**Projekt Zbatimi**  
Formati: **A1**  
Shkalla: **SHV 1:100, SHH 1:1000**  
Nr i fletes: **P.GJ.05**  
Data: **2020**









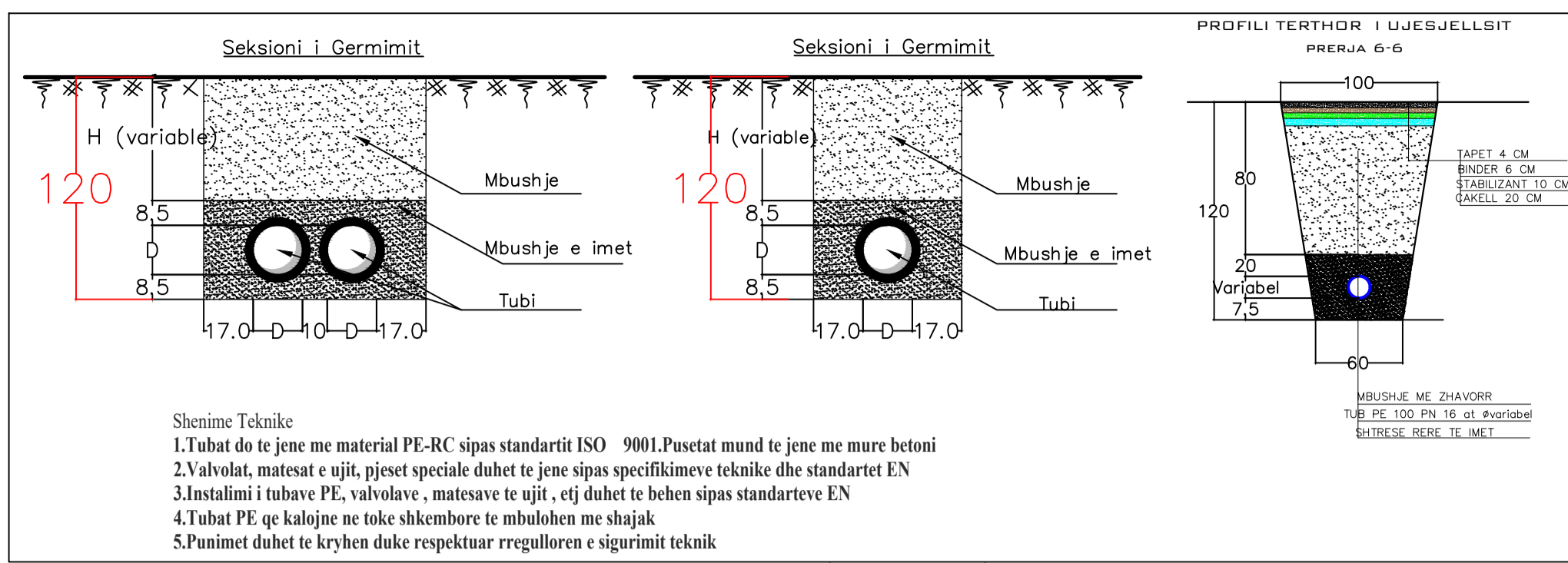

**LEGJENDA :**

	Kapdazi
	Reservuar Uji
	Pusete Shuarje
	Dhome Klorinimi
	Pusete Ajrimi
	Pusete Shkarkimi
	Pusete Reduktim Presioni
	Pompe

TUB PE-RC OD 180 PN 16 atm  
 TUB PE-RC OD 160 PN 16 atm  
 TUB PE-RC OD 140 PN16 atm  
 TUB PE-RC OD 110 PN16 atm  
 TUB CELIKU OD 110 Sp14  
 TUB PE-RC OD 63 PN16 atm  
 TUB PE-RC OD 50 PN16 atm  
 TUB PE-RC OD 40 PN16 atm

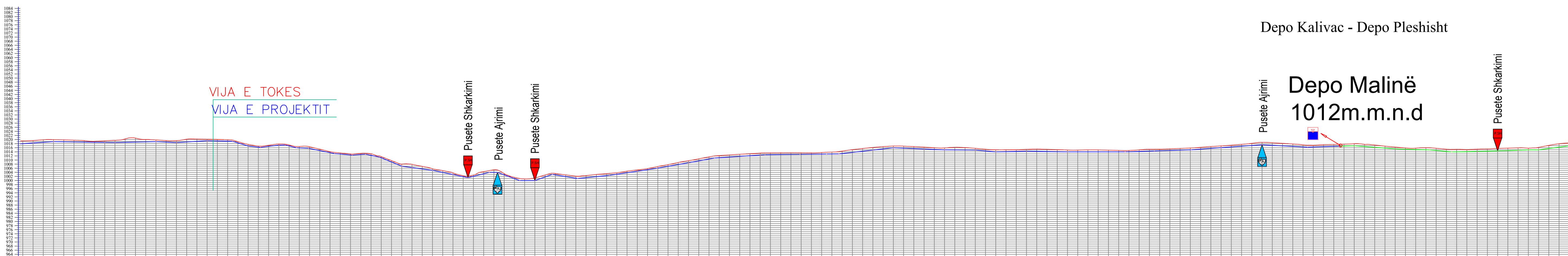
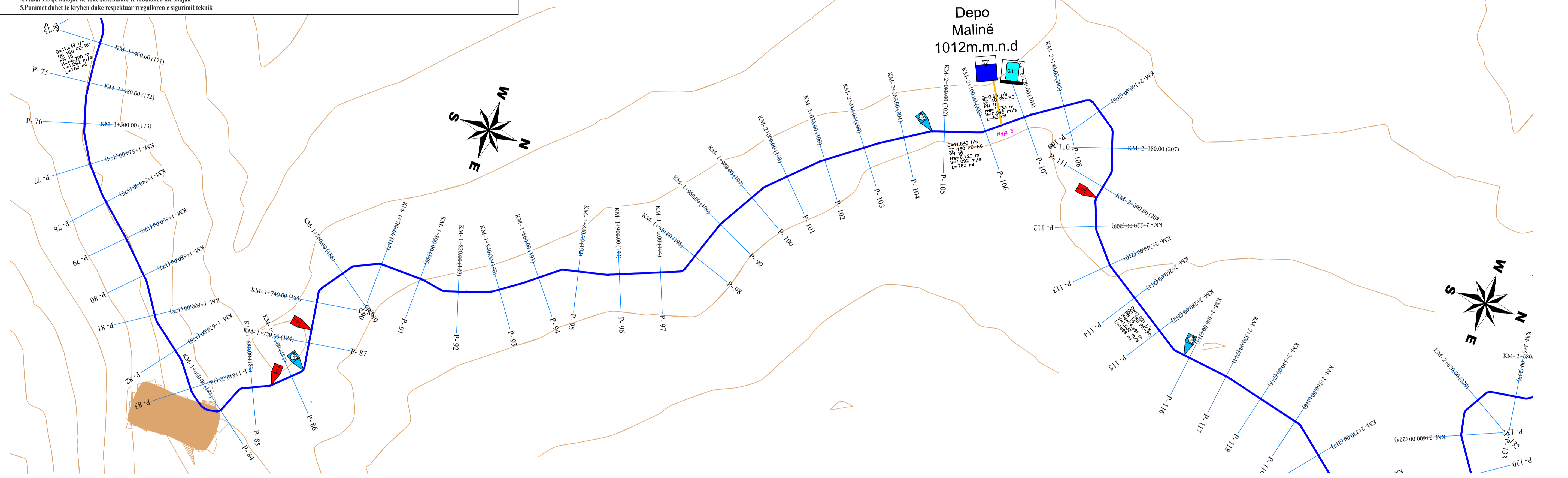
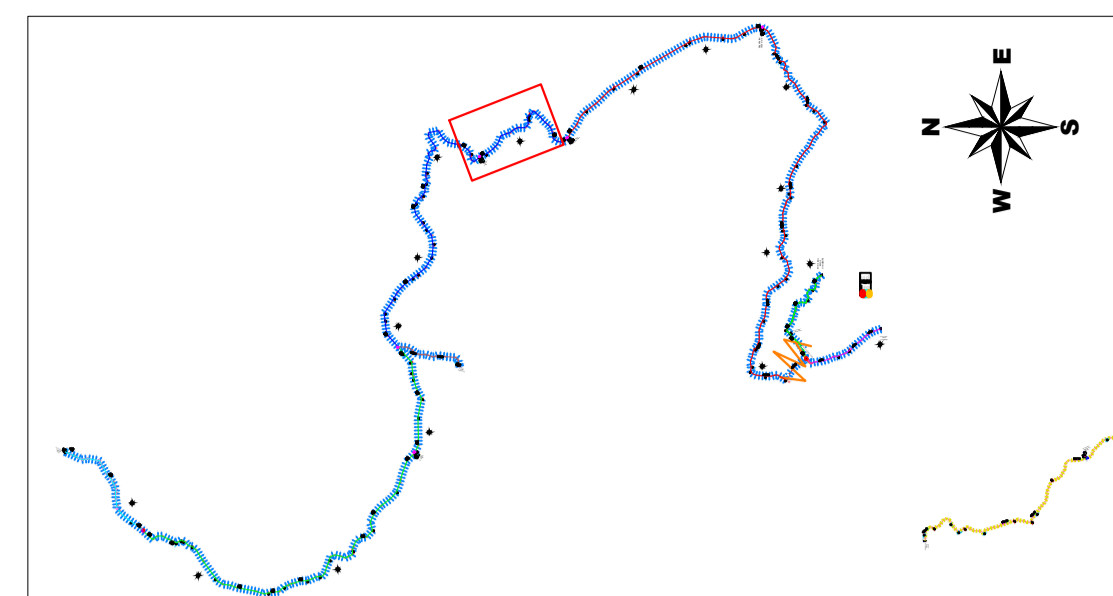

NUMRI PIKETES	75	76	77	78	79	80	81	82	83	84	85	86	87	88	89	90	91	92	93	94	95	96	97	98	99	100	101	102	103	104	105	106	107	108	109	110	111	112		
DISTANCA PARCIALE	16,0	15,4	12,6	14,5	22,1	22,5	16,3	19,1	13,4	1,0	12,0	12,7	15,5	36,7	17,7	11,5	21,5	9,7	10,7	11,5	14,9	9,1	20,6	35,2	27,4	27,1	29,2	29,5	25,6	22,9	25,1	8,2	27,3	14,7	18,7	13,4	13,3			
DISTANCA PROGRESIVE	16,0	31,4	44,0	58,5	80,6	103,1	121,4	140,5	153,9	154,9	166,9	182,4	197,9	234,6	252,3	263,8	285,3	295,0	306,5	318,0	332,9	342,6	363,2	398,4	425,8	455,0	484,2	513,7	539,3	564,4	590,0	615,1	640,2	665,3	690,4	715,5	740,6	765,7		
ELEMENTET HIDRAULIK											Q=11,649 l/s H=6,720 m OD 180 PE-RC V=1,992 m/s L=760 ml										Q=11,649 l/s H=6,720 m OD 160 PE-RC V=1,992 m/s L=760 ml										Q=11,021 l/s H=4,981 m OD 160 PE-RC V=1,033 m/s L=1886 ml									

**Investitor :**  
**BASHKIA POGRADEC**  
 Adresa:  
 Bulevardi "Rreshit Collaku"  
 Pogradec - Shqipëri  
 Web: www.bashkiapogradec.al  
 Email: bashkiapogradec@gmail.com



**Objekti:** "NDËRTIM UJËSJELLËSI RAJONAL TREBINJË - BURIMET E KOZICËS"  
 Numri i projektit: **AL\_PG\_N\_U\_R\_T-B\_K**  
 Vendodhja e projektit: **POGRADEC**

Grupi teknik i projektimit:  
**"ERALD-G" shpk Nr. Lic. N- 5304/11**  
 Rruga "KONGRESI I LUSHNYES"  
 Tiranë  
 eraldgshpk@yahoo.com  
 Tel +355 4 357 970  
 Cel +355 682090392



Administrator:  
**Gëzim ISLAMI**  
 Inxhinier Konstruktor:  
**Gëzim ISLAMI** Lic. K-1196/6  
 Inxhinier Hidroteknik:  
**Ersida VERCANI** Lic. K-1807/2

Arkitekt:  
**Elton CARCANI** Lic. A-0733/3  
 Inxhinier Elektrik:  
**Hajdar KURTI** Lic. E-0180/5  
 Inxhinier Topograf:  
**Kujtim CANAMETI** Lic. T-1058/3

Inxhinier Mekanik:  
**Arben MUHA** Lic. M-0308/3  
 Inxhinier Gjeolog:  
**Leonard KAZANXHIU** Lic. GJ-0556/3  
 Inxhinier Infrastrukturate:  
**Gëzim ISLAMI** Lic. K-1196/6

Inxhinier Teknolog:  
**Ylber CANI**  
 Inxhinier Mjedisit:  
**Nensi MEHMETI**  
 Emërtimi i fletës:  
**PROFILI GJATESOR DEPO KALIVAC - DEPO PLESHISHT**

Faza e projektit:  
**Projekt Zbatimi**  
 Formati: **A1**  
 Shkalla: **SHV 1:100, SHH 1:1000**  
 Nr i fletes: **P.GJ.09**  
 Data: **2020**

**PLANI I PERGJITHSHEM LINJA KYRESORE**

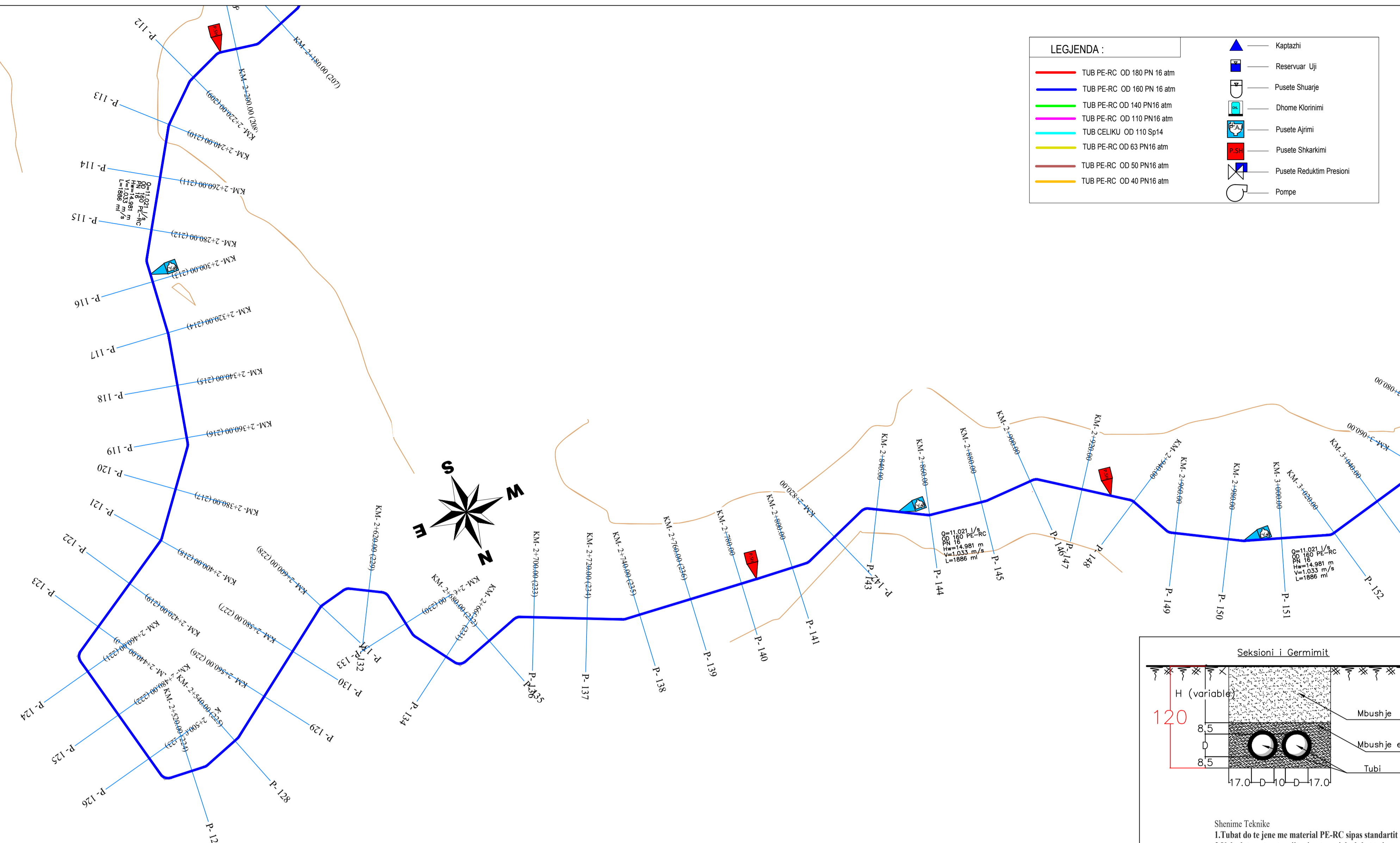
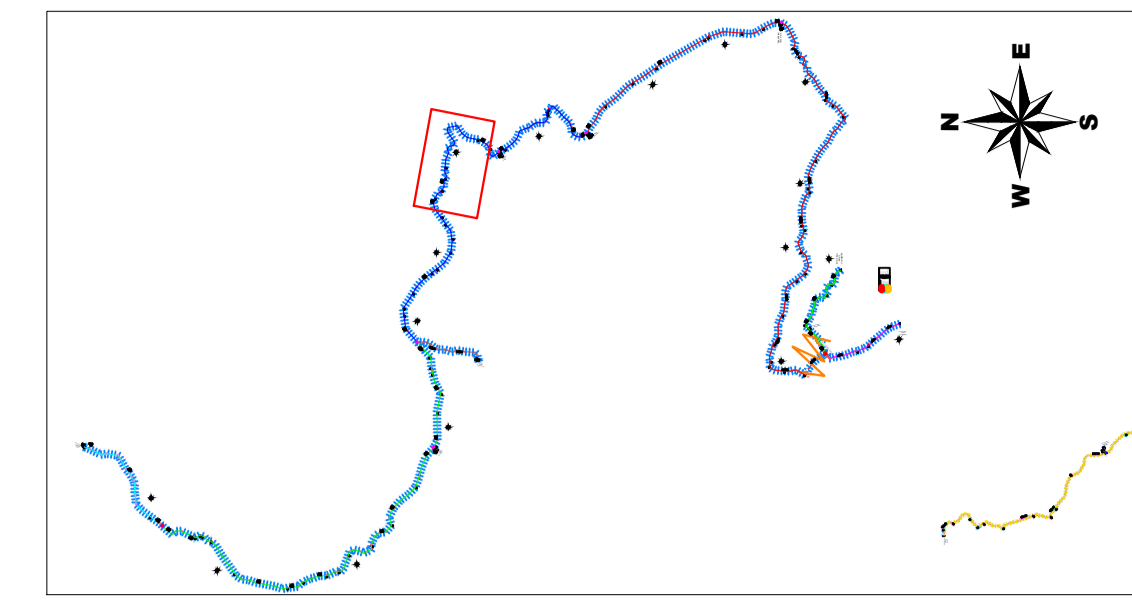

**LEGJENDA :**

	TUB PE-RC OD 180 PN 16 atm		Kapzahi
	TUB PE-RC OD 160 PN 16 atm		Reservuar Uji
	TUB PE-RC OD 140 PN16 atm		Pusetë Shuarje
	TUB PE-RC OD 110 PN16 atm		Dhromë Klorinimi
	TUB CELIKU OD 110 Sp14		Pusetë Ajrimi
	TUB PE-RC OD 63 PN16 atm		Pusetë Shkarkimi
	TUB PE-RC OD 50 PN16 atm		Pusetë Reduktim Presioni
	TUB PE-RC OD 40 PN16 atm		Pompe

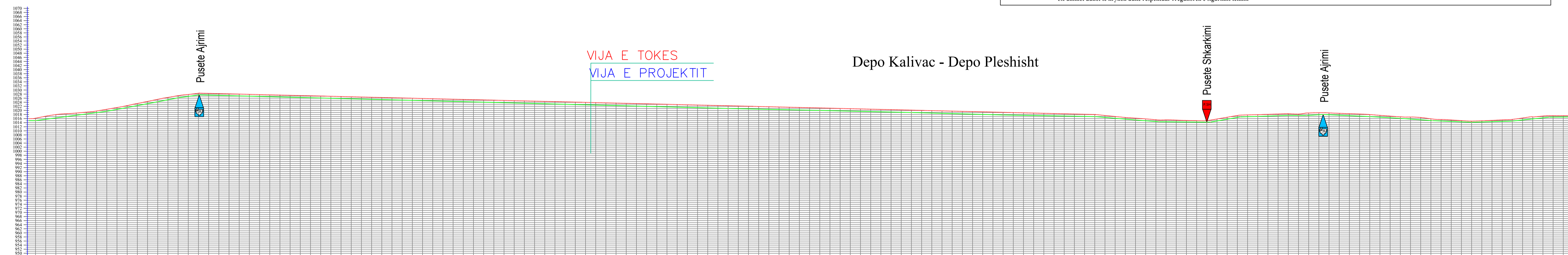
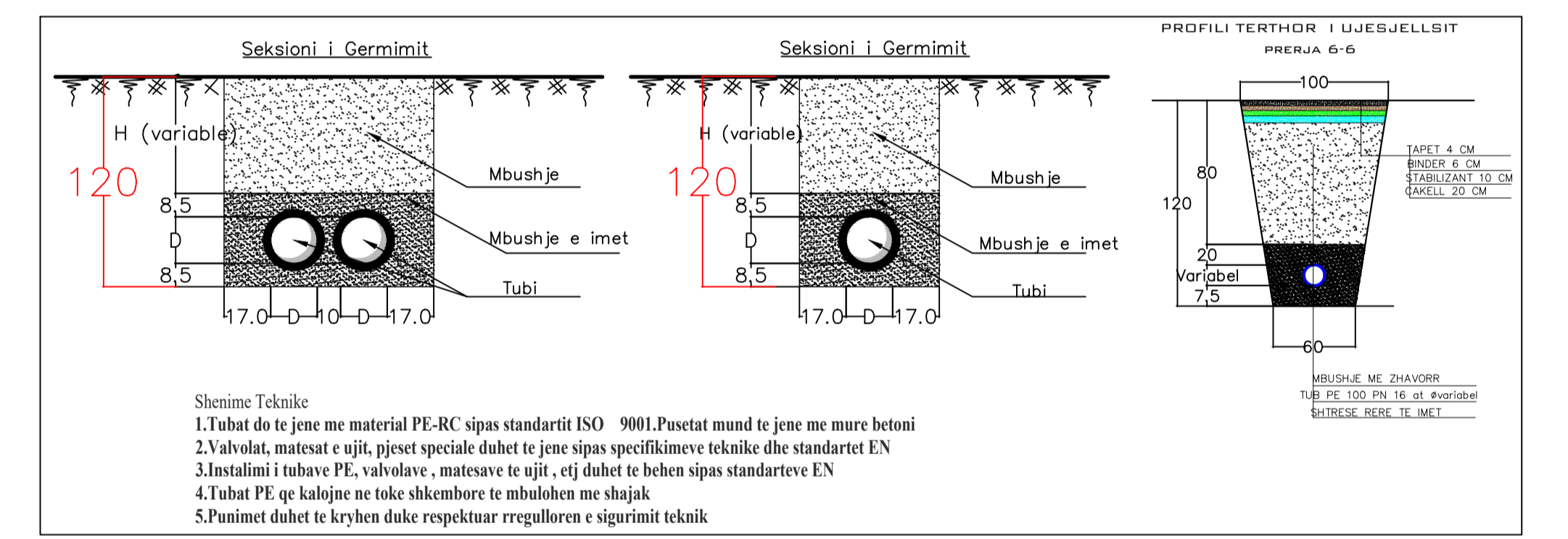

NUMRI PIKETES	112	113	114	115	116	117	118	119	120	121	122	123	124	125	126	127	128	129	130	131	132	133	134	135	136	137	138	139	140	141	142	143	144	145	146	147	148	149
DISTANCA PARCIALE	13.3	17.4	50.2		28.3	40.9	35.6	50.8																					0.0	19.5	27.1	22.1	21.3	18.8	35.3	16.0	23.2	
DISTANCA PROGRESIVE	13.3	30.7	80.9		109.2	150.1	185.7	236.5																				19.5	47.6	74.7	96.8	118.1	139.4	160.7	196.0	212.0	235.2	

**Investitor :**  
**BASHKIA POGRADEC**  
Adresa:  
Bulevardi "Rreshit Collaku"  
Pogradec - Shqipëri  
Web: www.bashkiapogradec.al  
Email:bashkiapogradec@gmail.com



**Objekti: "NDËRTIM UJËSJELLËSI RAJONAL TREBINJË - BURIMET E KOZICËS"**

Numri i projektit: **AL\_PG\_N\_U\_R\_T-B\_K**  
Vendodhja e projektit: **POGRADEC**

Grupi teknik i projektimit:  
**"ERALD-G" shpk Nr.lic. N- 5304/11**

Ruga "KONGRESI I LUSHNJES"  
Tirane  
eraldgshpk@yahoo.com  
Tel +355 4 357 970  
Cel +355 682090392

Administrator:  
**Gëzim ISLAMI**

Inxhinier Konstruktor:  
**Gëzim ISLAMI** Lic. K-1196/6

Inxhinier Hidroteknik:  
**Ersida VERCANI** Lic. K-1807/2

Arkitekt:  
**Elton CARCANI** Lic. A-0733/3

Inxhinier Elektrik:  
**Hajdar KURTI** Lic. E-0180/5

Inxhinier Topograf:  
**Kujtim CANAMETI** Lic. T-1058/3

Inxhinier Mekanik:  
**Arben MUHA** Lic. M-0308/3

Inxhinier Gjeolog:  
**Leonard KAZANXHIU** Lic. GJ-0556/3

Inxhinier Infrastruktura:  
**Gëzim ISLAMI** Lic. K-1196/6

Inxhinier Teknolog:  
**Ylber CANI**

Inxhinier Mjeshtesi:  
**Nensi MEHMETI**

Emërtimi i fletës:  
**PROFILI GJATESOR DEPO KALIVAC - DEPO PLESHISHT**

Faza e projektit:  
**Projekt Zbatimi**

Formati: **A1**  
Shkalla: **SHV 1:100, SHH 1:1000**

Nr i fletes: P.GJ.10

Data:  
**2020**

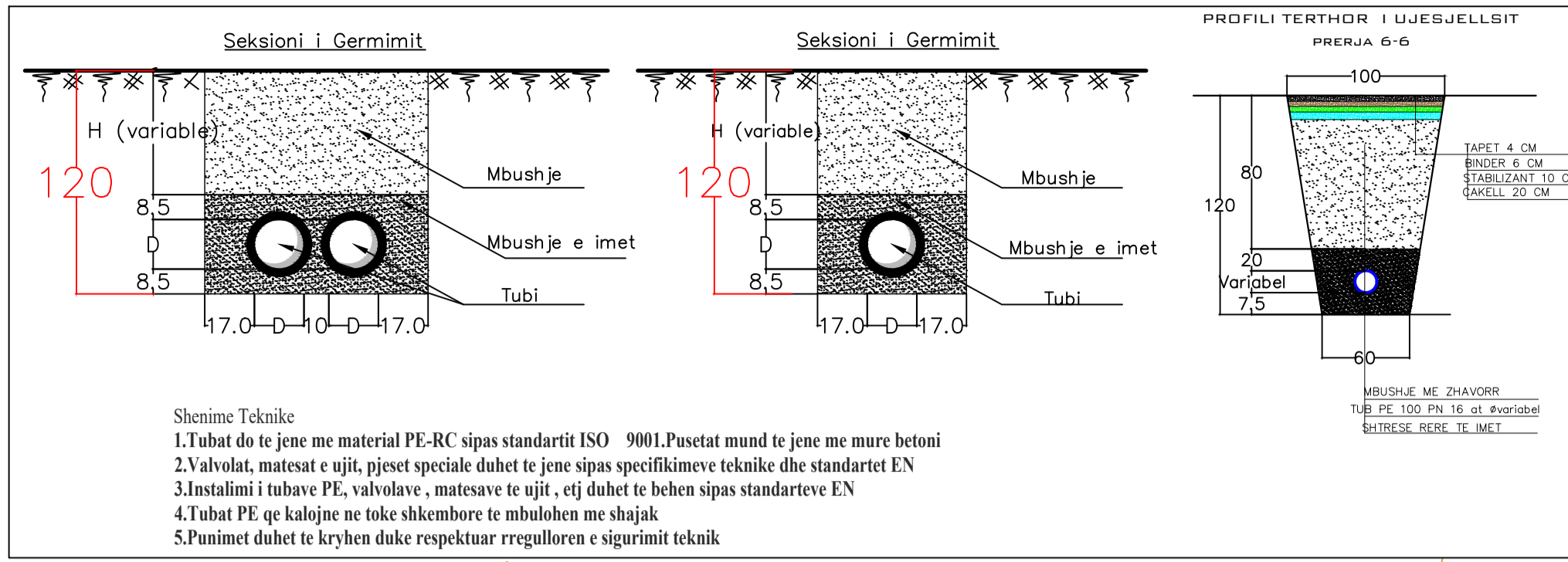

**LEGJENDA :**

- TUB PE-RC OD 180 PN 16 atm
- TUB PE-RC OD 160 PN 16 atm
- TUB PE-RC OD 140 PN 16 atm
- TUB PE-RC OD 110 PN 16 atm
- TUB CELIKU OD 110 Sp14
- TUB PE-RC OD 63 PN 16 atm
- TUB PE-RC OD 50 PN 16 atm
- TUB PE-RC OD 40 PN 16 atm

- Kapazi
- Reservuar Uji
- Pusete Shuarje
- Dhome Klorinimi
- Pusete Ajrimi
- Pusete Shkarkimi
- Pusete Reduktim Presioni
- Pompe

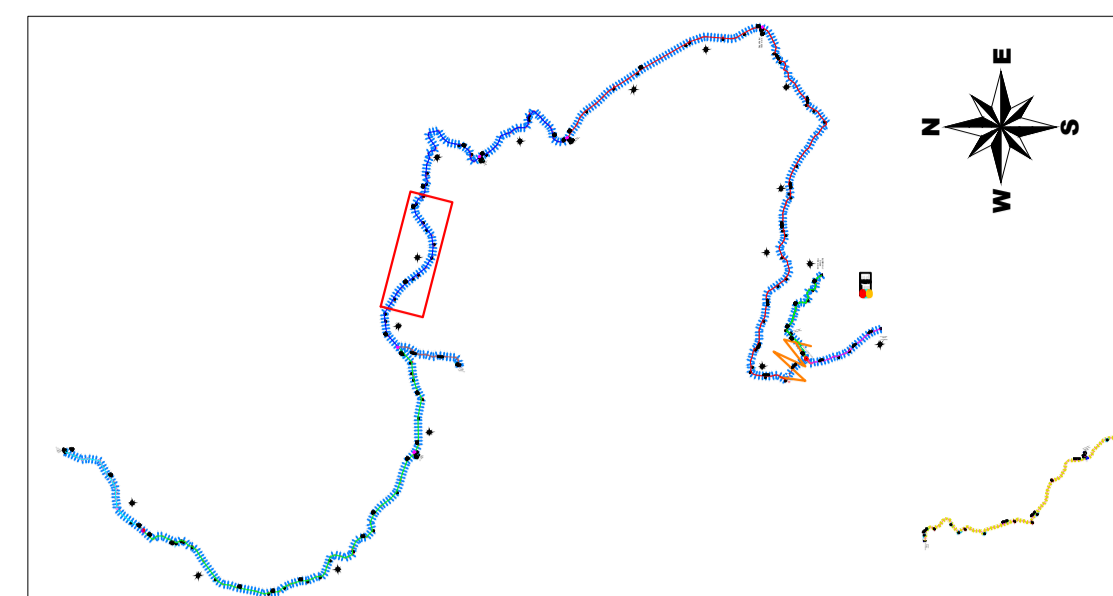

**Shenime Teknike**

1. Tubat do jene me material PE-RC sipas standartit ISO 9001. Pusetat mund te jene me mure betoni
2. Valvolat, matesat e ujit, pjeset speciale duhet te jene sipas specifikimeve teknike dhe standartet EN
3. Instalimi i tubave PE, valvolave, matesave te ujit, etj duhet te behen sipas standarteve EN
4. Tubat PE qe kalojne ne toke shkemboire te mbulohe me shajak
5. Punimet duhet te kryhen duke respektuar rregulloren e sigurimit teknik

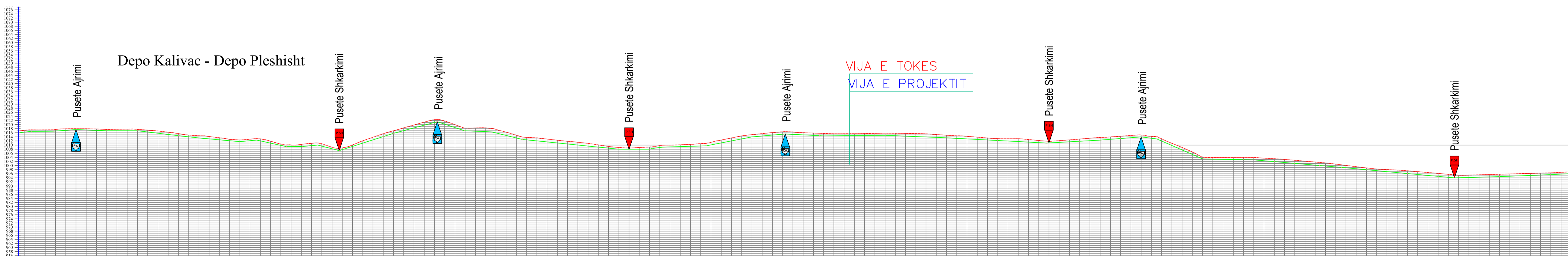
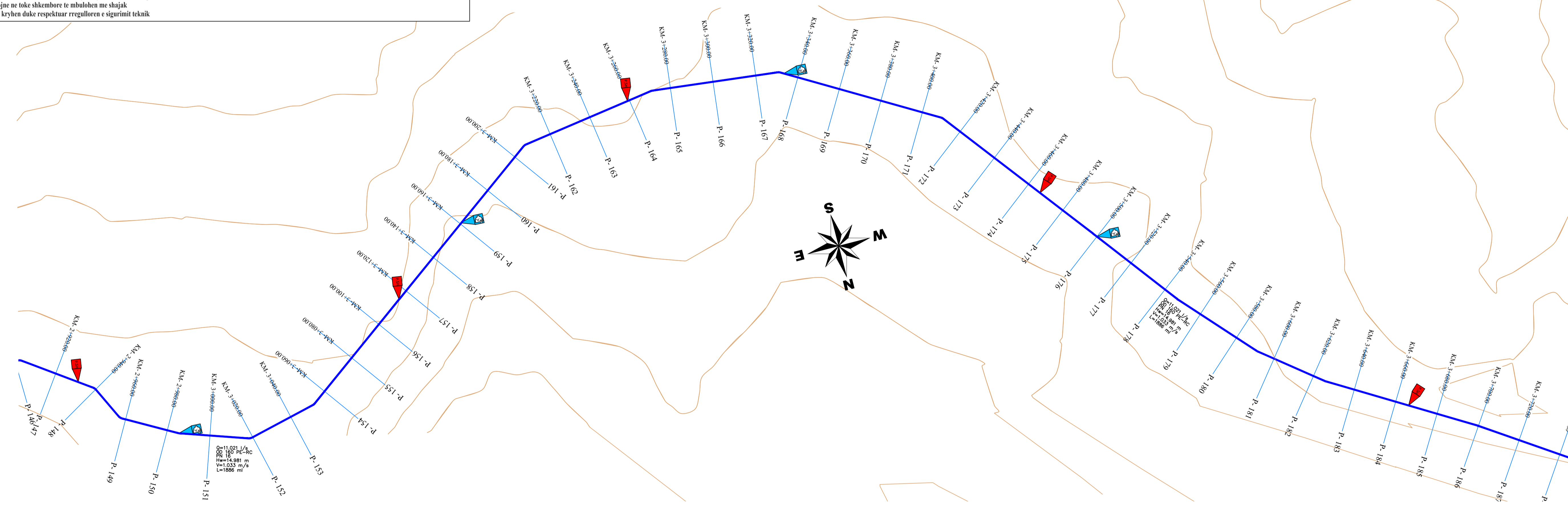

NUMRI PIKETES	349	150	151	152	153	154	155	156	157	158	159	160	161	162	163	164	165	166	167	168	169	170	171	172	173	174	175	176	177	178	179	180	181	182	183	184	185	186	
DISTANCA PARCIALE		26.8		32.0		31.7		62.1		91.4		62.9		58.5		77.3		87.3		347.6		46.5		347.2		43.6		311.9		343.9		311.9		71.6		389.8			
DISTANCA PROGRESIVE																																							
ELEMENTET HIDRAULIK																																							

**Investitor :**  
**BASHKIA POGRADEC**  
Adresa:  
Bulevardi "Reshit Collaku"  
Pogradec - Shqipëri  
Web: www.bashkiapogradec.al  
Email: bashkiapogradec@gmail.com



**Objekti:** "NDËRTIM UJËSJELLËSI RAJONAL TREBINJË - BURIMET E KOZICËS"  
Numri i projektit: **AL\_PG\_N\_U\_R\_T-B\_K**  
Vendodhja e projektit: **POGRADEC**

Grupi teknik i projektimit:  
**"ERALD-G" shpk Nr. Lic. N- 5304/11**  
Rruga "KONGRESI I LUSHNYES"  
Tirane  
eraldgshpk@yahoo.com  
Tel +355 4 357 970  
Cel +355 682090392

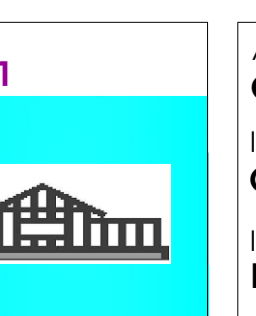

Administrator:  
**Gëzim ISLAMI**  
Inxhinier Konstruktor:  
**Gëzim ISLAMI** Lic. K-1196/6  
Inxhinier Hidroteknik:  
**Ersida VERCANI** Lic. K-1807/2

Arkitekt:  
**Elton CARCANI** Lic. A-0733/3  
Inxhinier Elektrik:  
**Hajdar KURTI** Lic. E-0180/5  
Inxhinier Topograf:  
**Kujtim CANAMETI** Lic. T-1058/3

Inxhinier Mekanik:  
**Arben MUHA** Lic. M-0308/3  
Inxhinier Gjeolog:  
**Leonard KAZANXHIU** Lic. GJ-0556/3  
Inxhinier Infrastruktura:  
**Gëzim ISLAMI** Lic. K-1196/6

Inxhinier Teknolog:  
**Ylber CANI**  
Inxhinier Kujdesis:  
**Nensi MEHMETI**  
Emërtimi i fletës:  
**PROFILI GJATESOR DEPO KALIVAC - DEPO PLESHISHT**

Faza e projektit:  
**Projekt Zbatimi**  
Formati: **A1**  
Shkalla: **SHV 1:100, SHH 1:1000**  
Nr i fletes: **P.GJ.11**  
Data: **2020**

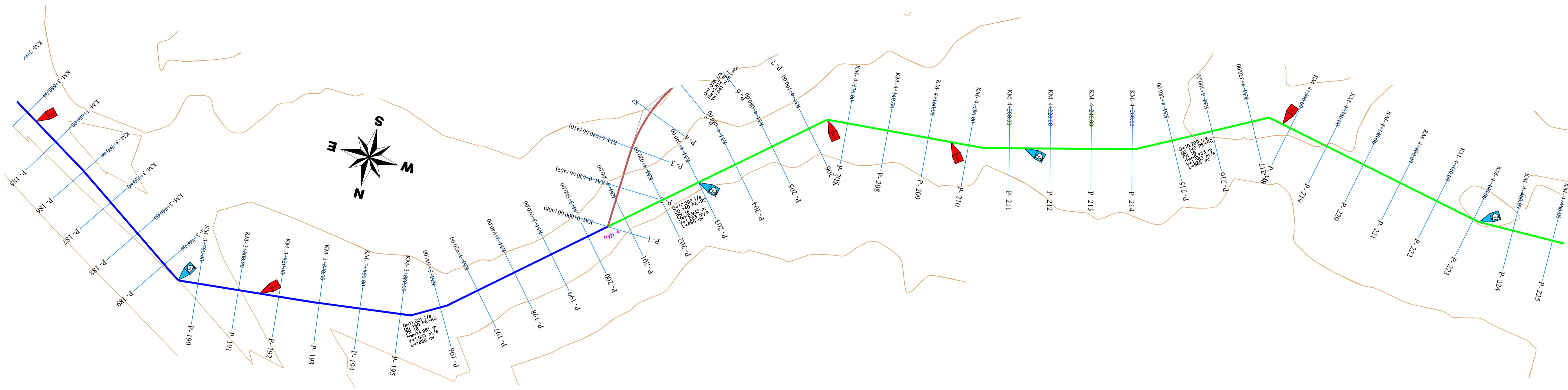
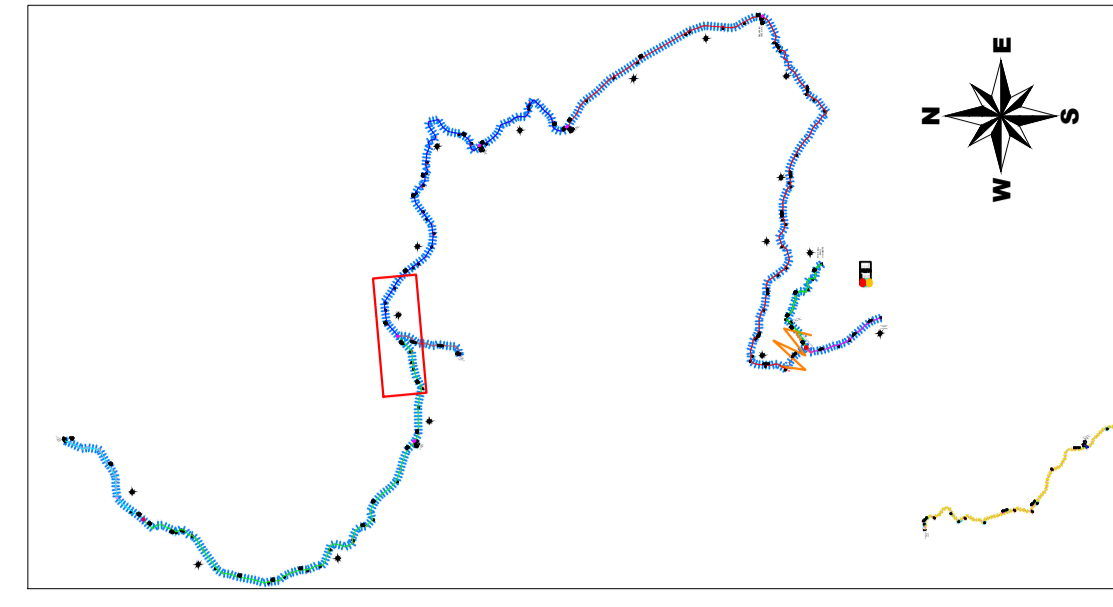
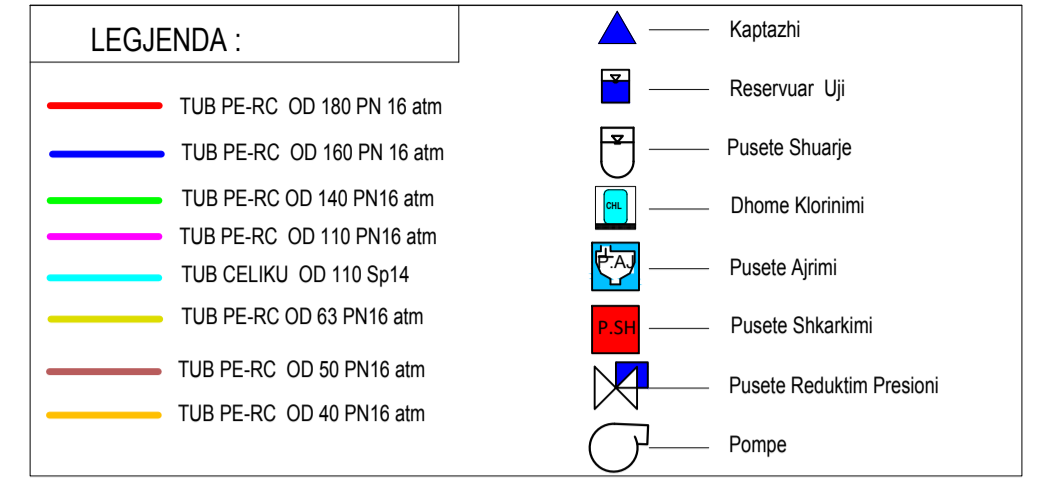
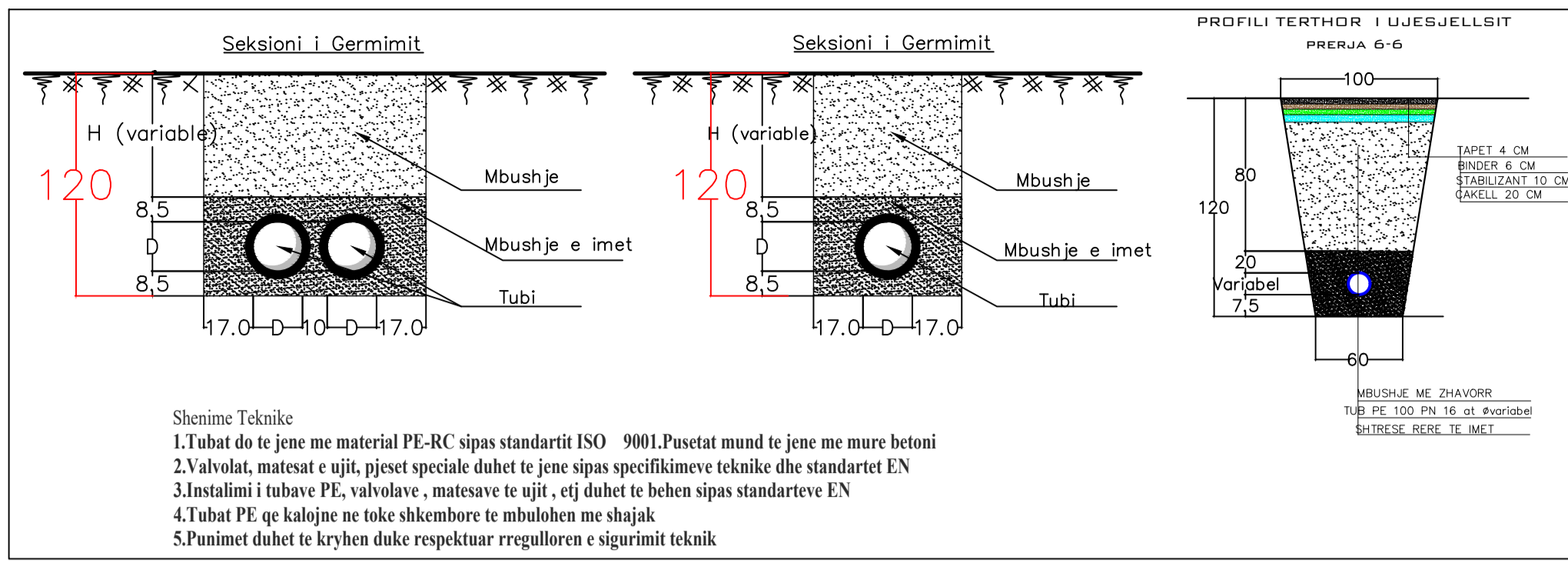

Depo Pevëlanc - Depo Pleshisht  
945 m.m.n.d

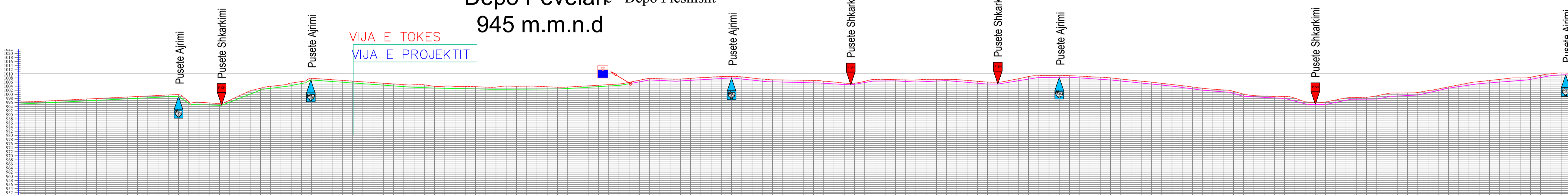

NUMRI PIKETES	186	187	188	189	190	191	192	193	194	195	196	197	198	199	200	201	202	203	204	205	206	207	208	209	210	211	212	213	214	215	216	217	218	219	220	221	222	223		
DISTANCA PARCIALE		69.3		64.9		48.0		17.1		87.3		118.1		76.3		73.3		65.5		112.4		448.9		487.7		488.9		65.5		66.5		112.4		448.9		487.7		488.9		
DISTANCA PROGRESIVE	3998.9			4068.2		4132.2		4149.3		4266.6		4384.7		4461.0		4537.3		4602.8		4676.1		4788.5		4837.2		4913.5		4979.0		5044.5		5110.0		5175.5		5241.0		5306.5		5372.0
ELEMENTET HIDRAULIK				Pusete Ajrimi		Pusete Shkarkimi		Pusete Ajrimi		Pusete Shkarkimi		Pusete Shkarkimi		Pusete Shkarkimi		Pusete Shkarkimi		Pusete Shkarkimi		Pusete Shkarkimi		Pusete Shkarkimi		Pusete Shkarkimi		Pusete Shkarkimi		Pusete Shkarkimi		Pusete Shkarkimi		Pusete Shkarkimi		Pusete Shkarkimi		Pusete Shkarkimi		Pusete Shkarkimi		Pusete Shkarkimi

**Investitor :** BASHKIA POGRADEC  
**Adresa:** Bulevardi "Rreshit Collaku" Pogradec - Shqipëri  
 Web: www.bashkiapogradec.al  
 Email:bashkiapogradec@gmail.com

**Objekti:** "NDËRTIM UJËSJELLËSI RAJONAL TREBINJË - BURIMET E KOZICËS"

**Grupi teknik i projektimit:** "ERALD-G" shpk Nr.lic. N- 5304/11  
 Rruga "KONGRESI I LUSHNJES" Tiranë  
 eraldgshpk@yahoo.com  
 Tel +355 4 357 970  
 Cel +355 682090392

**Administrator:** Gëzim ISLAMI  
**Inxhinier Konstruktor:** Gëzim ISLAMI Lic. K-1196/6  
**Inxhinier Hidroteknik:** Ersida VERCANI Lic. K-1807/2

**Arkitekt:** Elton CARCANI Lic. A-0733/3  
**Inxhinier Elektrik:** Hajdar KURTI Lic. E-0180/5  
**Inxhinier Topograf:** Kujtim CANAMETI Lic. T-1058/3

**Inxhinier Mekanik:** Arben MUHA Lic. M-0308/3  
**Inxhinier Gjeolog:** Leonard KAZANXHIU Lic. GJ-0556/3  
**Inxhinier Infrastrukturate:** Gëzim ISLAMI Lic. K-1196/6

**Inxhinier Teknolog:** Ylber CANI  
**Inxhinier Mjedisit:** Nensi MEHMETI  
 Emërtimi i fletës: PROFILI GJATESOR DEPO KALIVAC - DEPO PLESHISHT

**Faza e projektit:** Projekt Zbatimi  
**Formati:** A1  
**Shkalla:** SHV 1:100, SHH 1:1000  
**Nr i fletes:** P.G.12  
**Data:** 2020

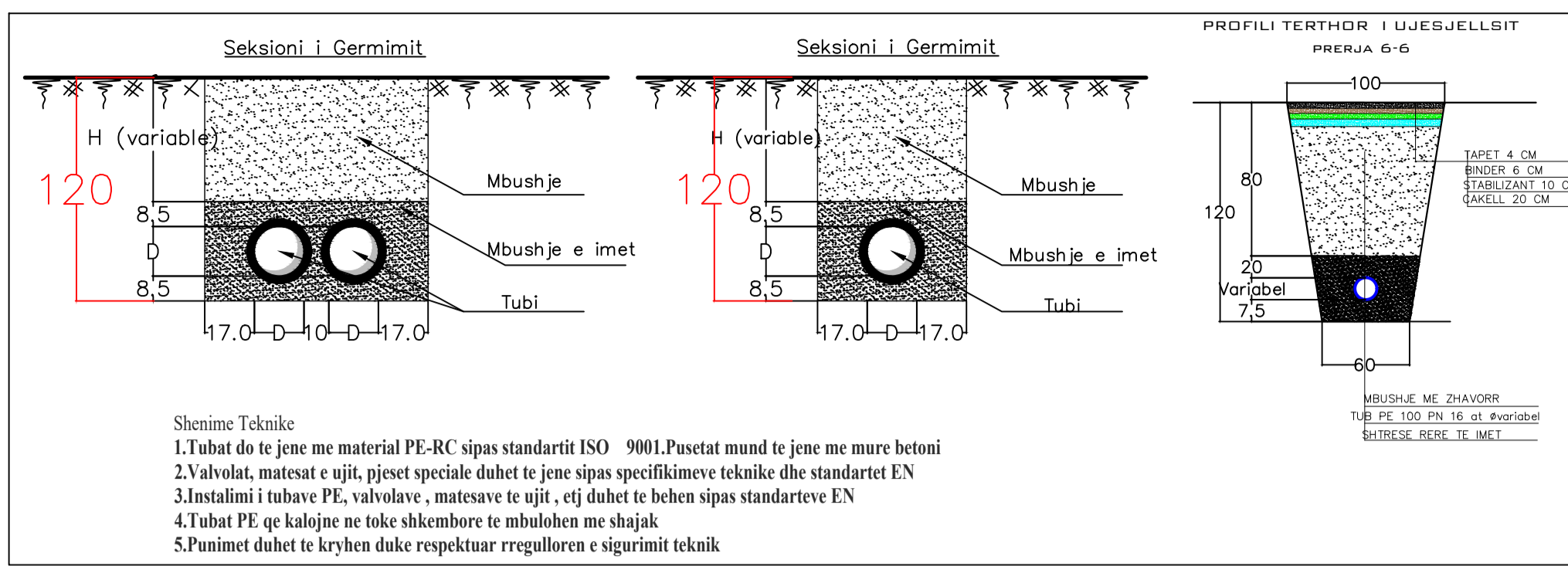

**LEGJENDA :**

	TUB PE-RC OD 180 PN 16 atm		Kapazhi
	TUB PE-RC OD 160 PN 16 atm		Reservuar Uji
	TUB PE-RC OD 140 PN16 atm		Pusete Shuarje
	TUB PE-RC OD 110 PN16 atm		Dhome Klorinimi
	TUB CELIKU OD 110 Sp14		Pusete Ajrimi
	TUB PE-RC OD 63 PN16 atm		Pusete Shkarkimi
	TUB PE-RC OD 50 PN16 atm		Pusete Reduktim Presioni
	TUB PE-RC OD 40 PN16 atm		Pompe

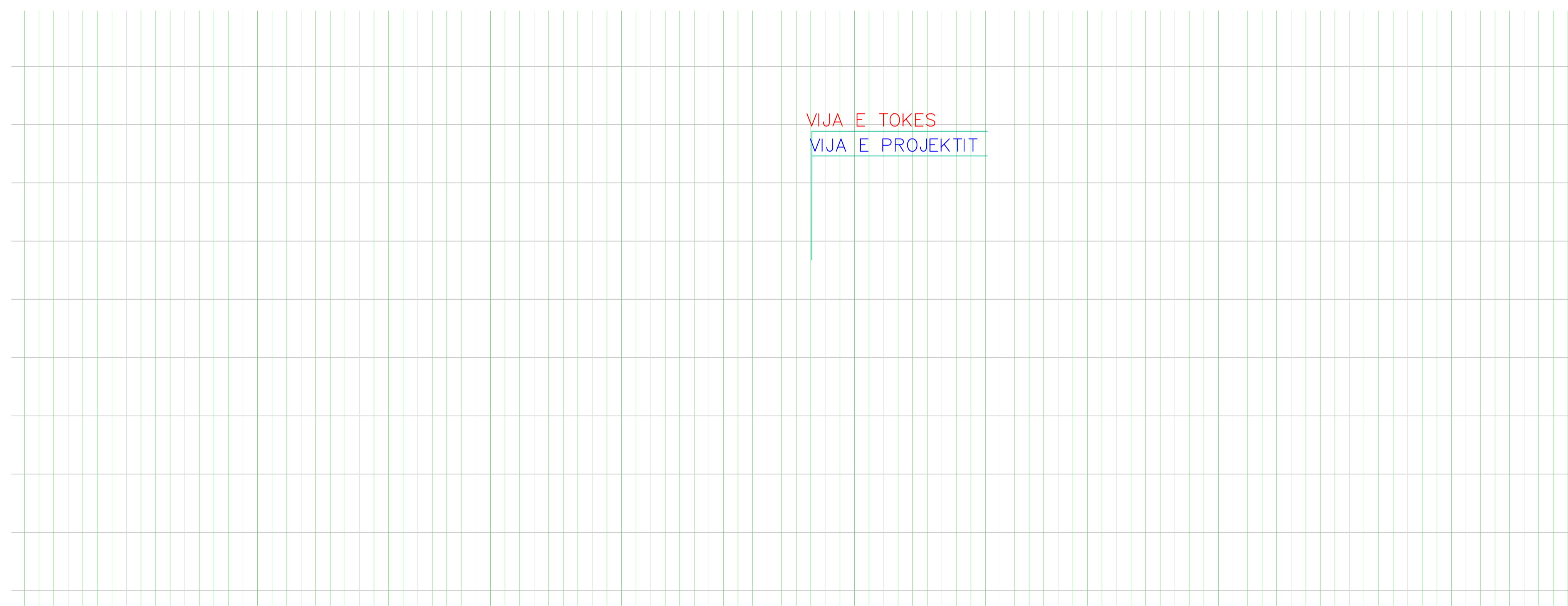
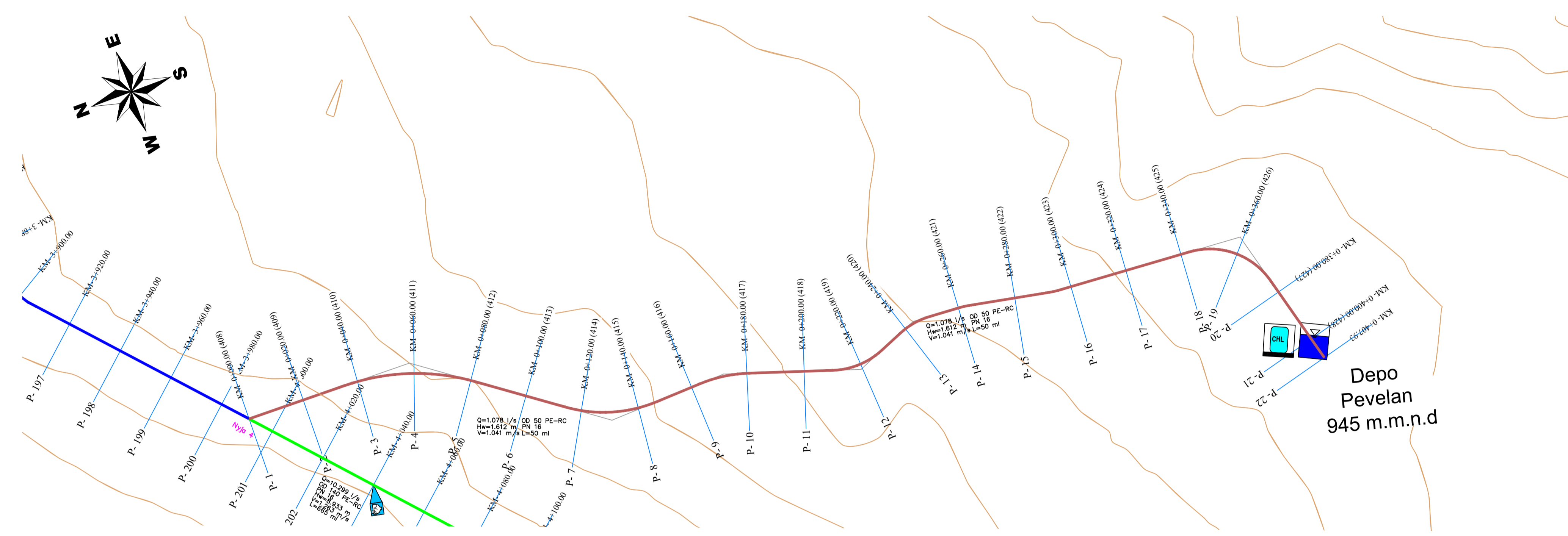
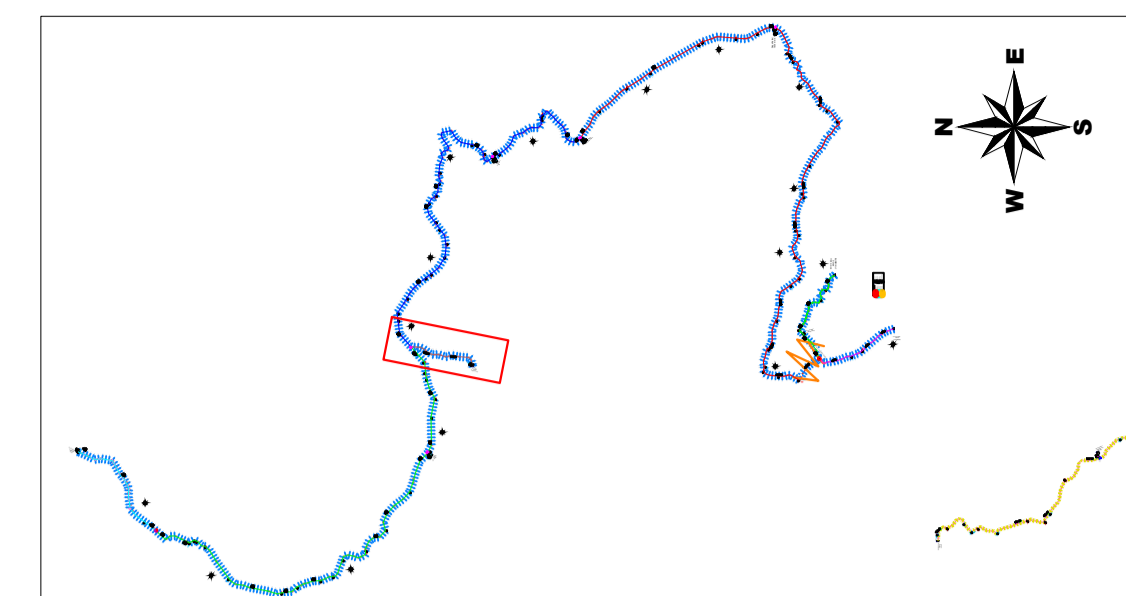

**Investitor :**  
**BASHKIA POGRADEC**  
 Adresa:  
 Bulevardi "Reshit Collaku"  
 Pogradec - Shqipëri  
 Web: www.bashkiapogradec.al  
 Email: bashkiapogradec@gmail.com



**Objekti:** "NDËRTIM UJËSJELLËSI  
 RAJONAL TREBINJË - BURIMET  
 E KOZICËS"  
 Numri i projektit: **AL\_PG\_N\_U\_R\_T\_B\_K**  
 Vendodhja e projektit: **POGRADEC**

Grupi teknik i projektimit:  
**"ERALD-G" shpk Nr. Lic. N- 5304/11**  
 Rruga "KONGRESI I LUSHNYES"  
 Tiranë  
 eraldgshpk@yahoo.com  
 Tel +355 4 357 970  
 Cel +355 682090392



Administrator:  
**Gëzim ISLAMI**  
 Inxhinier Konstruktor:  
**Gëzim ISLAMI** Lic. K-1196/6  
 Inxhinier Hidroteknik:  
**Ersida VERCANI** Lic. K-1807/2

Arkitekt:  
**Eltan CARCANI** Lic. A-0733/3  
 Inxhinier Elektrik:  
**Hajdar KURTI** Lic. E-0180/5  
 Inxhinier Topograf:  
**Kujtim CANAMETI** Lic. T-1058/3

Inxhinier Mekanik:  
**Arben MUHA** Lic. M-0308/3  
 Inxhinier Gjeolog:  
**Leonard KAZANXHIU** Lic. GJ-0556/3  
 Inxhinier Infrastruktura:  
**Gëzim ISLAMI** Lic. K-1196/6

Inxhinier Teknolog:  
**Ylber CANI**  
 Inxhinier Mjedisit:  
**Nensi MEHMETI**  
 Emërtimi i fletës:  
**PROFILI GJATESOR  
 LINJA KRYESORE - DEPO PEVLAN**

Faza e projektit:  
**Projekt Zbatimi**  
 Formati: **A1**  
 Shkalla: SHV 1:100,  
 SHH 1:1000  
 Nr i fletes: P.GJ.13  
 Data:  
**2020**



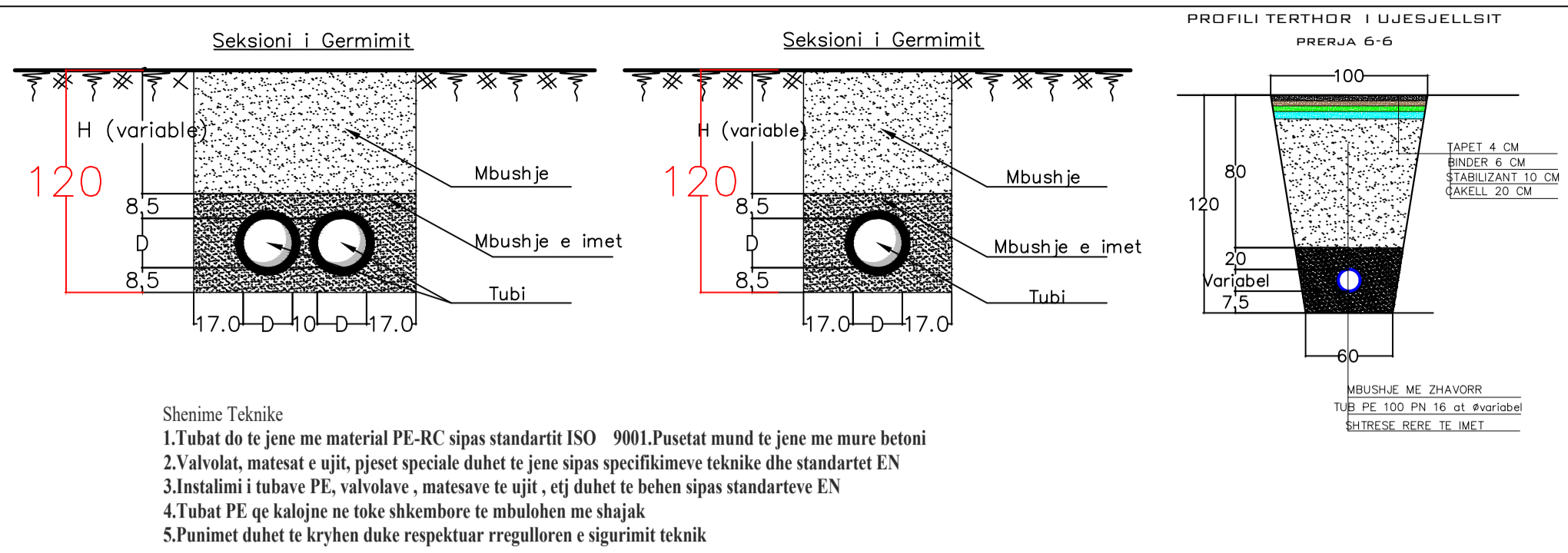

LEGJENDA :

- TUB PE-RC OD 180 PN 16 atm
- TUB PE-RC OD 160 PN 16 atm
- TUB PE-RC OD 140 PN16 atm
- TUB PE-RC OD 110 PN16 atm
- TUB CEЛИKU OD 110 Sp14
- TUB PE-RC OD 63 PN16 atm
- TUB PE-RC OD 50 PN16 atm
- TUB PE-RC OD 40 PN16 atm

- Kapazi
- Reservuar Uji
- Pusete Shuarje
- Dhomer Klorinimi
- Pusete Ajrimi
- Pusete Shkarkimi
- Pusete Reduktim Presioni
- Pompe

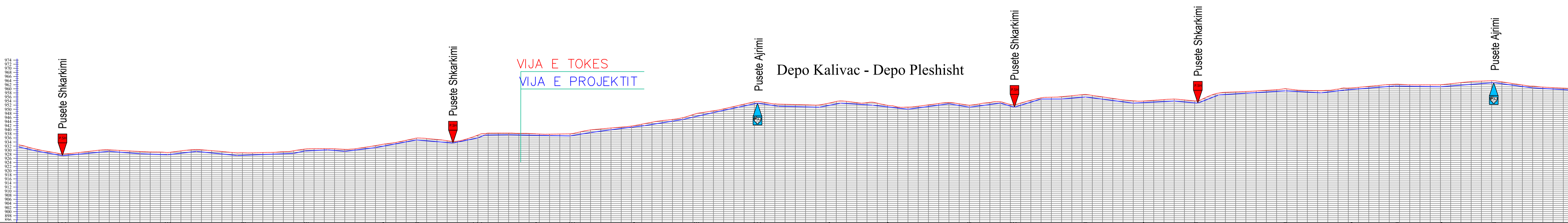
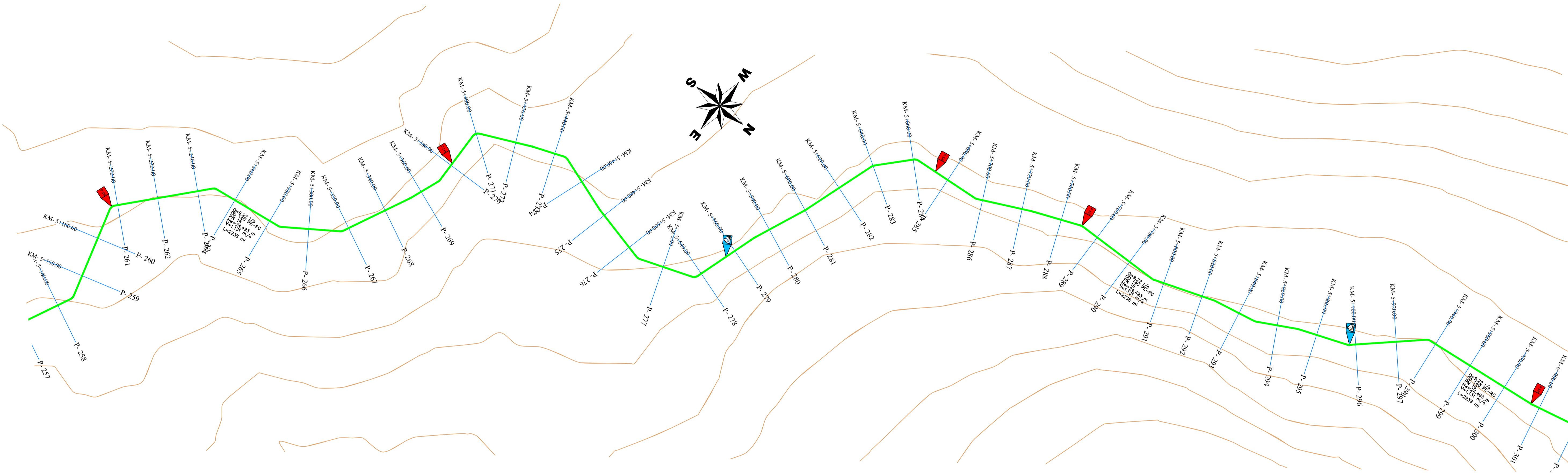
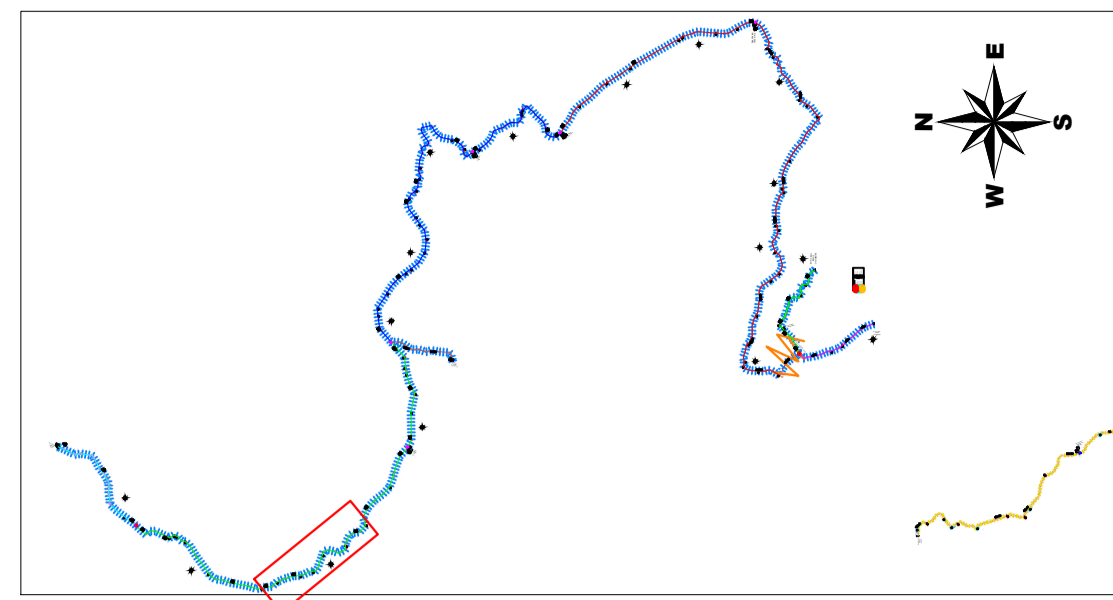

NUMRI PIKETES	260	261	262	263	264	265	266	267	268	269	270	271	272	273	274	275	276	277	278	279	280	281	282	283	284	285	286	287	288	289	290	291	292	293	294	295	296	297				
KUOTA E TOKES	938.44	938.44	938.44	938.44	938.44	938.44	938.44	938.44	938.44	938.44	938.44	938.44	938.44	938.44	938.44	938.44	938.44	938.44	938.44	938.44	938.44	938.44	938.44	938.44	938.44	938.44	938.44	938.44	938.44	938.44	938.44	938.44	938.44	938.44	938.44	938.44	938.44	938.44				
KUOTA E PROJEKTIT	938.44	938.44	938.44	938.44	938.44	938.44	938.44	938.44	938.44	938.44	938.44	938.44	938.44	938.44	938.44	938.44	938.44	938.44	938.44	938.44	938.44	938.44	938.44	938.44	938.44	938.44	938.44	938.44	938.44	938.44	938.44	938.44	938.44	938.44	938.44	938.44	938.44	938.44	938.44			
DIFERENCA	0.00	0.00	0.00	0.00	0.00	0.00	0.00	0.00	0.00	0.00	0.00	0.00	0.00	0.00	0.00	0.00	0.00	0.00	0.00	0.00	0.00	0.00	0.00	0.00	0.00	0.00	0.00	0.00	0.00	0.00	0.00	0.00	0.00	0.00	0.00	0.00	0.00	0.00	0.00			
KUOTA E PIKETES	938.44	938.44	938.44	938.44	938.44	938.44	938.44	938.44	938.44	938.44	938.44	938.44	938.44	938.44	938.44	938.44	938.44	938.44	938.44	938.44	938.44	938.44	938.44	938.44	938.44	938.44	938.44	938.44	938.44	938.44	938.44	938.44	938.44	938.44	938.44	938.44	938.44	938.44	938.44			
DISTANCA PARCIALE		48.7	35.0	28.9	36.5	33.8	15.8	26.8	26.5	16.2	29.0	29.4	33.4	38.2	38.9	19.6	33.2	27.6	34.9	42.5	31.6	21.5	20.9	24.9	37.9																	
DISTANCA PROGRESIVE	0+00	0+48.7	0+83.7	0+112.6	0+149.1	0+182.9	0+198.7	0+225.5	0+252.0	0+268.2	0+297.2	0+326.6	0+360.0	0+398.2	0+437.1	0+456.7	0+490.0	0+523.2	0+557.9	0+592.8	0+627.4	0+661.9	0+696.1	0+730.0	0+764.4	0+799.3	0+834.2	0+869.1	0+904.0	0+938.9	0+973.8	0+1008.7	0+1043.6	0+1078.5	0+1113.4	0+1148.3	0+1183.2	0+1218.1	0+1253.0			
ELEMENTET HIDRAULIK																																										

Investitor : **BASHKIA POGRADEC**  
Adresa:  
Bulevardi "Reshit Collaku"  
Pogradec - Shqipëri  
Web: [www.bashkiapogradec.al](http://www.bashkiapogradec.al)  
Email: [bashkiapogradec@gmail.com](mailto:bashkiapogradec@gmail.com)



**Objekti:** "NDËRTIM UJËSJELLËSI RAJONAL TREBINJË - BURIMET E KOZICËS"  
  
Numri i projektit: **AL\_PG\_N\_UR\_T\_B\_K** Vendi i projektit: **POGRADEC**

Grupi teknik i projektimit: **"ERALD-G" shpk Nr .lic. N- 5304/11**  
Rruga "KONGRESI I LUSHNJES" Tirane  
[eraldgshpk@yahoo.com](mailto:eraldgshpk@yahoo.com)  
Tel +355 4 357 970  
Cel +355 682090392

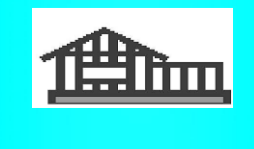

Administrator:  
**Gëzim ISLAMI**  
Inxhinier Konstruktiv:  
**Gëzim ISLAMI** Lic. K-1196/6  
Inxhinier Hidroteknik:  
**Ersida VERCANI** Lic. K-1807/2

Arkitekt:  
**Elton CARCANI** Lic. A-0733/3  
Inxhinier Elektrik:  
**Hajdar KURTI** Lic. E-0180/5  
Inxhinier Topograf:  
**Kujtim CANAMETI** Lic. T-1058/3

Inxhinier Mekanik:  
**Arben MUHA** Lic. M-0308/3  
Inxhinier Gjeolog:  
**Leonard KAZANXHIU** Lic. GJ-0556/3  
Inxhinier Infrastrukture:  
**Gëzim ISLAMI** Lic. K-1196/6

Inxhinier Teknolog:  
**Ylber CANI**  
Inxhinier Mjedisit:  
**Nensi MEHMETI**  
Emërtimi i fletës:  
**PROFILI GJATESOR DEPO KALIVAC - DEPO PLESHISHT**

Faza e projektit:  
**Projekt Zbatimi**  
Formati: **A1**  
Shkalla: SHV 1:100  
SHH 1:1000  
Nr i fletes: P.GJ.15  
Data: **2020**

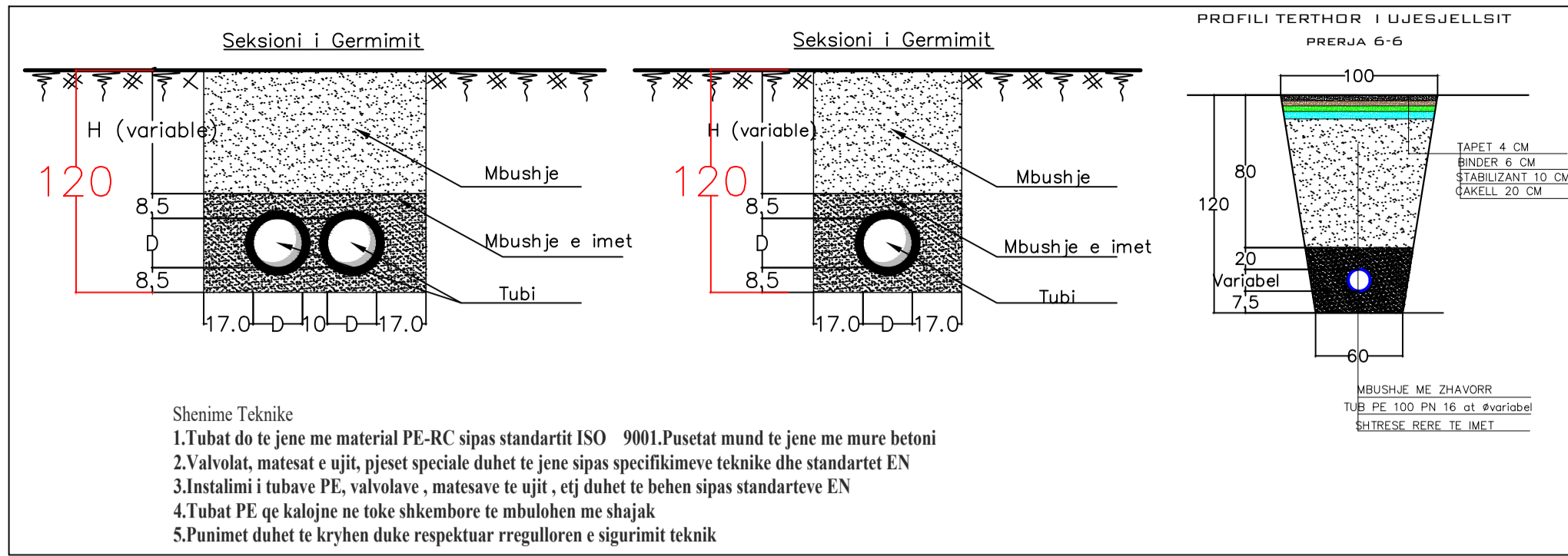

**LEGJENDA :**

- TUB PE-RC OD 180 PN 16 atm
- TUB PE-RC OD 160 PN 16 atm
- TUB PE-RC OD 140 PN16 atm
- TUB PE-RC OD 110 PN16 atm
- TUB CELIKU OD 110 Sp14
- TUB PE-RC OD 63 PN16 atm
- TUB PE-RC OD 50 PN16 atm
- TUB PE-RC OD 40 PN16 atm

- Kapazi
- Reservuar Uj
- Pusete Shuarje
- Dhoma Klorinimi
- Pusete Ajrimi
- Pusete Shkarkimi
- Pusete Reduktim Presioni
- Pompe

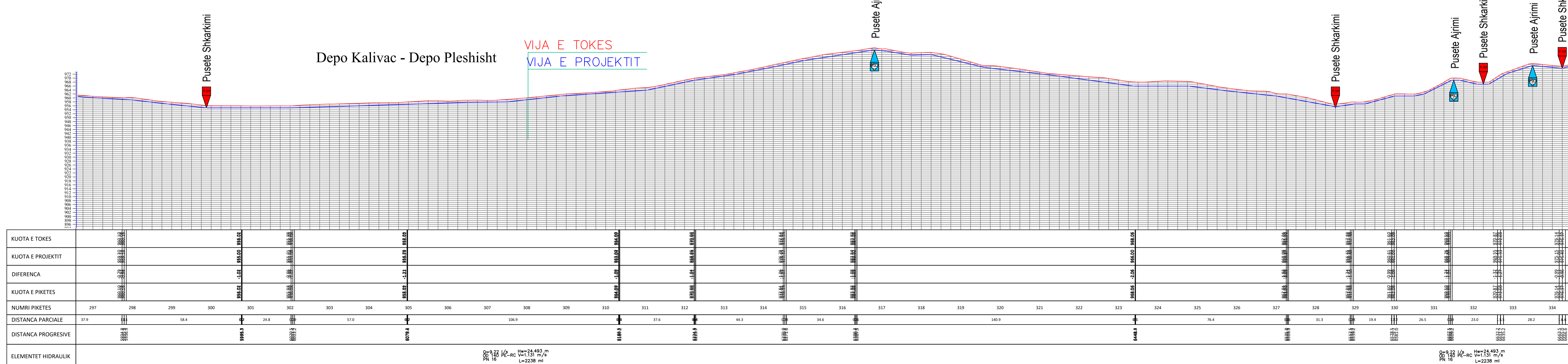
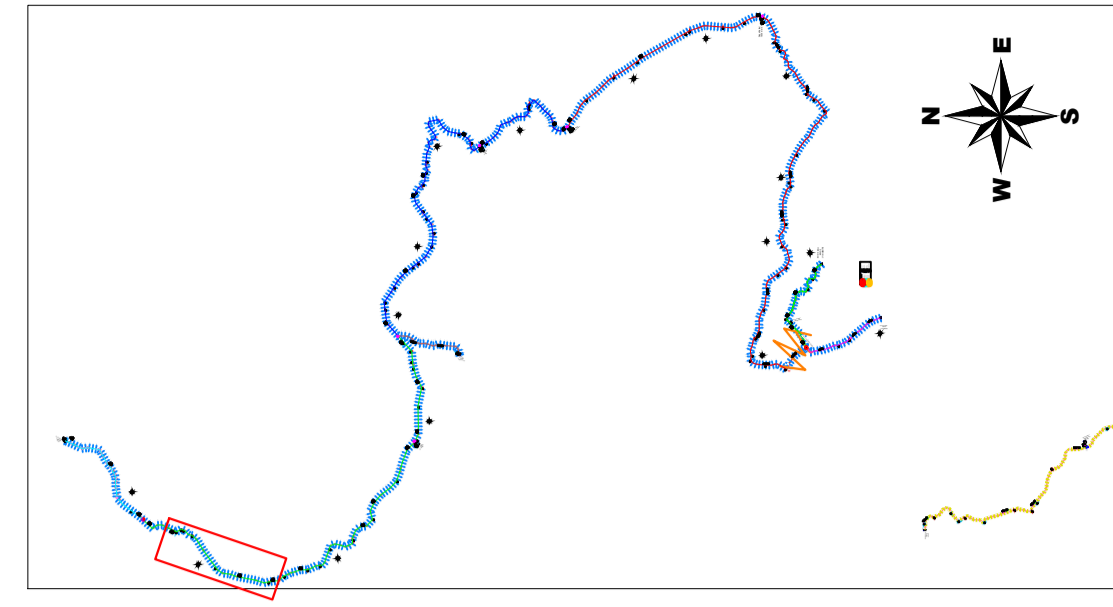

**Investitor :**  
**BASHKIA POGRADEC**  
 Adresa:  
 Bulevardi "Reshit Collaku"  
 Pogradec - Shqipëri  
 Web: www.bashkiapogradec.al  
 Email:bashkiapogradec@gmail.com



**Objekti:** "NDËRTIM UJËSJELLËSI RAJONAL TREBINJË - BURIMET E KOZICËS"  
 Numri i projektit: **AL\_PG\_N\_U\_R\_T-B\_K**  
 Vendodhja e projektit: **POGRADEC**

Grupi teknik i projektimit:  
**"ERALD-G" shpk Nr. Lic. N- 5304/11**  
 Rruga "KONGRESI I LUSHNJES"  
 Tirane  
 eraldghpk@yahoo.com  
 Tel +355 4 357 970  
 Cel +355 682090392



Administrator:  
**Gëzim ISLAMI**  
 Inxhinier Konstruktor:  
**Gëzim ISLAMI** Lic. K-1196/6  
 Inxhinier Hidroteknik:  
**Ersida VERCANI** Lic. K-1807/2

Arkitekt:  
**Elton CARCANI** Lic. A-0733/3  
 Inxhinier Elektrik:  
**Hajdar KURTI** Lic. E-0180/5  
 Inxhinier Topograf:  
**Kujtim CANAMETI** Lic. T-1058/3

Inxhinier Mekanik:  
**Arben MUHA** Lic. M-0308/3  
 Inxhinier Gjeolog:  
**Leonard KAZANXHIU** Lic. GJ-0556/3  
 Inxhinier Infrastruktura:  
**Gëzim ISLAMI** Lic. K-1196/6

Inxhinier Teknolog:  
**Ylber CANI**  
 Inxhinier Mjekësia:  
**Nensi MEHMETI**  
 Emërtimi i fletës:  
**PROFILI GJATESOR DEPO KALIVAC - DEPO PLESHISHT**

Faza e projektit:  
**Projekt Zbatimi**  
 Formati: **A1**  
 Shkalla: SHV 1:100, SHH 1:1000  
 Nr i fletes: P.GJ.16  
 Data: **2020**



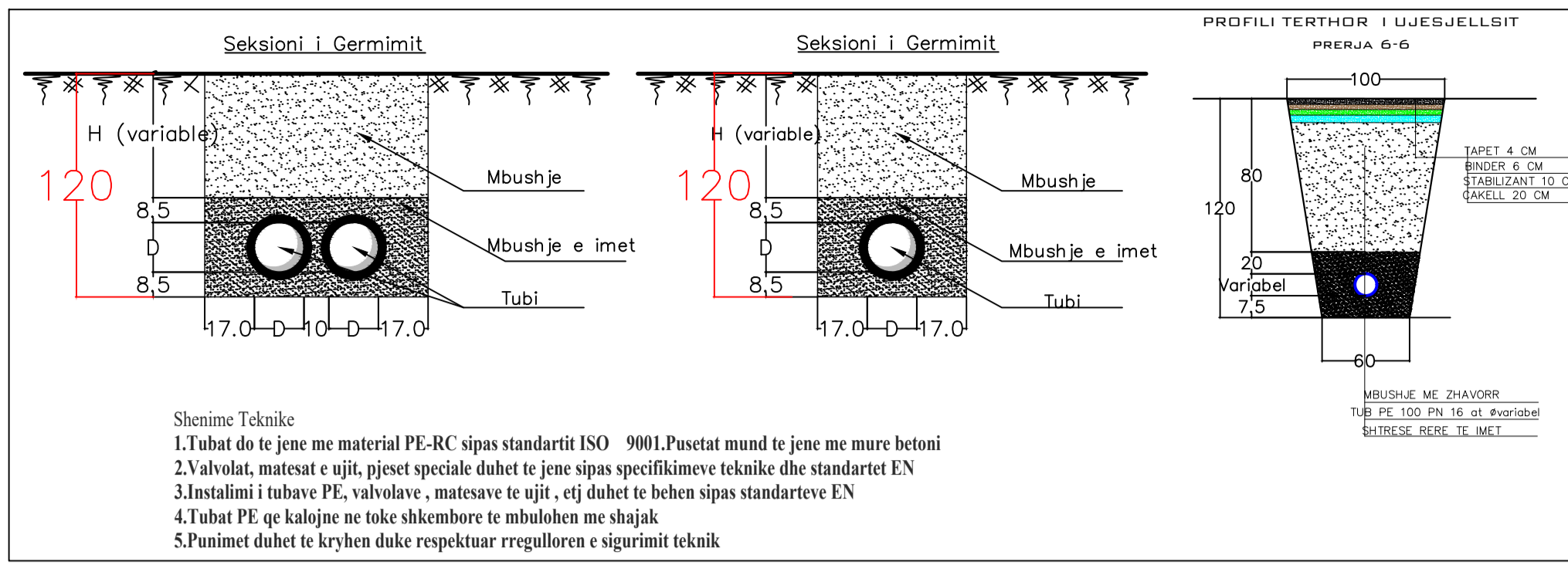

**LEGJENDA :**

- TUB PE-RC OD 180 PN 16 atm
- TUB PE-RC OD 160 PN 16 atm
- TUB PE-RC OD 140 PN 16 atm
- TUB PE-RC OD 110 PN 16 atm
- TUB CELIKU OD 110 Sp14
- TUB PE-RC OD 63 PN 16 atm
- TUB PE-RC OD 50 PN 16 atm
- TUB PE-RC OD 40 PN 16 atm

- Kapazhi
- Reservuar Uj
- Pusete Shuarje
- Dhome Klorinimi
- Pusete Ajrimi
- Pusete Shkarkimi
- Pusete Reduktim Presioni
- Pompe

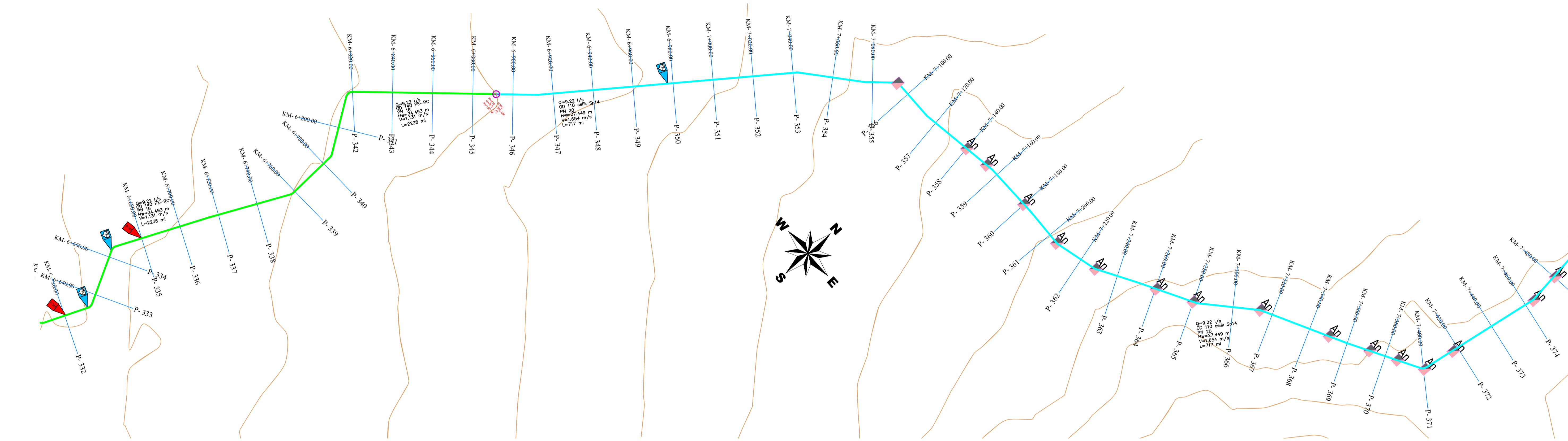
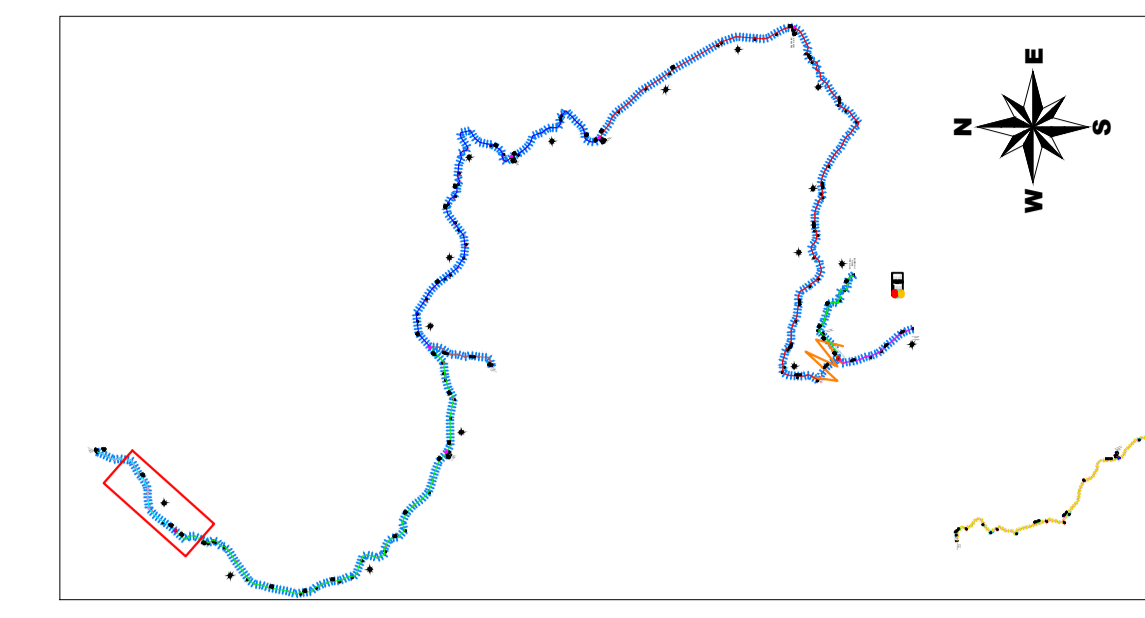

Depo Kalivac - Depo Pleshisht

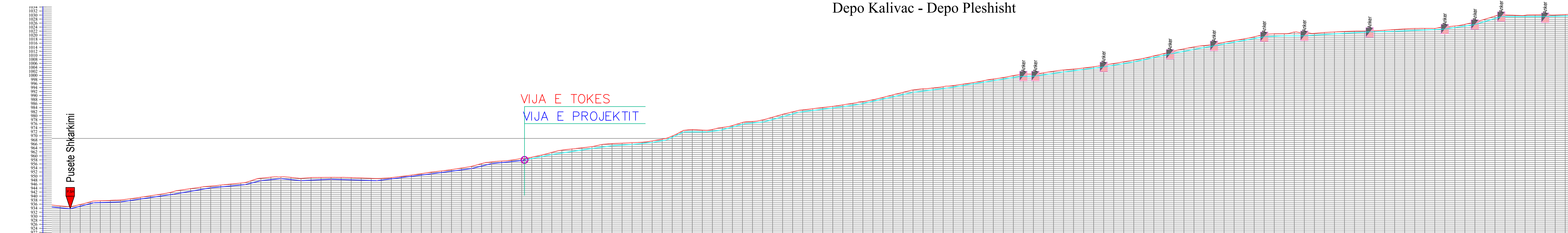

VIJA E TOKES  
VIJA E PROJEKTTIT

NUMRI PIKETES	334	335	336	337	338	339	340	341	342	343	344	345	346	347	348	349	350	351	352	353	354	355	356	357	358	359	360	361	362	363	364	365	366	367	368	369	370	371		
DISTANCA PARCIALE		48.6		42.0		25.4		29.4		91.9		129.5		33.1		14.8		20.5		41.7		28.1		71.8		20.0		21.4		23.3		29.5		30.9		45.2		36.0		
DISTANCA PROGRESIVE	6662.5	6711.1	6759.7	6808.3	6856.9	6905.5	6954.1	7002.7	7051.3	7100.0	7148.6	7197.2	7245.8	7294.4	7343.0	7391.6	7440.2	7488.8	7537.4	7586.0	7634.6	7683.2	7731.8	7780.4	7829.0	7877.6	7926.2	7974.8	8023.4	8072.0	8120.6	8169.2	8217.8	8266.4	8315.0	8363.6	8412.2	8460.8		
ELEMENTET HIDRAULIK																																								

**Investitor :**  
**BASHKIA POGRADEC**  
Adresa:  
Bulevardi "Reshit Collaku"  
Pogradec - Shqipëri  
Web: www.bashkiapogradec.al  
Email: bashkiapogradec@gmail.com



**Objekti:** "NDËRTIM UJËSJELLËSI RAJONAL TREBINJË - BURIMET E KOZICËS"  
Numri i projektit: **AL\_PG\_N\_U\_R\_T-B\_K**  
Vendodhja e projektit: **POGRADEC**

Grupi teknik i projektimit:  
**"ERALD-G" shpk Nr. Lic. N- 5304/11**  
Rruga "KONGRESI I LUSHNJES"  
Tirane  
eraldgshpk@yahoo.com  
Tel +355 4 357 970  
Cel +355 682090392

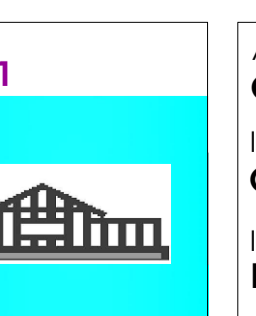

Administrator:  
**Gëzim ISLAMI**  
Inxhinier Konstruktor:  
**Gëzim ISLAMI**  
Lic. K-1196/6  
Inxhinier Hidroteknik:  
**Ersida VERCANI**  
Lic. K-1807/2

Arkitekt:  
**Elton CARCANI**  
Lic. A-0733/3  
Inxhinier Elektrik:  
**Hajdar KURTI**  
Lic. E-0180/5  
Inxhinier Topograf:  
**Kujtim CANAMETI**  
Lic. T-1058/3

Inxhinier Mekanik:  
**Arben MUHA**  
Lic. M-0308/3  
Inxhinier Gjeolog:  
**Leonard KAZANXHIU**  
Lic. GJ-0556/3  
Inxhinier Infrastruktura:  
**Gëzim ISLAMI**  
Lic. K-1196/6

Inxhinier Teknolog:  
**Ylber CANI**  
Inxhinier Bujqësi:  
**Nensi MEHMETI**  
Emërtimi i fletës:  
**PROFILI GJATESOR DEPO KALIVAC - DEPO PLESHISHT**

Faza e projektit:  
**Projekt Zbatimi**  
Formati: **A1**  
Shkalla: **SHV 1:100, SHH 1:1000**  
Nr i fletes: **P.GJ.17**  
Data: **2020**

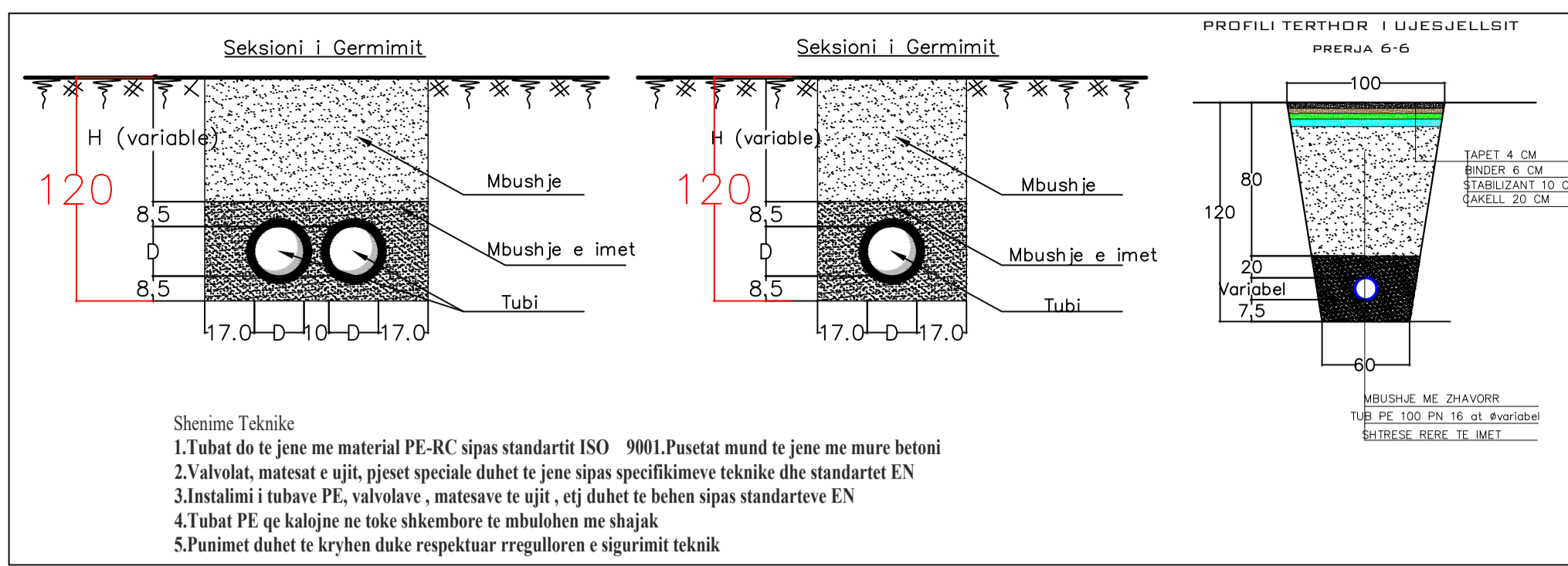

**LEGJENDA :**

- TUB PE-RC OD 180 PN 16 atm
- TUB PE-RC OD 160 PN 16 atm
- TUB PE-RC OD 140 PN16 atm
- TUB PE-RC OD 110 PN16 atm
- TUB CELIKU OD 110 Sp14
- TUB PE-RC OD 63 PN16 atm
- TUB PE-RC OD 50 PN16 atm
- TUB PE-RC OD 40 PN16 atm

- Kapzahi
- Reservuar Uj
- Pusete Shuarje
- Dhome Klorinimi
- Pusete Ajrimi
- Pusete Shkarkimi
- Pusete Reduktim Presioni
- Pompe

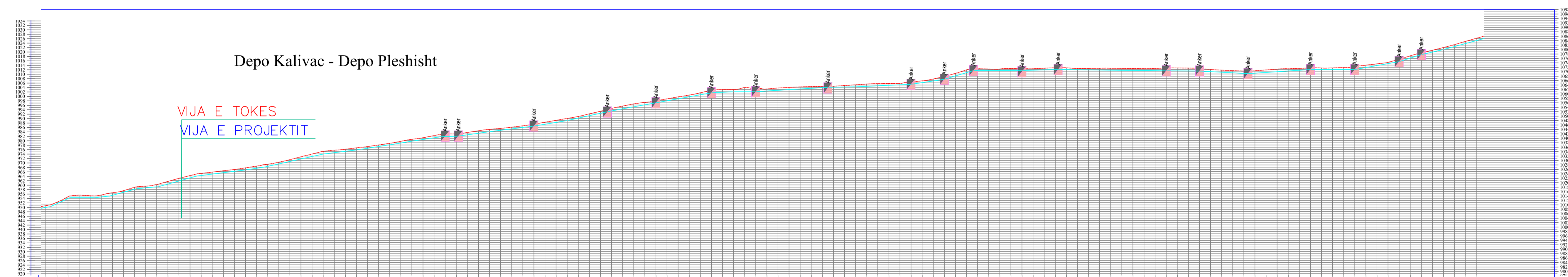
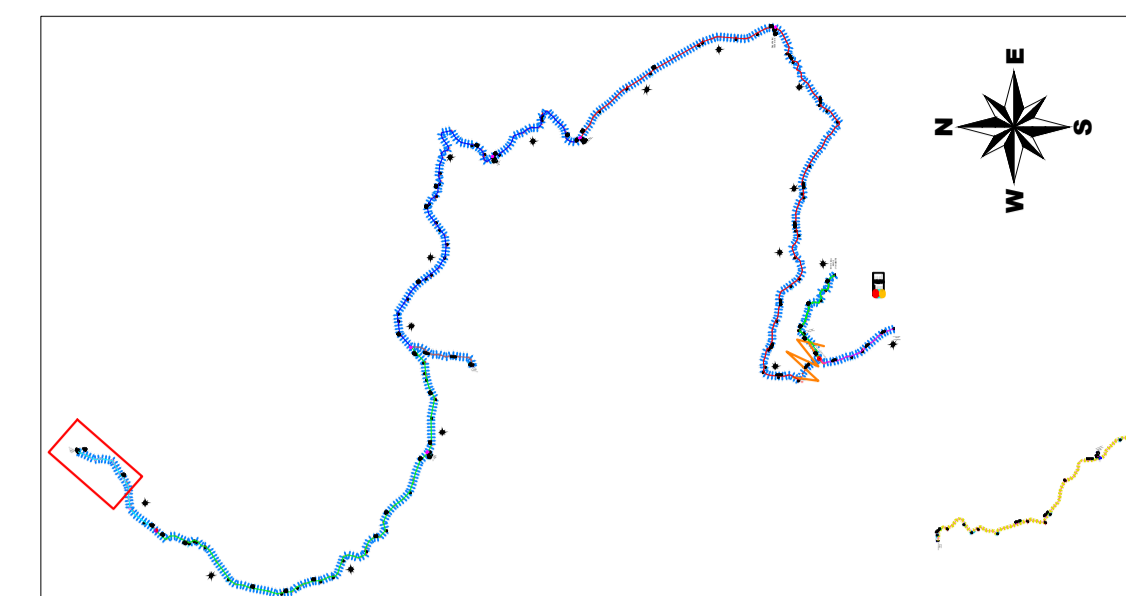

NUMRI PIKETES	349	350	351	352	353	354	355	356	357	358	359	360	361	362	363	364	365	366	367	368	369	370	371	372	373	374	375	376	377	378	379	380	381	382	
DISTANCA PARCIALE	129.5		33.1	14.8	20.5	14.4	41.7	118.6	28.1	71.3	20.0	21.4	23.3	29.5	30.9	45.2	79.8	39.0	62.6		36.3	50.1	783.4		37.3	17.3									
DISTANCA PROGRESIVE																																			
ELEMENTET HIDRAULIK	Q=9.22 l/s H=27.448 m OD 110 celik Sp14 V=1.654 m/s L=717 m																	Q=9.22 l/s H=27.448 m OD 110 celik Sp14 V=1.654 m/s L=717 m																	

**Investitor :**  
**BASHKIA POGRADEC**  
Adresa:  
Bulevardi "Reshit Collaku"  
Pogradec - Shqipëri  
Web: www.bashkiapogradec.al  
Email: bashkiapogradec@gmail.com



**Objekti:** "NDËRTIM UJËSJELLËSI RAJONAL TREBINJË - BURIMET E KOZICËS"  
Numri i projektit: **AL\_PG\_N\_U\_R\_T-B\_K**  
Vendodhja e projektit: **POGRADEC**

Grupi teknik i projektimit:  
**"ERALD-G" shpk Nr. Lic. N- 5304/11**  
Rruga "KONGRESI I LUSHNYES"  
Tirane  
eraldgshpk@yahoo.com  
Tel +355 4 357 970  
Cel +355 682090392

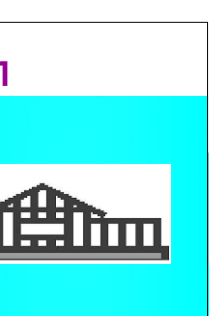

Administrator:  
**Gëzim ISLAMI**  
Inxhinier Konstruktor:  
**Gëzim ISLAMI** Lic. K-1196/6  
Inxhinier Hidroteknik:  
**Ersida VERCANI** Lic. K-1807/2

Arkitekt:  
**Elton CARCANI** Lic. A-0733/3  
Inxhinier Elektrik:  
**Hajdar KURTI** Lic. E-0180/5  
Inxhinier Topograf:  
**Kujtim CANAMETI** Lic. T-1058/3

Inxhinier Mekanik:  
**Arben MUHA** Lic. M-0308/3  
Inxhinier Gjeolog:  
**Leonard KAZANXHIU** Lic. GJ-0556/3  
Inxhinier Infrastruktura:  
**Gëzim ISLAMI** Lic. K-1196/6

Inxhinier Teknolog:  
**Ylber CANI**  
Inxhinier Mjedisit:  
**Nensi MEHMETI**  
Emërtimi i fletës:  
**PROFILI GJATESOR DEPO KALIVAC - DEPO PLESHISHT**

Faza e projektit:  
**Projekt Zbatimi**  
Formati: **A1**  
Shkalla: **SHV 1:100, SHH 1:1000**  
Nr i fletes: **P.GJ.18**  
Data: **2020**

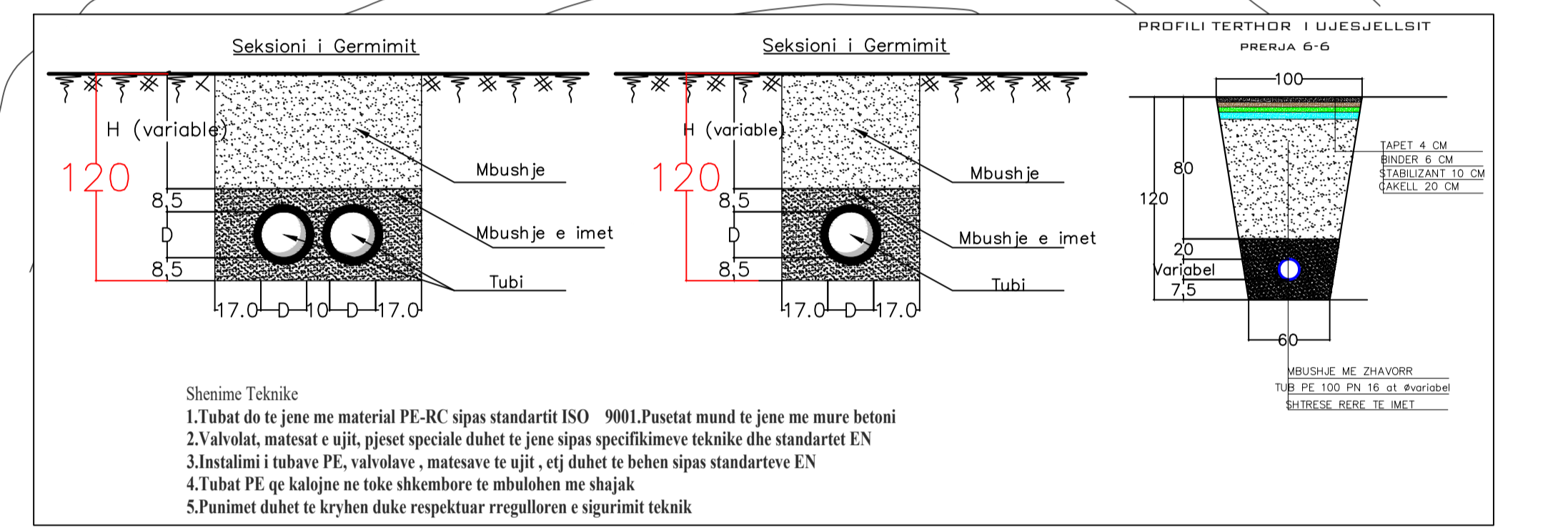
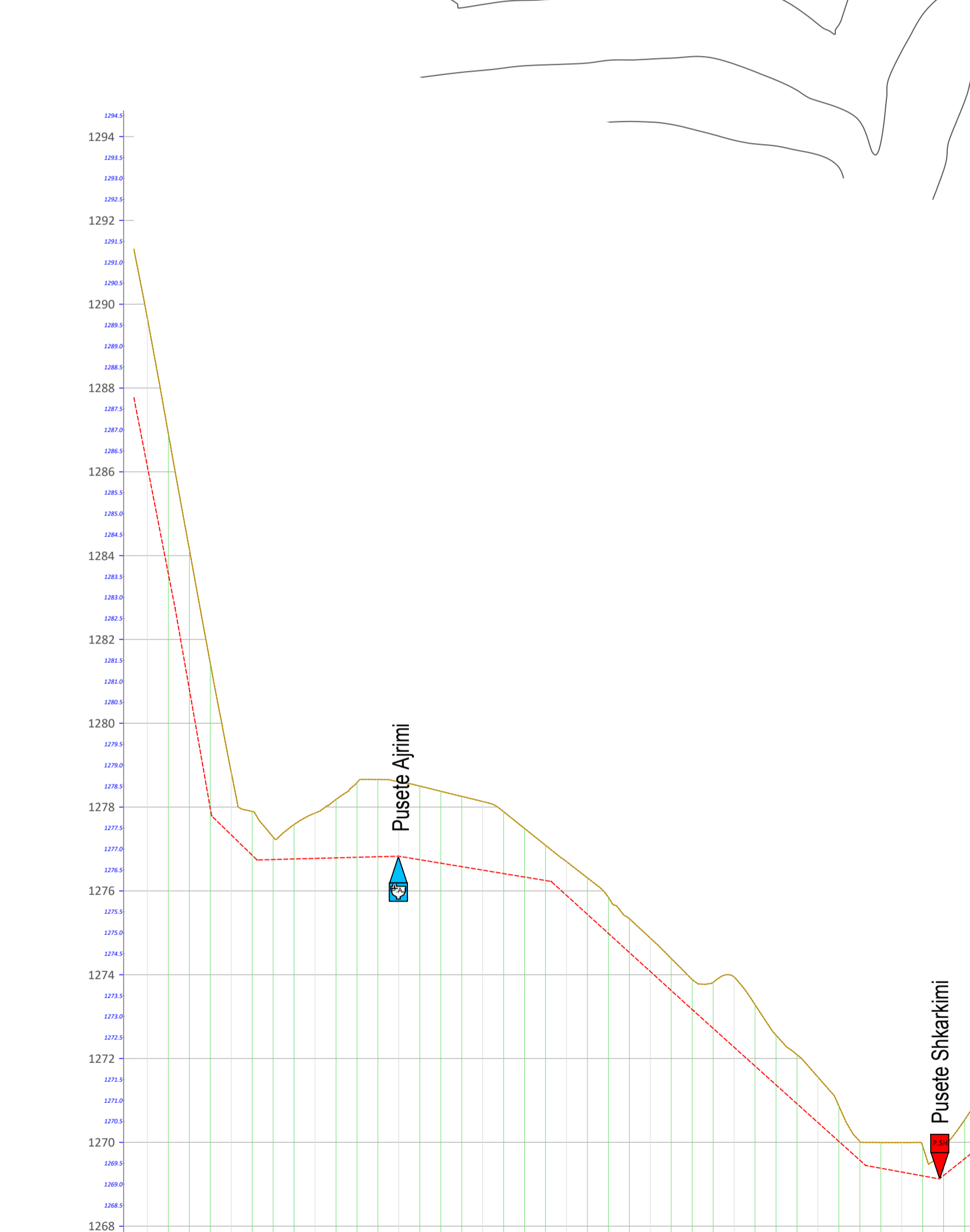
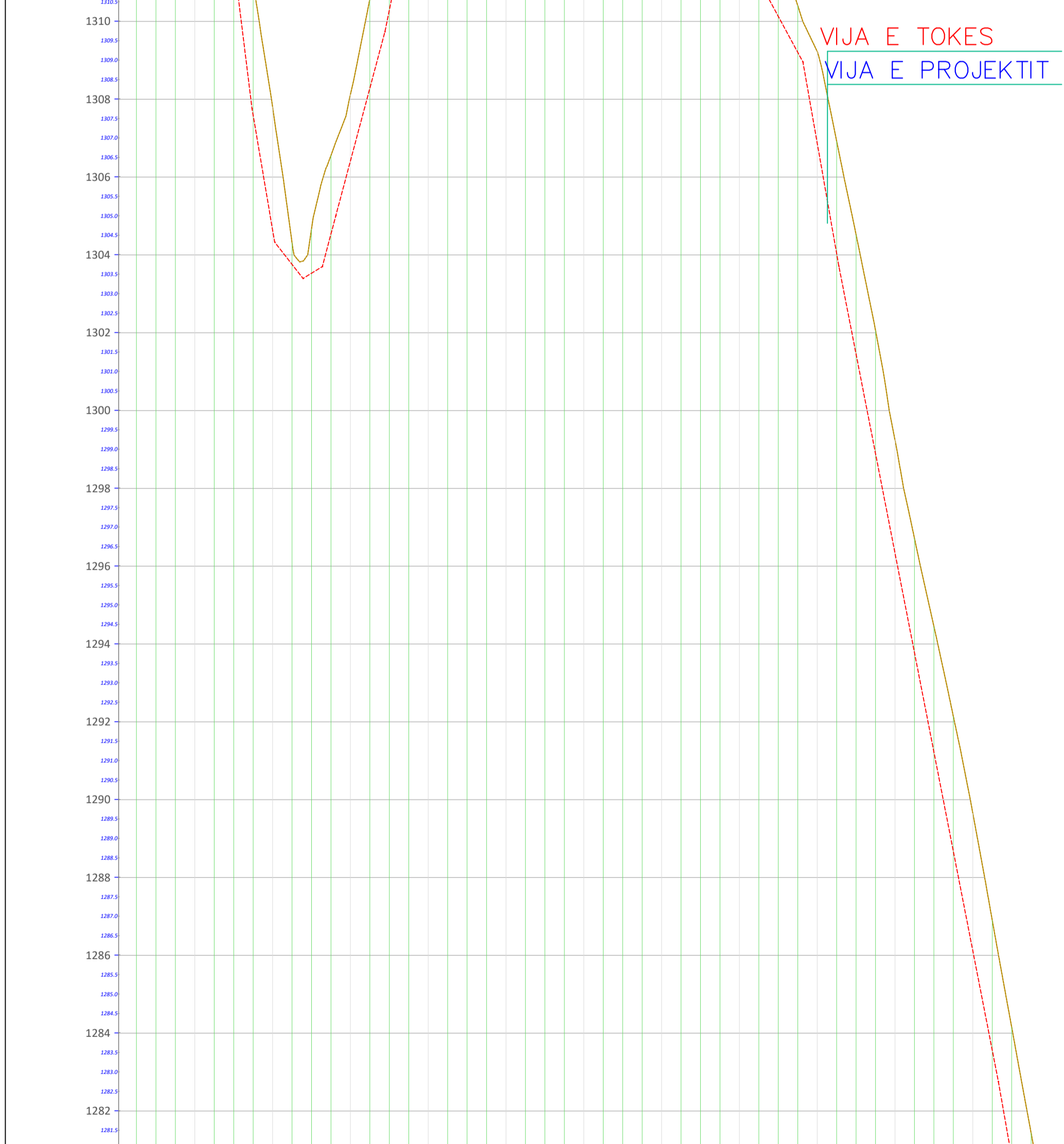
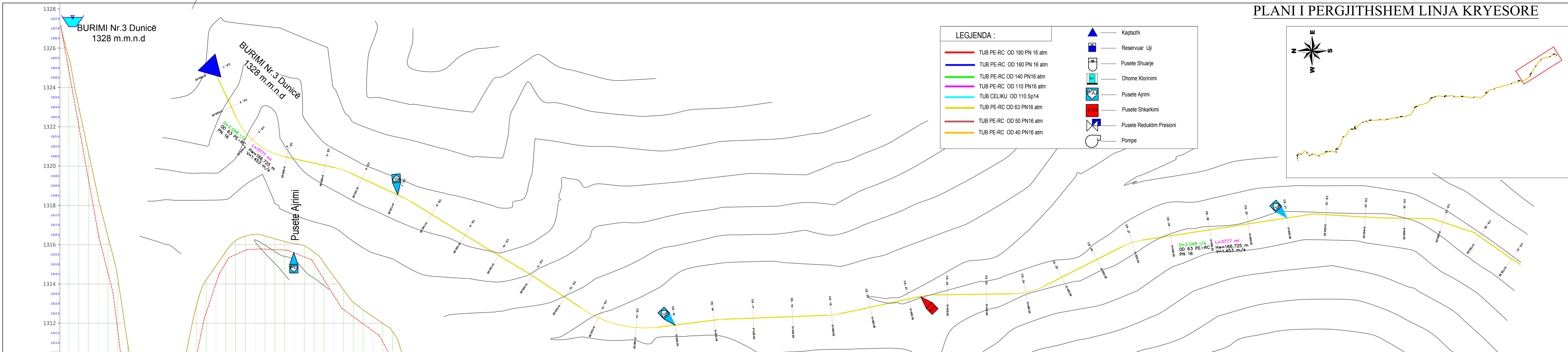

KUOTA TOKES	
KUOTA PROJEKTTIT	
DIST PROGRESIVE	
DIST PISORE	
NR I PËRUES	
KILOMETRAZHI	
ELEMENTET HIDRAULIK	$Q=2.048 \text{ l/s}$ OD 63 PE-RC PN 16 $L=3777 \text{ m}$ H=166,725 m V=1.453 m/s

KUOTA TOKES	
KUOTA PROJEKTTIT	
DIST PROGRESIVE	
DIST PISORE	
NR I PËRUES	
KILOMETRAZHI	
ELEMENTET HIDRAULIK	$Q=2.048 \text{ l/s}$ OD 63 PE-RC PN 16 $L=3777 \text{ m}$ H=166,725 m V=1.453 m/s

**Investitor :**  
**BASHKIA POGRADEC**  
 Adresa:  
 Bulevardi "Reshit Collaku"  
 Pogradec - Shqipëri  
 Web: www.bashkiapogradec.al  
 Email:bashkiapogradec@gmail.com



**Objekti: "NDËRTIM UJËSJELLËSI RAJONAL TREBINJË - BURIMET E KOZICËS"**

Numri i projektit: **AL\_PG\_N\_U\_R\_T-B\_K**  
 Vendodhja e projektit: **POGRADEC**

Grupi teknik i projektimit:  
**"ERALD-G" shpk Nr.lic. N- 5304/11**

Rruga "KONGRESI I LUSHNYES"  
 Tiranë  
 eraldgshpk@yahoo.com  
 Tel +355 4 357 970  
 Cel +355 682090392



Administrator:  
**Gëzim ISLAMI**

Inxhinier Konstruktor:  
**Gëzim ISLAMI** Lic. K-1196/6

Inxhinier Hidroteknik:  
**Ersida VERCANI** Lic. K-1807/2

Arkitekt:  
**Elton CARCANI** Lic. A-0733/3

Inxhinier Elektrik:  
**Hajdar KURTI** Lic. E-0180/5

Inxhinier Topograf:  
**Kujtim CANAMETI** Lic. T-1058/3

Inxhinier Mekanik:  
**Arben MUHA** Lic. M-0308/3

Inxhinier Gjeolog:  
**Leonard KAZANXHIU** Lic. GJ-0556/3

Inxhinier Infrastruktura:  
**Gëzim ISLAMI** Lic. K-1196/6

Inxhinier Teknolog:  
**Ylber CANI**  
 Inxhinier Mjedisit:  
**Nensi MEHMETI**

Emërtimi i fletës:  
**PROFILI GJATESOR BURIMI NR.3 - Guri i Bardhe**

Faza e projektit:  
**Projekt Zbatimi**

Formati: **A1**  
 Shkalla: **SHV 1:100, SHH 1:1000**

Nr i fletes: **P.GJ.19**

Data:  
**2020**

**LEGJENDA :**

	TUB PE-RC OD 180 PN 16 atm		Kapazhi
	TUB PE-RC OD 160 PN 16 atm		Reservuar Uji
	TUB PE-RC OD 140 PN16 atm		Pusete Shuarje
	TUB PE-RC OD 110 PN16 atm		Dhome Klorinimi
	TUB CELIKU OD 110 Sp14		Pusete Ajrimi
	TUB PE-RC OD 63 PN16 atm		Pusete Shkarkimi
	TUB PE-RC OD 50 PN16 atm		Pusete Reduktim Presioni
	TUB PE-RC OD 40 PN16 atm		Pompe

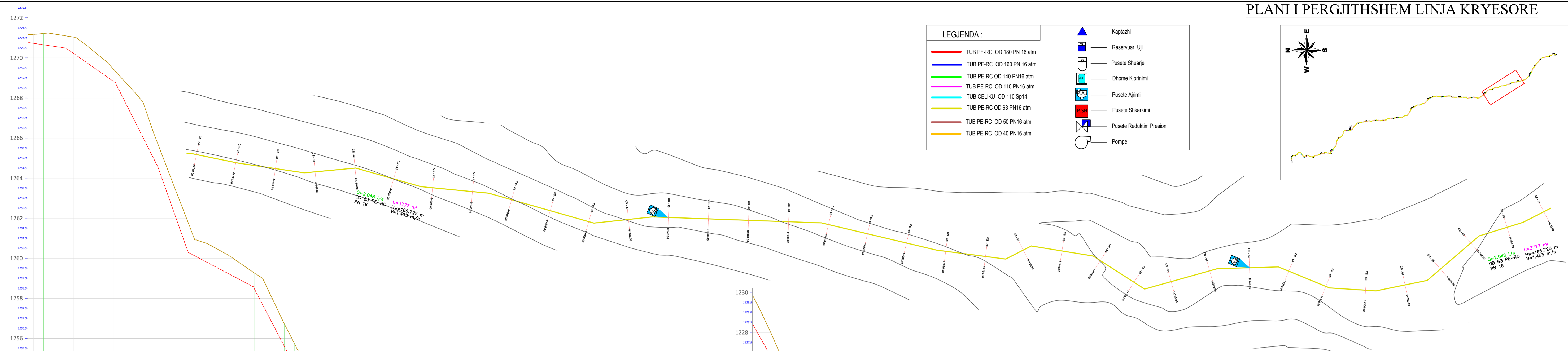
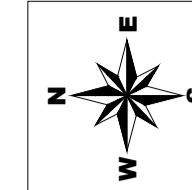

VIJA E TOKES  
VIJA E PROJEKTTIT

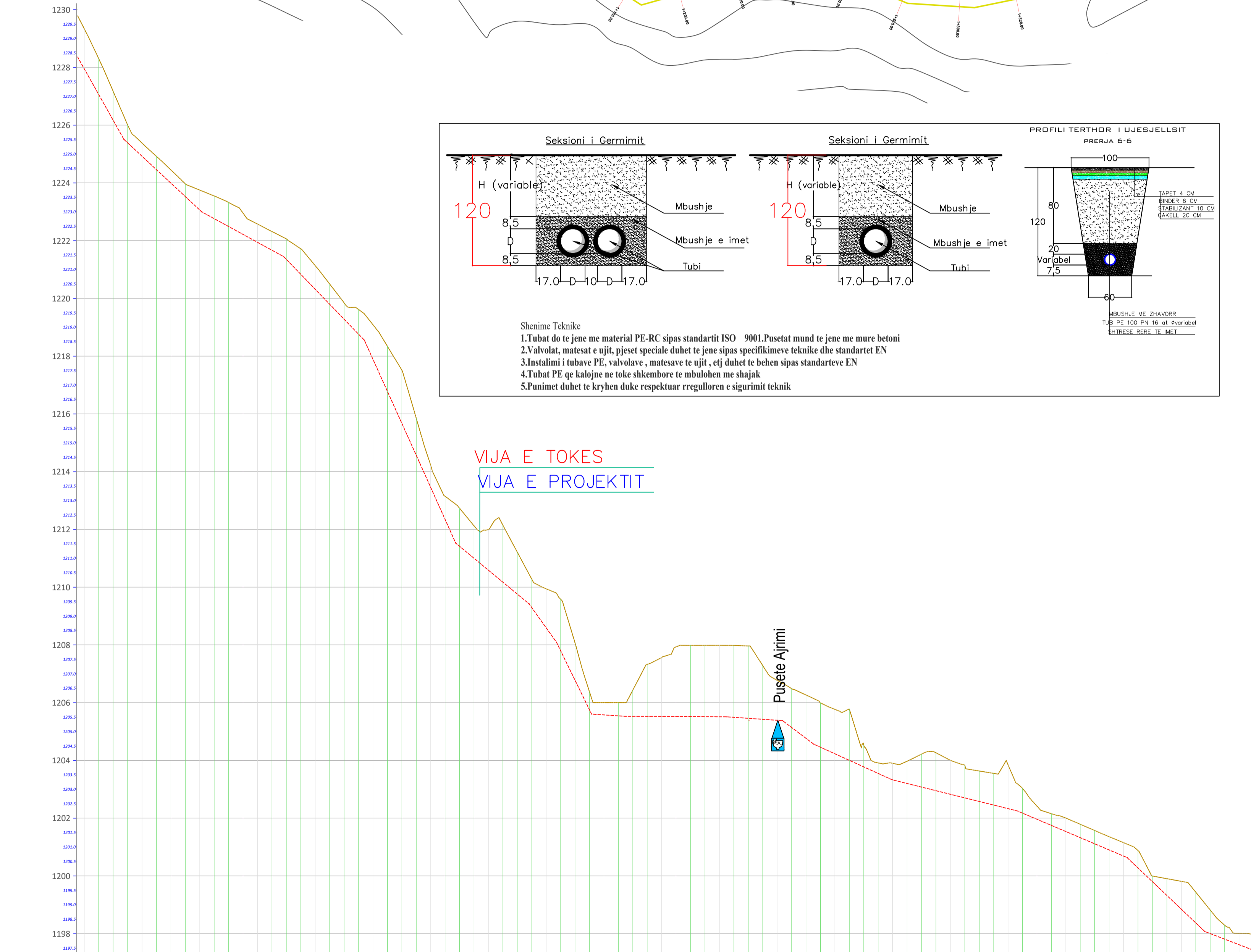
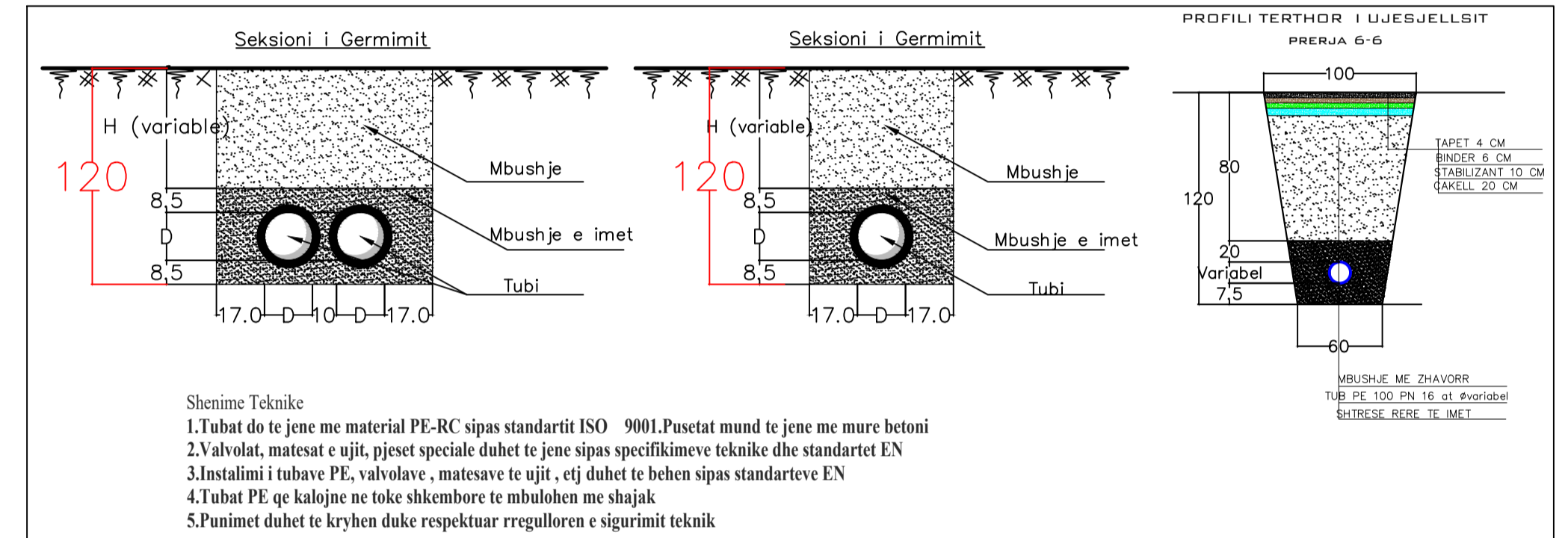

VIJA E TOKES  
VIJA E PROJEKTTIT

KUOTA TOKES	
KUOTA PROJEKTTIT	
DIST PROGRESIVE	
DIST PISORE	
NR I PIREJES	
KILOMETRAZHI	
ELEMENTET HIDRAULIK	Q=2,048 l/s OD 63 PE-RC PN 16 L=3777 m Hw=166,725 m V=1,453 m/s

KUOTA TOKES	
KUOTA PROJEKTTIT	
DIST PROGRESIVE	
DIST PISORE	
NR I PIREJES	
KILOMETRAZHI	
ELEMENTET HIDRAULIK	Q=2,048 l/s OD 63 PE-RC PN 16 L=3777 m Hw=166,725 m V=1,453 m/s

**Investitor :**  
**BASHKIA POGRADEC**  
Adresa:  
Bulevardi "Reshit Collaku"  
Pogradec - Shqipëri  
Web: www.bashkiapogradec.al  
Email:bashkiapogradec@gmail.com



**Objekti: "NDËRTIM UJËSJELLËSI  
RAJONAL TREBINJË - BURIMET  
E KOZICËS"**

Numri i projektit: **AL\_PG\_N\_U\_R\_T\_B\_K**  
Vendodhja e projektit: **POGRADEC**

Grupi teknik i projektimit:  
**"ERALD-G" shpk Nr. Lic. N- 5304/11**

Rruga "KONGRESI I LUSHNYES"  
Tirane  
eraldgshpk@yahoo.com  
Tel +355 4 357 970  
Cel +355 682090392



Administrator:  
**Gëzim ISLAMI**

Inxhinier Konstruktor:  
**Gëzim ISLAMI**  
Lic. K-1196/6

Inxhinier Hidroteknik:  
**Ersida VERCANI**  
Lic. K-1807/2

Arkitekt:  
**Eltan CARCANI** Lic. A-0733/3

Inxhinier Elektrik:  
**Hajdar KURTI** Lic. E-0180/5

Inxhinier Topograf:  
**Kujtim CANAMETI** Lic. T-1058/3

Inxhinier Mekanik:  
**Arben MUHA** Lic. M-0308/3

Inxhinier Gjeolog:  
**Leonard KAZANXHIU** Lic. GJ-0556/3

Inxhinier Infrastruktura:  
**Gëzim ISLAMI** Lic. K-1196/6

Inxhinier Teknolog:  
**Ylber CANI**  
Inxhinier Mjedisi:  
**Nensi MEHMETI**

Emërtimi i fletës:  
**PROFILI GJATESOR  
BURIMI NR.3 - Guri i Bardhe**

Faza e projektit:  
**Projekt Zbatimi**

Formati: **A1**  
Shkalla: SHV 1:100,  
SHH 1:1000

Nr i fletes: P.GJ.20

Data:  
**2020**

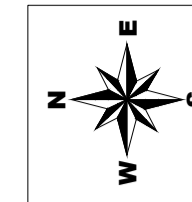

**LEGJENDA :**

	TUB PE-RC OD 180 PN 16 atm		Kapazhi
	TUB PE-RC OD 160 PN 16 atm		Reservuar Uji
	TUB PE-RC OD 140 PN16 atm		Pusete Shuarje
	TUB PE-RC OD 110 PN16 atm		Dhome Klorinimi
	TUB CELIKU OD 110 Sp14		Pusete Ajrimi
	TUB PE-RC OD 63 PN16 atm		Pusete Shkarkimi
	TUB PE-RC OD 50 PN16 atm		Pusete Reduktim Presioni
	TUB PE-RC OD 40 PN16 atm		Pompe

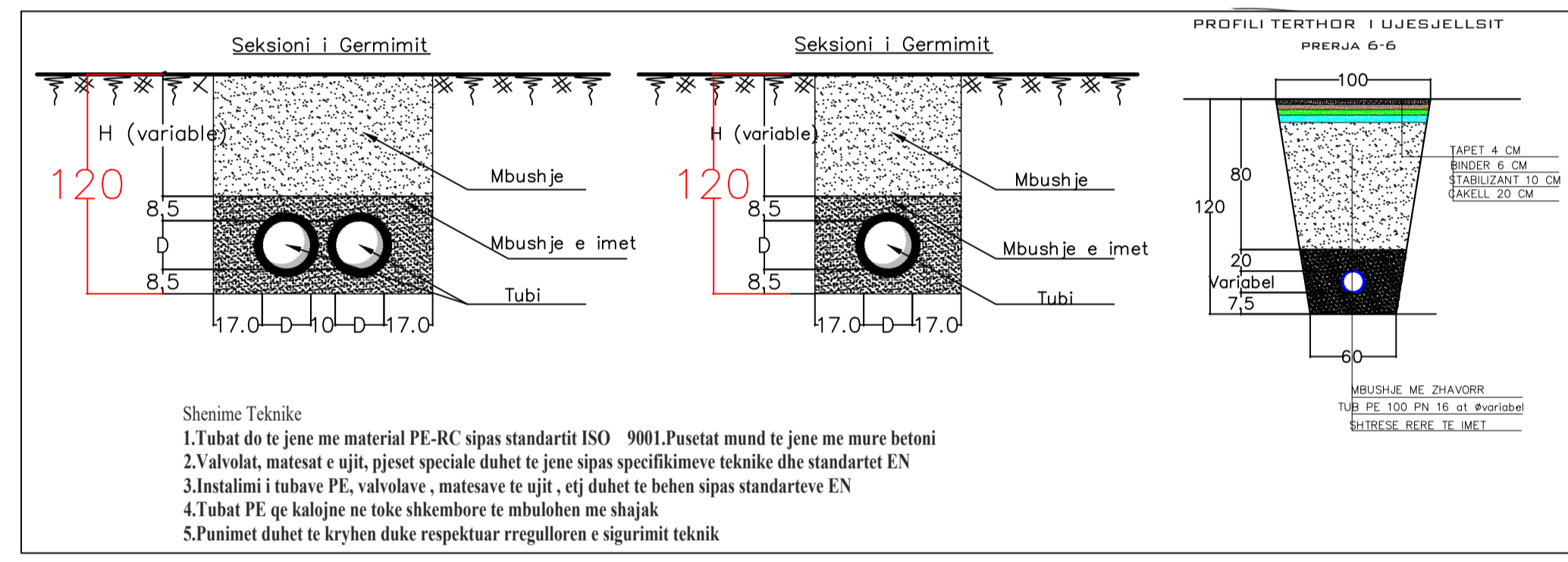
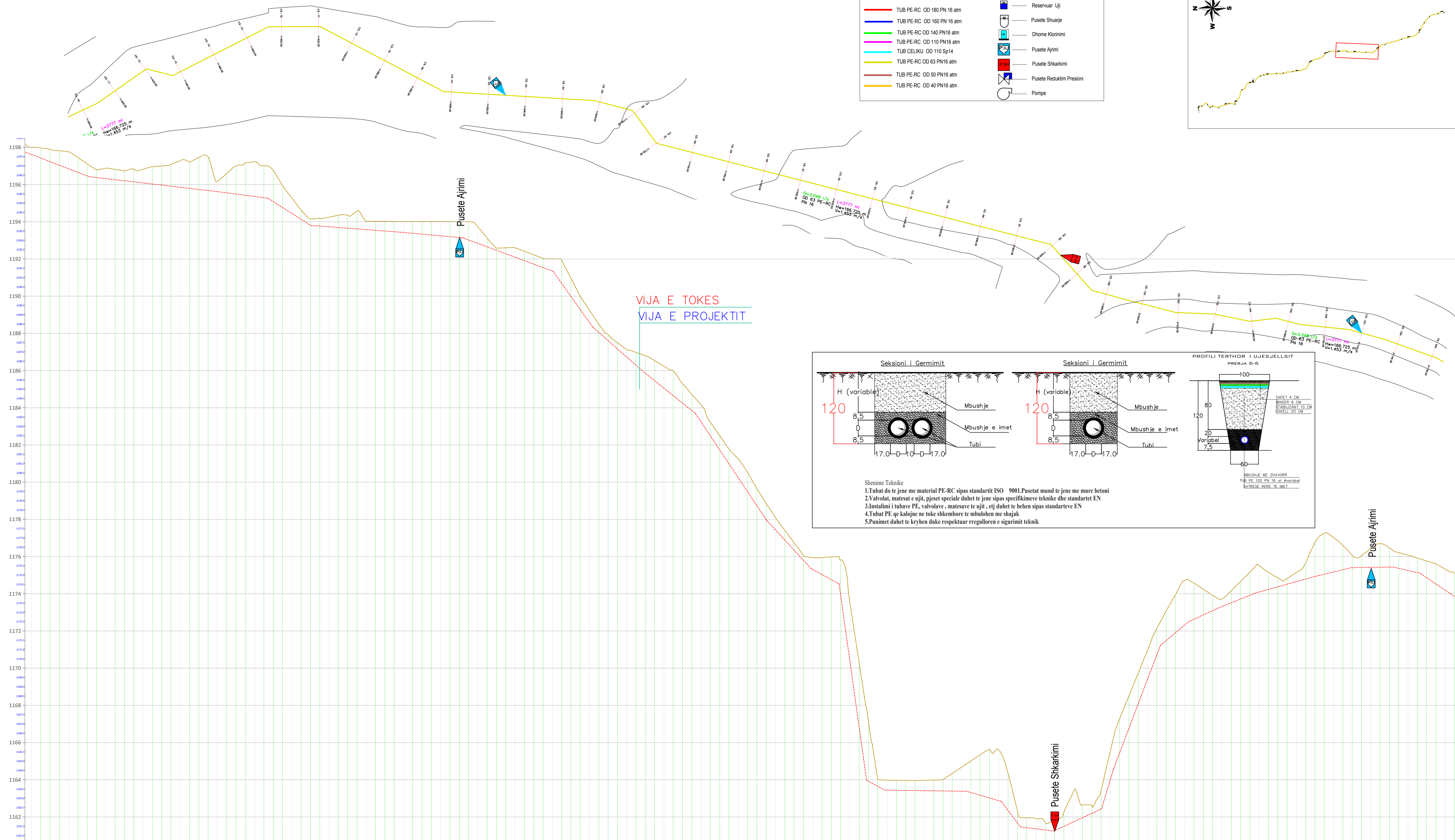

- Shenime Teknike**
1. Tubat do te jene me material PE-RC sipas standartit ISO 9001. Pusetat mund te jene me mure betoni
  2. Valvolat, matesat e ujit, pjeset speciale duhet te jene sipas specifikimeve teknike dhe standartet EN
  3. Instalimi i tubave PE, valvolave, matesave te ujit, etj duhet te behen sipas standarteve EN
  4. Tubat PE qe kalojne ne toke shkembore te mbulohen me shajak
  5. Punimet duhet te kryhen duke respektuar rregulloren e sigurimit tekanik

KUOTA TOKES	[Scale bar]																																																																																																			
KUOTA PROJEKTTIT	[Scale bar]																																																																																																			
DIST PROGRESIVE	[Scale bar]																																																																																																			
DIST PIESORE	[Scale bar]																																																																																																			
NR I PIERRES	[Scale bar]																																																																																																			
KILOMETRAZH	[Scale bar]																																																																																																			
ELEMENTET HIDRAULIK	<p>Q=2,048 l/s L=3777 m OD 63 PE-RC H=166,725 m PN 16 V=1,453 m/s</p> <p>Q=2,048 l/s L=3777 m OD 63 PE-RC H=166,725 m PN 16 V=1,453 m/s</p> <p>Q=2,048 l/s L=3777 m OD 63 PE-RC H=166,725 m PN 16 V=1,453 m/s</p>																																																																																																			

**Investitor :**  
**BASHKIA POGRADEC**  
Adresa:  
Bulevardi "Reshit Collaku"  
Pogradec - Shqipëri  
Web: www.bashkiapogradec.al  
Email: bashkiapogradec@gmail.com



**Objekti: "NDËRTIM UJËSJELLËSI RAJONAL TREBINJË - BURIMET E KOZICËS"**

Numri i projektit: **AL\_PG\_N\_U\_R\_T-B\_K**  
Vendodhja e projektit: **POGRADEC**

Grupi teknik i projektimit:  
**"ERALD-G" shpk Nr. Jic. N- 5304/11**

Ruga "KONGRESI I LUSHNJES"  
Tirane  
eraldgshpk@yahoo.com  
Tel +355 4 357 970  
Cel +355 682090392



Administrator:  
**Gëzim ISLAMI**

Inzhinier Konstruktor:  
**Gëzim ISLAMI** Lic. K-1196/6

Inzhinier Hidroteknik:  
**Ersida VERCANI** Lic. K-1807/2

Arkitekt:  
**Elton CARCANI** Lic. A-0733/3

Inzhinier Elektrik:  
**Hajdar KURTI** Lic. E-0180/5

Inzhinier Topograf:  
**Kujtim CANAMETI** Lic. T-1058/3

Inzhinier Mekanik:  
**Arben MUHA** Lic. M-0308/3

Inzhinier Gjeolog:  
**Leonard KAZANXHIU** Lic. GJ-0556/3

Inzhinier Infrastruktura:  
**Gëzim ISLAMI** Lic. K-1196/6

Inzhinier Teknolog:  
**Ylber CANI**  
Inzhinier Mjedisit:  
**Nensi MEHMETI**

Emërtimi i fletës:  
**PROFILI GJATESOR BURIMI NR.3 - Guri i Bardhe**

Faza e projektit:  
**Projekt Zbatimi**

Formati: **A1**  
Shkalla: **SHV 1:100, SHH 1:1000**

Nr i fletes: **P.GJ.21**

Data:  
**2020**

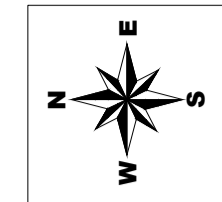

**LEGJENDA :**

	TUB PE-RC OD 180 PN 16 atm		Kapazhi
	TUB PE-RC OD 160 PN 16 atm		Reservuar Uji
	TUB PE-RC OD 140 PN16 atm		Pusete Shuarje
	TUB PE-RC OD 110 PN16 atm		Dhome Klorinimi
	TUB CELIKU OD 110 Sp14		Pusete Ajrimi
	TUB PE-RC OD 63 PN16 atm		Pusete Shkarkimi
	TUB PE-RC OD 50 PN16 atm		Pusete Reduktim Presioni
	TUB PE-RC OD 40 PN16 atm		Pompe

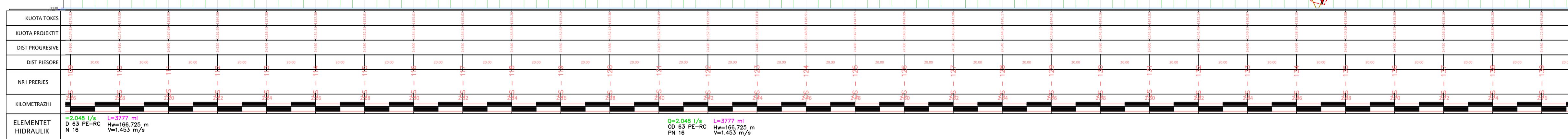
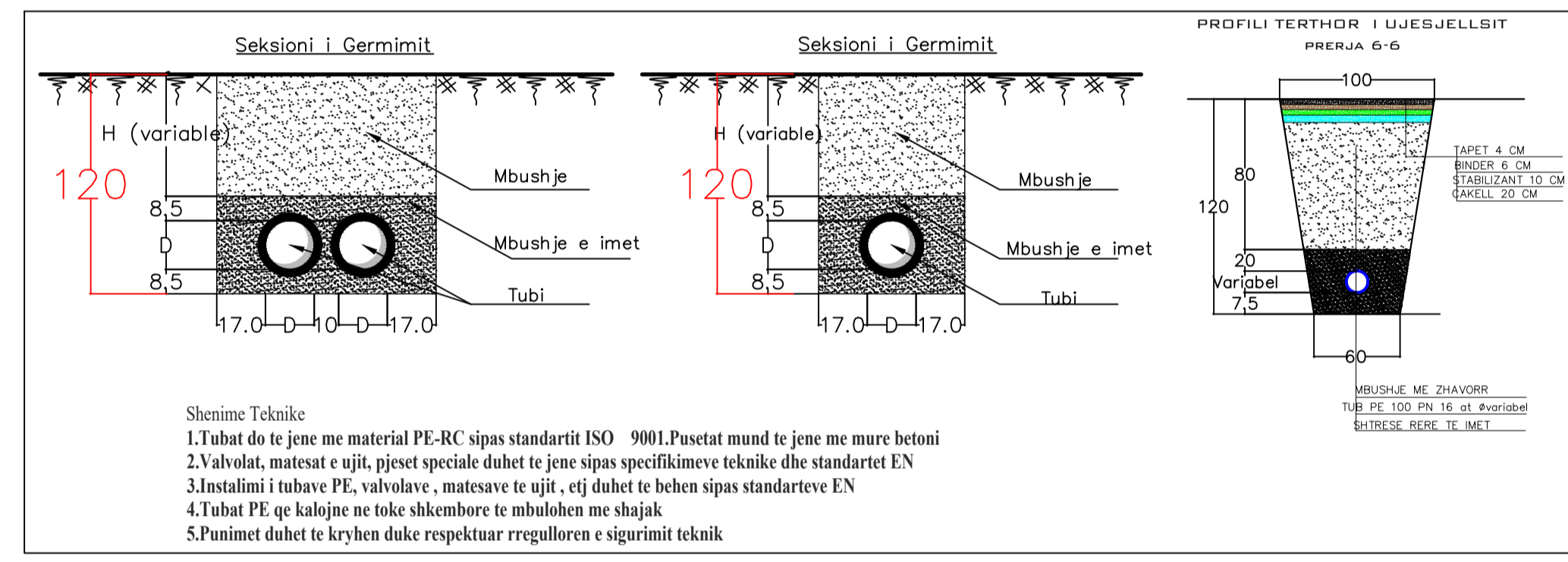
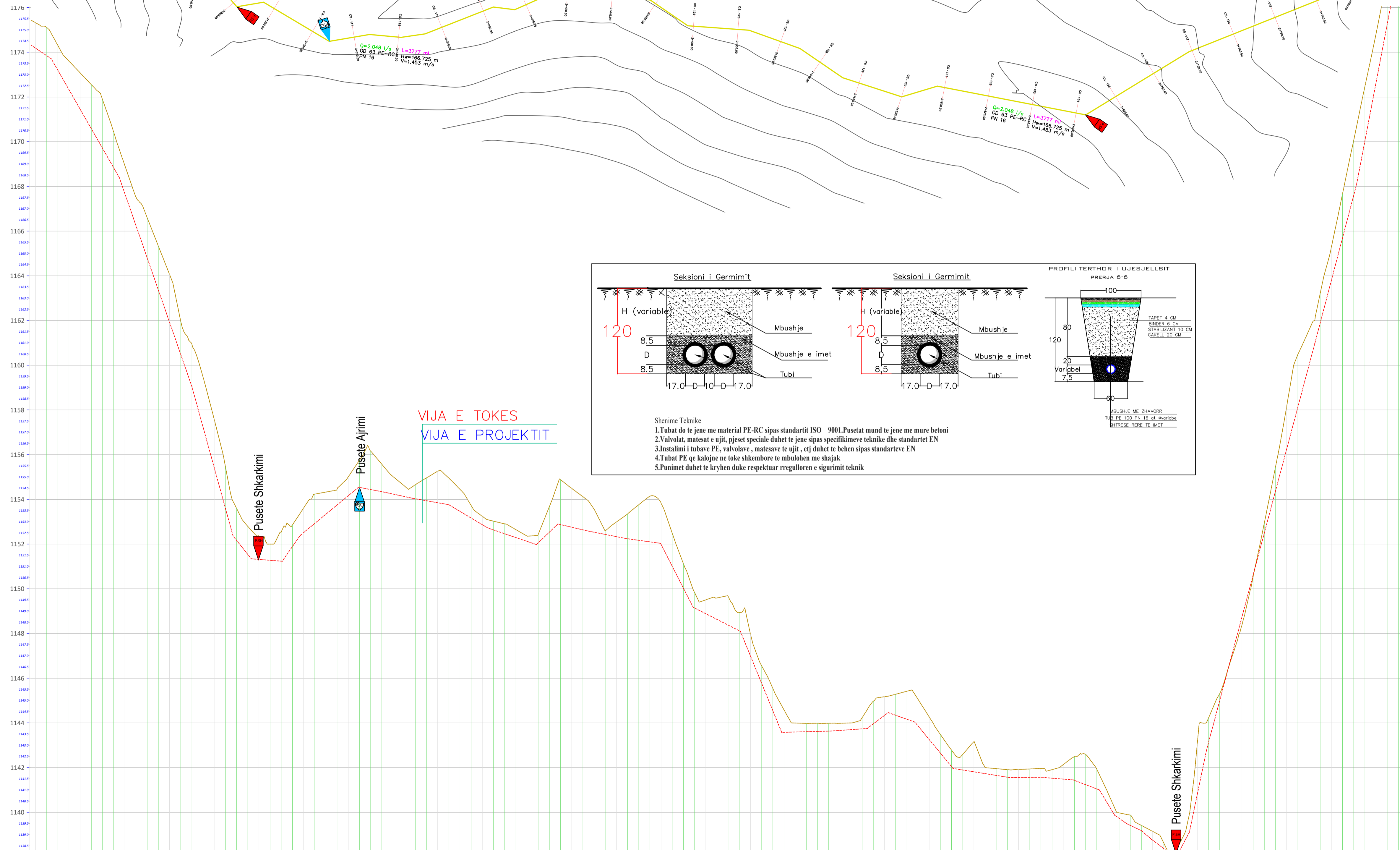

**Investitor :**  
**BASHKIA POGRADEC**  
Adresa:  
Bulevardi "Reshit Collaku"  
Pogradec - Shqipëri  
Web: www.bashkiapogradec.al  
Email:bashkiapogradec@gmail.com



**Objekti:** "NDËRTIM UJËSJELLËSI  
RAJONAL TREBINJË - BURIMET  
E KOZICËS"  
Numri i projektit: AL\_PG\_N\_U\_R\_T-B\_K  
Vendodhja e projektit: POGRADEC

Grupi teknik i projektimit:  
**"ERALD-G" shpk Nr. Lic. N- 5304/11**  
Rruga "KONGRESI I LUSHNYES"  
Tirane  
eraldgshpk@yahoo.com  
Tel +355 4 357 970  
Cel +355 682090392



Administrator:  
**Gëzim ISLAMI**  
Inxhinier Konstruktor:  
**Gëzim ISLAMI** Lic. K-1196/6  
Inxhinier Hidroteknik:  
**Ersida VERCANI** Lic. K-1807/2

Arkitekt:  
**Elton CARCANI** Lic. A-0733/3  
Inxhinier Elektrik:  
**Hajdar KURTI** Lic. E-0180/5  
Inxhinier Topograf:  
**Kujtim CANAMETI** Lic. T-1058/3

Inxhinier Mekanik:  
**Arben MUHA** Lic. M-0308/3  
Inxhinier Gjeolog:  
**Leonard KAZANXHIU** Lic. GJ-0556/3  
Inxhinier Infrastruktura:  
**Gëzim ISLAMI** Lic. K-1196/6

Inxhinier Teknolog:  
**Ylber CANI**  
Inxhinier Mjedisi:  
**Nensi MEHMETI**  
Emërtimi i fletës:  
**PROFILI GJATESOR**  
**BURIMI NR.3 - Guri i Bardhe**

Faza e projektit:  
**Projekt Zbatimi**  
Formati: **A1**  
Shkalla: SHV 1:100,  
SHH 1:1000  
Nr i fletes: P.GJ.22  
Data:  
**2020**

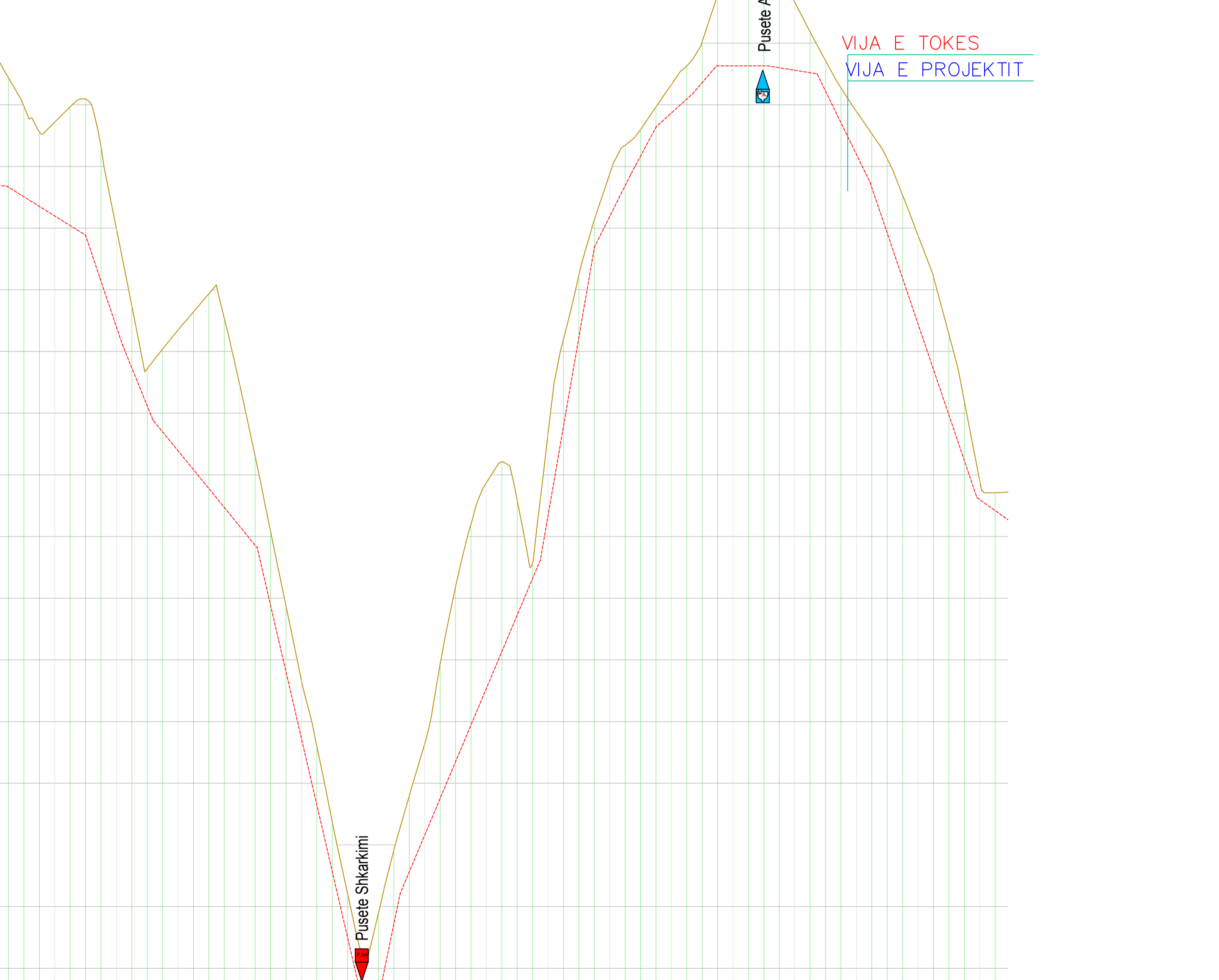
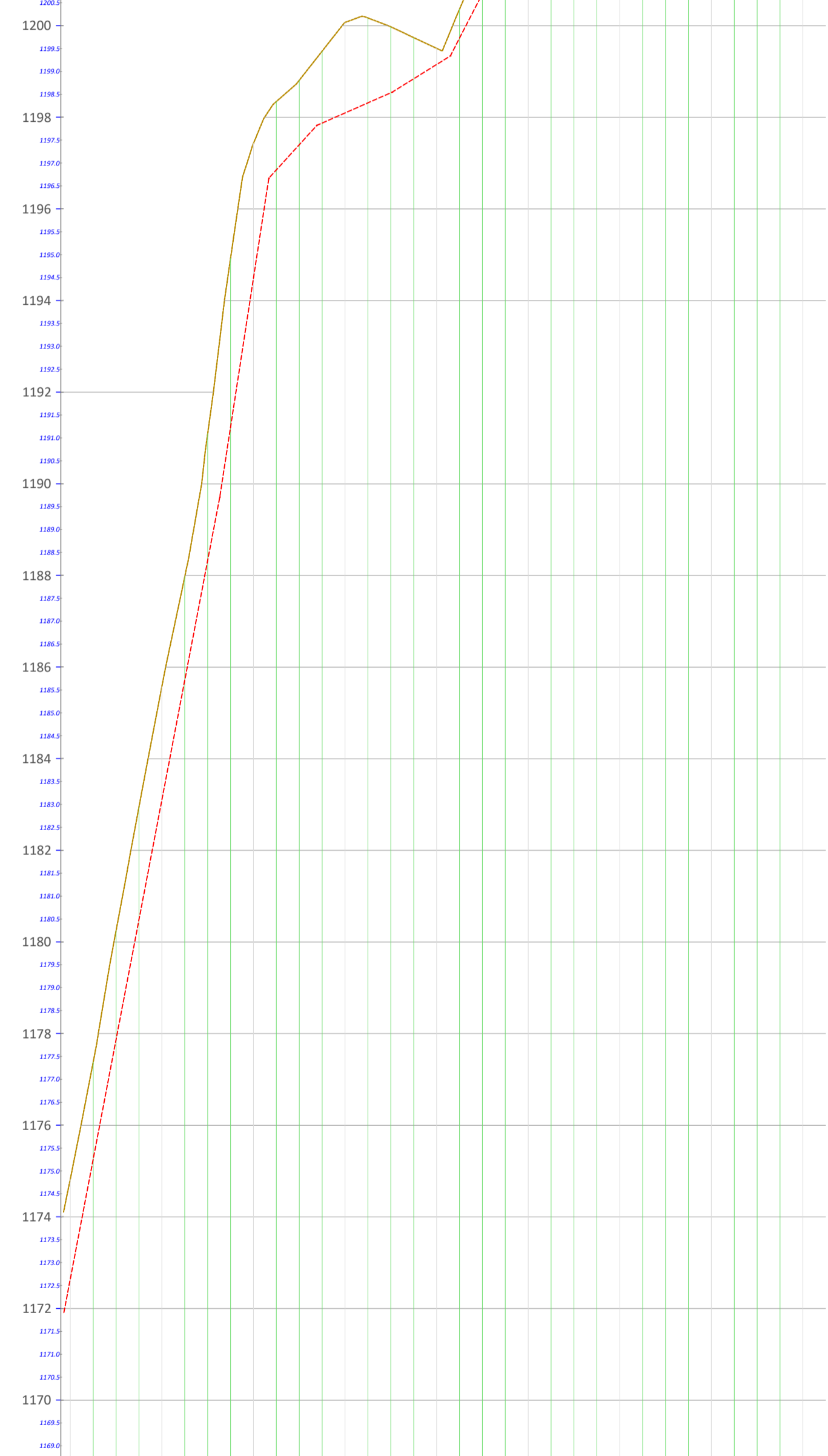
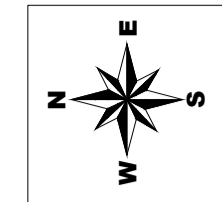
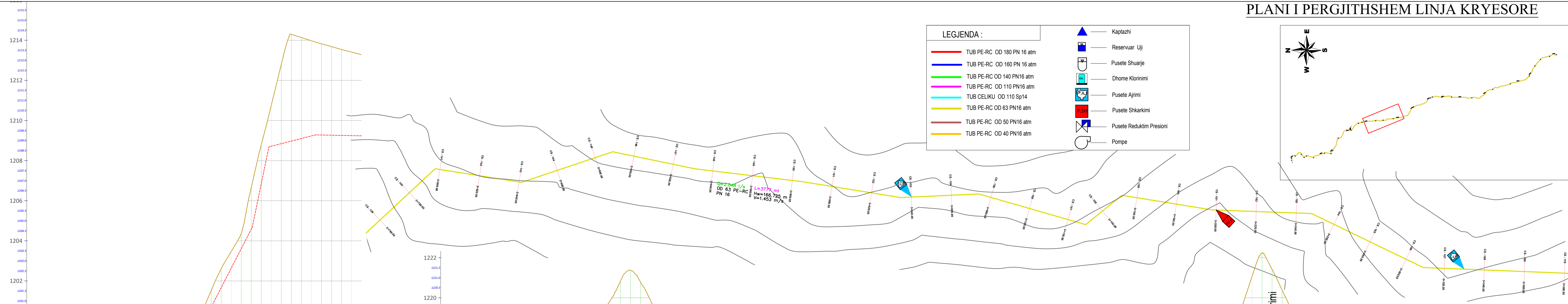

VIJA E TOKES  
VIJA E PROJEKTTIT

KUOTA TOKES	
KUOTA PROJEKTTIT	
DIST PROGRESIVE	
DIST PËSORE	
NR I PËRYES	
KILOMETRAZH	
ELEMENTET HIDRAULIK	Q=2,048 l/s OD 63 PE-RC PN 16 L=3777 m H=166,725 m V=1,453 m/s

KUOTA TOKES	
KUOTA PROJEKTTIT	
DIST PROGRESIVE	
DIST PËSORE	
NR I PËRYES	
KILOMETRAZH	
ELEMENTET HIDRAULIK	Q=2,048 l/s OD 63 PE-RC PN 16 L=3777 m H=166,725 m V=1,453 m/s

KUOTA TOKES	
KUOTA PROJEKTTIT	
DIST PROGRESIVE	
DIST PËSORE	
NR I PËRYES	
KILOMETRAZH	
ELEMENTET HIDRAULIK	Q=2,048 l/s OD 63 PE-RC PN 16 L=3777 m H=166,725 m V=1,453 m/s

**Investitor :**  
**BASHKIA POGRADEC**  
Adresa:  
Bulevardi "Reshit Collaku"  
Pogradec - Shqipëri  
Web: www.bashkiapogradec.al  
Email: bashkiapogradec@gmail.com



**Objekti: "NDËRTIM UJËSJELLËSI  
RAJONAL TREBINJË - BURIMET  
E KOZICËS"**  
Numri i projektit: \_\_\_\_\_ Vendodhja e projektit:  
**AL PG\_N\_U\_R\_T-B\_K POGRADEC**

Grupi teknik i projektimit:  
**"ERALD-G" shpk Nr. Lic. N- 5304/11**  
Rruga "KONGRESI I LUSHNJES"  
Tirane  
eraldgshpk@yahoo.com  
Tel +355 4 357 970  
Cel +355 682090392



Administrator:  
**Gëzim ISLAMI**  
Inxhinier Konstruktor:  
**Gëzim ISLAMI** Lic. K-1196/6  
Inxhinier Hidroteknik:  
**Ersida VERCANI** Lic. K-1807/2

Arkitekt:  
**Eltan CARCANI** Lic. A-0733/3  
Inxhinier Elektrik:  
**Hajdar KURTI** Lic. E-0180/5  
Inxhinier Topograf:  
**Kujtim CANAMETI** Lic. T-1058/3

Inxhinier Mekanik:  
**Arben MUHA** Lic. M-0308/3  
Inxhinier Gjeolog:  
**Leonard KAZANXHIU** Lic. GJ-0556/3  
Inxhinier Infrastruktura:  
**Gëzim ISLAMI** Lic. K-1196/6

Inxhinier Teknolog:  
**Ylber CANI**  
Inxhinier Mjedisit:  
**Nensi MEHMETI**  
Emërtimi i fletës:  
**PROFILI GJATESOR  
BURIMI NR.3 - Guri i Bardhe**

Faza e projektit:  
**Projekt Zbatimi**  
Formati: **A1**  
Shkalla: SHV 1:100,  
SHH 1:1000  
Nr i fletes: P.GJ.23  
Data:  
**2020**

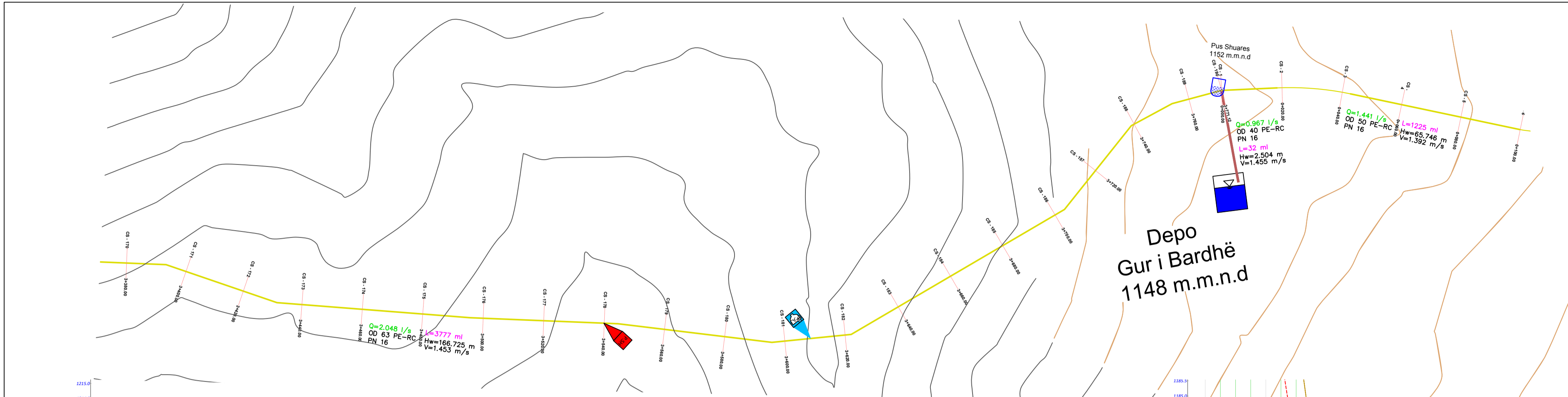

LEGJENDA:

<span style="color: red;">—</span>	TUB PE-RC OD 180 PN 16 atm		Kaptazhi
<span style="color: blue;">—</span>	TUB PE-RC OD 160 PN 16 atm		Reservuar Uj
<span style="color: green;">—</span>	TUB PE-RC OD 140 PN 16 atm		Pusete Shuarje
<span style="color: magenta;">—</span>	TUB PE-RC OD 110 PN 16 atm		Dhome Klorinimi
<span style="color: cyan;">—</span>	TUB CELIKU OD 110 Sp14		Pusete Ajrimi
<span style="color: yellow;">—</span>	TUB PE-RC OD 63 PN 16 atm		Pusete Shkarkimi
<span style="color: brown;">—</span>	TUB PE-RC OD 50 PN 16 atm		Pusete Redukim Presioni
<span style="color: orange;">—</span>	TUB PE-RC OD 40 PN 16 atm		Pompe

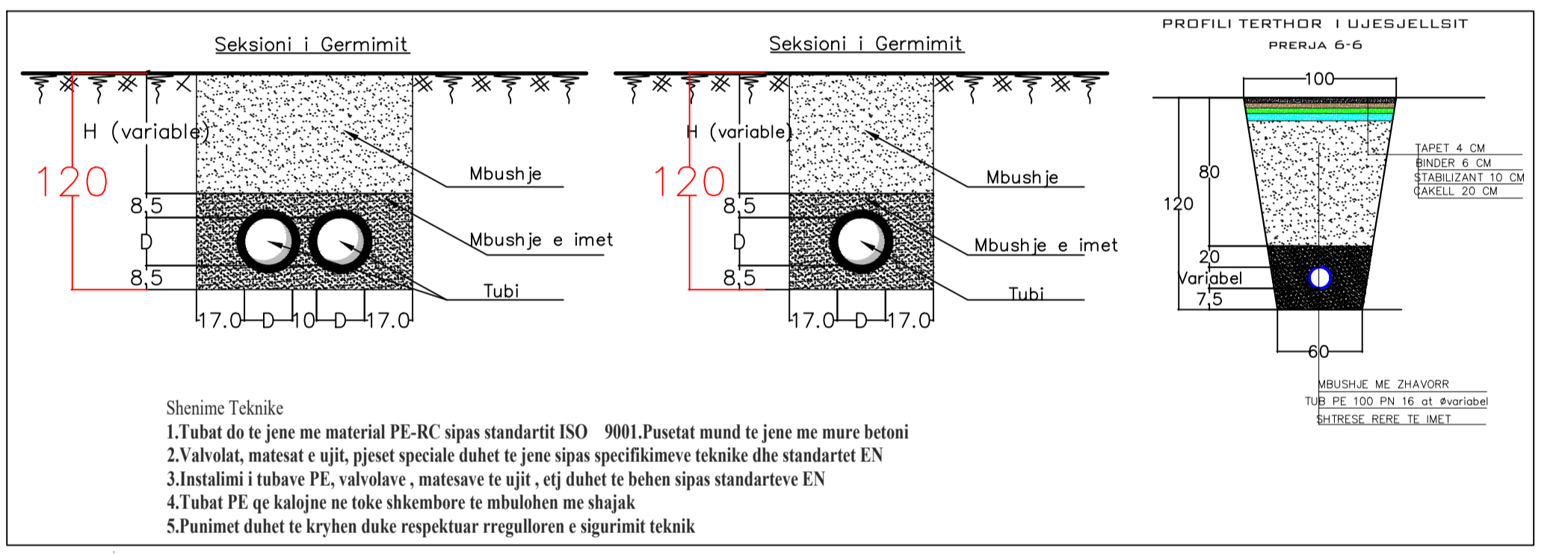
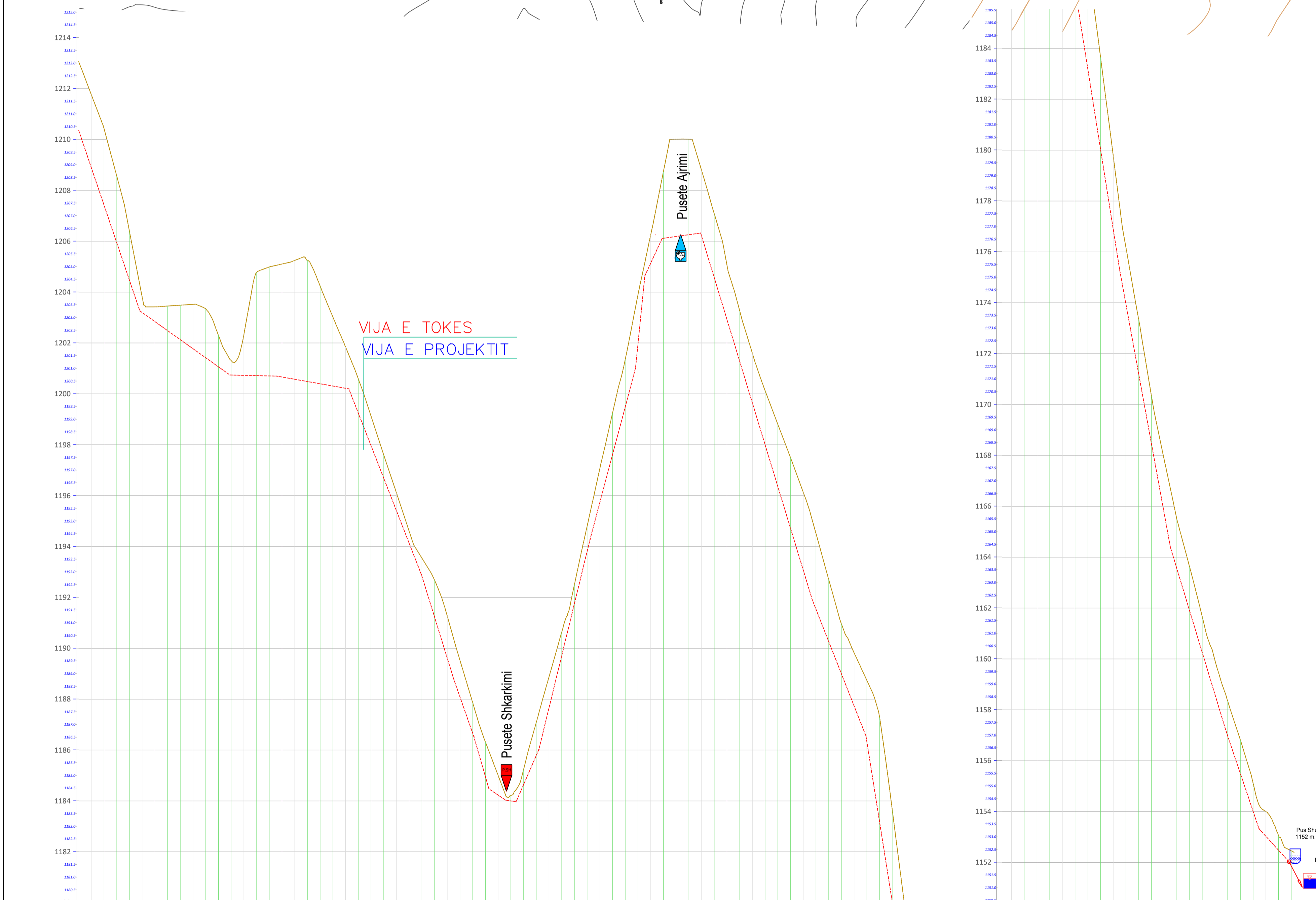
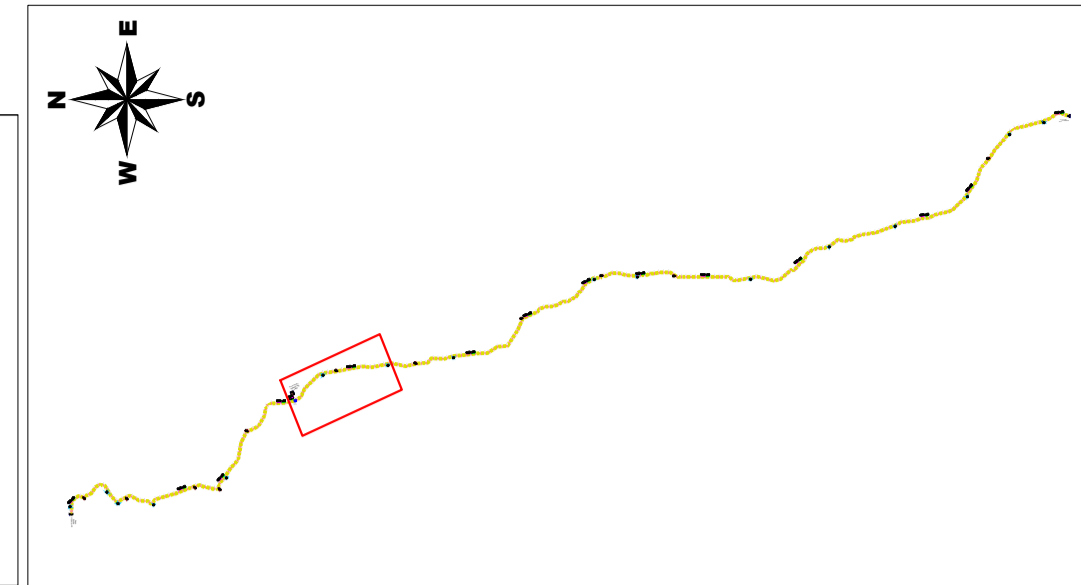

- Shtime Teknike
- 1.Tubat do te jene me material PE-RC sipas standartit ISO 9001.Pusetat mund te jene me mure betoni
  - 2.Valvolat, matesat e ujit, pjeset speciale duhet te jene sipas specifikimeve teknike dhe standartet EN
  - 3.Instalimi i tubave PE, valvolave , matesave te ujit , etj duhet te behen sipas standarteve EN
  - 4.Tubat PE qe kalojne ne toke shkembon te mbulohen me shajak
  - 5.Punimet duhet te kryhen duke respektuar rregulloren e sigurimit teknik

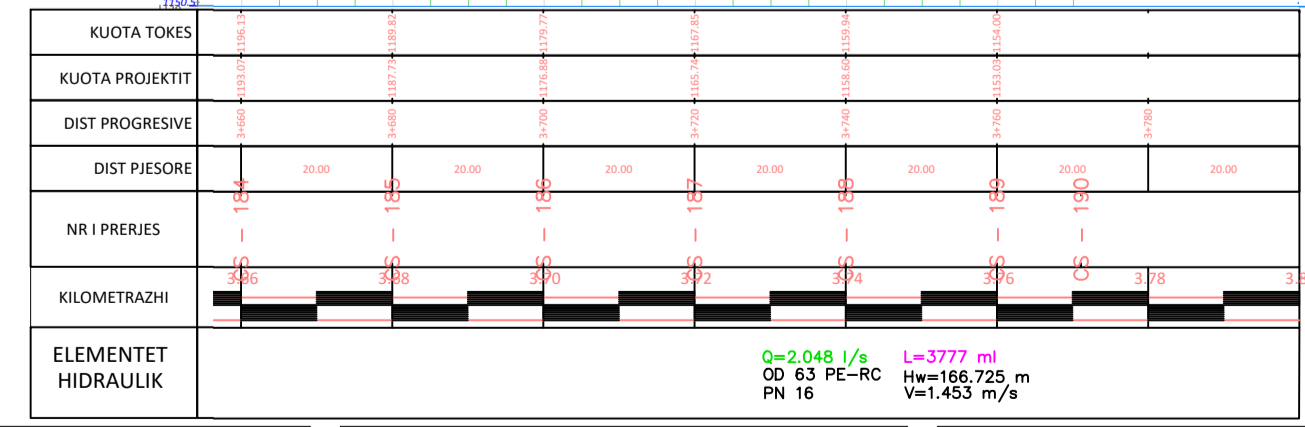
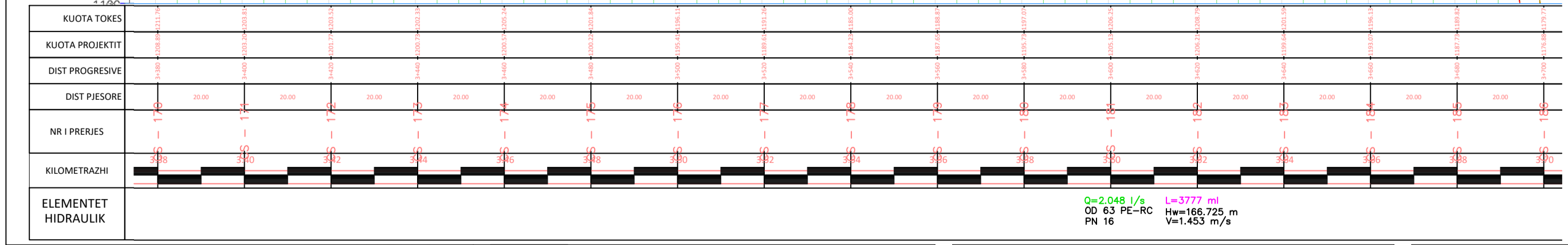

**Investitor :**  
**BASHKIA POGRADEC**  
 Adresa:  
 Bulevardi "Reshit Collaku"  
 Pogradec - Shqipëri  
 Web: www.bashkiapogradec.al  
 Email:bashkiapogradec@gmail.com



**Objekti:** "NDËRTIM UJËSJELLËSI RAJONAL TREBINJË - BURIMET E KOZICËS"  
 Numri i projektit: AL\_PG\_N\_U\_R\_T-B\_K  
 Vendodhja e projektit: POGRADEC

Grupi teknik i projektimit:  
**"ERALD-G" shpk Nr.Jic. N- 5304/11**  
 Rruga "KONGRESI I LUSHNYES"  
 Tirane  
 eraldgshpk@yahoo.com  
 Tel +355 4 357 970  
 Cel +355 682090392



Administrator:  
**Gëzim ISLAMI**  
 Inxhinier Konstruktor:  
**Gëzim ISLAMI**  
 Inxhinier Hidroteknik:  
**Ersida VERGANI**  
 Lic. K-1196/6  
 Lic. K-1807/2

Arkitekt:  
**Eltan CARCANI**  
 Lic. A-0733/3  
 Inxhinier Elektrik:  
**Hajdar KURTI**  
 Lic. E-0180/5  
 Inxhinier Topograf:  
**Kujtim CANAMETI**  
 Lic. T-1058/3

Inxhinier Mekanik:  
**Arben MUHA**  
 Lic. M-0308/3  
 Inxhinier Gjeolog:  
**Leonard KAZANXHIU**  
 Lic. GJ-0556/3  
 Inxhinier Infrastrukturate:  
**Gëzim ISLAMI**  
 Lic. K-1196/6

Inxhinier Teknolog:  
**Ylber CANI**  
 Inxhinier Mjedisit:  
**Nensi MEHMETI**  
 Emërtimi i fletës:  
**PROFILI GJATESOR BURIMI NR.3 - Guri i Bardhe**

Faza e projektit:  
**Projekt Zbatimi**  
 Formati: A1  
 Shkalla: SHV 1:100, SHH 1:1000  
 Nr i fletes: P.GJ.24  
 Data: 2020



**LEGJENDA :**

	TUB PE-RC OD 180 PN 16 atm		Kaptazi
	TUB PE-RC OD 160 PN 16 atm		Reservuar Uji
	TUB PE-RC OD 140 PN16 atm		Pusete Shuarje
	TUB PE-RC OD 110 PN16 atm		Dhome Klorinimi
	TUB CELIKU OD 110 Sp14		Pusete Ajrimi
	TUB PE-RC OD 63 PN16 atm		Pusete Shkarkimi
	TUB PE-RC OD 50 PN16 atm		Pusete Reduktim Presioni
	TUB PE-RC OD 40 PN16 atm		Pompe

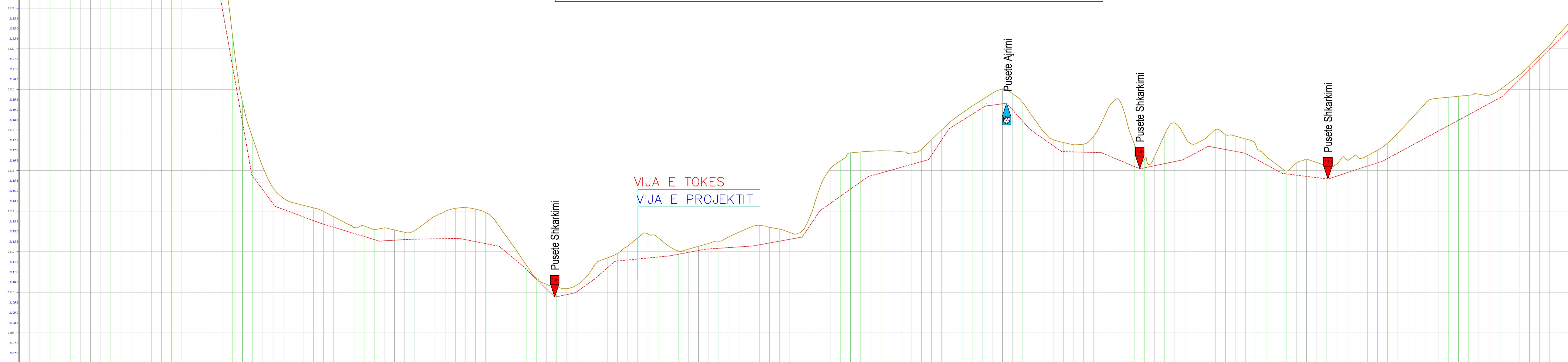
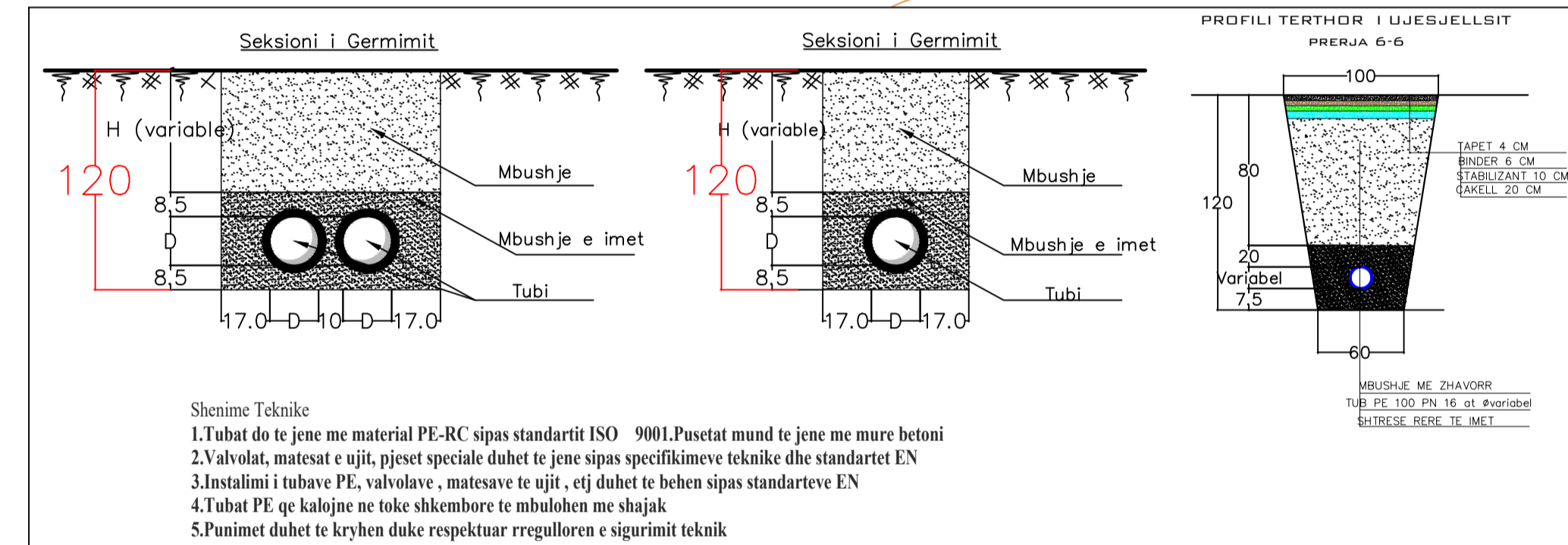
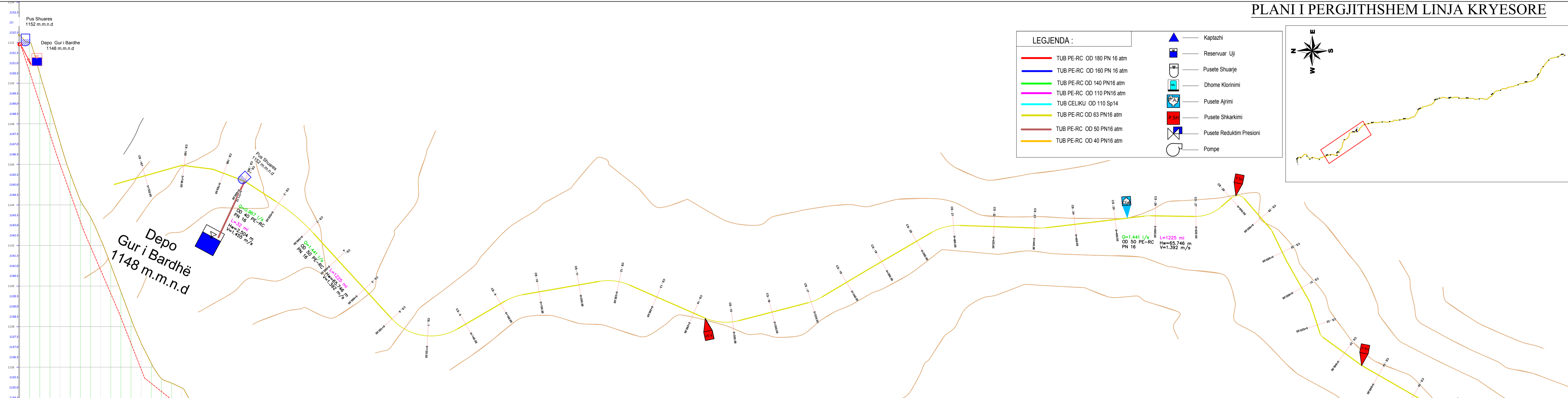
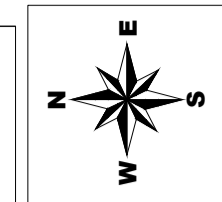

KUOTA TOKES	
KUOTA PROJEKTI	
DIST PROGRESIVE	
DIST PËSORE	
NR I PËRYES	
KILOMETRAZH	
ELEMENTET HIDRAULIK	<p>Q=1.441 l/s L=1225 m OD 50 PE-RC Hw=65.746 m V=1.392 m/s</p> <p>Q=1.441 l/s L=1225 m OD 50 PE-RC Hw=65.746 m V=1.392 m/s</p> <p>Q=1.441 l/s L=1225 m OD 50 PE-RC Hw=65.746 m V=1.392 m/s</p>

**Investitor :**  
**BASHKIA POGRADEC**  
Adresa:  
Bulevardi "Reshit Collaku"  
Pogradec - Shqipëri  
Web: www.bashkiapogradec.al  
Email: bashkiapogradec@gmail.com



**Objekti:** "NDËRTIM UJËSJELLËSI  
RAJONAL TREBINJË - BURIMET  
E KOZICËS"  
Numri i projektit: **AL\_PG\_N\_U\_R\_T-B\_K**  
Vendodhja e projektit: **POGRADEC**

Grupi teknik i projektimit:  
**"ERALD-G" shpk Nr. Lic. N- 5304/11**  
Rruga "KONGRESI I LUSHNJES"  
Tirane  
eraldgshpk@yahoo.com  
Tel +355 4 357 970  
Cel +355 682090392



Administrator:  
**Gëzim ISLAMI**  
Inxhinier Konstruktor:  
**Gëzim ISLAMI** Lic. K-1196/6  
Inxhinier Hidroteknik:  
**Ersida VERCANI** Lic. K-1807/2

Arkitekt:  
**Elton CARCANI** Lic. A-0733/3  
Inxhinier Elektrik:  
**Hajdar KURTI** Lic. E-0180/5  
Inxhinier Topograf:  
**Kujtim CANAMETI** Lic. T-1058/3

Inxhinier Mekanik:  
**Arben MUHA** Lic. M-0308/3  
Inxhinier Gjeolog:  
**Leonard KAZANXHIU** Lic. GJ-0556/3  
Inxhinier Infrastruktura:  
**Gëzim ISLAMI** Lic. K-1196/6

Inxhinier Teknolog:  
**Ylber CANI**  
Inxhinier Mjedis:  
**Nensi MEHMETI**  
Emërtimi i fletës:  
**PROFILI GJATESOR**  
**Depo Gur i Bardhe - Dunice**

Faza e projektit:  
**Projekt Zbatimi**  
Formati: **A1**  
Shkalla: **SHV 1:100, SHH 1:1000**  
Nr i fletes: **P.GJ.25**  
Data:  
**2020**

**LEGJENDA :**

	TUB PE-RC OD 180 PN 16 atm		Kaptazi
	TUB PE-RC OD 160 PN 16 atm		Reservuar Uji
	TUB PE-RC OD 140 PN16 atm		Pusete Shuarje
	TUB PE-RC OD 110 PN16 atm		Dhome Klorinimi
	TUB CELIKU OD 110 Sp14		Pusete Ajrimi
	TUB PE-RC OD 63 PN16 atm		Pusete Shkarkimi
	TUB PE-RC OD 50 PN16 atm		Pusete Redukim Presioni
	TUB PE-RC OD 40 PN16 atm		Pompe

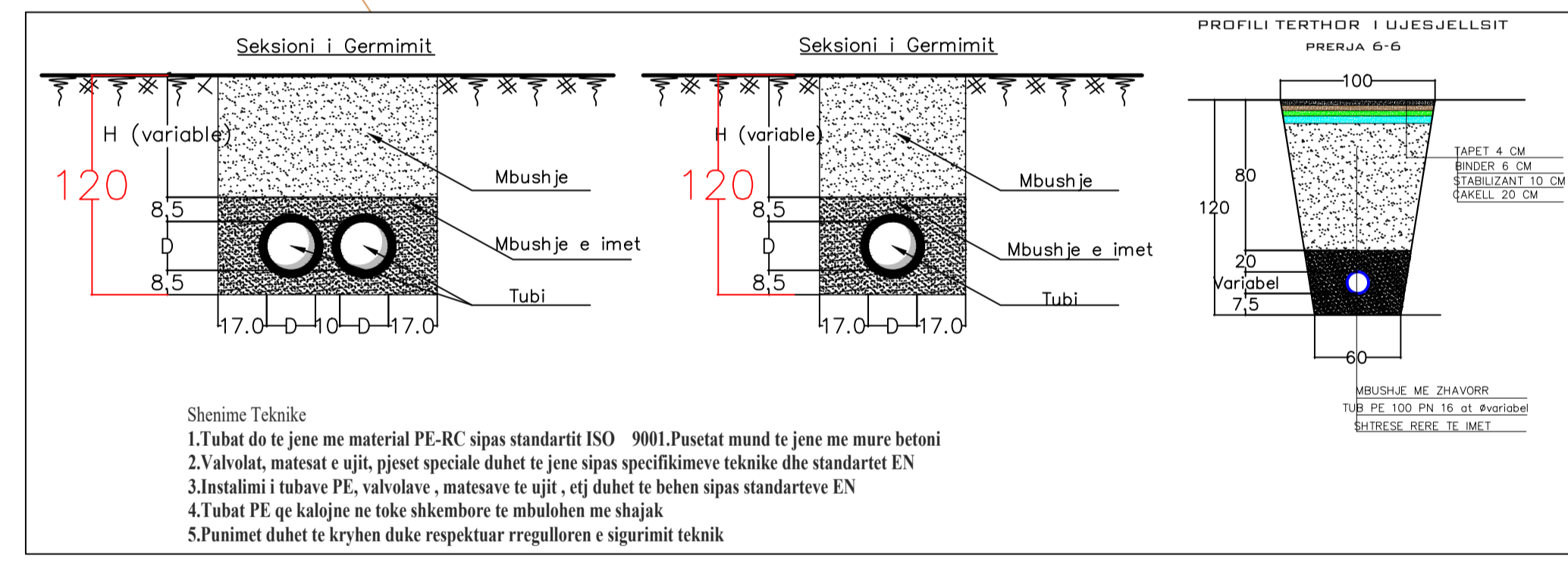
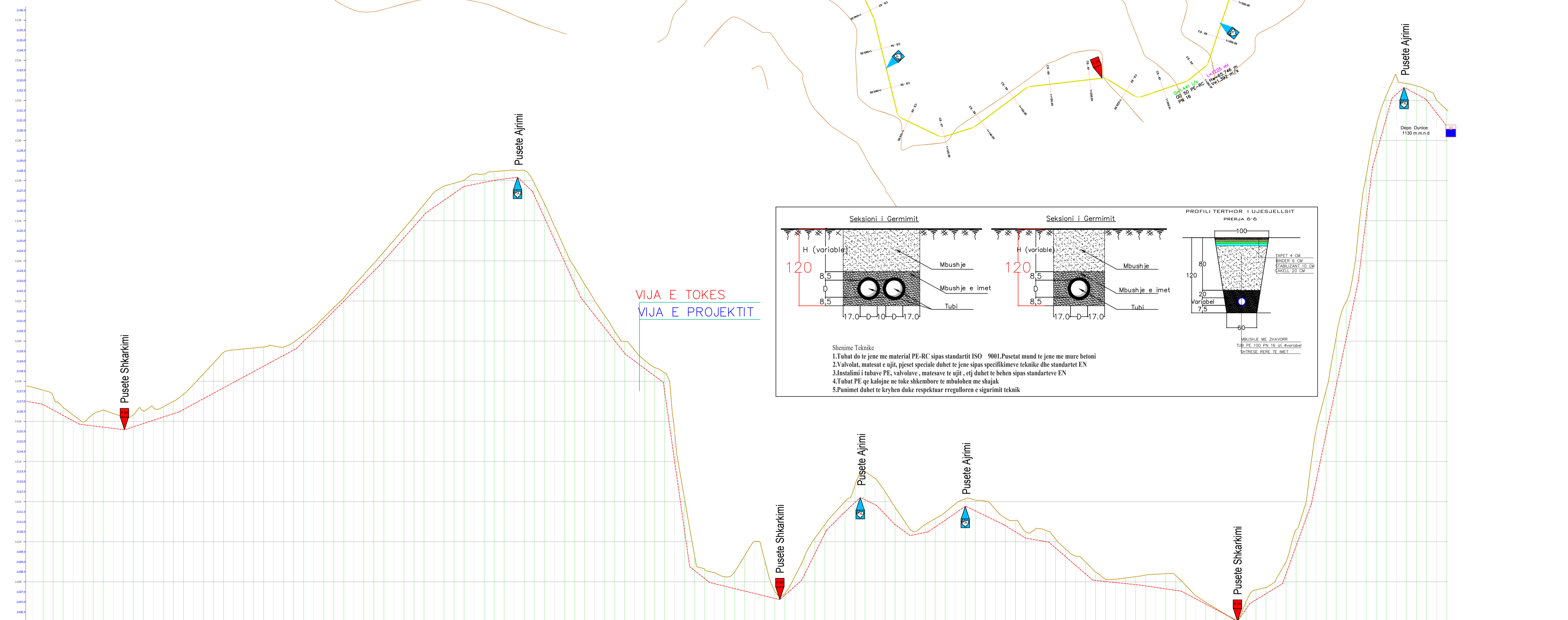
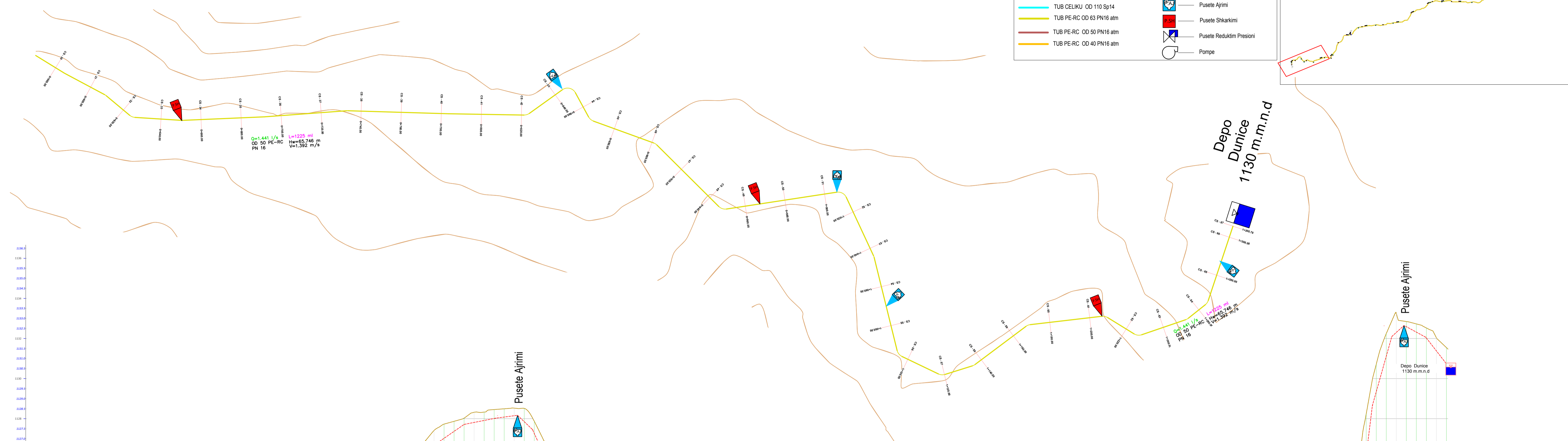
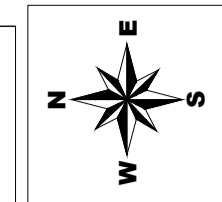

KUOTA TOKES	
KUOTA PROJEKTTIT	
DIST PROGRESIVE	
DIST PËSORE	
NR I PËRYES	
KILOMETRAZH	
ELEMENTET HIDRAULIK	

**Investitor :**  
**BASHKIA POGRADEC**  
 Adresa:  
 Bulevardi "Reshit Collaku"  
 Pogradec - Shqipëri  
 Web: www.bashkiapogradec.al  
 Email: bashkiapogradec@gmail.com



**Objekti: "NDËRTIM UJËSJELLËSI RAJONAL TREBINJË - BURIMET E KOZICËS"**

Numri i projektit: **AL\_PG\_N\_U\_R\_T-B\_K**  
 Vendodhja e projektit: **POGRADEC**

Grupi teknik i projektimit:  
**"ERALD-G" shpk Nr. Lic. N- 5304/11**

Ruga "KONGRESI I LUSHNYES"  
 Tiranë  
 eraldgshpk@yahoo.com  
 Tel +355 4 357 970  
 Cel +355 682090392

Administrator:  
**Gëzim ISLAMI**

Inxhinier Konstruktor:  
**Gëzim ISLAMI** Lic. K-1196/6

Inxhinier Hidroteknik:  
**Ersida VERCANI** Lic. K-1807/2

Arkitekt:  
**Elton CARCANI** Lic. A-0733/3

Inxhinier Elektrik:  
**Hajdar KURTI** Lic. E-0180/5

Inxhinier Topograf:  
**Kujtim CANAMETI** Lic. T-1058/3

Inxhinier Mekanik:  
**Arben MUHA** Lic. M-0308/3

Inxhinier Gjeolog:  
**Leonard KAZANXHIU** Lic. GJ-0556/3

Inxhinier Infrastruktura:  
**Gëzim ISLAMI** Lic. K-1196/6

Inxhinier Teknolog:  
**Ylber CANI**  
 Inxhinier Mjedisit:  
**Nensi MEHMETI**

Emërtimi i fletës:  
**PROFILI GJATESOR**  
 Depo Guri i Bardhe - Dunicë

Faza e projektit:  
**Projekt Zbatimi**

Formati: **A1**  
 Shkalla: **SHV 1:100, SHH 1:1000**

Nr i fletes: **P.GJ.26**

Data:  
**2020**