



Bashkia Malesia e Madhe

Faza Projekt-Zbatimi
VIZATIMET

***NDERTIMI I UJESJELLESIT TE BAJZES DHE FSHATRAVE PERRETH LOTI II,
BASHKIA MALESI E MADHE***

Prerje Tip+Detaje



PRERJA TERTHORE TIP, PER NJE TUBACION DN 200 NE RRUGET ME ASFALT

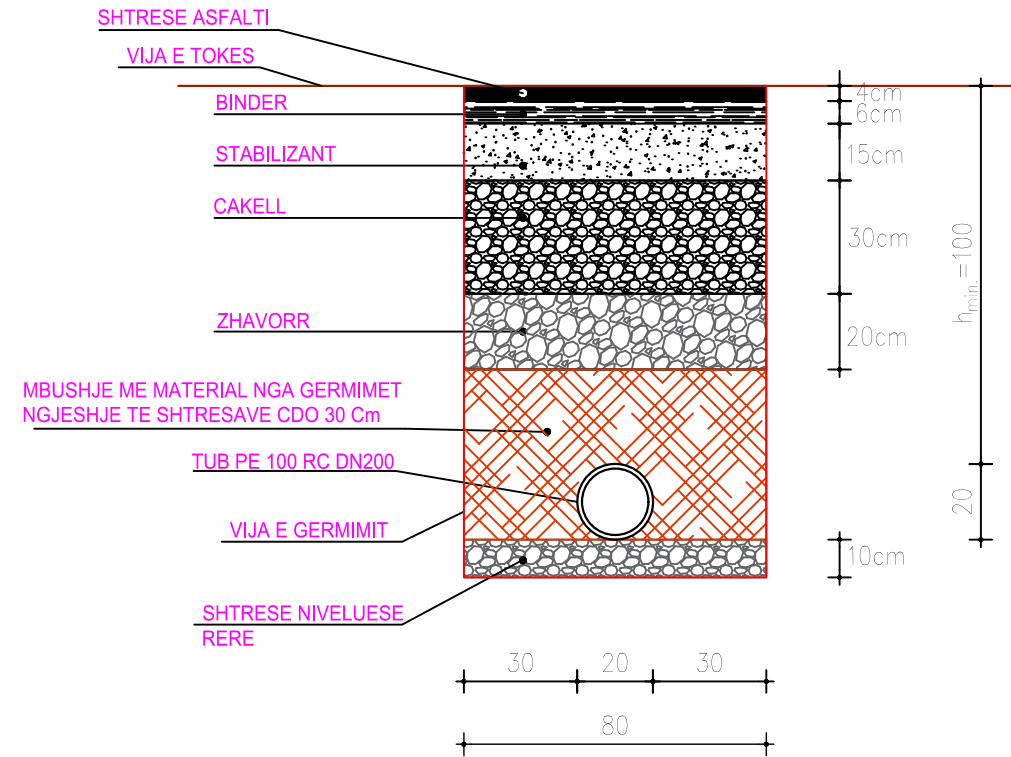

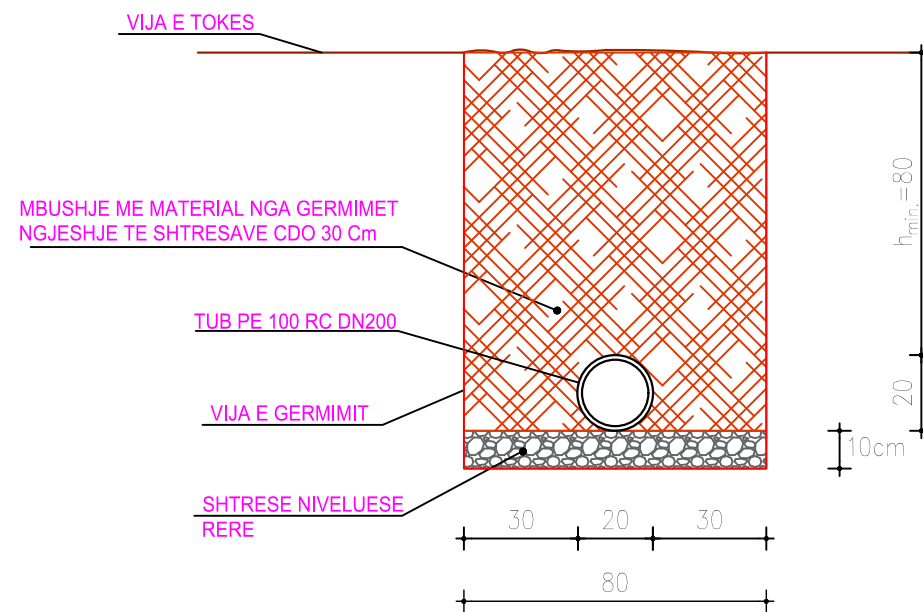

PRERJA TERTHORE TIP, PER NJE TUBACION DN 200 NE RRUGET PA ASFALT DHE ARE



SHENIM:

*Shtresat e rruges qe do te demtohen gjate kalimit te tubit do te ribehen me po te njejten trashesi sipas faktit.
Rendesit te vecante ka ngjeshja e nenshtresave per shmangien e cedimeve gjate kalimit te automjeteve.*

INVESTITORI:	 Bashkia Malesi e Madhe
PROJEKTUES:	 InfraKonsult sh.p.k.
Faza:Projekt-Zbatim	
OBJEKTI: "NDERTIM I UJESJELLESIT TE BAJZES DHE FSHATRAVE PERRETH" LOTI II	
Prerje Terthore Tip Tubacion DN 200	
DREJTOR PROJEKTI:	Ing. Sulejman Shemsiu
PROJEKTUES:	Ing. Redi STRUGA Ing. Olsi BARKO Ing. Sokol METOJA Ing. Fatmir BEXHDILI Ing. Kejvin PASHOLLARI Ing. Orgest MERTIKA Ing. Renato LLOZHI
SHKALLA: 1:20	Data: Gusht, 2024 Vizatimi Nr: 11 /02

PRERJA TERTHORE TIP, PER NJE TUBACION DN 140 NE RRUGET ME ASFALT

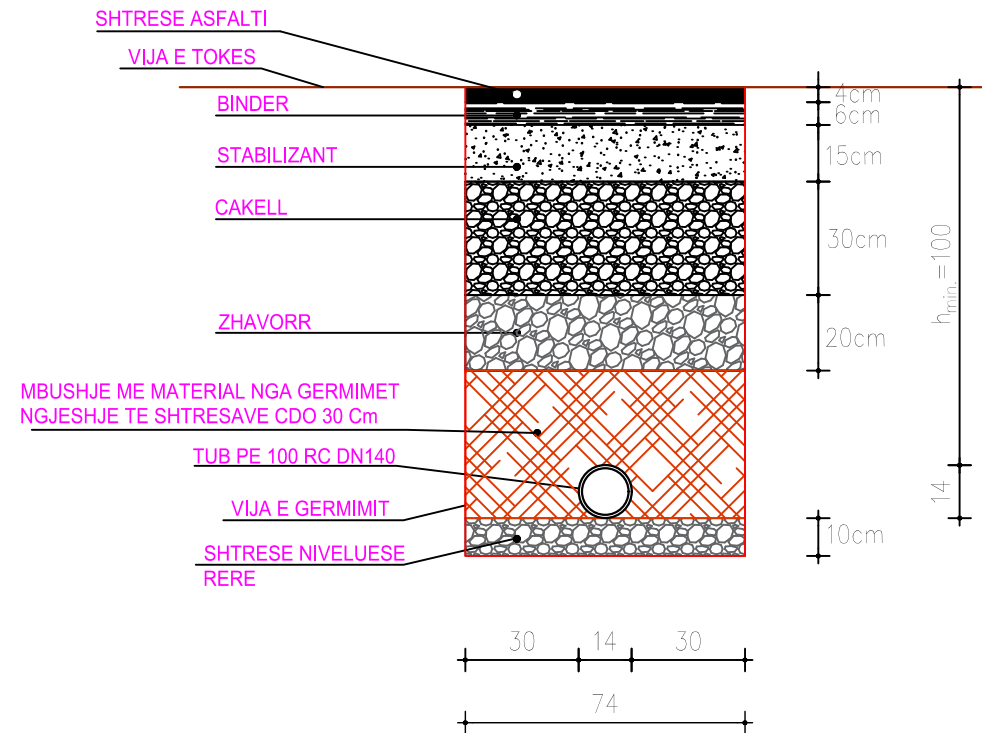

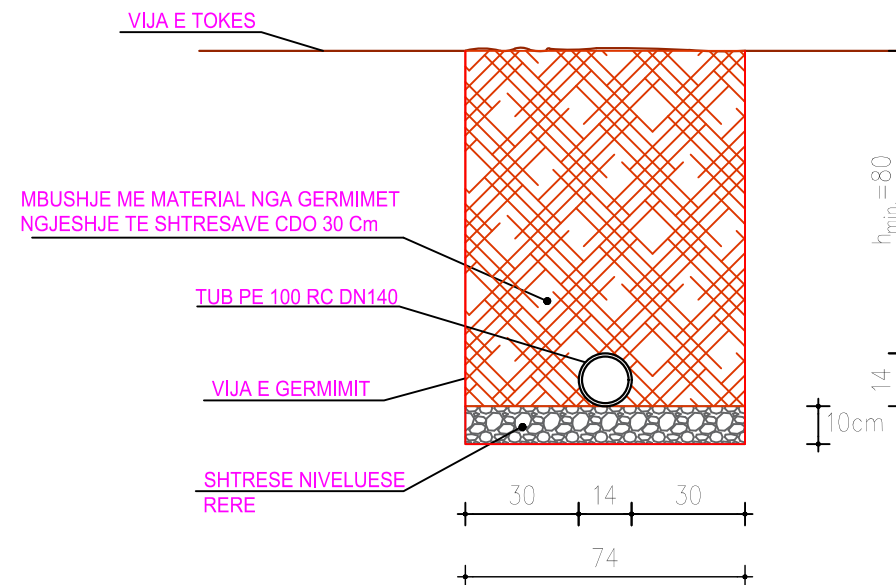

PRERJA TERTHORE TIP, PER NJE TUBACION DN 140 NE RRUGET PA ASFALT DHE ARE



SHENIM:

Shtresat e rruges qe do te demtohen gjate kalimit te tubit do te ribehen me po te njejten trashesi sipas faktit.
Rendesiti te vecante ka ngjeshja e nenshtresave per shmangien e cedimeve gjate kalimit te automjeteve.

INVESTITORI:	 Bashkia Malesi e Madhe
PROJEKTUES:	 InfraKonsult sh.p.k.
Faza:Projekt-Zbatim	
OBJEKTI: "NDERTIM I UJESJELLESIT TE BAJZES DHE FSHATRAVE PERRETH" LOTI II	
Prerje Terthore Tip Tubacion DN 140	
DREJTOR PROJEKTI:	Ing. Sulejman Shemsiu
PROJEKTUES:	Ing. Redi STRUGA Ing. Olsi BARKO Ing. Sokol METOJA Ing. Fatmir BEXHDILI Ing. Kejvin PASHOLLARI Ing. Orgest MERTIKA Ing. Renato LLOZHI
SHKALLA: 1:20	Data: Gusht, 2024
Vizatimi Nr: 11 /04	

PRERJA TERTHORE TIP, PER NJE TUBACION DN 110 NE RRUGET ME ASFALT

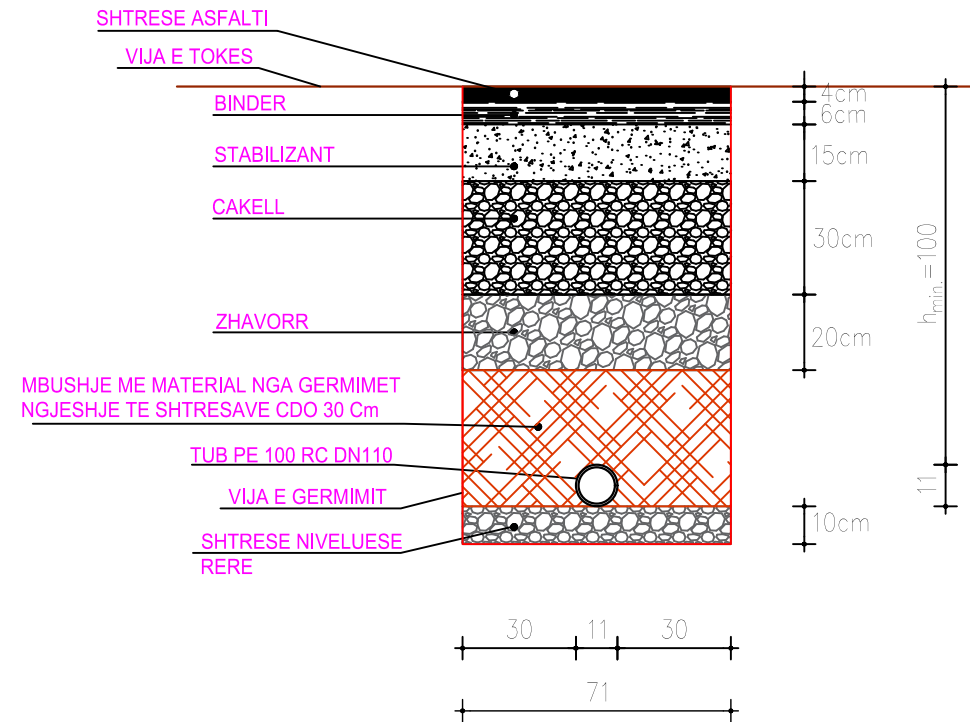

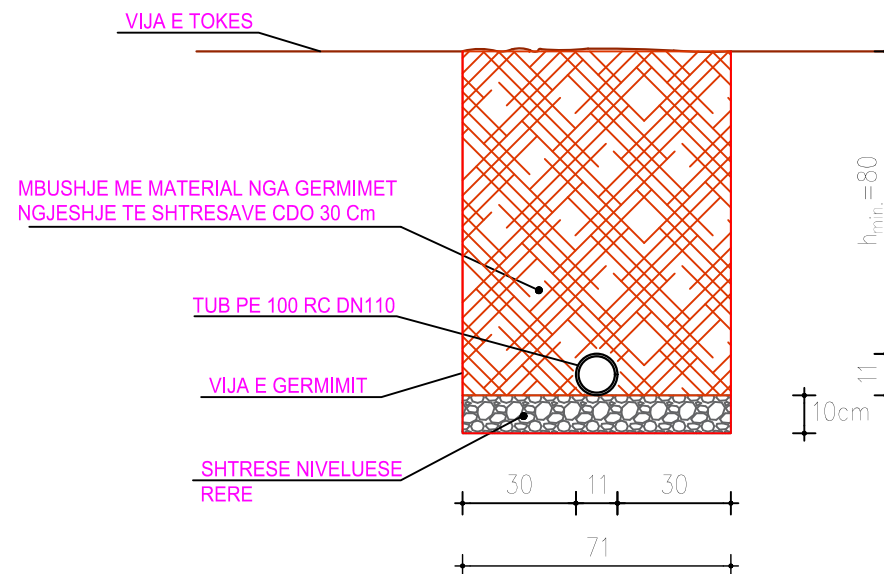

PRERJA TERTHORE TIP, PER NJE TUBACION DN 110 NE RRUGET PA ASFALT DHE ARE



SHENIM:

Shtresat e rruges qe do te demtohen gjate kalimit te tubit do te ribehen me po te njejten trashesi sipas faktit.
Rendesiti te vecante ka ngjeshja e nenshtresave per shmangien e cedimeve gjate kalimit te automjeteve.

INVESTITORI:	 Bashkia Malesi e Madhe
PROJEKTUES:	 InfraKonsult sh.p.k.
Faza:Projekt-Zbatim	
OBJEKTI: "NDERTIM I UJESJELLESIT TE BAJZES DHE FSHATRAVE PERRETH" LOTI II	
Prerje Terthore Tip Tubacion DN 110	
DREJTOR PROJEKTI:	Ing. Sulejman Shemsiu
PROJEKTUES:	Ing. Redi STRUGA Ing. Olsi BARKO Ing. Sokol METOJA Ing. Fatmir BEXHDILI Ing. Kejvin PASHOLLARI Ing. Orgest MERTIKA Ing. Renato LLOZHI
SHKALLA: 1:20	Data: Gusht, 2024
Vizatimi Nr: 11 /06	

PRERJA TERTHORE TIP, PER NJE TUBACION DN 90 NE RRUGET ME ASFALT

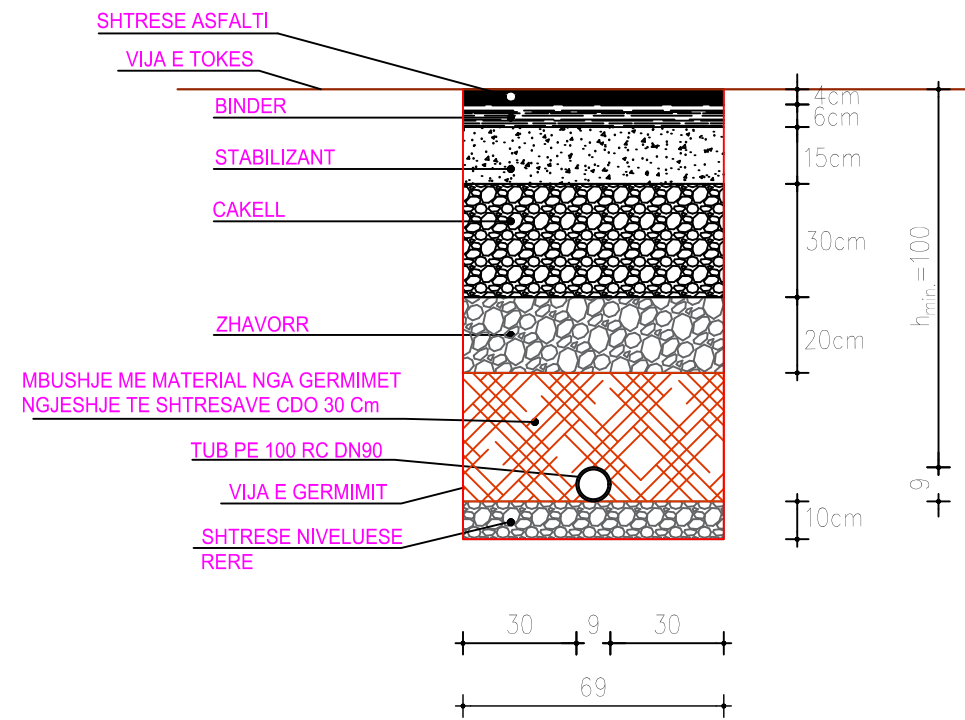

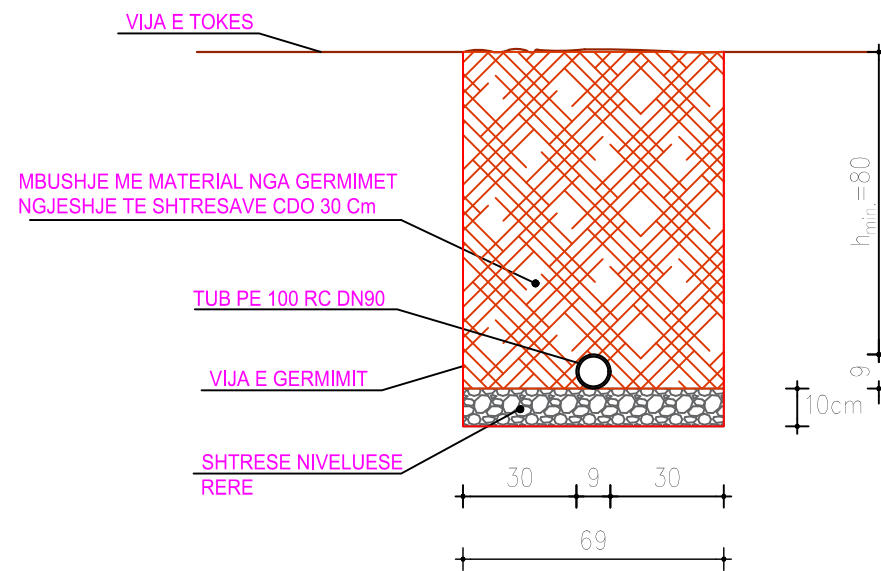

PRERJA TERTHORE TIP, PER NJE TUBACION DN 90 NE RRUGET PA ASFALT DHE ARE



SHENIM:

Shtresat e rruges qe do te demtohen gjate kalimit te tubit do te ribehen me po te njejten trashesi sipas faktit.
Rendesiti te vecante ka ngjeshja e nenshtresave per shmangien e cedimeve gjate kalimit te automjeteve.

INVESTITORI:	 Bashkia Malesi e Madhe
PROJEKTUES:	 InfraKonsult sh.p.k.
Faza:Projekt-Zbatim	
OBJEKTI: "NDERTIM I UJESJELLESIT TE BAJZES DHE FSHATRAVE PERRETH" LOTI II	
Prerje Terthore Tip Tubacion DN 90	
DREJTOR PROJEKTI:	Ing. Sulejman Shemsiu
PROJEKTUES:	Ing. Redi STRUGA Ing. Olsi BARKO Ing. Sokol METOJA Ing. Fatmir BEXHDILI Ing. Kejvin PASHOLLARI Ing. Orgest MERTIKA Ing. Renato LLOZHI
SHKALLA: 1:20	Data: Gusht, 2024
Vizatimi Nr: 11 / 07	

PRERJA TERTHORE TIP, PER NJE TUBACION DN 75 NE RRUGET ME ASFALT

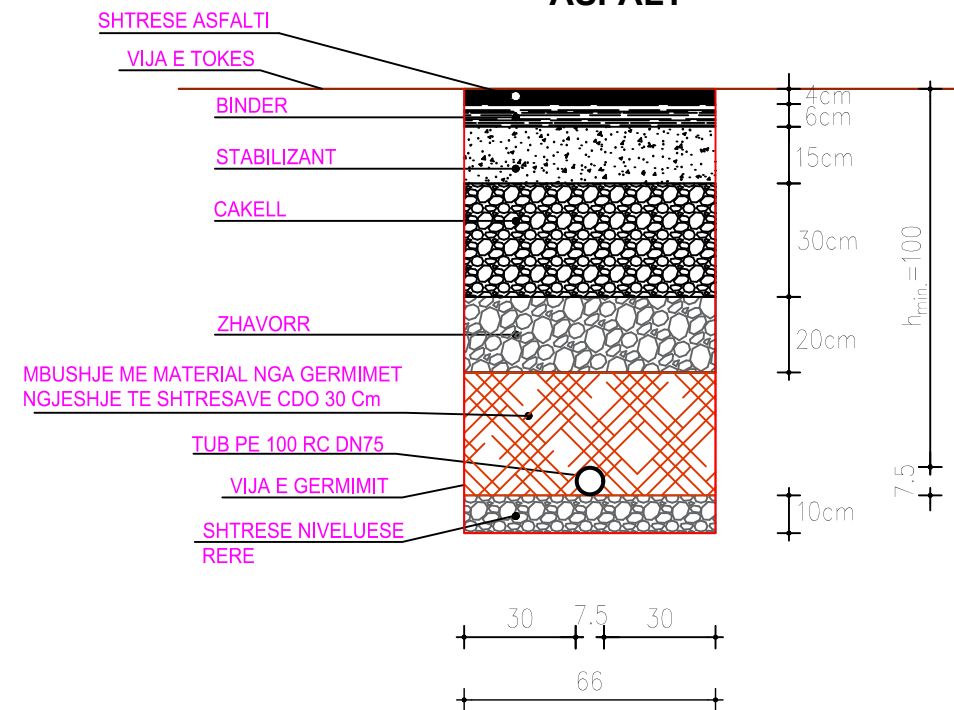

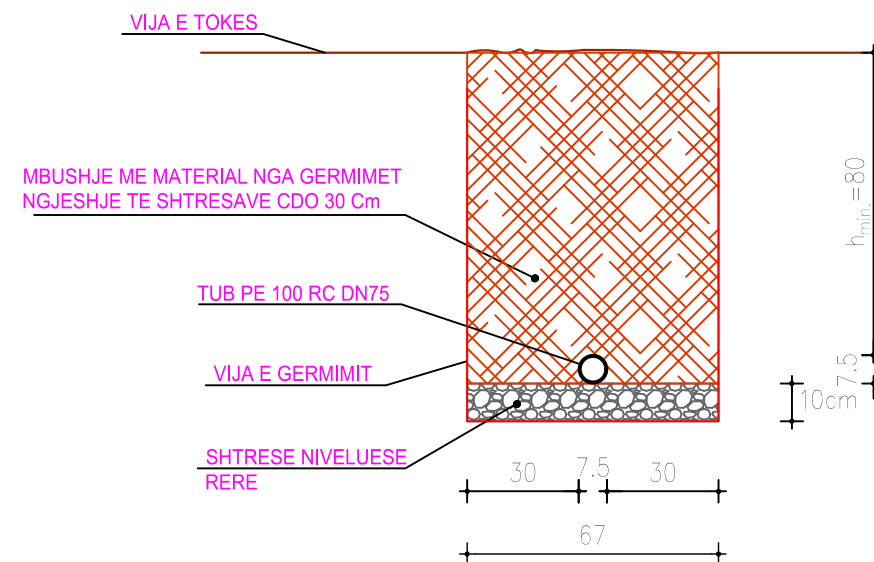

PRERJA TERTHORE TIP, PER NJE TUBACION DN 75 NE RRUGET PA ASFALT DHE ARE



SHENIM:

Shtresat e rruges qe do te demtohen gjate kalimit te tubit do te ribehen me po te njejten trashesi sipas faktit.
Rendesit te vecante ka ngjeshja e nenshtresave per shmangien e cedimeve gjate kalimit te automjeteve.

INVESTITORI:	 Bashkia Malesi e Madhe
PROJEKTUES:	 InfraKonsult sh.p.k.
Faza:Projekt-Zbatim	
OBJEKTI: "NDERTIM I UJESJELLESIT TE BAJZES DHE FSHATRAVE PERRETH" LOTI II	
Prerje Terthore Tip Tubacion DN 75	
DREJTOR PROJEKTI:	Ing. Sulejman Shemsiu
PROJEKTUES:	Ing. Redi STRUGA Ing. Olsi BARKO Ing. Sokol METOJA Ing. Fatmir BEXHDILI Ing. Kejvin PASHOLLARI Ing. Orgest MERTIKA Ing. Renato LLOZHI
SHKALLA: 1:20	Data: Gusht, 2024
Vizatimi Nr: 11 /08	

PRERJA TERTHORE TIP, PER NJE TUBACION DN 50 NE RRUGET ME ASFALT

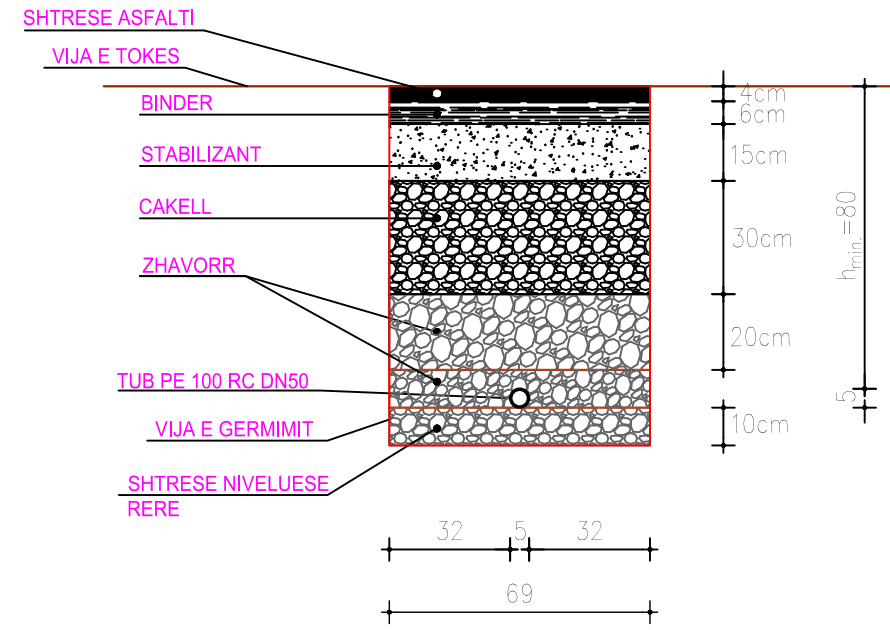

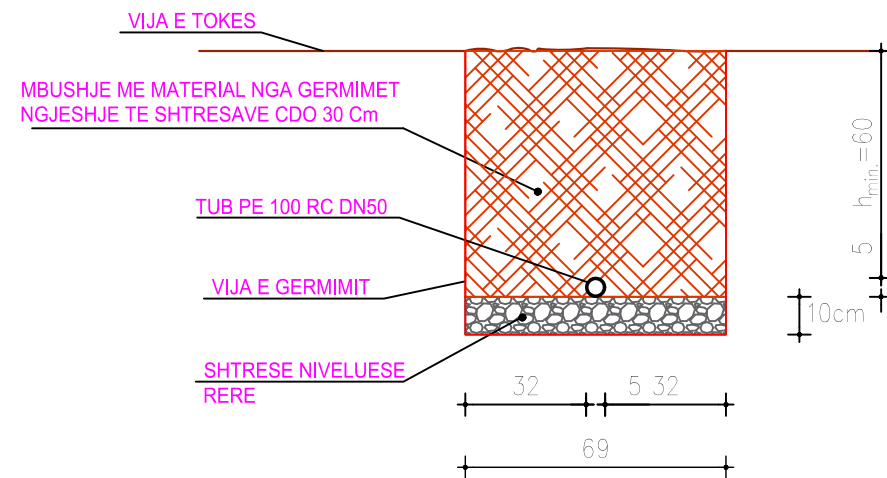

PRERJA TERTHORE TIP, PER NJE TUBACION DN 50 NE RRUGET PA ASFALT DHE ARE



SHENIM:

Shtresat e rruges qe do te demtohen gjate kalimit te tubit do te ribehen me po te njejten trashesi sipas faktit.
Rendesiti te vecante ka ngjeshja e nenshtresave per shmangien e cedimeve gjate kalimit te automjeteve.

INVESTITORI:	 Bashkia Malesi e Madhe
PROJEKTUES:	 InfraKonsult sh.p.k.
Faza:Projekt-Zbatim	
OBJEKTI: "NDERTIM I UJESJELLESIT TE BAJZES DHE FSHATRAVE PERRETH" LOTI II	
Prerje Terthore Tip Tubacion DN 50	
DREJTOR PROJEKTI:	Ing. Sulejman Shemsiu
PROJEKTUES:	Ing. Redi STRUGA Ing. Olsi BARKO Ing. Sokol METOJA Ing. Fatmir BEXHDILI Ing. Kejvin PASHOLLARI Ing. Orgest MERTIKA Ing. Renato LLOZHI
SHKALLA: 1:20	Data: Gusht, 2024
Vizatimi Nr: 11 /09	

PRERJA TERTHORE TIP, PER NJE TUBACION DN 20 NE RRUGET ME ASFALT

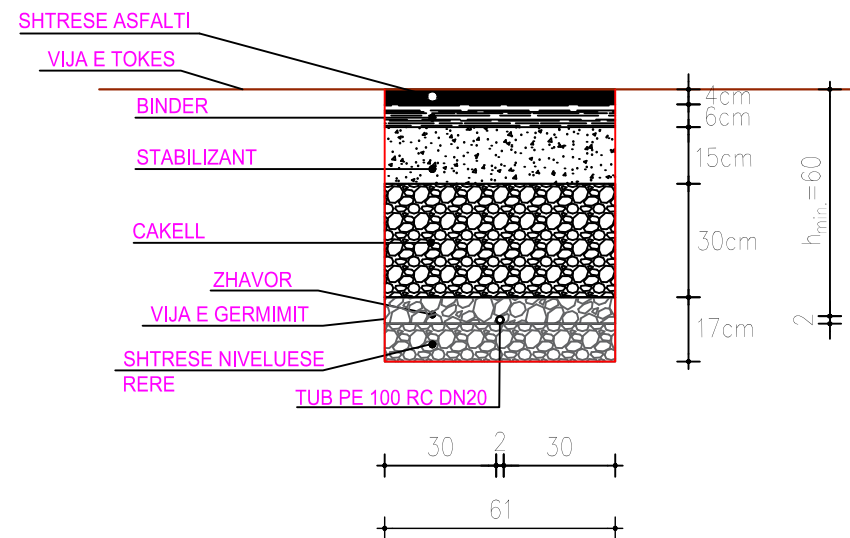

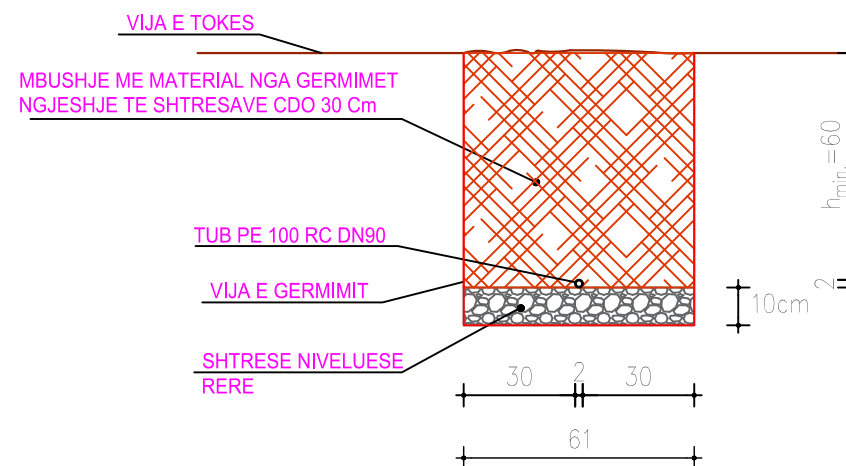

PRERJA TERTHORE TIP, PER NJE TUBACION DN 20 NE RRUGET PA ASFALT DHE ARE



SHENIM:



Shtresat e rruges qe do te demtohen gjate kalimit te tubit do te ribehen me po te njejten trashesi sipas faktit.

Rendesiti te vecante ka ngjeshja e nenshtresave per shmangien e cedimeve gjate kalimit te automjeteve.

INVESTITORI:	 Bashkia Malesi e Madhe
PROJEKTUES:	 InfraKonsult sh.p.k.
Faza:Projekt-Zbatim	
OBJEKTI: "NDERTIM I UJESJELLESIT TE BAJZES DHE FSHATRAVE PERRETH" LOTI II	
Prerje Terthore Tip Tubacion DN 20	
DREJTOR PROJEKTI:	Ing. Sulejman Shemsiu
PROJEKTUES:	Ing. Redi STRUGA Ing. Olsi BARKO Ing. Sokol METOJA Ing. Fatmir BEXHDILI Ing. Kejvin PASHOLLARI Ing. Orgest MERTIKA Ing. Renato LLOZHI
SHKALLA: 1:20	Data: Gusht, 2024
Vizatimi Nr: 11 / 10	

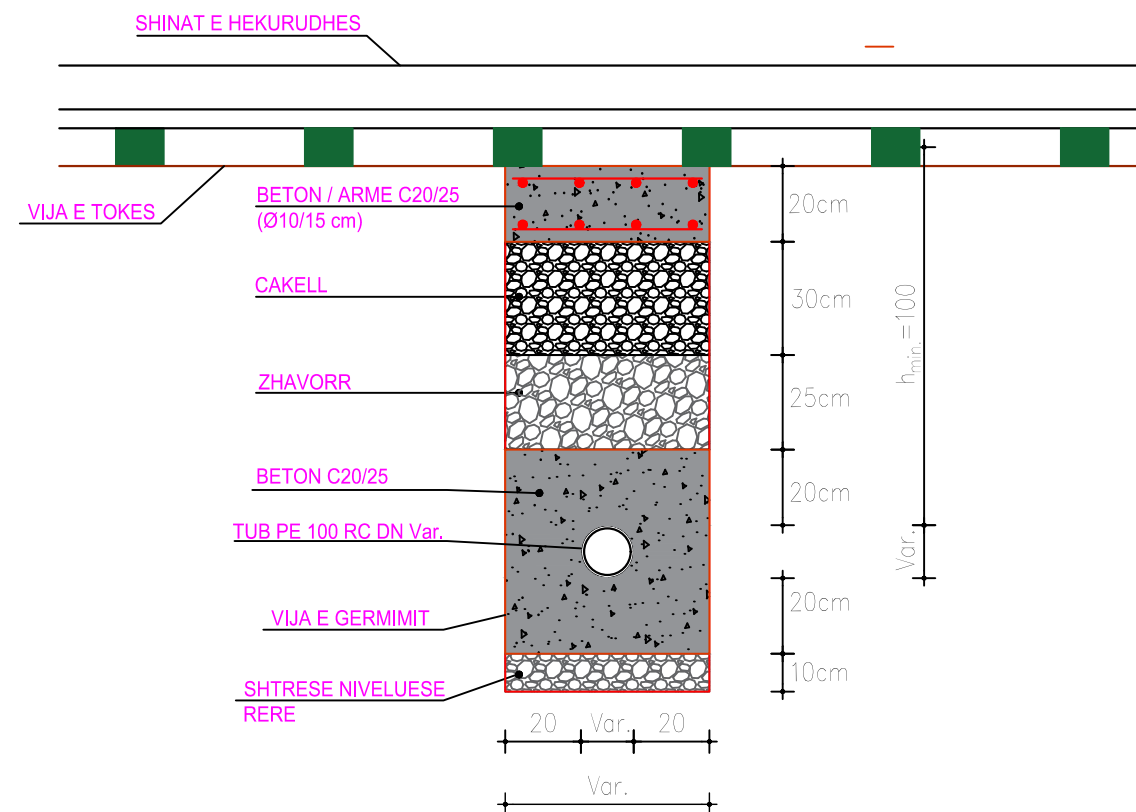

PRERJA TERTHORE TIP E VENDOSJES SE TUBACIONIT NE INTERSEKTIM HEKURUDHE

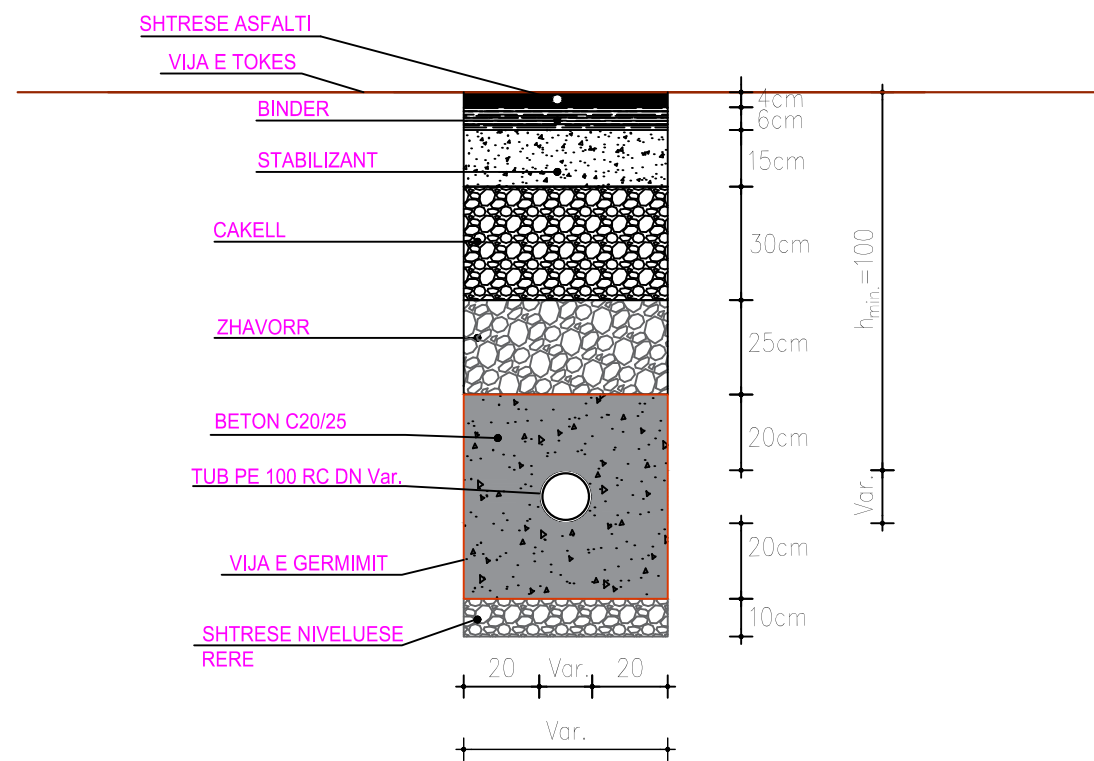

INVESTITORI:		Bashkia Malesi e Madhe
PROJEKTUES:		InfraKonsult sh.p.k.
Faza:Projekt-Zbatim		
OBJEKTI: "NDERTIM I UJESJELLESIT TE BAJZES DHE FSHATRAVE PERRETH" LOTI II		
Prerje Terthore Tip e Tubacionit ne Intersektim Hekurudhe		
DREJTOR PROJEKTI: Ing. Sulejman Shemsiu		
PROJEKTUES:	Ing. Redi STRUGA Ing. Olsi BARKO Ing. Sokol METOJA Ing. Fatmir BEXHDILI Ing. Kejvin PASHOLLARI Ing. Orgest MERTIKA Ing. Renato LLOZHI	
SHKALLA: 1:20	Data: Gusht, 2024	
	Vizatimi Nr: 11 / 17	

PRERJA TERTHORE TIP E VENDOSJES SE TUBACIONIT
NE INTERSEKTIM RRUGE AUTOMOBILISTIKE



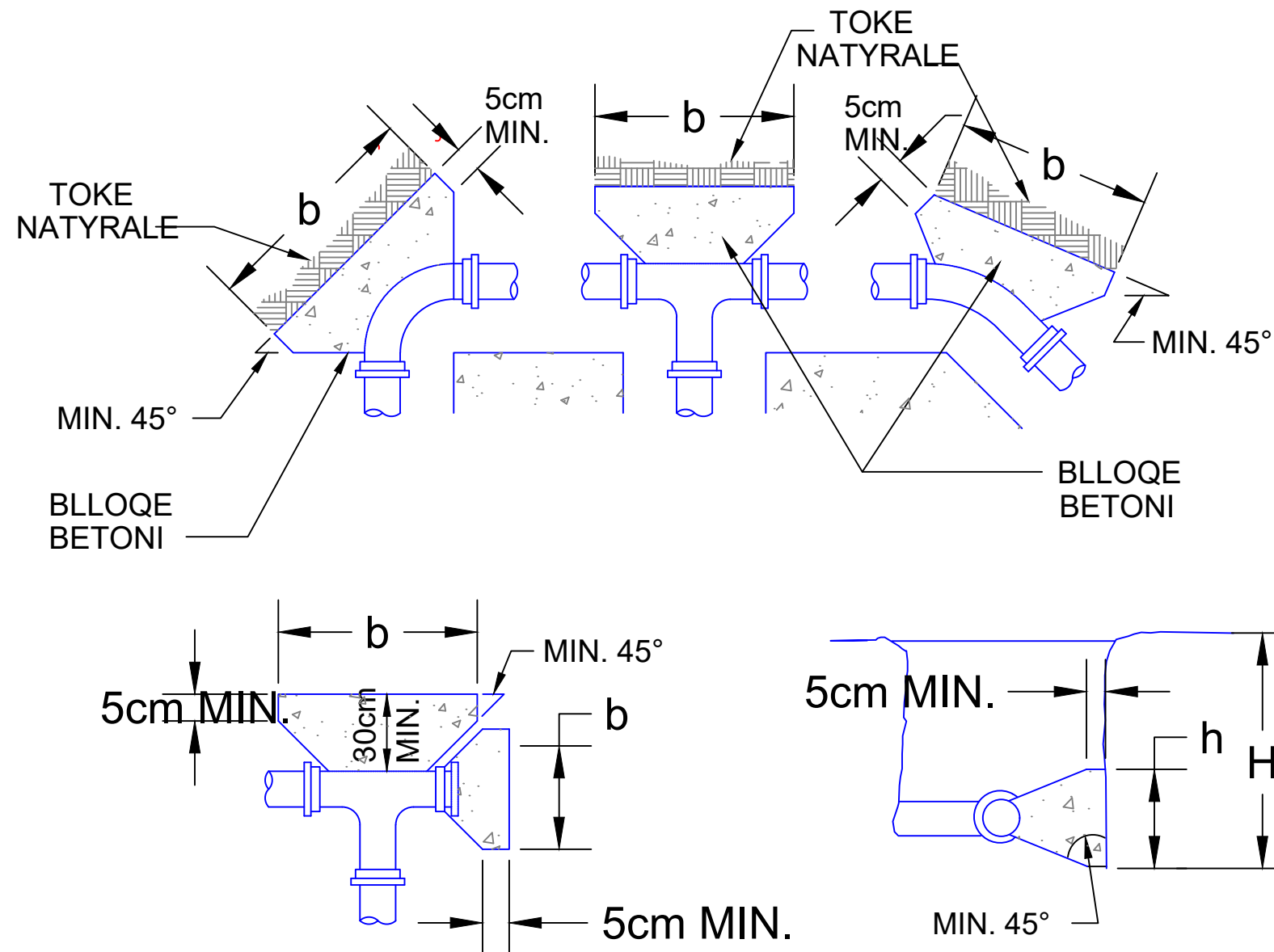

INVESTITORI:	 Bashkia Malesi e Madhe
PROJEKTUES:	 InfraKonsult sh.p.k.
Faza:Projekt-Zbatim	
OBJEKTI: "NDERTIM I UJESJELLESIT TE BAJZES DHE FSHATRAVE PERRETH" LOTI II	
Prerje Terthore Tip e Tubacionit ne Intersektim Rruge	
DREJTOR PROJEKTI: Ing. Sulejman Shemsiu	
PROJEKTUES:	Ing. Redi STRUGA Ing. Olsi BARKO Ing. Sokol METOJA Ing. Fatmir BEXHDILI Ing. Kejvin PASHOLLARI Ing. Orgest MERTIKA Ing. Renato LLOZHI
SHKALLA: 1:20	Data: Gusht, 2024
Vizatimi Nr: 11 / 18	

TIP I BLOKUT TE ANKORIMIT



SHENIM:

1. VENDOS 4 ml. POLIETELIN MIDIS BETONIT DHE RAKORDERIVE (BETONI NUK DUHET TE LIDHET DIREKT ME RAKORDERITE.)
2. TRASHESIA MINIMALE E BETONIT DUHET TE JETE 5 CM.
3. DIMENSIONI MINIMAL HORIZONTAL (b) I MBUSHJES DUHET TE JETE 1.0 DHE 2.0 SA DIMENSIONI VERTIKAL (h).
($h \leq b \leq 2h$)
4. DIMENSIONI VERTIKAL (h) I MBUSHJES DUHE TE JETE I BARABARTE ME GJYSEM E h TOTALE (H) NGA FUNDI.
5. AKSI I BLOKUT TE BETONIT DUHET TE JETE NE QENDER TE RAKORDERISE QENDRA E BLOKUT TE BETONIT DUHET TE JETE I BARBARTE ME QENDREN E RAKORDERISE
6. KENDI MINIMUM I LEJUAR DUHET TE JETE 45 GRADE

INVESTITORI:	 Bashkia Malesi e Madhe
PROJEKTUES:	 InfraKonsult sh.p.k.
Faza:Projekt-Zbatim	
OBJEKTI: "NDERTIM I UJESJELLESIT TE BAJZES DHE FSHATRAVE PERRETH" LOTI II	
Tip i Bllokut te Ankorimit	
DREJTOR PROJEKTI:	Ing. Sulejman Shemsiu
PROJEKTUES:	Ing. Redi STRUGA Ing. Olsi BARKO Ing. Sokol METOJA Ing. Fatmir BEXHDILI Ing. Kejvin PASHOLLARI Ing. Orgest MERTIKA Ing. Renato LLOZHI
SHKALLA: 1:20	Data: Gusht, 2024
Vizatimi Nr: 11 / 19	