

TABELA E SPECIFIKIMIT TE ARMATURES NE KUOTEN +11.27 m

TABELA E SPECIFIKIMIT TE ARMATURES					
Nr	FORMA DHE PERMASAT [cm]	Ø [mm]	l [m]	n [copel]	l(totale) [m]
1		12	3.00	52	156.00
2		12	9.00	52	468.00
3		12	9.00	52	468.00
4		12	5.00	52	260.00
5		12	9.00	52	468.00
6		12	9.00	52	468.00
7		8	4.50	21	94.50
8		12	5.00	52	260.00
9		10	8.00	52	416.00
10		8	5.00	27	135.00
11		8	5.00	27	135.00
12		8	4.50	27	121.50
13		8	5.00	21	105.00
14		8	5.00	21	105.00
15		12	8.00	41	328.00
16		12	9.00	41	369.00
17		12	9.00	41	369.00
18		12	5.00	41	205.00
19		12	5.00	41	205.00
20		12	5.00	41	205.00
21		12	3.00	41	123.00

22		12	9.00	41	369.00
23		12	9.00	41	369.00
24		12	9.00	53	477.00
25		12	9.00	53	477.00
26		12	9.80	53	519.40
27		12	5.00	53	265.00
28		12	5.00	53	265.00
29		12	3.00	53	159.00
30		8	4.50	17	76.50
31		8	5.00	17	85.00
32		8	5.00	16	80.00
33		12	8.00	33	264.00
34		12	9.00	33	297.00
35		12	9.00	33	297.00
36		12	5.00	33	165.00
37		12	5.00	33	165.00
38		12	5.00	33	165.00
39		12	3.00	32	96.00
40		12	9.00	32	288.00
41		12	9.00	10	90.00
42		12	9.00	55	495.00
43		12	9.00	55	495.00

44		12	9.80	55	539.00
45		12	5.00	55	275.00
46		12	12.00	55	660.00
47		8	7.00	16	112.00
48		8	12.00	16	192.00
49		8	9.80	18	176.40
50		12	12.00	19	228.00
51		8	12.00	18	216.00
52		8	12.00	16	192.00
53		8	7.00	28	196.00
54		12	11.00	28	308.00
55		10	7.20	28	201.60
56		10	12.00	28	336.00
57		8	7.00	25	175.00
58		12	11.00	25	275.00
59		10	7.20	25	180.00
60		10	12.00	25	300.00
61		10	7.00	31	217.00
62		12	11.00	34	374.00
63		10	7.20	41	295.20
64		10	12.00	34	408.00

65		8	5.20	15	78.00
66		8	3.00	29	87.00
67		8	3.00	29	87.00
68		8	9.00	29	261.00
69		8	5.20	16	83.20
70		8	3.00	30	90.00
71		8	3.00	30	90.00
72		8	9.00	30	270.00
73		8	5.20	20	104.00
74		8	3.00	39	117.00
75		8	3.00	39	117.00
76		8	9.00	39	351.00
77		10	7.00	29	203.00
78		8	11.00	17	187.00
79		8	9.00	17	153.00
80		8	12.00	30	360.00
81		8	5.20	20	104.00
82		8	4.50	39	175.50
83		8	3.00	39	117.00
84		8	9.00	39	351.00

TABELA E SPECIFIKIMIT TE ARMATURES NE KUOTEN +1.27 m

85	1200	8	12.00	40	480.00	105	180	8	2.40	44	105.60	129	570	12	6.00	24	144.00	150	750	12	7.50	62	465.00
86	640	8	7.00	28	196.00	106	1140	8	12.00	43	516.00	130	235	12	3.00	64	192.00	151	715	12	7.50	47	352.50
87	870	8	9.00	22	198.00	107	900	8	9.00	43	387.00	131	750	12	7.50	64	480.00	152	800	12	8.00	61	488.00
88	1140	8	12.00	17	204.00	108	350	8	3.50	21	73.50	132	350	8	3.50	33	115.50	153	465	12	5.00	61	305.00
89	700	8	7.00	17	119.00	109	500	8	5.00	8	40.00	133	570	12	6.00	62	372.00	154	750	12	7.50	61	457.50
90	1100	8	11.00	17	187.00	110	500	8	5.00	21	105.00	134	300	8	3.00	33	99.00	155	240	12	3.00	61	183.00
91	470	8	5.00	40	200.00	111	630	8	6.30	31	195.30	135	1050	12	10.50	64	672.00	156	320	8	3.20	22	70.40
92	900	8	9.00	40	360.00	112	300	8	3.00	23	69.00	136	735	12	8.00	64	512.00	157	160	8	2.20	42	92.40
93	470	8	5.00	15	75.00	113	630	8	6.30	31	195.30	137	1050	12	10.50	64	672.00	158	600	8	6.00	42	252.00
94	670	8	7.00	13	91.00	114	320	10	3.50	67	234.50	138	735	12	8.00	64	512.00	159	180	8	2.40	42	100.80
95	850	8	8.50	15	127.50	115	600	10	6.00	66	396.00	139	570	12	6.00	64	384.00	160	630	8	6.30	42	264.60
96	900	8	9.00	43	387.00	116	1170	10	12.00	68	816.00	140	350	8	3.50	33	115.50	161	560	8	6.50	21	136.50
97	900	8	9.00	44	396.00	117	600	10	6.00	67	402.00	141	750	12	7.50	64	480.00	162	570	8	5.70	20	114.00
98	570	8	6.00	44	264.00	118	500	8	5.00	66	330.00	142	235	12	3.00	64	192.00	163	1200	8	12.00	47	564.00
99	870	8	9.00	44	396.00	119	450	8	4.50	67	301.50	143	1050	12	10.50	24	252.00	164	1165	12	12.00	47	564.00
100	1140	8	12.00	43	516.00	120	1050	12	10.50	66	693.00	144	320	8	3.20	34	108.80	165	865	8	9.00	29	261.00
101	900	8	9.00	44	396.00	121	1170	12	12.00	66	792.00	145	320	8	3.20	33	105.60	166	1200	12	12.00	47	564.00
102	680	8	6.80	44	299.20	122	750	12	7.50	66	495.00	146	535	12	6.00	62	372.00	167	650	8	6.50	29	188.50
103	770	8	8.00	44	352.00	123	735	12	8.00	24	192.00	147	1050	12	10.50	62	651.00	168	175	8	2.40	29	69.60
104	1140	8	12.00	44	528.00	124	1050	12	10.50	29	304.50	148	465	12	5.00	62	310.00	169	715	12	7.50	31	232.50
105	180	8	2.40	44	105.60	125	1050	12	10.50	29	304.50	149	240	12	3.00	62	186.00	170	715	12	7.50	31	232.50
106	1140	8	12.00	43	516.00	126	750	8	7.50	24	180.00	150	350	8	3.50	13	45.50	171	715	12	7.50	31	232.50
107	900	8	9.00	43	387.00	127	350	8	3.50	13	45.50	151	235	8	3.00	24	72.00	172	235	8	3.00	24	72.00
108	350	8	3.50	21	73.50	128	235	8	3.00	24	72.00	152	570	12	6.00	62	372.00	173	235	8	3.00	24	72.00
109	500	8	5.00	8	40.00	129	570	12	6.00	62	372.00	153	735	12	8.00	64	512.00	174	600	8	6.00	42	252.00
110	500	8	5.00	21	105.00	130	320	10	3.50	67	234.50	154	1050	12	10.50	64	672.00	175	600	8	6.00	42	252.00
111	630	8	6.30	31	195.30	131	600	10	6.00	66	396.00	155	735	12	8.00	64	512.00	176	600	8	6.00	42	252.00
112	300	8	3.00	23	69.00	132	300	8	3.00	23	69.00	156	320	8	3.20	22	70.40	177	320	8	3.20	22	70.40
113	630	8	6.30	31	195.30	133	630	8	6.30	31	195.30	157	160	8	2.20	42	92.40	178	160	8	2.20	42	92.40
114	320	10	3.50	67	234.50	134	1050	12	10.50	64	672.00	179	180	8	2.40	42	100.80	179	180	8	2.40	42	100.80
115	600	10	6.00	66	396.00	135	735	12	8.00	64	512.00	180	630	8	6.30	42	264.60	180	630	8	6.30	42	264.60
116	1170	10	12.00	68	816.00	136	570	12	6.00	64	384.00	181	560	8	6.50	21	136.50	181	560	8	6.50	21	136.50
117	600	10	6.00	67	402.00	137	600	10	6.00	67	402.00	182	350	8	3.50	33	115.50	182	350	8	3.50	33	115.50
118	500	8	5.00	66	330.00	138	350	8	3.50	33	115.50	183	750	12	7.50	64	480.00	183	750	12	7.50	64	480.00
119	450	8	4.50	67	301.50	139	750	12	7.50	64	480.00	184	235	12	3.00	64	192.00	184	235	12	3.00	64	192.00
120	1050	12	10.50	66	693.00	140	1050	12	10.50	24	252.00	185	1050	12	10.50	24	252.00	185	1050	12	10.50	24	252.00
121	1170	12	12.00	66	792.00	141	320	10	3.50	67	234.50	186	320	8	3.20	34	108.80	186	320	8	3.20	34	108.80
122	750	12	7.50	66	495.00	142	570	12	6.00	64	384.00	187	570	12	6.00	64	384.00	187	570	12	6.00	64	384.00
123	235	12	3.00	66	198.00	143	1050	12	10.50	24	252.00	188	320	8	3.20	33	105.60	188	320	8	3.20	33	105.60
124	735	12	8.00	24	192.00	144	320	8	3.20	34	108.80	189	535	12	6.00	62	372.00	189	535	12	6.00	62	372.00
125	1050	12	10.50	29	304.50	145	320	8	3.20	33	105.60	190	1050	12	10.50	62	651.00	190	1050	12	10.50	62	651.00
126	750	8	7.50	24	180.00	146	535	12	6.00	62	372.00	191	1050	12	10.50	62	651.00	191	1050	12	10.50	62	651.00
127	350	8	3.50	13	45.50	147	465	12	5.00	62	310.00	192	240	12	3.00	62	186.00	192	240	12	3.00	62	186.00
128	235	8	3.00	24	72.00	148	235	8	3.00	24	72.00	193	465	12	5.00	62	310.00	193	465	12	5.00	62	310.00
129	50	8	3.00	24	72.00	149	235	8	3.00	24	72.00	194	240	12	3.00	62	186.00	194	240	12	3.00	62	186.00

TABELA E SPECIFIKIMIT TE ARMATURES NE KUOTEN +11.27 m











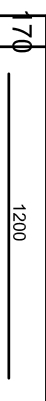

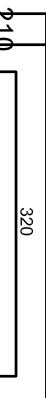

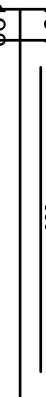
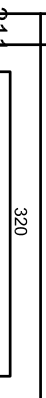

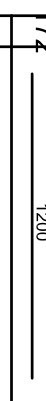

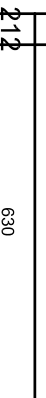
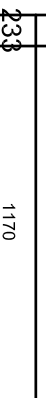

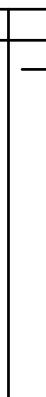
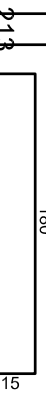
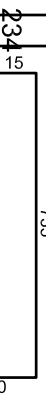
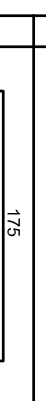

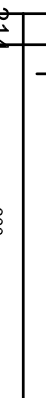





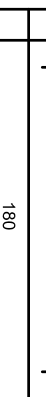
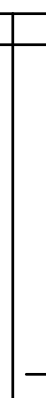
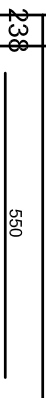
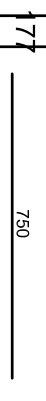

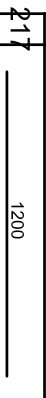
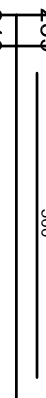

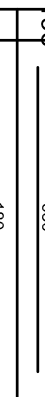
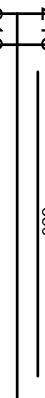
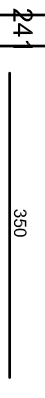

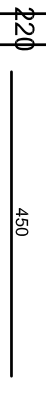

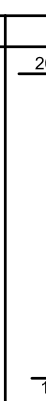

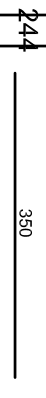



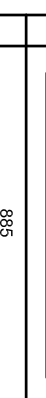
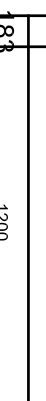



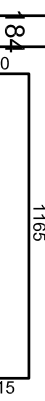
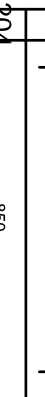

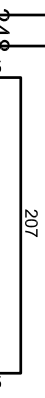

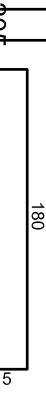
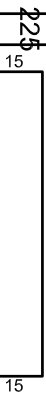

170		8	12.00	31	372.00	190		8	3.50	22	77.00	210		10	3.50	32	112.00	231		8	3.50	14	49.00
171		12	12.00	31	372.00	191		8	3.50	58	203.00	211		10	3.50	33	115.50	232		8	2.40	27	64.80
172		12	12.00	31	372.00	192		8	3.50	16	56.00	212		8	6.30	31	195.30	233		8	11.70	27	315.90
173		8	9.00	23	207.00	193		8	2.40	31	74.40	213		8	2.40	31	74.40	234		8	8.00	27	216.00
174		8	6.50	23	149.50	194		10	3.50	31	108.50	214		8	3.00	33	99.00	235		8	5.50	27	148.50
175		8	2.40	23	55.20	195		8	3.50	16	56.00	215		10	2.40	64	153.60	236		8	5.00	27	135.00
176		12	3.00	64	192.00	196		10	3.50	31	108.50	216		10	6.00	64	384.00	237		8	5.00	27	135.00
177		12	7.50	64	480.00	197		8	2.40	31	74.40	217		8	12.00	40	480.00	238		8	5.50	28	154.00
178		12	5.00	64	320.00	198		8	6.30	62	390.60	218		8	3.50	16	56.00	239		8	5.00	28	140.00
179		12	8.00	48	384.00	199		8	2.40	62	148.80	219		8	3.50	16	56.00	240		8	3.50	32	112.00
180		12	7.50	48	360.00	200		8	3.50	32	112.00	220		8	4.50	21	94.50	241		8	3.50	31	108.50
181		8	9.00	49	441.00	201		8	3.50	62	217.00	221		8	5.50	26	143.00	242		8	3.50	24	84.00
182		8	12.00	49	588.00	202		8	3.50	16	56.00	222		8	3.00	33	99.00	243		8	3.50	32	112.00
183		8	12.00	49	588.00	203		8	4.50	31	139.50	223		10	2.40	64	153.60	244		8	3.50	31	108.50
184		8	12.00	31	372.00	204		8	8.50	31	263.50	224		10	6.00	64	384.00	245		8	3.50	33	115.50
185		8	6.50	31	201.50	205		8	2.40	31	74.40	225		12	5.00	53	265.00	246		12	9.15	15	137.25
186		8	2.40	31	74.40	206		8	9.00	44	396.00	226		12	8.00	30	240.00	247		12	9.00	15	135.00
187		8	6.50	29	188.50	207		8	9.00	44	396.00	227		12	6.00	30	180.00	248		12	4.50	62	279.00
188		8	2.40	29	69.60	208		8	2.40	31	74.40	228		8	3.50	15	52.50	249		12	4.50	62	279.00
189		8	3.50	42	147.00	209		8	6.30	31	195.30	229		8	3.00	30	90.00	250		8	7.50	30	225.00
				Total						39994.55													

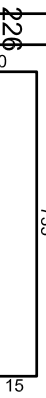
TABELA PERMBLEDHESE E ARMATURES

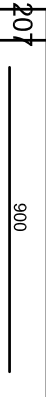
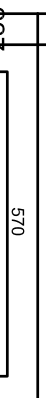
Ø [mm]	l [m]	PESHA NJESI [kg/ml]	PESHA [kg]
Armimi i Soletes, Kuota +11.27 m			
8	26546.60	0.40	10485.91
10	5925.00	0.62	3655.72
12	29113.65	0.89	25852.92
Total			39994.55

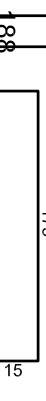
ARMIMI I PARAPETEVE

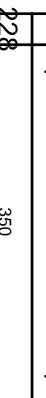
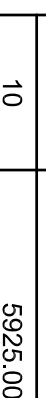
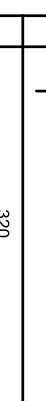
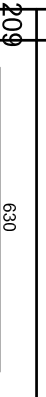
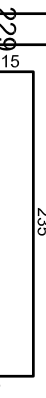
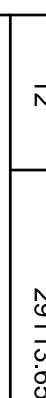
(PARAPET 20 cm MBI SOLETE)

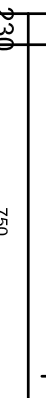
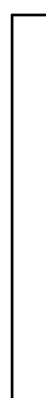
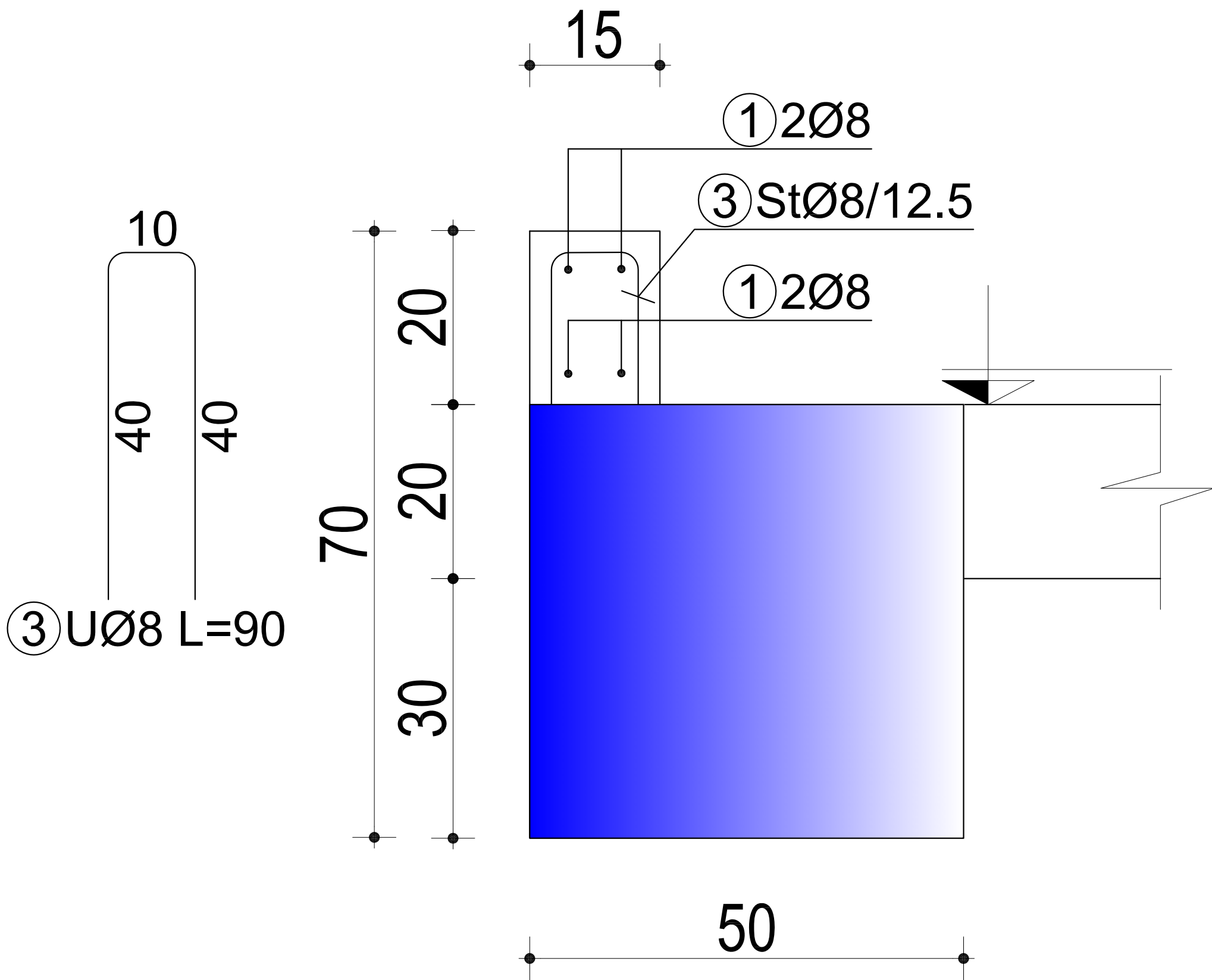

SHENIME TEKNIKE:
BETONI: B-30 (M-300)
HEKURI: S500 OSE EKUIVALENT

OBJEKTI:			
EMERTIMI:	ARMIMI I PARAPETEVE		
KONSTRUKTOR	DHIMITER PAPA	K.1510/2	
KONSTRUKTOR			Nr Fletes
KONSTRUKTOR			K-207
FAZA E PROJEKTIT	<input type="checkbox"/> PROJEKT IDE	<input checked="" type="checkbox"/> PROJEKT ZBATIM	Dt.
POSITITI:			

HOLLESI TE ARMIMIT TE SOLETAVE MONOLITE

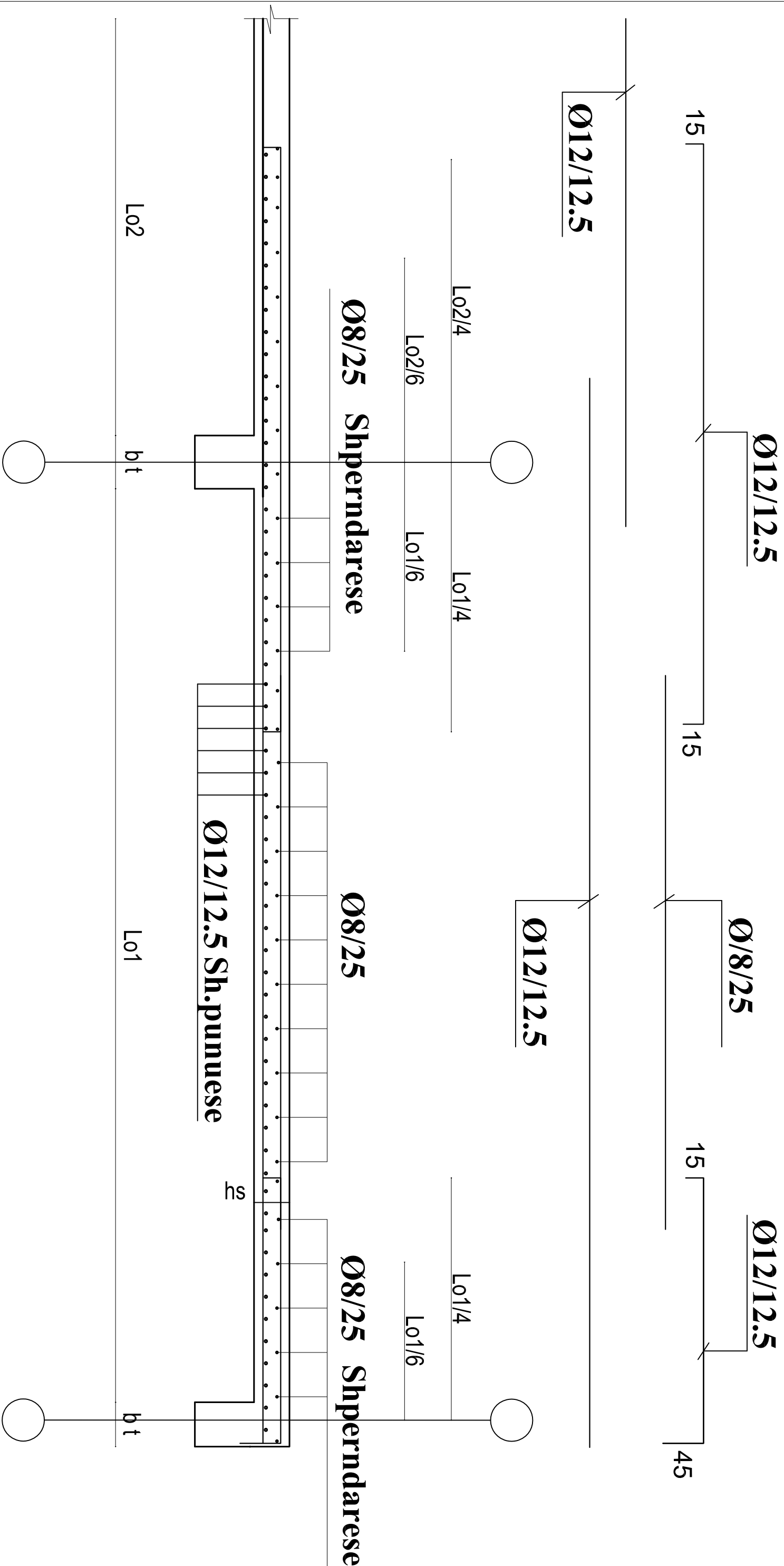

SHENIME TEKNIKE:
BETONI: C 30/37
HEKURI: S500 OSE EKVIVALENT

OBJEKTI	
EMERTIMI: HOLLESI TE ARMIMIT TE SOLETAVE MONOLITE	
KONSTRUKTOR	
KONSTRUKTOR	
KONSTRUKTOR	
FAZA E PROJEKTT	
<input type="checkbox"/> PROJEKT IDE	<input checked="" type="checkbox"/> PROJEKT ZBATIM
DI.	

PLANIMETRIA E SHKALLES

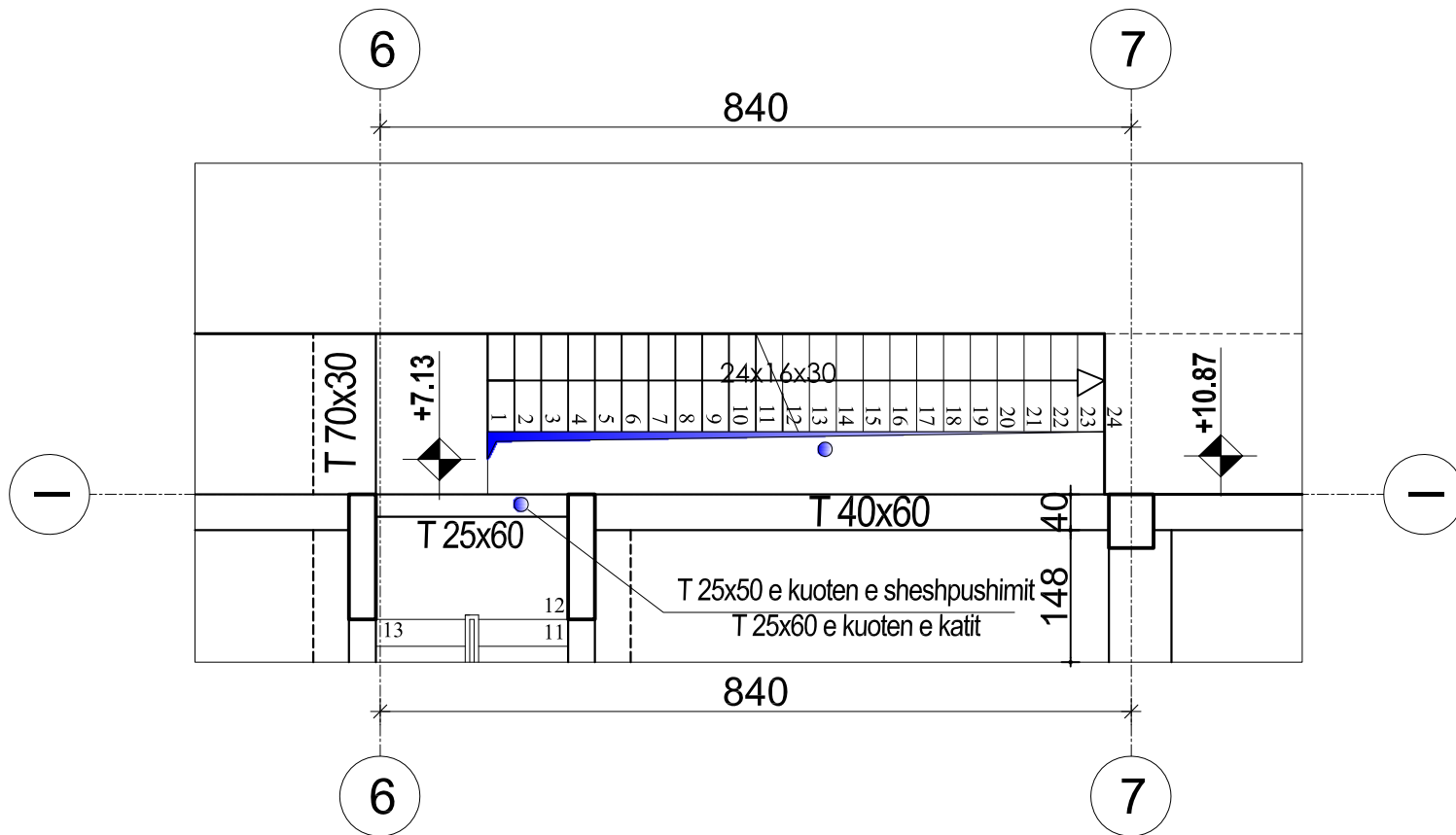

PRERJA A-A ARMIMI I SHKALLES



TABELA E SPECIFIKIMIT TE ARMATURES					
Nr.	FORMA DHE PERMASAT [cm]	Ø [mm]	l [m]	n [cople]	l(totale) [m]
Armimi i shkalles (1 ml)					
1		14	12.00	10	120.00
2		14	3.00	10	30.00
3		14	3.00	10	30.00
4		14	12.00	10	120.00



PLANIMETRIA E SHKALLES

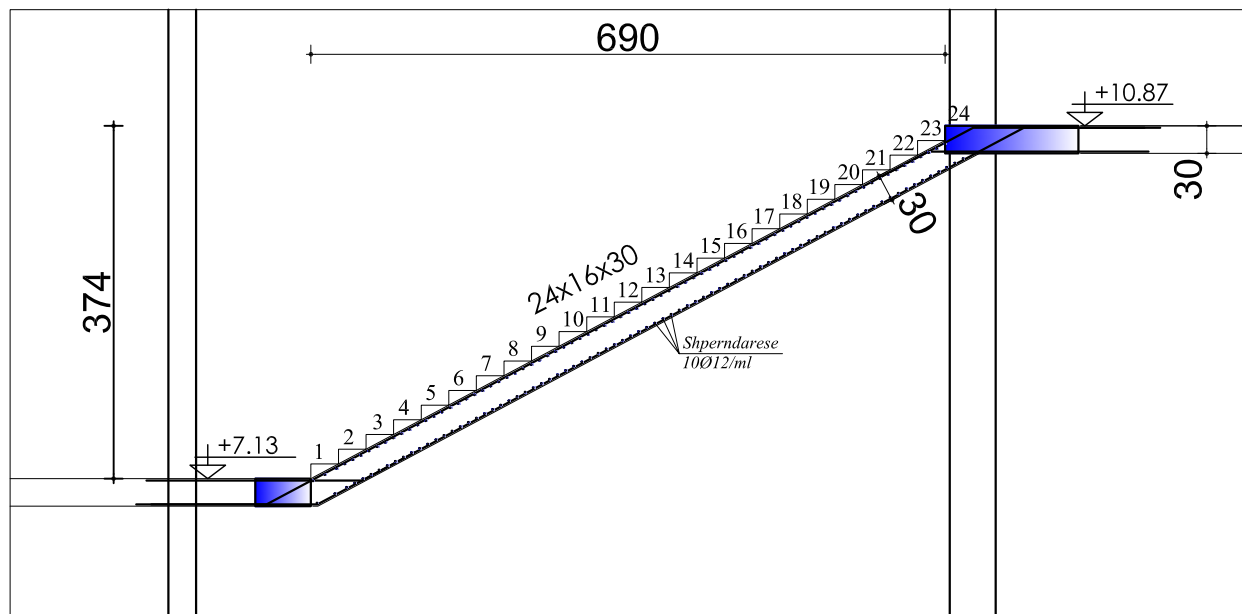
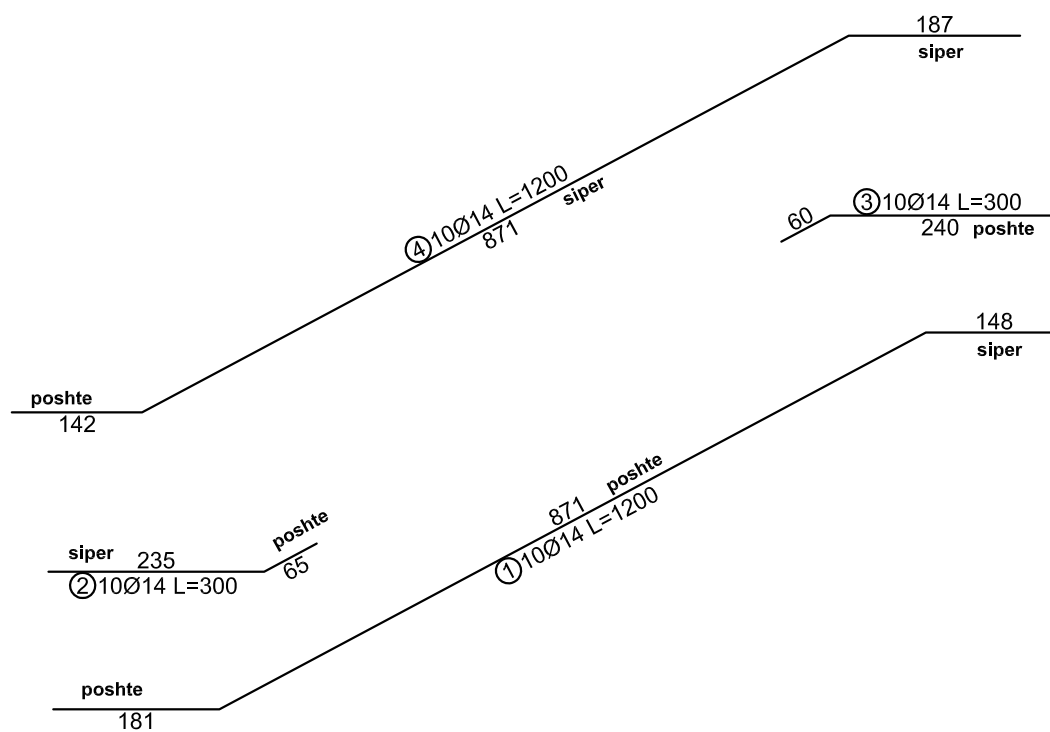
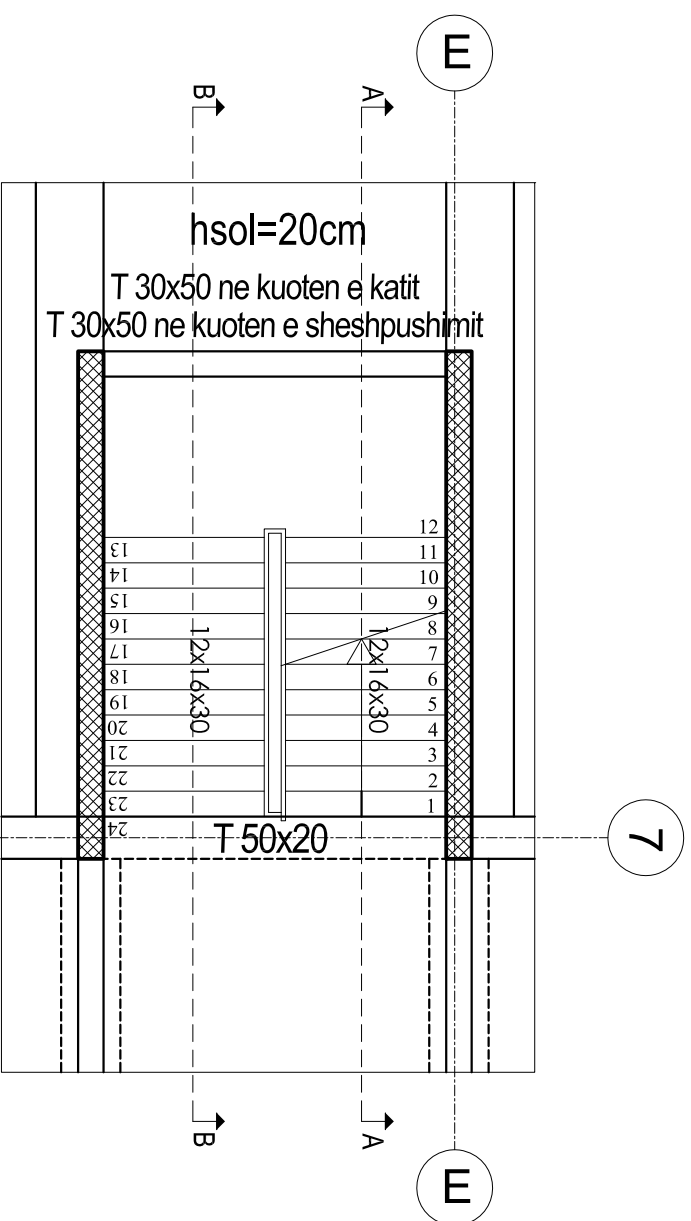

PRERJA A-A
ARMIMI I SHKALLES

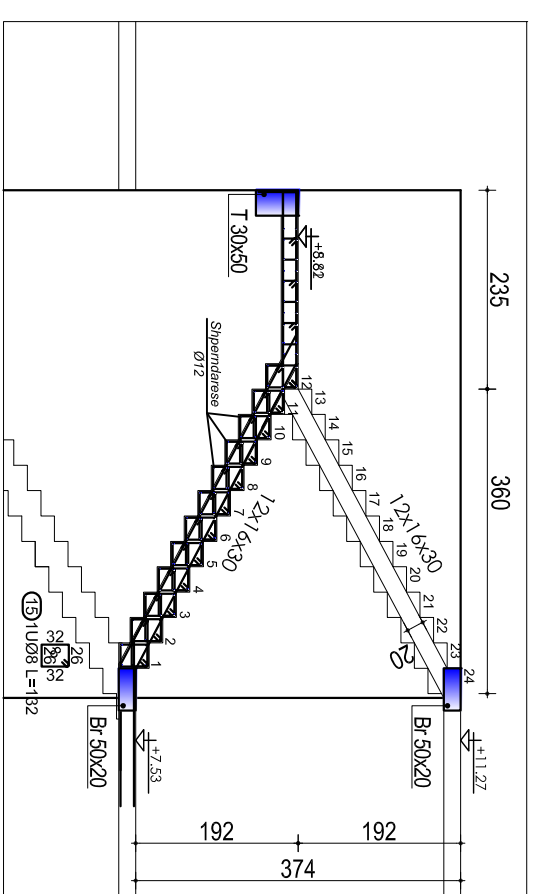

PRERJA B-B
ARMIMI I SHKALLES



TABELA E SPECIFIKIMIT TE ARMATURES					
Nr	FORMA DHE PERMASAT [cm]	Ø [mm]	l [m]	n [copë]	(totale) [m]
Armimi i shkalles (1 ml)					
1		12	6.70	10	67.00
2		12	2.40	10	24.00
3		12	3.00	10	30.00
4		12	7.80	10	78.00
5		12	8.00	10	80.00
6		12	3.70	10	37.00
7		12	2.40	10	24.00
8		12	6.60	10	66.00
9		12	2.47	10	24.70
10		12	2.76	10	27.60
11		8	1.38	10	13.80
12		8	1.66	10	16.60
13		8	5.10	10	51.00
14		8	0.98	10	9.80
15		8	1.32	10	13.20

SHENIME TEKNIKE:

BETONI: C 30/37
 HEKURI: S500 OSE EKUIVALENT
 ARMATURA E SHKALLES: JEPET PER 1 ml
 SHUFRAI SHPERNDARËSE Ø12
 TE INKASTROHEN NE MURET B/A.

OBJEKTI	
DIREKTOR ARCHITECTURIS	
KONSTRUKTOR	DIMITER PAPA
KONSTRUKTOR	K.15102
KONSTRUKTOR	Nr Fshes
Projekti i/a	<input type="checkbox"/> Projekti i/a
Projekti i/a	<input checked="" type="checkbox"/> Projekti i/a
FORSHIRI:	Dt. K-210

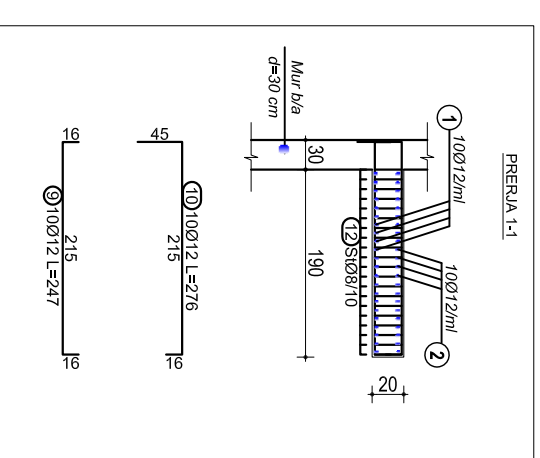
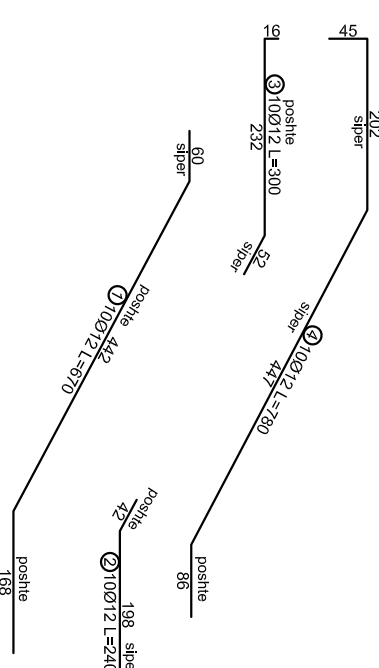
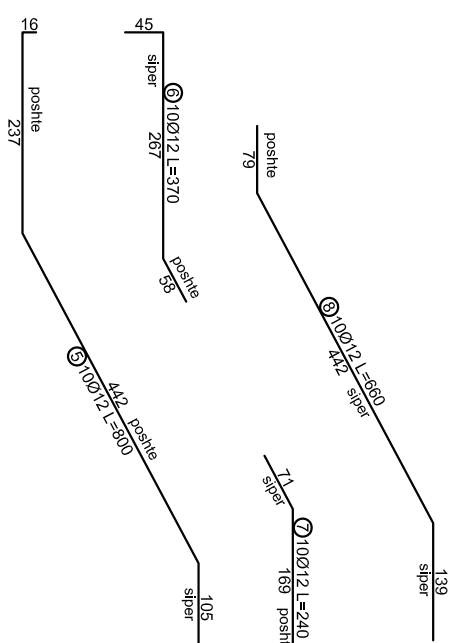
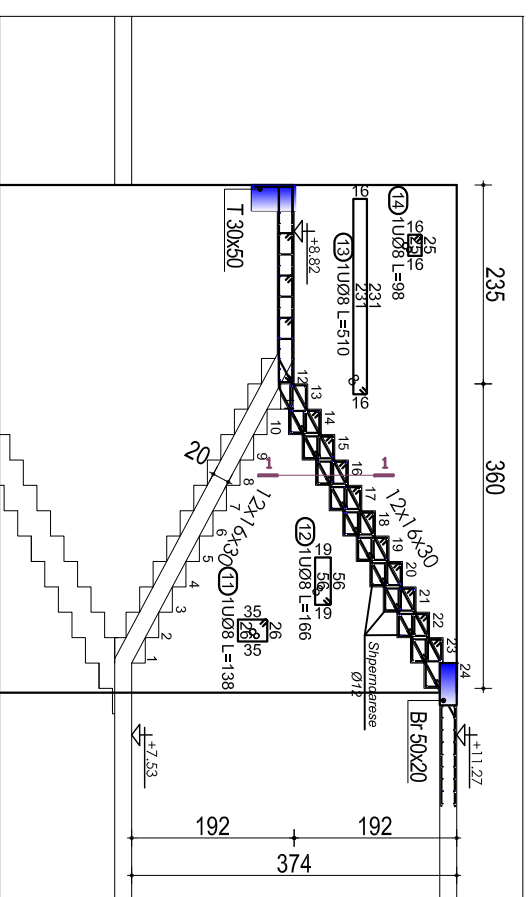
ARMIMI I TRAUT NE AKSIN A, KUOTA +11.27 m



TABELA E SPECIFIKIMIT TE ARMATURES

Nr.	FORMA DHE PERMASAT [cm]	Ø	l [m]	n [coppe]	l (totale) [m]
Traut ne aksin A, kuota +11.27 m (1 pcs.)					
1	935	20	9.80	6	58.80
2	950	20	9.50	6	57.00
3	1200	22	12.00	6	72.00
4	900	16	9.00	7	63.00
5	950	20	9.50	7	66.50
6	950	20	9.50	7	66.50
7	935	20	9.80	7	68.60
8	600	22	6.00	2	12.00
9	400	22	4.00	2	8.00
10	600	22	6.00	2	12.00
11	400	22	4.00	2	8.00
12	700	25	7.00	2	14.00
13	500	25	5.00	2	10.00
14	600	22	6.00	2	12.00
15	400	22	4.00	2	8.00
16	600	22	6.00	2	12.00
17	400	22	4.00	2	8.00
18	600	22	6.00	2	12.00
19	400	22	4.00	2	8.00
20	455	16	5.00	2	10.00
21	1200	20	12.00	2	24.00
22	1200	20	12.00	2	24.00
23	1200	16	12.00	2	24.00
24	1200	16	12.00	2	24.00

25	1155	16	12.00	2	24.00
26	1155	20	12.00	2	24.00
27	1200	20	12.00	2	24.00
28	1200	20	12.00	2	24.00
29	1200	16	12.00	2	24.00
30	1200	16	12.00	2	24.00
31	455	16	5.00	2	10.00
32	355	22	4.00	4	16.00
33	600	22	6.00	4	24.00
34	700	22	7.00	4	28.00
35	1400	22	14.00	4	56.00
36	600	22	6.00	4	24.00
37	600	22	6.00	4	24.00
38	305	22	3.50	4	14.00
39	45	8	1.86	78	145.08
40	45	10	1.86	398	740.28
41	45	10	1.66	448	743.68
42	45	8	1.86	60	111.60

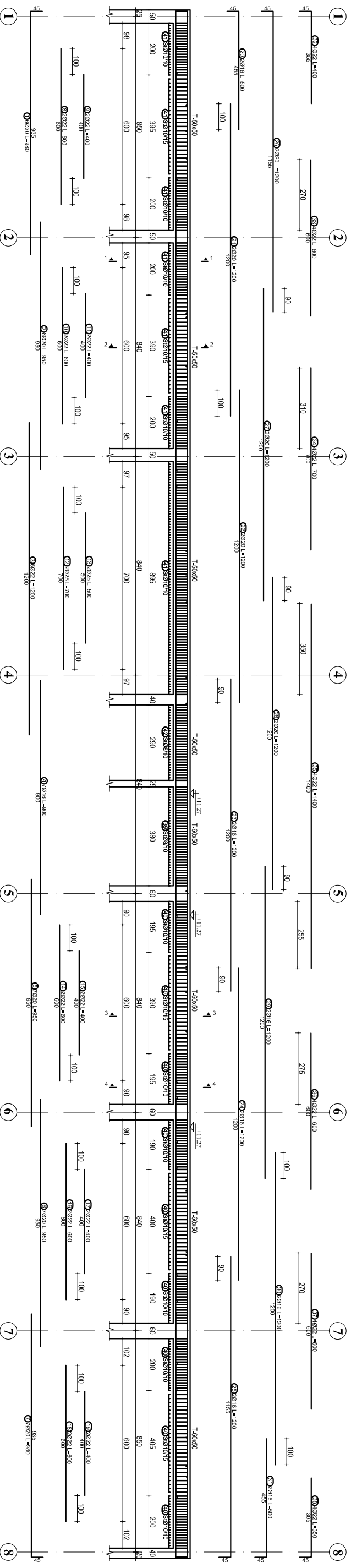
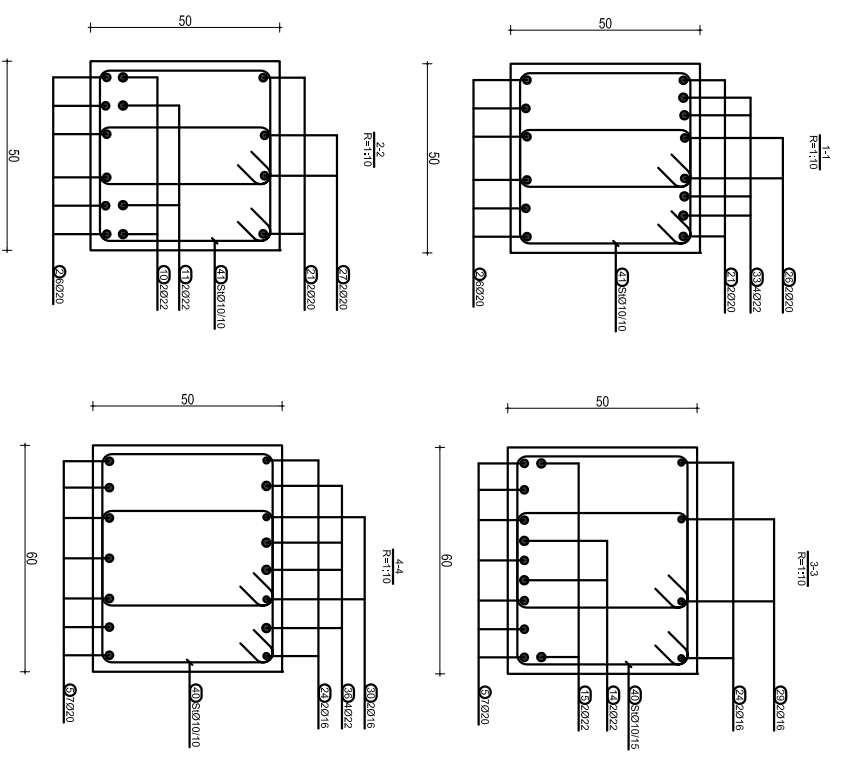

SHENIME TEKNIKE:
 BETONI: C30/37
 HEKURI: S500 OSE EKUIVALENT

OBJEKTI:	
EMERTIMI: ARMIMI I TRAVEVE, KUOTA +11.27 m	
KONSTRUKTOR	DHIMITER PAPA
KONSTRUKTOR	
KONSTRUKTOR	
	Ni. Fletis
	K-213
	Dl.

ARMIMI I TRAUT NE AKSIN B, KUOTA +11.27 m



TABELA E SPECIFIKIMIT TE ARMATURES

Nr.	FORMA DHE PERMASAT [cm]	Ø	l [m]	n [copel]	l(totale) [m]
Trau ne aksin B, kuota +11.27 m (1 pcs.)					
1	935	20	9.80	6	58.80
2	950	20	9.50	6	57.00
3	1200	22	12.00	6	72.00
4	900	16	9.00	6	54.00
5	940	20	9.40	6	56.40
6	950	20	9.50	6	57.00
7	935	20	9.80	6	58.80
8	600	22	6.00	2	12.00
9	400	22	4.00	2	8.00
10	600	22	6.00	2	12.00
11	400	22	4.00	2	8.00
12	700	25	7.00	2	14.00
13	500	25	5.00	2	10.00
14	600	22	6.00	2	12.00
15	400	22	4.00	2	8.00
16	600	22	6.00	2	12.00
17	400	22	4.00	2	8.00
18	600	22	6.00	2	12.00
19	400	22	4.00	2	8.00
20	455	16	5.00	2	10.00
21	1200	16	12.00	2	24.00
22	1200	20	12.00	2	24.00

23	1200	16	12.00	2	24.00
24	1200	16	12.00	2	24.00
25	1155	16	12.00	2	24.00
26	1155	16	12.00	2	24.00
27	1200	20	12.00	2	24.00
28	1200	20	12.00	2	24.00
29	1200	16	12.00	2	24.00
30	1200	16	12.00	2	24.00
31	455	16	5.00	2	10.00
32	355	22	4.00	4	16.00
33	600	22	6.00	4	24.00
34	700	22	7.00	4	28.00
35	1400	22	14.00	4	56.00
36	600	22	6.00	4	24.00
37	600	22	6.00	4	24.00
38	305	22	3.50	4	14.00
39	45	8	1.86	78	145.08
40	45	10	1.66	848	1407.68
41	45	8	1.86	60	111.60

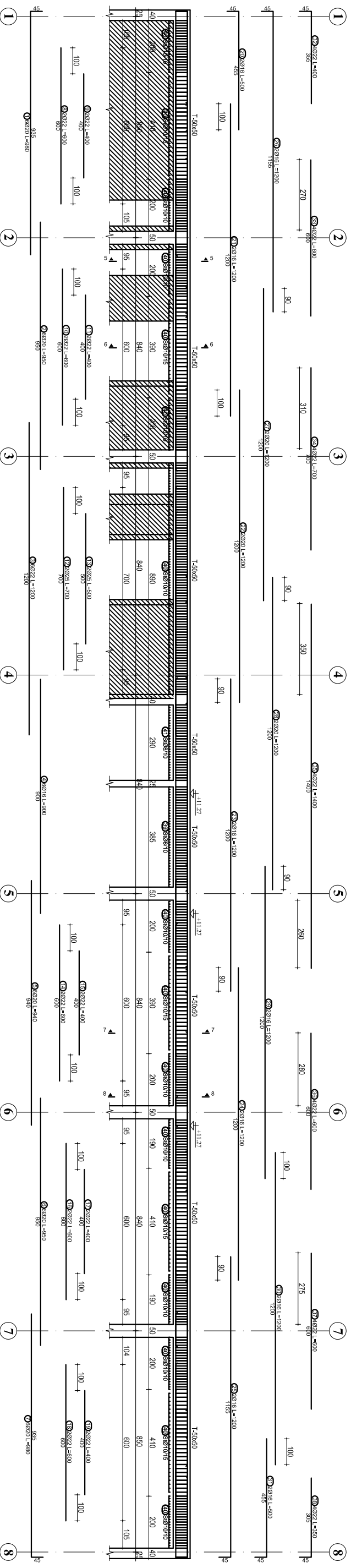
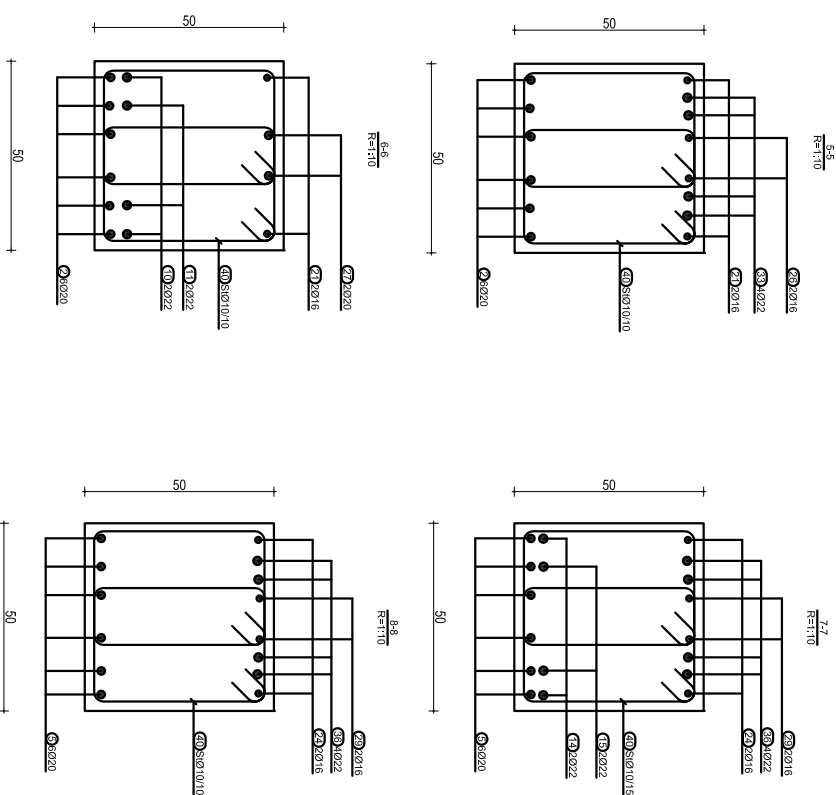

SHENIME TEKNIKE:
 BETONI: C30/37
 HEKURI: S500 OSE EKUIVALENT

OBJEKTI:	
EMERTIMI: ARMIMI I TRAVEVE, KUOTA +11.27 m	
KONSTRUKTOR	DHIMITER PAPA
KONSTRUKTOR	
KONSTRUKTOR	
	Nr. Fielis
	K-214
	Dl.

ARMIMI I TRAUT MBI AKSIN B(4-8), KUOTA +1.27 m



TABELA E SPECIFIKIMIT TE ARMATURES

Nr.	FORMA DHE PERMASAT [cm]	Ø	l [m]	n [copel]	l(totale) [m]
1	835	14	8.50	7	59.50
2	950	14	9.50	7	66.50
3	950	14	9.50	7	66.50
4	1005	14	10.20	7	71.40
5	500	14	5.00	2	10.00
6	600	14	6.00	2	12.00
7	600	14	6.00	2	12.00
8	600	14	6.00	2	12.00

9	55	14	12.00	4	48.00
10	1200	14	12.00	4	48.00
11	1155	14	12.00	4	48.00
12	545	14	6.00	4	24.00
13	900	14	9.00	4	36.00
14	600	14	6.00	4	24.00
15	1200	14	12.00	4	48.00
16	405	14	4.50	4	18.00
17	40	8	1.26	624	786.24

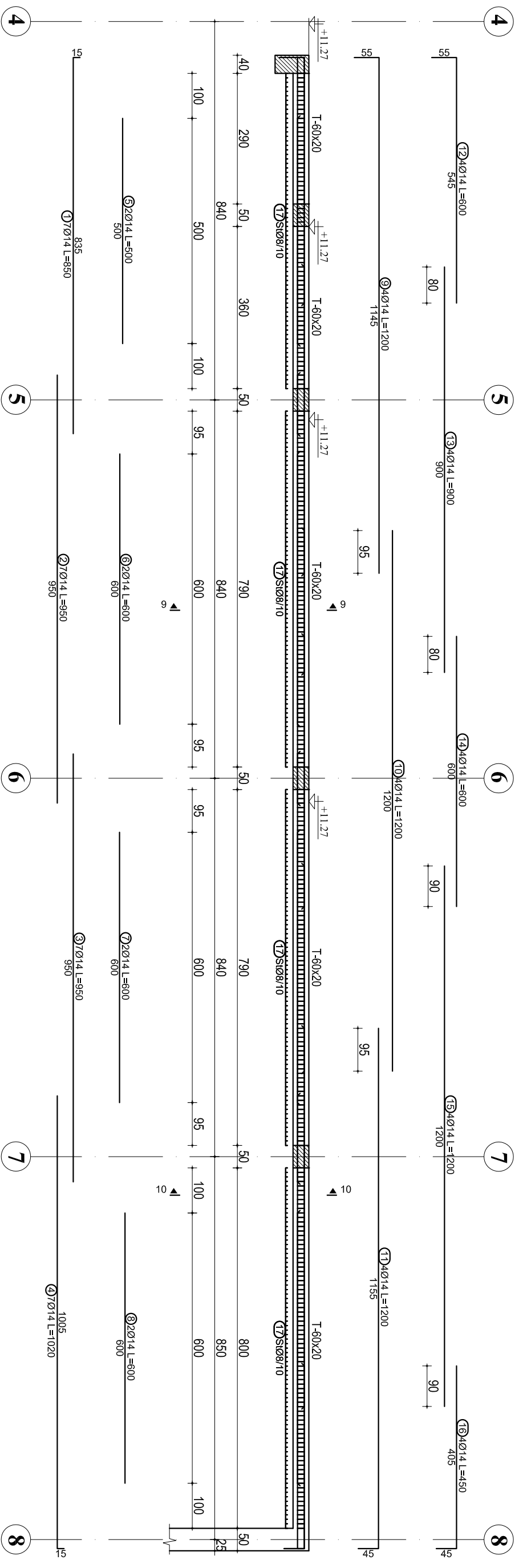
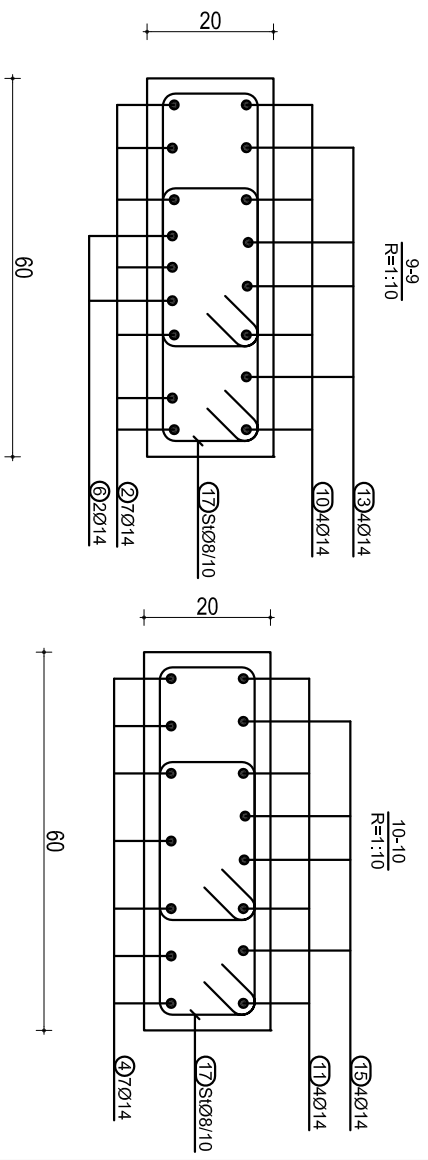

OBJEKTI:
 EMERTIMI: ARMIMI I TRAVEVE, KUOTA +1.27 m
 KONSTRUKTOR: **DHIMITER PAPA** K.15/10/2
 SHENIME TEKNIKE:
 BETONI: C30/37
 HEKURI: S500 OSE EKUIVALENT
 KONSTRUKTOR: **K-215**
 Dl.

ARMIMI I TRAUT NE AKSIN D, KUOTA +11.27 m



TABELA E SPECIFIKIMIT TE ARMATURES

Nr.	FORMA DHE PERMASAT [cm]	Ø [m]	l [m]	n [kopje]	(totalet) [m]
Trau ne aksin D, kuota +11.27 m (1 pcs.)					
1	705	16	7.50	7	52.50
2	1200	22	12.00	7	84.00
3	950	20	9.50	6	57.00
4	950	20	9.50	6	57.00
5	950	20	9.50	6	57.00
6	935	20	9.80	6	58.80
7	910	20	10.00	6	60.00
8	350	20	3.50	2	7.00
9	800	25	8.00	2	16.00
10	600	25	6.00	2	12.00
11	600	22	6.00	2	12.00
12	400	22	4.00	2	8.00
13	600	22	6.00	2	12.00
14	400	22	4.00	2	8.00
15	600	22	6.00	2	12.00
16	400	22	4.00	2	8.00
17	600	22	6.00	2	12.00
18	400	22	4.00	2	8.00
19	600	22	6.00	2	12.00
20	400	22	4.00	2	8.00
21	1155	22	12.00	2	24.00
22	1200	22	12.00	2	24.00
23	1200	20	12.00	2	24.00
24	1200	20	12.00	2	24.00

25	755	20	8.00	2	16.00				
26	910	20	10.00	4	40.00				
27	755	20	8.00	2	16.00				
28	1191	22	11.91	2	23.82				
29	1200	22	12.00	2	24.00				
30	1200	20	12.00	2	24.00				
31	1155	20	12.00	2	24.00				
32	255	20	3.00	4	12.00				
33	800	22	8.00	4	32.00				
34	900	22	9.00	4	36.00				
35	600	20	6.00	4	24.00				
36	600	20	6.00	4	24.00				
37	600	20	6.00	4	24.00				
38	325	20	3.70	4	14.80				
39	355	20	4.00	4	16.00				
40	355	20	4.00	4	16.00				
41	45	8	1.86	88	163.68				
42	45	12	1.90	200	380.00				
43	45	10	1.56	524	869.84				
44	45	10	1.50	134	201.00				

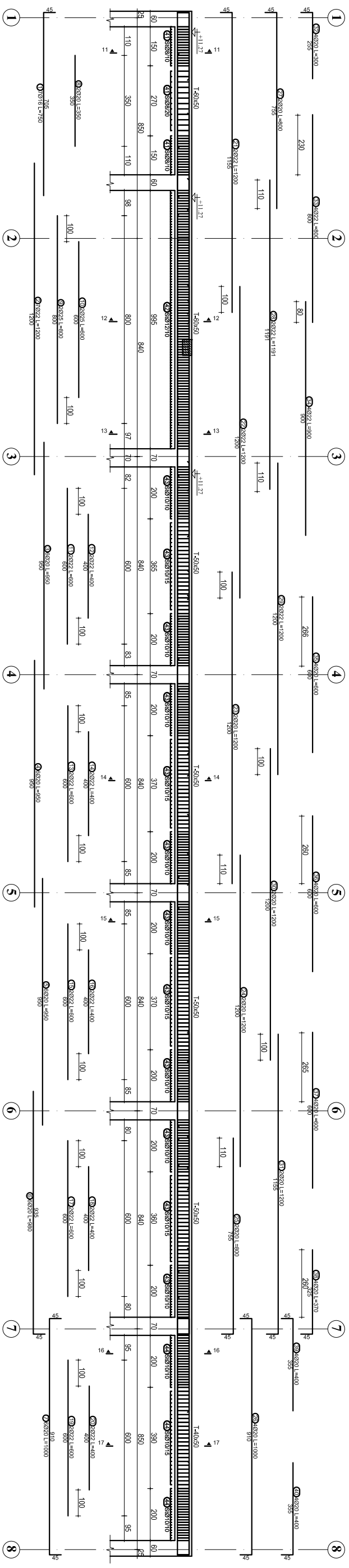
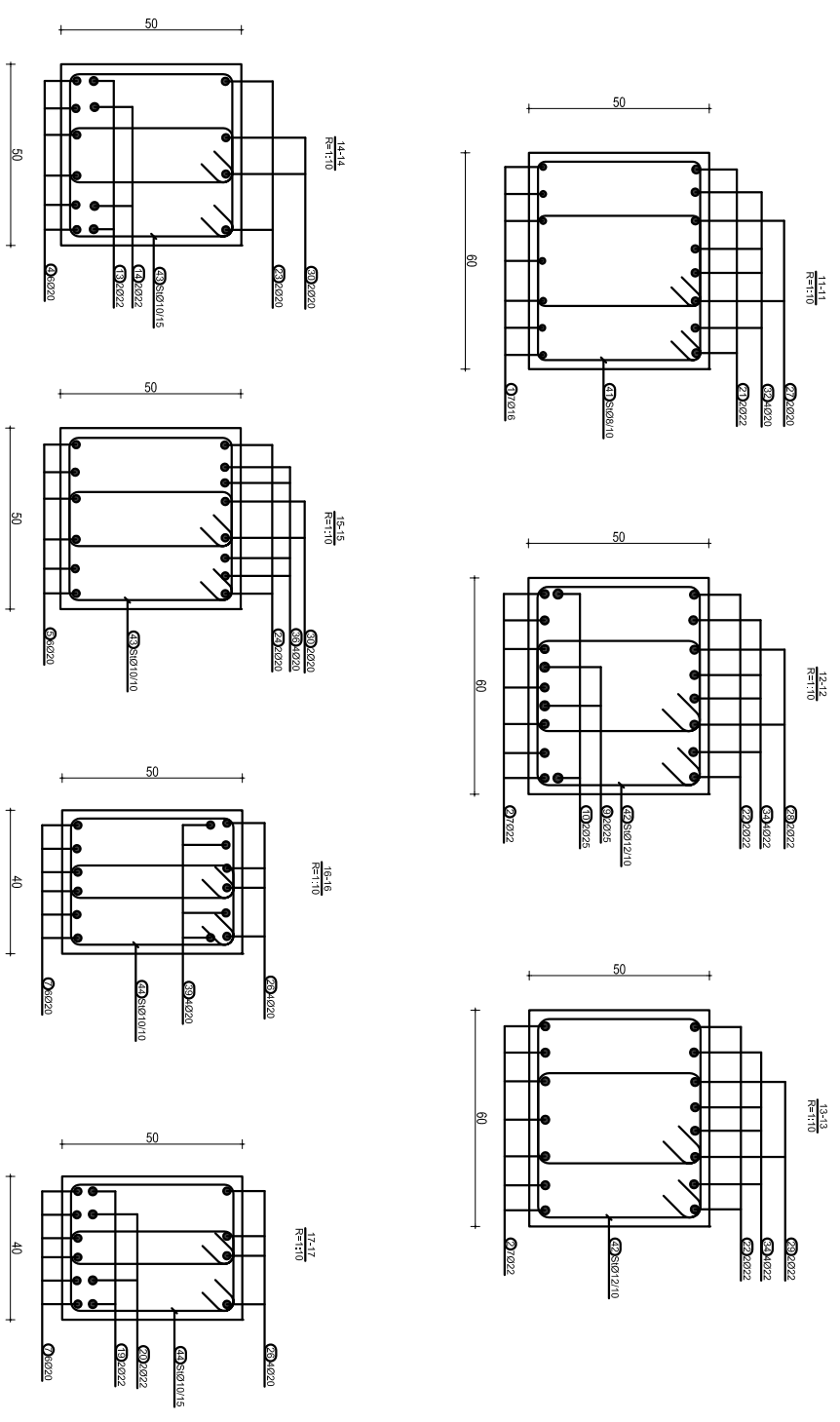

SHENIME TEKNIKE:
BETONI: C30/37
HEKURI: S500 OSE EKUIVALENT

OBJEKTI:	
EMERTIMI:	ARMIMI I TRAVEVE, KUOTA +11.27 m
KONSTRUKTOR:	DHIMITER PAPA
KONSTRUKTOR:	K.151/02
KONSTRUKTOR:	Ni. Fletos
KONSTRUKTOR:	K-216
Dl.	

ARMIMI I TRAUT MBI AKSIN D(1-3), KUOTA +11.27 m

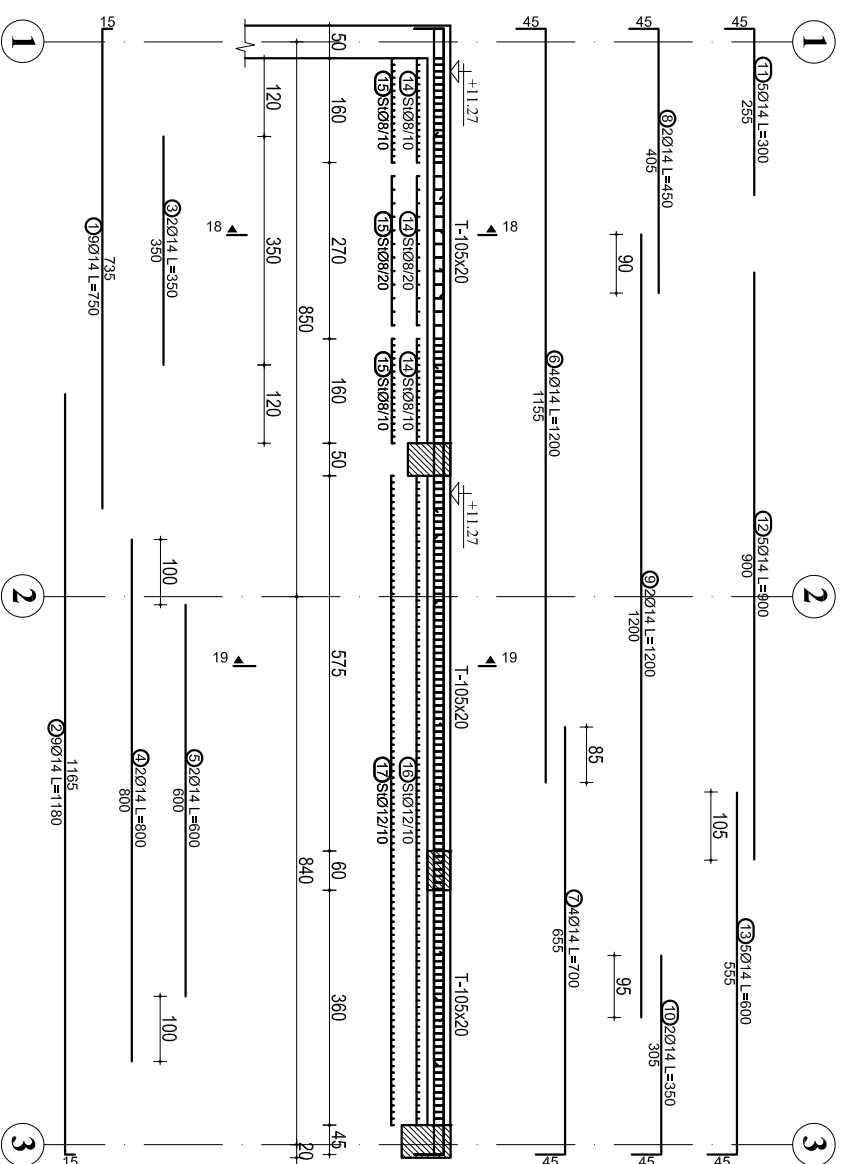

ARMIMI I TRAUT NE AKSIN E(1-3), KUOTA +11.27 m



TABELA E SPECIFIKIMIT TE ARMATURES					
Nr.	FORMA DHE PERMASAT [cm]	Ø	l	n	(kujale) [m]
Trau mbi aksin D(1-3), kuota +11.27 m (1 coppe)					
1	735	14	7.50	9	67.50
2	1165	14	11.80	9	106.20
3	390	14	3.50	2	7.00
4	800	14	8.00	2	16.00
5	600	14	6.00	2	12.00
6	1165	14	12.00	4	48.00
7	665	14	7.00	4	28.00
8	405	14	4.50	2	9.00
9	1200	14	12.00	2	24.00
10	305	14	3.50	2	7.00
11	265	14	3.00	5	15.00
12	900	14	9.00	5	45.00
13	665	14	6.00	5	30.00
14	100	8	2.46	46	113.16
15	100	8	0.86	92	79.12
16	100	12	2.50	100	250.00
17	100	12	0.90	200	180.00
Trau ne aksin E(1-3), kuota +11.27 m (1 coppe)					
1	715	14	7.50	7	52.50
2	1165	22	12.00	7	84.00
3	350	16	3.50	2	7.00
4	800	25	8.00	2	16.00
5	600	25	6.00	2	12.00
6	1165	22	12.00	2	24.00
7	665	22	7.00	2	14.00
8	665	20	7.00	2	14.00
9	1165	22	12.00	2	24.00
10	265	20	3.00	4	12.00
11	465	22	5.00	4	20.00
12	900	22	9.00	4	36.00
13	50	8	1.86	90	167.40
14	50	12	1.90	200	380.00

OBJEKTI:
EMERTIRI: ARMIMI I TRAVEVE, KUOTA +11.27 m
KONSTRUKTOR: **DHIMITER PAPA**
SHENIME TEKNIKE:
BETONI: C30/37
HEKURI: S500 OSE EKUIVALENT

KONSTRUKTOR	K.15/10/2	Nr. Fletës
KONSTRUKTOR		K-217
Dl.		

ARMIMI I TRAUT NE AKSIN F, KUOTA +1.27 m

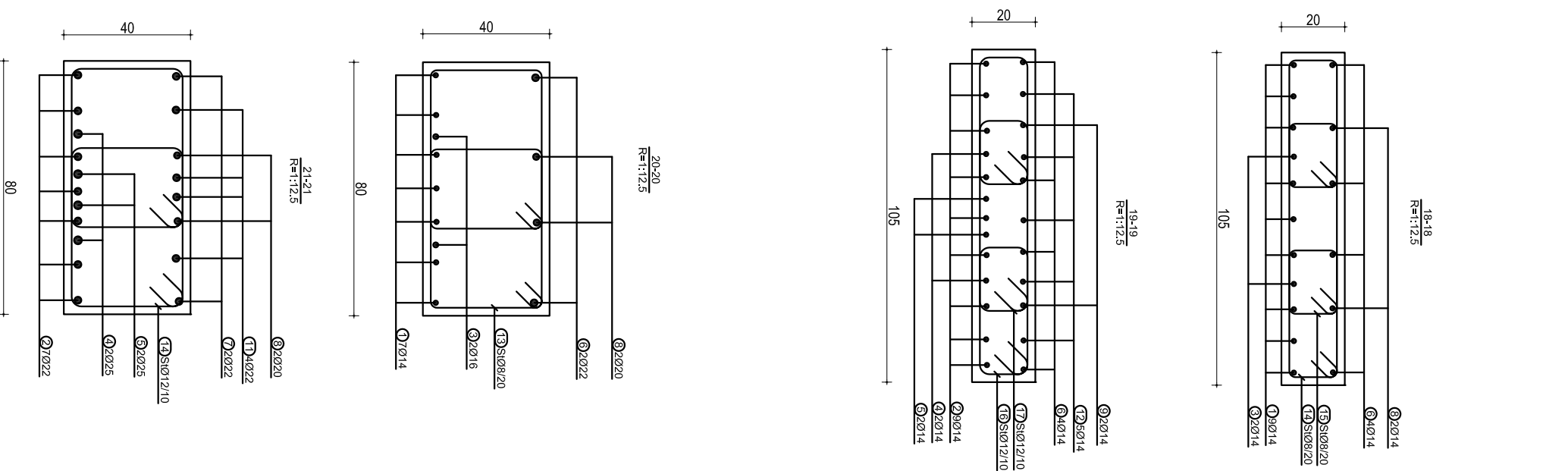
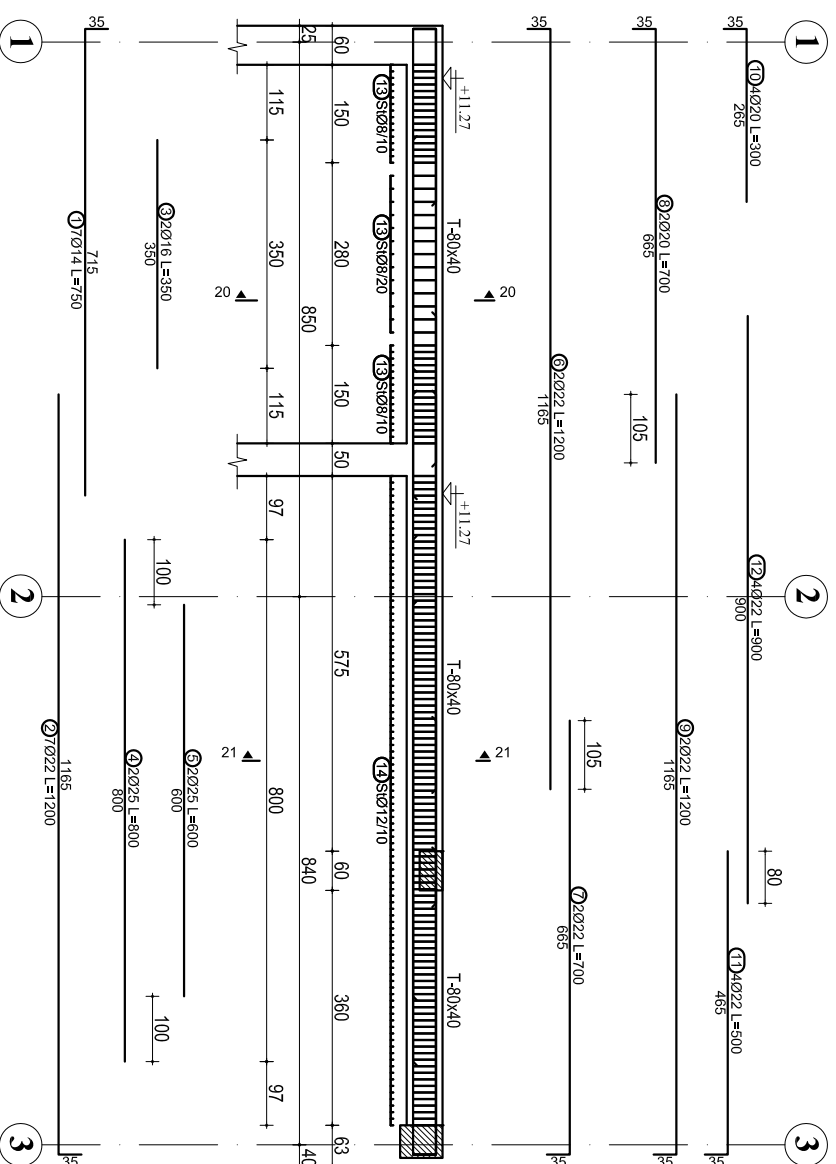
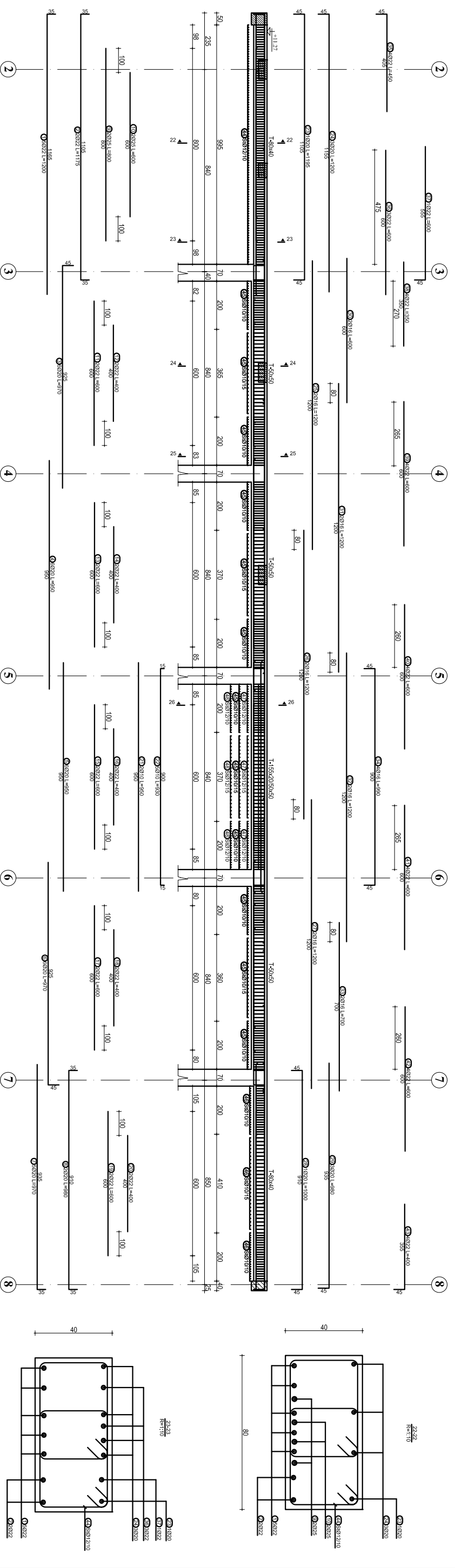

Nr.	FORMA DHE PERMASAT [cm]	Ø	l [m]	n [coppe]	lironale [m]
Traut ne aksin F, kuota +1.27 m (1 pcs.)					
1	1185	22	12.00	5	60.00
2	1175	22	11.75	2	23.50
3	825	20	9.70	6	58.20
4	950	20	9.50	6	57.00
5	950	20	9.50	6	57.00
6	925	20	9.70	6	58.20
7	535	20	9.70	5	48.50
8	910	20	9.80	2	19.60
9	800	25	8.00	2	16.00
10	600	25	6.00	2	12.00
11	600	22	6.00	2	12.00
12	400	22	4.00	2	8.00
13	600	22	6.00	2	12.00
14	400	22	4.00	2	8.00
15	600	22	6.00	2	12.00
16	400	22	4.00	2	8.00
17	600	22	6.00	2	12.00
18	400	22	4.00	2	8.00
19	600	22	6.00	2	12.00
20	400	22	4.00	2	8.00
21	950	10	9.50	2	19.00
22	300	10	3.30	5	16.50
23	1195	20	11.95	1	11.95
24	1155	20	12.00	3	36.00

25	1200	16	12.00	2	24.00
26	1200	16	12.00	2	24.00
27	1200	16	12.00	2	24.00
28	910	20	10.00	1	10.00
29	355	20	9.80	3	29.40
30	600	16	6.00	2	12.00
31	1200	16	12.00	2	24.00
32	1200	16	12.00	2	24.00
33	700	16	7.00	2	14.00
34	900	16	9.90	4	39.60
35	405	22	4.50	4	18.00
36	600	22	6.00	3	18.00
37	585	22	6.00	1	6.00
38	390	22	3.50	4	14.00
39	600	22	6.00	4	24.00
40	600	22	6.00	4	24.00
41	600	22	6.00	4	24.00
42	600	22	6.00	4	24.00
43	355	22	4.00	4	16.00
44	50	12	1.90	200	380.00
45	45	10	1.66	524	869.84
46	35	10	1.36	136	184.96
47	145	12	3.40	66	224.40
48	30	12	1.10	66	72.80

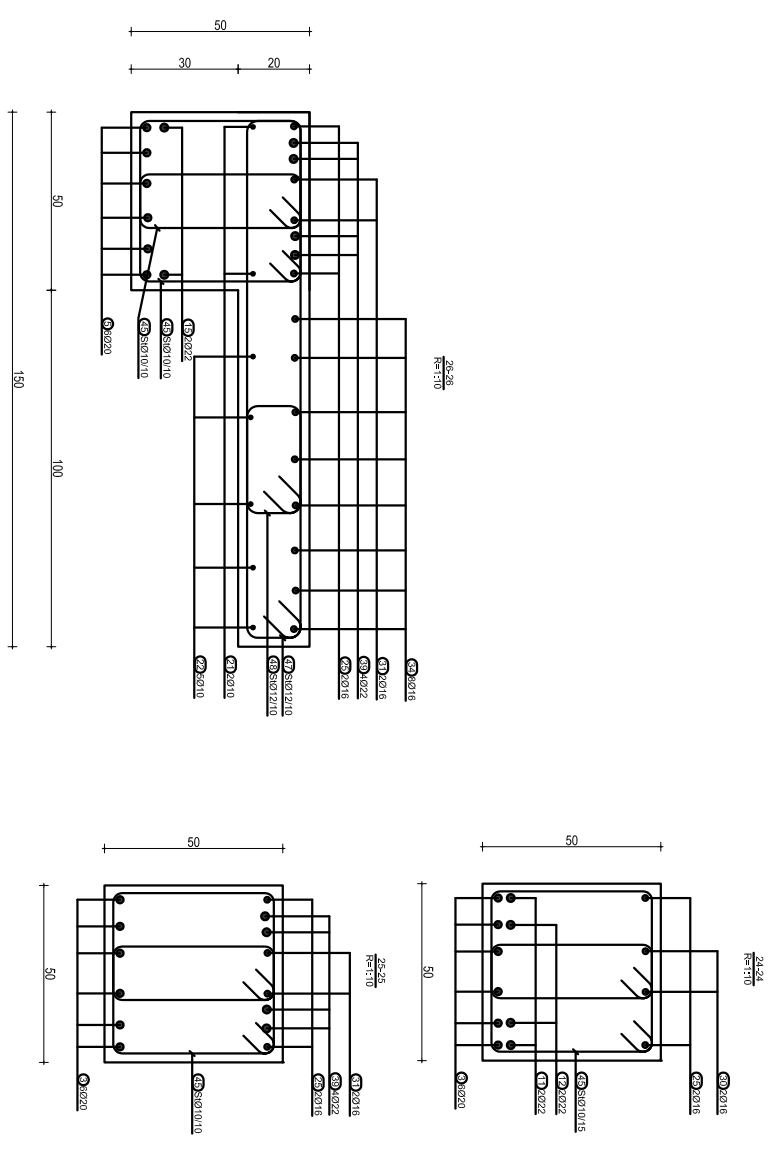

SHENIME TEKNIKE:
 BETONI: C30/37
 HEKURI: S500 OSE EKUIVALENT

OBJEKTI:	
ENERJENTI:	ARMIMI TRAPEZE, KUOTA +1.27 m
KONSTRUKTOR:	DHIMITER PAPA
KONSTRUKTOR:	
KONSTRUKTOR:	
	K.15/10/2
	Nr. Fieles
	K-218
Dl.	

ARMIMI I TRAUT NE AKSIN H, KUOTA +11.27 m



TABELA E SPECIFIKIMIT TE ARMATURES

Nr.	FORMA DHE PERMASAT [cm]	Ø	l [m]	n [coppe]	(totale) [m]
Traut ne aksin H, kuota +11.27 m (1 cope)					
1	965	22	10.00	5	50.00
2	890	22	9.60	2	19.20
3	935	20	9.80	6	58.80
4	950	20	9.50	6	57.00
5	950	20	9.50	6	57.00
6	950	20	9.50	6	57.00
7	955	16	10.00	6	60.00
8	945	22	9.80	5	49.00
9	890	22	9.60	2	19.20
10	600	22	6.00	2	12.00
11	400	22	4.00	2	8.00
12	600	22	6.00	2	12.00
13	400	22	4.00	2	8.00
14	600	22	6.00	2	12.00

15	400	22	4.00	2	8.00
16	600	22	6.00	2	12.00
17	400	22	4.00	2	8.00
18	600	22	6.00	2	12.00
19	400	22	4.00	2	8.00
20	350	16	3.50	2	7.00
21	600	22	6.00	2	12.00
22	400	22	4.00	2	8.00
23	935	20	9.80	3	29.40
24	890	20	9.80	1	9.80
25	1200	16	12.00	2	24.00
26	1200	16	12.00	2	24.00
27	950	16	9.50	2	19.00
28	1200	16	12.00	2	24.00
29	600	16	6.00	2	12.00
30	1200	16	12.00	2	24.00
31	1200	16	12.00	2	24.00
32	1200	16	12.00	2	24.00
33	450	16	4.50	2	9.00
34	890	20	9.80	1	9.80
35	955	20	10.00	3	30.00

36	305	22	3.50	4	14.00
37	355	22	4.00	1	4.00
38	400	22	4.00	3	12.00
39	350	22	3.50	4	14.00
40	600	22	6.00	4	24.00
41	600	22	6.00	4	24.00
42	600	22	6.00	4	24.00
43	750	22	7.50	4	30.00
44	300	22	3.00	4	12.00
45	355	22	4.00	1	4.00
46	350	22	3.50	3	10.50
47	355	22	4.00	4	16.00
48	45	10	1.76	328	577.28
49	45	10	1.66	534	886.44
50	45	8	1.66	134	222.44

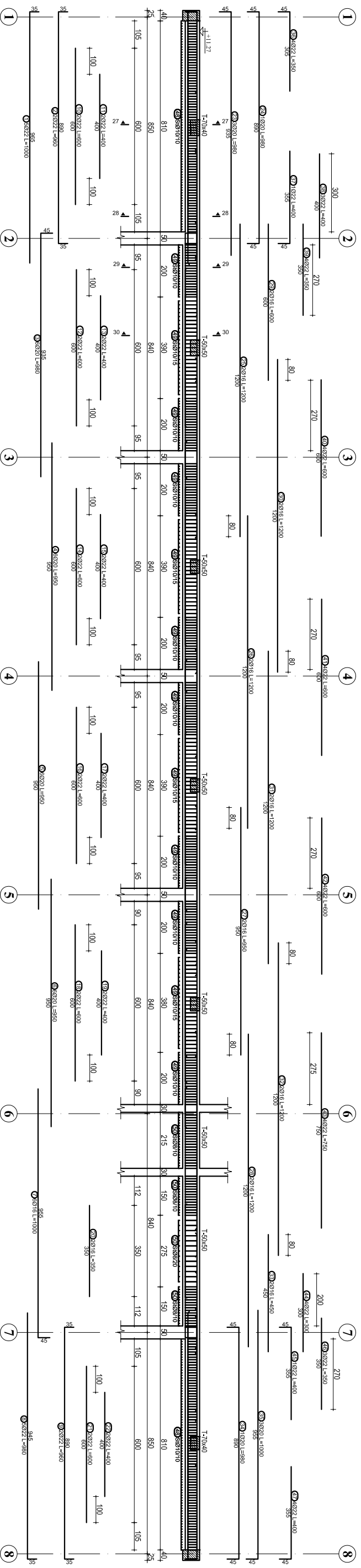
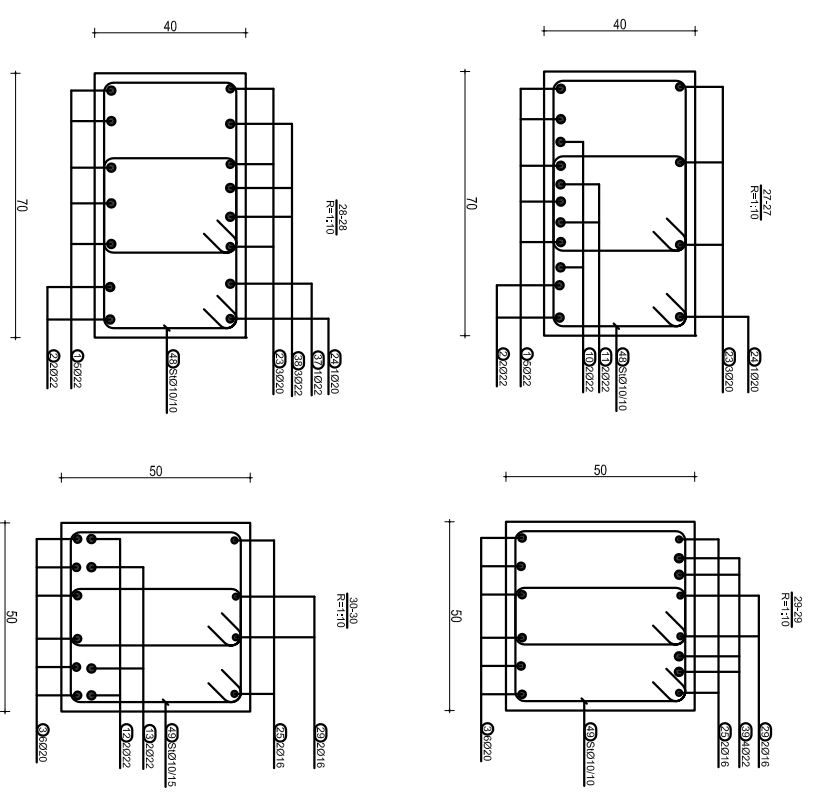

SHENIME TEKNIKE:
 BETONI: C30/37
 HEKURI: S500 OSE EKUIVALENT

OBJEKTI:	
EMERTIMI:	ARMIMI I TRAVEVE, KUOTA +11.27 m
KONSTRUKTOR:	DHIMITER PAPA
KONSTRUKTOR:	K.151/02
KONSTRUKTOR:	Ni. Fieles
KONSTRUKTOR:	K-219
Dl.	

ARMIMI I TRAUT NE AKSIN I, KUOTA +11.27 m



TABELA E SPECIFIKIMIT TE ARMATURES

Nr.	FORMA DHE PERMASAT [cm]	Ø	l [m]	n [copel]	l (totale) [m]
1	935	16	9.80	6	58.80
2	950	16	9.50	6	57.00
3	950	16	9.50	6	57.00
4	950	16	9.50	6	57.00
5	905	16	9.50	2	19.00
6	1200	16	12.00	4	48.00
7	705	16	7.50	2	15.00
8	750	16	7.50	4	30.00
9	890	16	10.20	6	61.20
10	350	16	3.50	2	7.00
11	947	10	9.80	2	19.60
12	545	14	5.90	4	23.60
13	1200	14	12.00	4	48.00
14	1200	14	12.00	4	48.00
15	1200	14	12.00	4	48.00
16	1200	14	12.00	3	36.00
17	455	14	5.00	1	5.00

18	545	14	5.90	1	5.90
19	1025	14	10.90	4	43.60
20	195	20	2.40	4	9.60
21	300	20	3.00	4	12.00
22	300	20	3.00	4	12.00
23	300	20	3.00	4	12.00
24	300	20	3.00	4	12.00
25	300	20	3.00	4	12.00
26	300	20	3.00	4	12.00
27	300	20	3.00	4	12.00
28	300	20	3.00	4	12.00
29	1000	20	10.00	2	20.00
30	555	20	6.00	2	12.00
31	255	20	3.00	2	6.00
32	400	20	4.00	4	16.00
33	300	20	3.00	4	12.00
34	175	20	2.40	4	9.60
35	45	8	1.50	688	1032.00
36	55	8	1.66	22	36.52
37	65	8	1.90	120	228.00

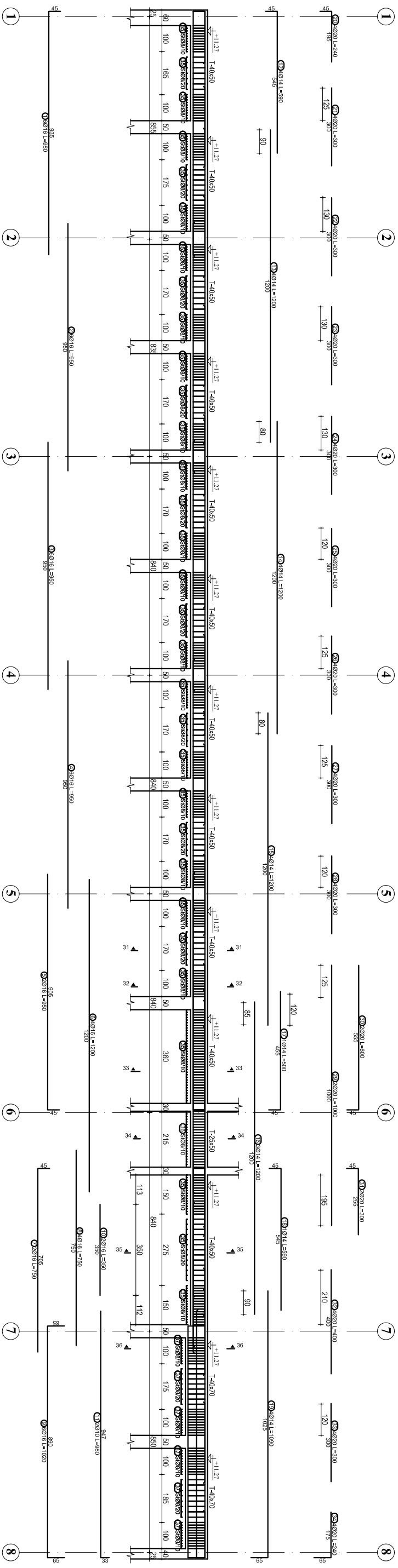
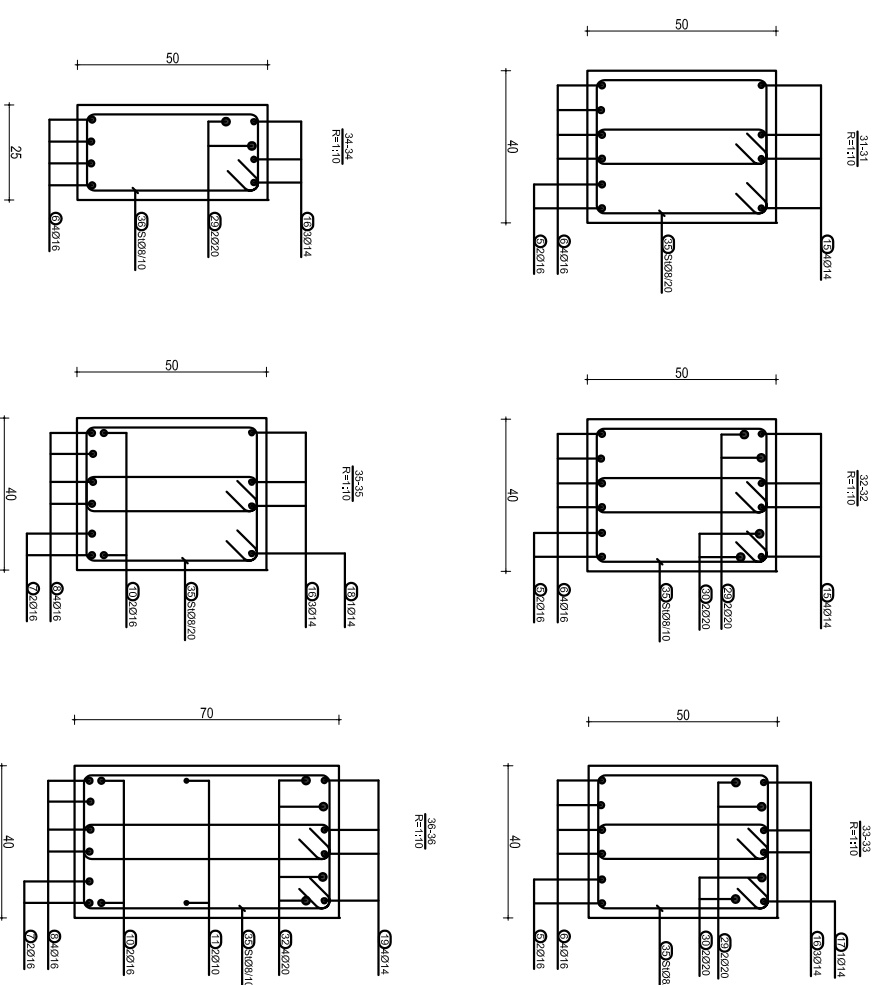

SHENIME TEKNIKE:
 BETONI: C30/37
 HEKURI: S500 OSE EKUIVALENT

OBJEKTI:	
EMERTIMI:	ARMIMI TRAREVE, KUOTA +11.27 m
KONSTRUKTOR:	DHIMITER PAPA
KONSTRUKTOR:	K.15102
KONSTRUKTOR:	Nr. Fieles
KONSTRUKTOR:	K-220
Dl.	

ARMIMI I TRAUT NE DHE NEN AKSIN E(7-8), KUOTA +11.27 m

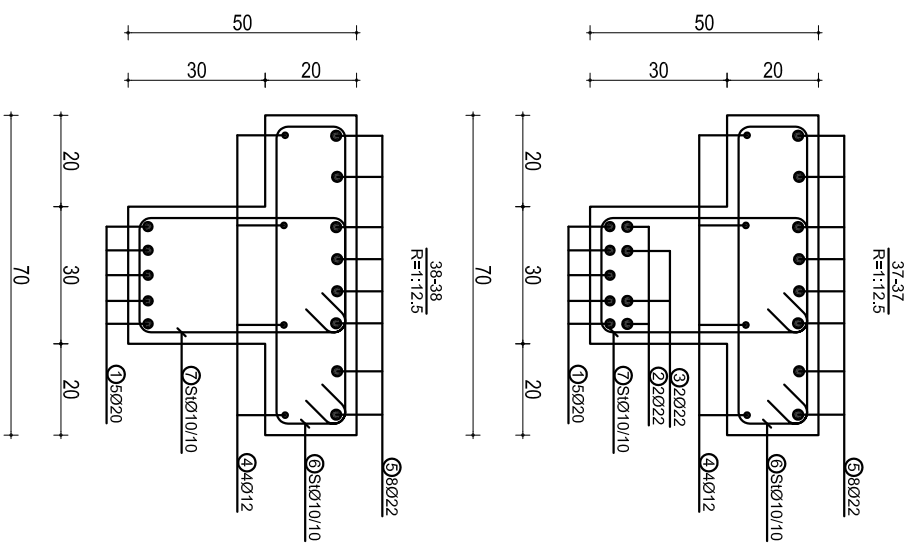
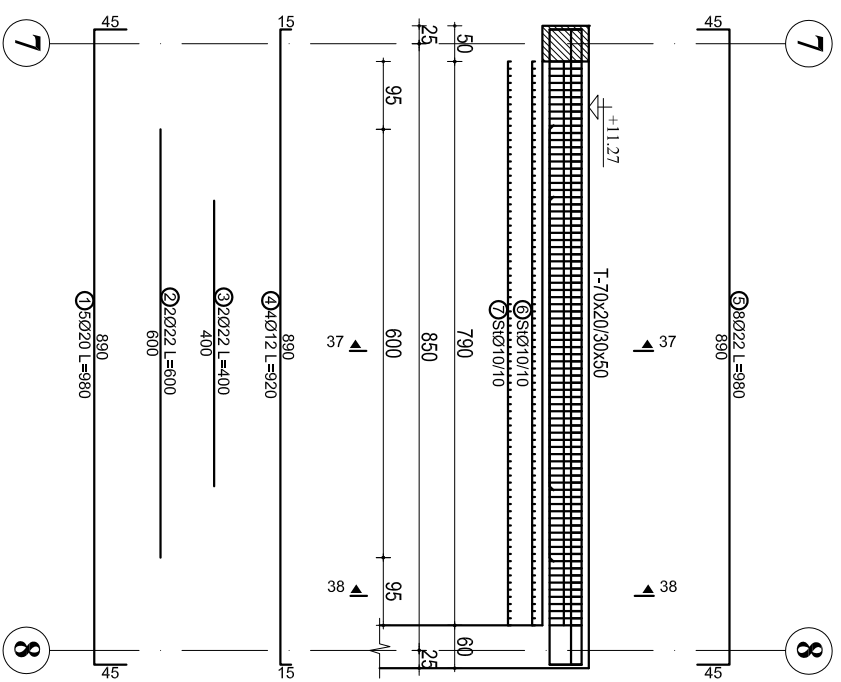

ARMIMI I BREZIT NEN AKSIN H(5-6), KUOTA +11.27 m

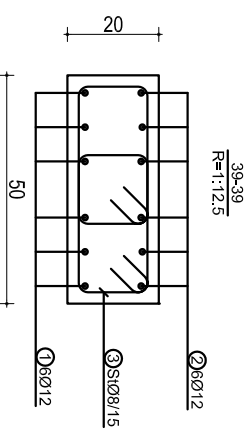
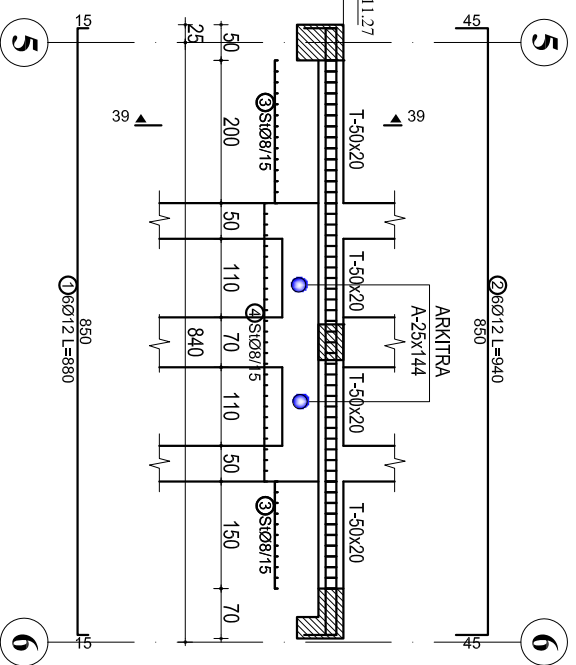

ARMIMI I TRAUT NEN AKSIN 7(H-I), KUOTA +11.27 m



TABELA E SPECIFIKIMIT TE ARMATURES

Nr.	FORMA DHE PERMASAT [cm]	Ø	l [m]	n [copel]	l(totale) [m]
Trau ne dhe nen aksin E(7-8), kuota +11.27 m (1 pcs.)					
1	45 890	20	9.80	5	49.00
2	600	22	6.00	2	12.00
3	400	22	4.00	2	8.00
4	15 890	12	9.20	4	36.80
5	45 890	22	9.80	8	78.40
6	15 65	10	1.76	80	140.80
7	25 45	10	1.56	80	124.80
Brezl nen aksin H(5-6), kuota +11.27 m (1 pcs.)					
1	15 850	12	8.80	6	52.80
2	45 850	12	9.40	6	56.40
3	30 30	8	1.06	50	53.00
4	15 45	8	1.05	27	28.35
Trau nen aksin 7(H-I) m, kuota +11.27 m (1 pcs.)					
1	15 620	12	6.50	7	45.50
2	35 620	12	6.90	7	48.30
3	25 220	14	4.90	7	34.30
4	40 40	8	1.26	70	88.20
5	25 40	8	1.46	26	37.96

SHENIME TEKNIKE:
BETONI: C30/37
HEKURI: S500 OSE EKUIVALENT

OBJEKTI:	
EMERTIMI:	ARMIMI TRAREVE, KUOTA +11.27 m
KONSTRUKTOR	DHIMITER PAPA
KONSTRUKTOR	
KONSTRUKTOR	
	Ni. Fliers
	K-221
	Dl.

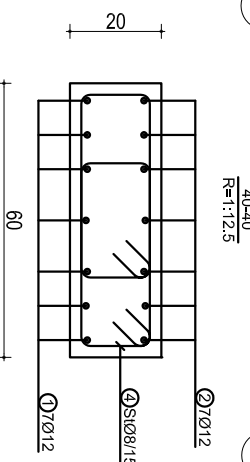
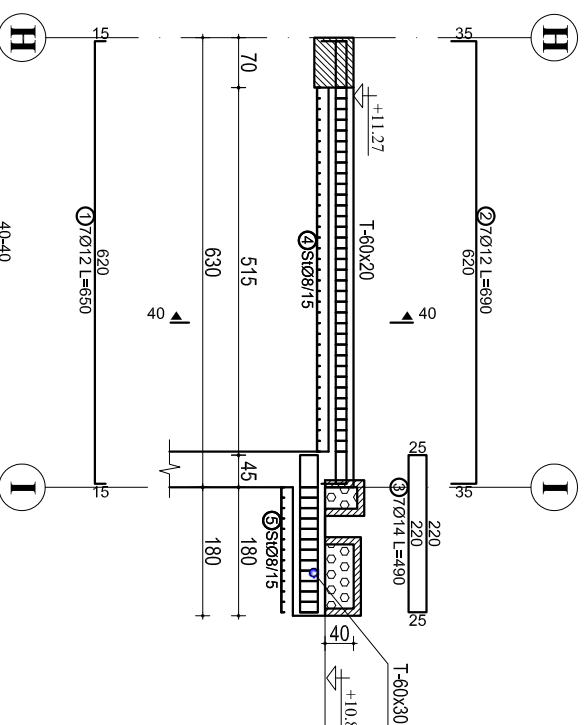
**ARMIMI I TRAUT NEN AKSIN F(1-2),
KUOTA +11.27 m**

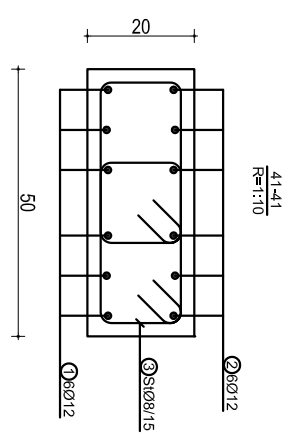
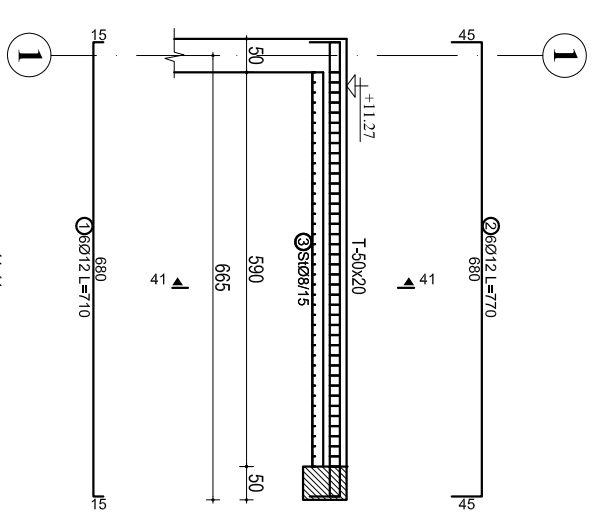

ARMIMI I TRAUT NE AKSIN G(1-3), KUOTA +11.27 m



TABELA E SPECIFIKIMIT TE ARMATURES

Nr.	FORMA DHE PERMASAT [cm]	Ø	l [m]	n [cope]	l(totale) [m]
Trau nen aksin F(1-2), kuota +11.27 m (1 pcs.)					
1	15 680 15	12	7.10	6	42.60
2	45 680 45	12	7.70	6	46.20
3	15 30 15 30	8	1.06	80	84.80

Trau ne aksin G(1-3), kuota +11.27 m (1 pcs.)					
1	35 680 35	14	7.50	7	52.50
2	15 1185 15	14	12.00	7	84.00
3	350	16	3.50	2	7.00
4	35 1165 35	16	12.00	4	48.00
5	655 45	16	7.00	4	28.00
6	35 665 35	16	7.00	4	28.00
7	45 1155 45	16	12.00	4	48.00
8	45 45 45	8	1.76	90	158.40
9	15 45 15 45	8	1.36	120	163.20

OBJEKTI:

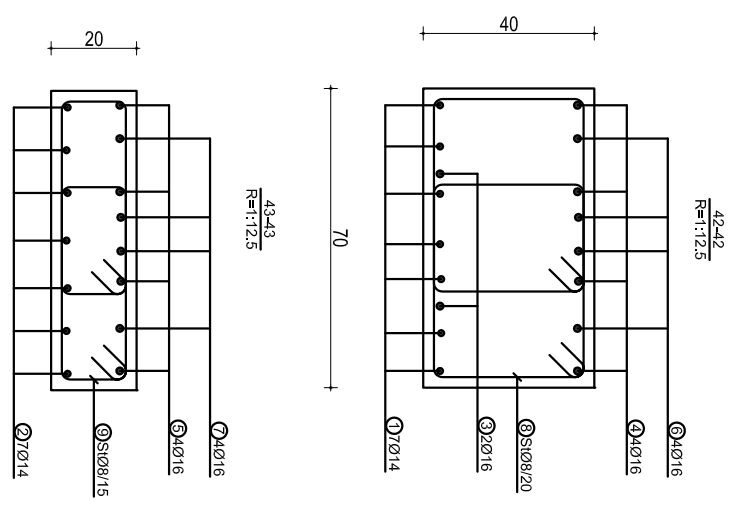
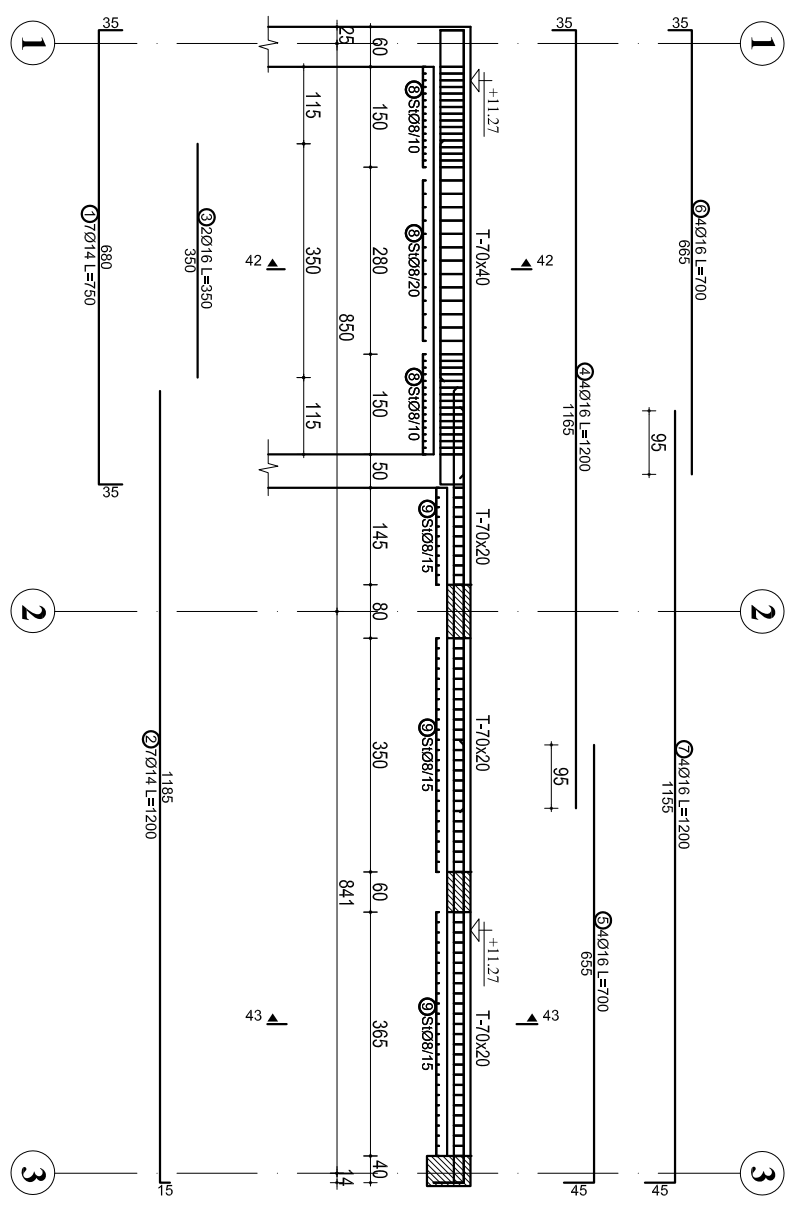
EMERTIRI: ARMIMI I TRAREVE, KUOTA +11.27 m

KONSTRUKTOR: **DHIMITER PAPA** K.15/10/2

SHENIME TEKNIKE:

BETONI: C30/37

HEKURI: S500 OSE EKUIVALENT

Nr. Fieles: **K-222**

Dl.

ARMIMI I TRAUT NE AKSIN 1, KUOTA +11.27 m



TABELA E SPECIFIKIMIT TE ARMATURES

Nr.	FORMA DHE PERMASAT [cm]	Ø	l [m]	n [coppel]	l (totale) [m]
Traut ne aksin 1, kuota +11.27 m (1 cope)					
1		16	8.50	6	51.00
2		16	8.00	6	48.00
3		16	12.00	6	72.00
4		16	9.80	6	58.80
5		16	9.50	6	57.00
6		20	4.00	2	8.00
7		20	4.00	2	8.00
8		20	3.50	2	7.00
9		20	3.50	2	7.00
10		20	3.00	2	6.00
11		14	12.00	2	24.00
12		14	12.00	2	24.00
13		14	10.00	2	20.00

14		14	12.00	2	24.00
15		14	6.00	2	12.00
16		14	12.00	2	24.00
17		14	12.00	2	24.00
18		14	10.70	2	21.40
19		14	6.00	2	12.00
20		20	3.50	4	14.00
21		20	5.00	4	20.00
22		20	10.80	4	43.20
23		20	3.00	4	12.00
24		20	3.00	4	12.00
25		20	3.00	4	12.00
26		20	6.50	4	26.00
27		8	1.70	194	329.80
28		8	1.50	430	645.00

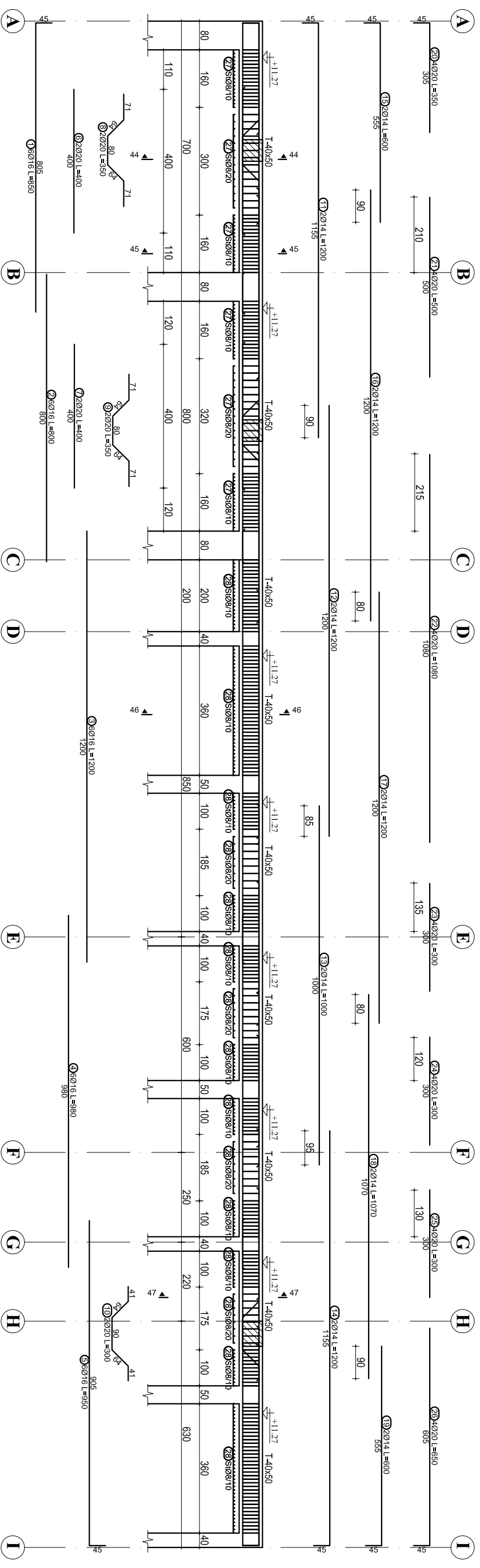
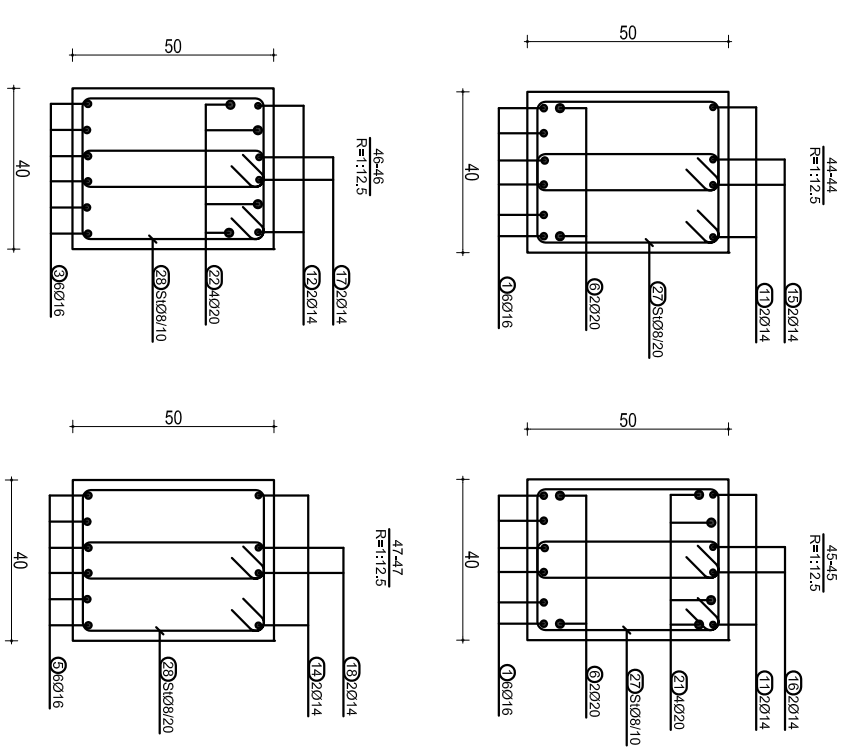

SHENIME TEKNIKE:
BETONI: C30/37
HEKURI: S500 OSE EKUIVALENT

OBJEKTI:	DHIMITER PAPA	
EMERTIMI:	ARMIMI I TRAVEE, KUOTA +11.27 m	K:15102
KONSTRUKTOR:	DHIMITER PAPA	Ni, Fielis
KONSTRUKTOR:		K-223
KONSTRUKTOR:		Dl.

ARMIMI I TRAUT MIDIS AKSEVE 2 DHE 3, KUOTA +11.27 m



TABELA E SPECIFIKIMIT TE ARMATURES

Nr.	FORMA DHE PERMASAT [cm]	Ø	l [m]	n [copel]	l(totale) [m]
1	15	14	12.00	7	84.00
2	700	14	7.00	7	49.00
3	15	14	12.00	7	84.00
4	500	14	5.00	2	10.00
5	240	14	2.40	2	4.80
6	240	14	2.40	2	4.80
7	300	14	3.00	2	6.00
8	15	14	12.00	2	24.00
9	1200	14	12.00	2	24.00

10	645	14	7.00	2	14.00
11	15	14	6.00	2	12.00
12	900	14	9.00	2	18.00
13	1200	14	12.00	2	24.00
14	55	14	4.50	2	9.00
15	585	14	6.00	4	24.00
16	500	14	5.00	4	20.00
17	400	14	4.00	4	16.00
18	400	14	4.00	4	16.00
19	245	14	3.00	4	12.00
20	40	8	1.26	424	534.24

SHENIME TEKNIKE:
 BETONI: C30/37
 HEKURI: S500 OSE EKUIVALENT

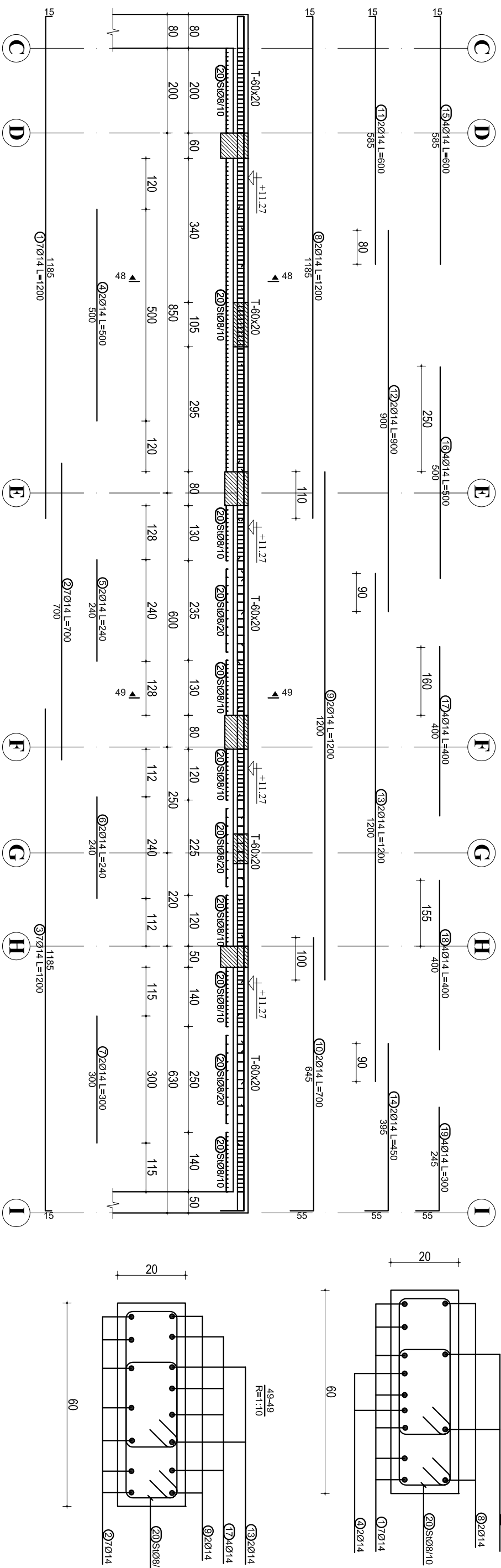
OBJEKTI:	
EMERTIMI:	ARMIMI I TRAEVE, KUOTA +11.27 m
KONSTRUKTOR:	DHIMITER PAPA
KONSTRUKTOR:	K.15102
KONSTRUKTOR:	Nf. Fielis
KONSTRUKTOR:	K-224
Dl.	

ARMIMI I TRAUT NE AKSIN 4(F-I) DHE 5(F-I), KUOTA +11.27 m

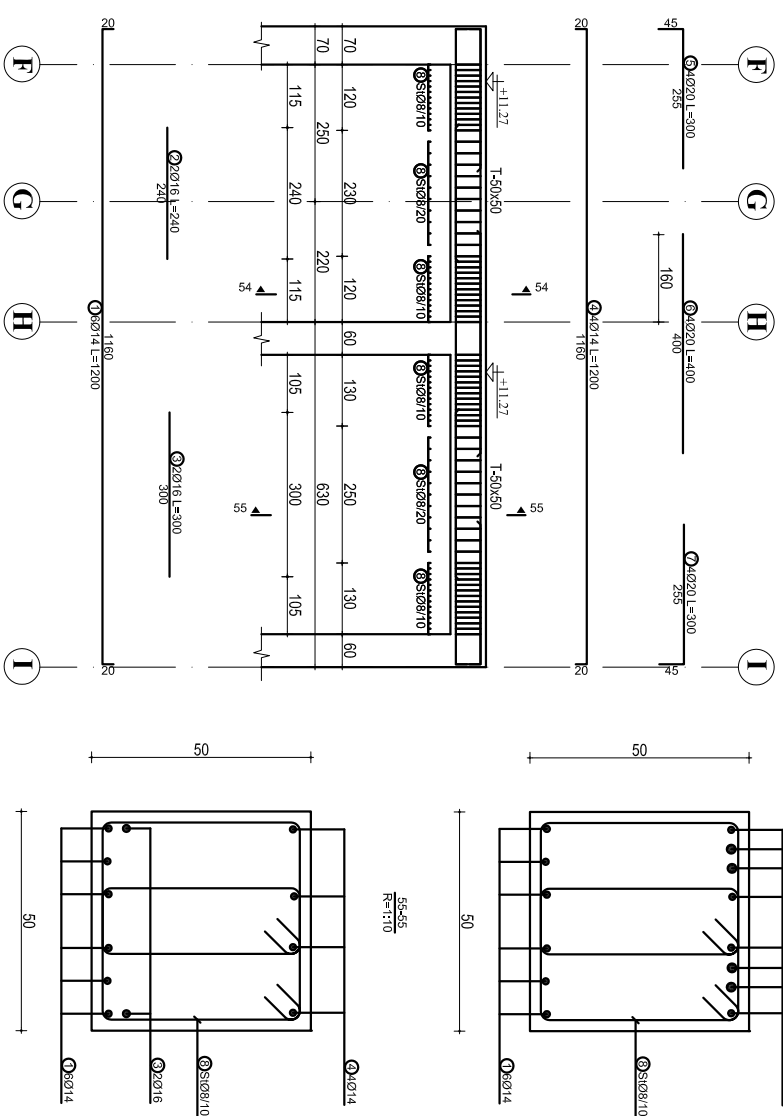

ARMIMI I TRAUT NE DHE NEN AKSIN 6(F-I), KUOTA +11.27 m



TABELA E SPECIFIKIMIT TE ARMATURES

Nr.	FORMA DHE PERMASAT [cm]	Ø	l [m]	n [cope]	l(totale) [m]
1		14	12.00	6	72.00
2		16	2.40	2	4.80
3		16	3.00	2	6.00
4		14	12.00	4	48.00
5		20	3.00	4	12.00
6		20	4.00	4	16.00
7		20	3.00	4	12.00
8		8	1.66	150	249.00
Trau ne dhe nen aksin 6(F-I), kuota +11.27 m (1 cope)					
1		14	12.00	5	60.00
2		16	2.40	2	4.80
3		10	11.70	4	46.80
4		14	12.00	4	48.00
5		16	2.40	4	9.60
6		16	4.00	4	16.00
7		16	3.00	4	12.00
8		8	1.76	66	116.16
9		8	1.56	66	102.96

OBJEKTI:			
EMERTIMI: ARMIMI I TRAVEVE, KUOTA +11.27 m			
KONSTRUKTOR	DHIMITER PAPA	K.15102	
KONSTRUKTOR			Ni. Fliers
KONSTRUKTOR			K-226
			Dl.

BETONI: C30/37
HEKURPI: S500 OSE EKUIVALENT

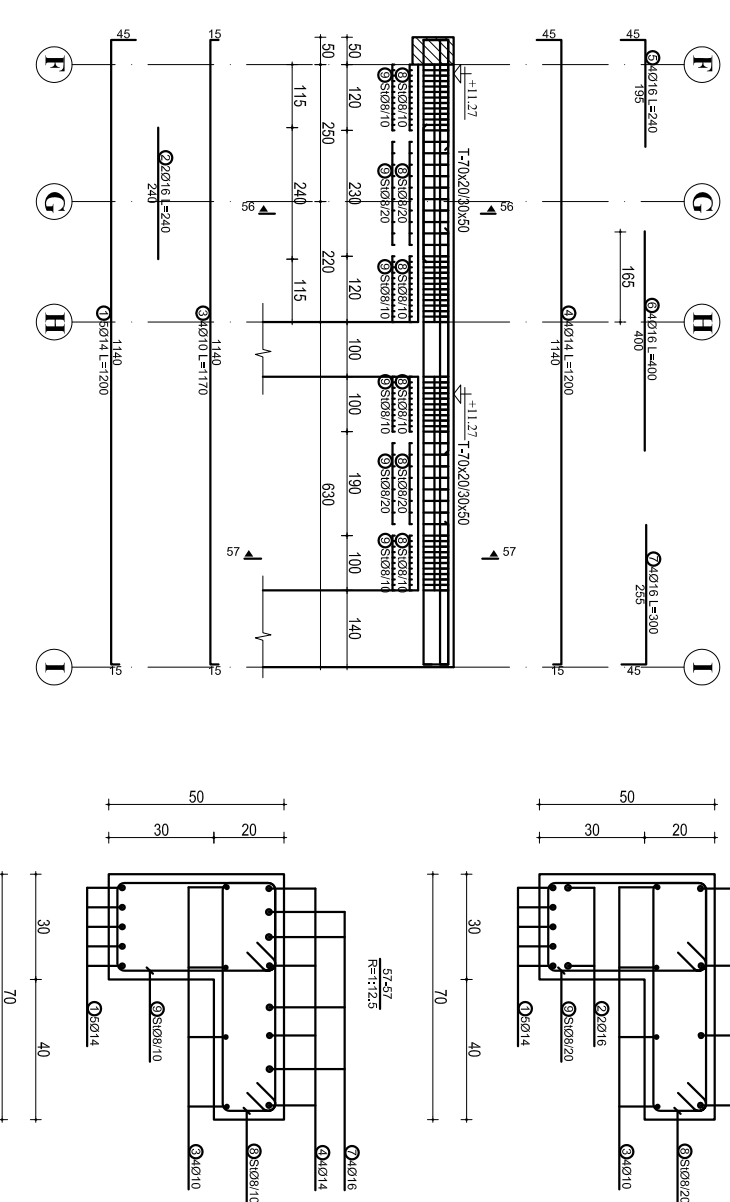