



BASHKIA LIBOHOVE

OBJEKTI:

RIPARIMIN DHE ASFALTIM I RRUGËS AUTOMOBILISTIKE FUSHA E ÇAJUPIT – TOPOVË, PJESË E UNAZËS SË ZAGORISË L= 8971 ML.

PROFIL TERTHOR TE RRUGES

06/2024
SHK:1:1000

HARTOI: SEKTORI SHERBIMIT URBAN
ARK. NELSON SEJDO

SEKSIONI NR. : 1
 KUOTA PROJEKTIT : I225.992
 PROGRESIVA : 0.000

SEKSIONI NR. : 3
 KUOTA PROJEKTIT : I226.910
 PROGRESIVA : 50.000

SHKALLA 1:100

SHKALLA 1:100

KUOTA REF. I222.306

KUOTA REF. I223.992

| | | | | | | | |
|---------------------------|-----|--------------------|---------|---------|---------|---------|---------|
| KUOTA E TOKES | | I225.29 | I225.34 | I225.41 | I225.49 | I225.75 | |
| DIST. PJESORE E TOKES | 5.7 | 0.8 | 0.9 | 1.3 | 1.5 | | 6.5 |
| KUOTA E PROJEKTIT | | I225.32 I225.43 | | | I225.49 | | I225.43 |
| DIST. PJESORE E PROJEKTIT | | | 2.5 | | 2.5 | | |

| | | | | | | | | | | | | | |
|---------------------------|--|---------|---------|---------|--------------------|---------|---------|---------|---------|---------|---------|---------|---------|
| KUOTA E TOKES | | I226.25 | I226.36 | I226.40 | I226.59 | I226.62 | I226.61 | I226.61 | I226.62 | I226.87 | I227.35 | I227.27 | I227.69 |
| DIST. PJESORE E TOKES | | 0.6 | 1.4 | 1.7 | 1.0 | 0.9 | 0.5 | 0.5 | 2.1 | 1.0 | 0.6 | 1.9 | |
| KUOTA E PROJEKTIT | | | | | I226.56 I226.35 | | | I226.41 | | I226.35 | | | |
| DIST. PJESORE E PROJEKTIT | | | | | 0.2 | 2.5 | | 2.5 | | | | | |

SEKSIONI NR. : 2
 KUOTA PROJEKTIT : I226.529
 PROGRESIVA : 25.000

SEKSIONI NR. : 4
 KUOTA PROJEKTIT : I226.932
 PROGRESIVA : 75.000

SHKALLA 1:100

SHKALLA 1:100

KUOTA REF. I223.171

KUOTA REF. I223.096

| | | | | | | | | |
|---------------------------|--|---------|--------------------|--------------------|---------|---------|-------------------------------|---------|
| KUOTA E TOKES | | I225.55 | I226.08 | I226.20 I226.21 | I226.27 | I226.33 | I226.36 I226.36 I226.37 | I226.56 |
| DIST. PJESORE E TOKES | | 4.8 | 1.0 | 0.8 | 0.7 | 1.8 | 2.7 | 1.5 |
| KUOTA E PROJEKTIT | | | I226.01 I225.97 | | I226.03 | | I225.97 | |
| DIST. PJESORE E PROJEKTIT | | | 2.5 | | 2.5 | | | |

| | | | | | | | | |
|---------------------------|--|---------|--------------------|---------|---------|---------|-----|---------|
| KUOTA E TOKES | | I226.00 | I226.07 | I226.13 | I226.17 | I226.24 | | I226.88 |
| DIST. PJESORE E TOKES | | 0.9 | 0.9 | 1.1 | 0.7 | | 6.1 | |
| KUOTA E PROJEKTIT | | | I226.06 I226.37 | | | | | |
| DIST. PJESORE E PROJEKTIT | | | 0.3 | 2.5 | | | | |



BASHKIA LIBOHOVE

OBJEKTI:
 RIPARIMIN DHE ASFALTIM I RRUGËS
 AUTOMOBILIS TIKE FUSHA E ÇAJUPIT – TOPOVË,
 PJESE E UNAZËS SË ZAGORISË L= 8971 ML.

Data:
 06/2024

EMERTIMI I FLETES:

PROFIL TERTHOR

SHK
 1:1000

HARTOI: SEKTORI SHERBIMIT URBAN
 ARK. NELSON SEJDO

Nr. fleta
 01

SEKSIONI NR. : 5
 KUOTA PROJEKTIT : 1226.948
 PROGRESIVA : 100.000

SEKSIONI NR. : 7
 KUOTA PROJEKTIT : 1226.981
 PROGRESIVA : 150.000

SHKALLA 1:100

SHKALLA 1:100

KUOTA REF. 1223.558

KUOTA REF. 1222.734

| | | | | | | | | | | |
|---------------------------|-----|--------------------|--------------------|--------------------|---------|---------|---------|---------|---------|-----|
| KUOTA E TOKES | | 1225.95 1225.95 | | 1226.09 1226.09 | 1226.14 | 1226.27 | 1226.39 | 1226.66 | 1227.10 | |
| DIST. PJESORE E TOKES | 2.3 | 0.2 | 2.7 | 0.2 | 0.7 | 1.4 | 1.3 | 1.1 | 2.5 | 2.5 |
| KUOTA E PROJEKTIT | | | 1226.06 1226.39 | | | 1226.45 | | 1226.39 | | |
| DIST. PJESORE E PROJEKTIT | | | 0.3 | | 2.5 | | 2.5 | | | |

| | | | | | | | | | | |
|---------------------------|-----|--|--|--|--------------------|---------|---------|--------------------|---------|-----|
| KUOTA E TOKES | | | 1225.97 1225.95 1225.95 1225.95 | | 1225.86 1225.86 | 1225.86 | 1225.88 | | 1226.04 | |
| DIST. PJESORE E TOKES | 6.8 | | 0.2 | | 1.4 | 1.2 | 0.3 | | 3.2 | 1.8 |
| KUOTA E PROJEKTIT | | | 1225.81 1226.42 | | 1226.48 | | | 1226.42 1225.95 | | |
| DIST. PJESORE E PROJEKTIT | | | 0.6 | | 2.5 | | 2.5 | 0.5 | | |

SEKSIONI NR. : 6
 KUOTA PROJEKTIT : 1226.965
 PROGRESIVA : 125.000

SEKSIONI NR. : 8
 KUOTA PROJEKTIT : 1226.998
 PROGRESIVA : 175.000

SHKALLA 1:100

SHKALLA 1:100

KUOTA REF. 1222.677

KUOTA REF. 1222.730

| | | | | | | | | | | |
|---------------------------|--|---------|--|--|---------|---------|---------|--------------------|---------|-----|
| KUOTA E TOKES | | 1225.68 | 1225.82 1225.80 1225.81 1225.82 | | 1225.87 | 1225.98 | 1226.05 | 1226.17 | 1226.34 | |
| DIST. PJESORE E TOKES | | 1.4 | 0.3 0.3 | | 2.3 | 1.2 | 0.7 | 1.9 | 3.1 | 1.9 |
| KUOTA E PROJEKTIT | | | 1225.83 1226.40 | | | 1226.46 | | 1226.40 1226.17 | | |
| DIST. PJESORE E PROJEKTIT | | | 0.6 | | 2.5 | | 2.5 | 0.2 | | |

| | | | | | | | | | | | | | |
|---------------------------|--|---------|--|--------------------|--|---------|---------|---------|--------------------|---------|--------------------|---------|--|
| KUOTA E TOKES | | 1225.29 | | 1225.74 | | 1225.88 | 1225.90 | 1225.85 | 1225.87 1225.88 | 1225.88 | 1225.80 | 1225.90 | |
| DIST. PJESORE E TOKES | | 1.6 | | 1.7 | | 1.2 | 0.7 | 0.5 | 0.3 | 0.5 | 1.4 | 2.1 | |
| KUOTA E PROJEKTIT | | | | 1225.82 1226.43 | | | | 1226.50 | | | 1226.43 1226.85 | | |
| DIST. PJESORE E PROJEKTIT | | | | 0.6 | | 2.5 | | | | | | | |



BASHKIA LIBOHOVE

OBJEKTI:
 RIPARIMIN DHE ASFALTIM I RRUGËS
 AUTOMOBILIS TIKE FUSHA E ÇAJUPIT – TOPOVË,
 PJESË E UNAZËS SË ZAGORISË L= 8971 ML.

Data:
 06/2024

EMERTIMI I FLETES:
 PROFIL TERTHOR

SHK
 1:1000

HARTOI: SEKTORI SHERBIMIT URBAN
 ARK. NELSON SEJDO

Nr. fleta
 02

SEKSIONI NR. : 9
 KUOTA PROJEKTIT : I227.014
 PROGRESIVA : 200.000

SEKSIONI NR. : II
 KUOTA PROJEKTIT : I227.047
 PROGRESIVA : 250.000

SHKALLA 1:100

SHKALLA 1:100

KUOTA REF. I222.719

KUOTA REF. I222.800

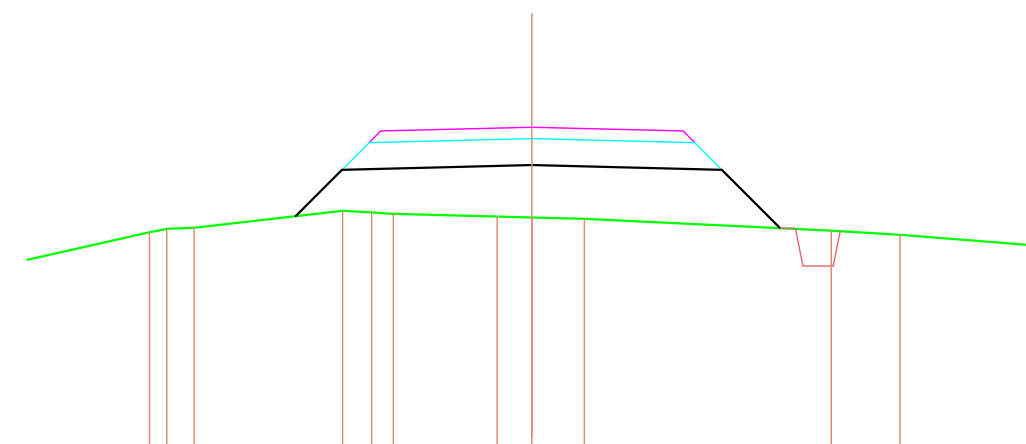
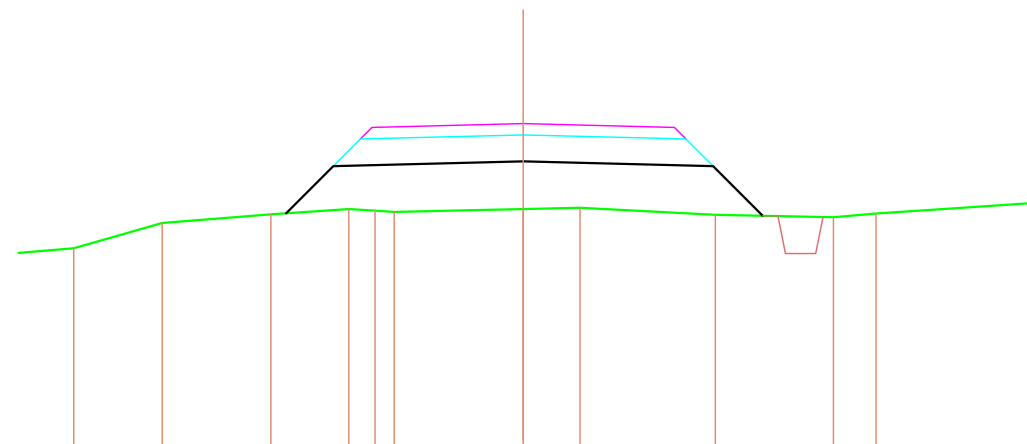

| | | | | | | | | | | | |
|---------------------------|---------|---------|---------|---------|---------|---------|---------|---------|---------|---------|---------|
| KUOTA E TOKES | I225.36 | I225.70 | I225.81 | I225.88 | I225.86 | I225.85 | I225.88 | I225.90 | I225.81 | I225.78 | I225.82 |
| DIST. PJESORE E TOKES | 1.2 | 1.4 | 1.0 | 0.3 | 0.3 | 1.7 | 0.8 | 1.8 | 1.6 | 0.6 | |
| KUOTA E PROJEKTIT | | | I225.83 | I226.45 | | | I226.51 | | I226.45 | I225.79 | |
| DIST. PJESORE E PROJEKTIT | | | 0.6 | 2.5 | | | 2.5 | | 0.7 | | |

| | | | | | | | | | | | | |
|---------------------------|---------|---------|---------|---------|---------|---------|---------|---------|---------|---------|---------|-----|
| KUOTA E TOKES | I225.66 | I225.70 | I225.72 | I225.94 | I225.92 | I225.90 | I225.86 | I225.85 | I225.84 | I225.68 | I225.62 | |
| DIST. PJESORE E TOKES | 0.2 | 0.4 | 2.0 | 0.4 | 0.3 | 1.4 | 0.5 | 0.7 | | 3.3 | 0.9 | 2.7 |
| KUOTA E PROJEKTIT | | | | I225.87 | I226.48 | | I226.55 | | | I226.48 | I225.71 | |
| DIST. PJESORE E PROJEKTIT | | | | 0.6 | 2.5 | | 2.5 | | | 0.8 | | |

SEKSIONI NR. : 10
 KUOTA PROJEKTIT : I227.031
 PROGRESIVA : 225.000

SEKSIONI NR. : 12
 KUOTA PROJEKTIT : I227.068
 PROGRESIVA : 275.000

SHKALLA 1:100

SHKALLA 1:100

KUOTA REF. I222.849

KUOTA REF. I222.813

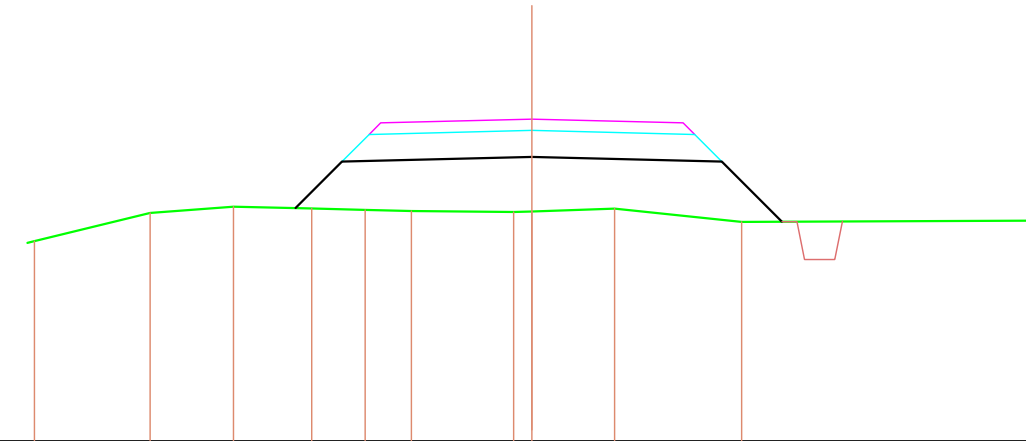
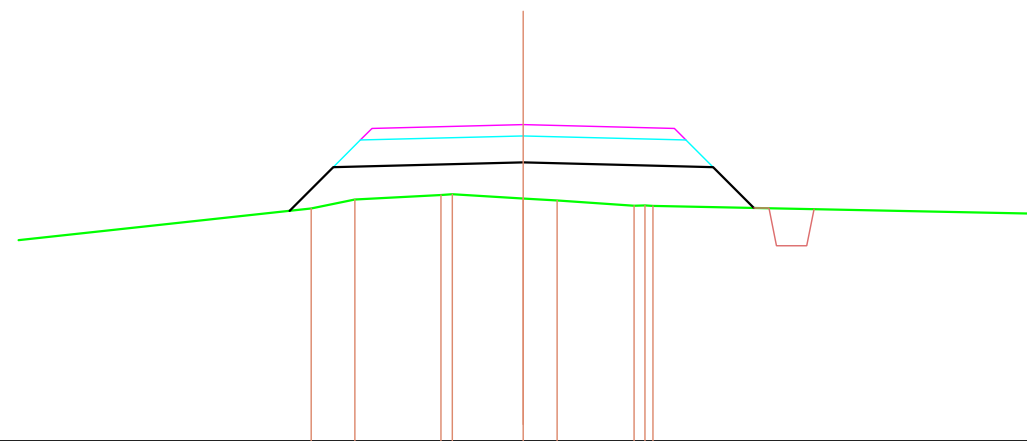

| | | | | | | | | | | |
|---------------------------|-----|---------|---------|---------|---------|---------|---------|---------|---------|-----|
| KUOTA E TOKES | | I225.92 | I226.04 | I226.10 | I226.11 | I226.05 | I226.03 | I225.96 | I225.96 | |
| DIST. PJESORE E TOKES | 5.6 | 0.6 | 1.1 | 0.9 | 0.4 | 1.0 | | | | 6.2 |
| KUOTA E PROJEKTIT | | I225.89 | I226.47 | | | I226.53 | | I226.47 | I225.93 | |
| DIST. PJESORE E PROJEKTIT | | 0.6 | 2.5 | | | 2.5 | | 0.5 | | |

| | | | | | | | | | | |
|---------------------------|---------|---------|---------|---------|---------|---------|---------|---------|---------|---------|
| KUOTA E TOKES | I225.45 | I225.83 | I225.91 | I225.89 | I225.87 | I225.85 | I225.84 | I225.85 | I225.88 | I225.71 |
| DIST. PJESORE E TOKES | 1.5 | 1.1 | 1.0 | 0.7 | 0.6 | 1.4 | 0.2 | 1.1 | 1.7 | 8.0 |
| KUOTA E PROJEKTIT | | | | I225.89 | I226.50 | | I226.57 | | I226.50 | I225.71 |
| DIST. PJESORE E PROJEKTIT | | | | 0.6 | 2.5 | | | | | |



BASHKIA LIBOHOVE

OBJEKTI:
 RIPARIMIN DHE ASFALTIM I RRUGËS
 AUTOMOBILIS TIKE FUSHA E ÇAJUPIT – TOPOVË,
 PJESË E UNAZËS SË ZAGORISË L= 8971 ML.

Data:
 06/2024

EMERTIMI I FLETES:
 PROFIL TERTHOR

SHK
 1:1000

HARTOI: SEKTORI SHERBIMIT URBAN
 ARK. NELSON SEJDO

Nr. fleta
 03

SEKSIONI NR. : 13
 KUOTA PROJEKTIT : I227.177
 PROGRESIVA : 300.000

SEKSIONI NR. : 15
 KUOTA PROJEKTIT : I227.772
 PROGRESIVA : 350.000

SHKALLA 1:100

SHKALLA 1:100

KUOTA REF. I223.410

KUOTA REF. I224.358

| | | | | | | | | | | |
|---------------------------|---------|---------|---------|---------|---------|---------|---------|---------|---------|-----|
| KUOTA E TOKES | I225.96 | I226.01 | I226.13 | I226.12 | I226.15 | I226.17 | I226.17 | I226.22 | I226.04 | |
| DIST. PJESORE E TOKES | 2.7 | 1.5 | 1.5 | 1.4 | 0.4 | 1.0 | 0.9 | 0.3 | 1.6 | 3.2 |
| KUOTA E PROJEKTIT | | I226.03 | I226.61 | | I226.68 | | | I226.61 | I226.15 | |
| DIST. PJESORE E PROJEKTIT | | 0.6 | 2.5 | | 2.5 | | | 0.5 | | |

| | | | | | | | | |
|---------------------------|---------|---------|---------|---------|---------|---------|---------|---------|
| KUOTA E TOKES | I227.12 | I227.14 | I227.17 | I227.16 | I227.20 | I227.22 | I227.14 | |
| DIST. PJESORE E TOKES | 1.1 | 0.8 | 0.8 | 0.2 | 0.9 | | 6.6 | |
| KUOTA E PROJEKTIT | I227.15 | I227.21 | | I227.27 | | | I227.21 | I227.17 |
| DIST. PJESORE E PROJEKTIT | | 2.5 | | 2.5 | | | | |

SEKSIONI NR. : 14
 KUOTA PROJEKTIT : I227.412
 PROGRESIVA : 325.000

SEKSIONI NR. : 16
 KUOTA PROJEKTIT : I228.248
 PROGRESIVA : 375.000

SHKALLA 1:100

SHKALLA 1:100

KUOTA REF. I223.869

KUOTA REF. I224.781

| | | | | | | | | | |
|---------------------------|---------|---------|---------|---------|---------|---------|---------|---------|--|
| KUOTA E TOKES | I226.55 | I226.55 | I226.56 | I226.57 | I226.58 | I226.58 | I226.70 | I226.70 | |
| DIST. PJESORE E TOKES | 0.7 | 0.5 | 1.8 | 0.5 | 0.2 | 0.8 | | 9.0 | |
| KUOTA E PROJEKTIT | I226.55 | I226.85 | | I226.91 | | | I226.85 | I226.73 | |
| DIST. PJESORE E PROJEKTIT | 0.3 | 2.5 | | 2.5 | | | | | |

| | | | | | | | | | |
|---------------------------|---------|---------|---------|---------|---------|---------|---------|---------|---------|
| KUOTA E TOKES | I227.54 | I227.60 | I227.65 | I227.71 | I227.74 | I227.76 | I227.78 | I227.81 | I227.72 |
| DIST. PJESORE E TOKES | 0.8 | 2.1 | 0.7 | 2.2 | 0.2 | | | | |
| KUOTA E PROJEKTIT | | | | I227.71 | I227.69 | | | | |
| DIST. PJESORE E PROJEKTIT | | | | 2.5 | | | | | |



BASHKIA LIBOHOVE

OBJEKTI:
 RIPARIMIN DHE ASFALTIM I RRUGËS
 AUTOMOBILIS TIKE FUSHA E ÇAJUPIT – TOPOVË,
 PJESË E UNAZËS SË ZAGORISË L= 8971 ML.

EMERTIMI I FLETES:
 PROFIL TERTHOR

HARTOI: SEKTORI SHERBIMIT URBAN
 ARK. NELSON SEJDO

Data:
 06/2024

SHK
 1:1000

Nr. fleta
 04

SEKSIONI NR. : 17
 KUOTA PROJEKTIT : I228.712
 PROGRESIVA : 400.000

SEKSIONI NR. : 19
 KUOTA PROJEKTIT : I229.183
 PROGRESIVA : 450.000

SHKALLA 1:100

SHKALLA 1:100

KUOTA REF. I225.121

KUOTA REF. I225.461

| | | | | | | | | | |
|---------------------------|-----|--------------------|---------|-------------------------------|-------------------------------|--------------------|---------|---------|--|
| KUOTA E TOKES | | I228.11 | I228.16 | I228.23 I228.25 I228.26 | I228.32 I228.33 I228.34 | I228.40 I228.38 | I228.48 | I228.51 | |
| DIST. PJESORE E TOKES | 4.2 | 1.0 | 0.9 | 0.2 0.9 | 0.2 1.6 | 1.6 | 1.3 | 3.8 | |
| KUOTA E PROJEKTIT | | I228.14 I228.15 | | I228.21 | | I228.15 | | | |
| DIST. PJESORE E PROJEKTIT | | | 2.5 | | 2.5 | | | | |

| | | | | | | |
|---------------------------|-----|--------------------|--------------------|--------------------|---------|---------|
| KUOTA E TOKES | | I228.28 | I228.57 I228.60 | I228.62 I228.62 | I228.65 | I228.80 |
| DIST. PJESORE E TOKES | 5.2 | 1.8 | 0.5 0.9 | 1.1 | 3.5 | |
| KUOTA E PROJEKTIT | | I228.38 I228.62 | | I228.68 | | I228.62 |
| DIST. PJESORE E PROJEKTIT | | 0.2 | 2.5 | 2.5 | | |

SEKSIONI NR. : 18
 KUOTA PROJEKTIT : I229.025
 PROGRESIVA : 425.000

SEKSIONI NR. : 20
 KUOTA PROJEKTIT : I229.184
 PROGRESIVA : 475.000

SHKALLA 1:100

SHKALLA 1:100

KUOTA REF. I225.318

KUOTA REF. I225.484

| | | | | | | |
|---------------------------|-----|--------------------|---------|--|--------------------|------------|
| KUOTA E TOKES | | I227.90 | I228.27 | I228.44 I228.46 I228.47 I228.49 | I228.53 I228.55 | I228.45 |
| DIST. PJESORE E TOKES | 4.8 | | 1.2 | 0.4 0.3 0.3 | 1.2 | 0.5 0.7 |
| KUOTA E PROJEKTIT | | I228.18 I228.46 | | I228.53 | | I228.46 |
| DIST. PJESORE E PROJEKTIT | | 0.3 | 2.5 | | 2.5 | |

| | | | | | | | | |
|---------------------------|-----|---------|---------|--------------------|-------------------------------|-------------------------------|---------|---------|
| KUOTA E TOKES | | I228.38 | I228.49 | I228.59 | I228.56 I228.57 I228.57 | I228.65 I228.65 I228.64 | I228.77 | I228.79 |
| DIST. PJESORE E TOKES | 1.2 | 1.4 | 1.5 | 1.9 | 0.2 0.6 | | | |
| KUOTA E PROJEKTIT | | | | I228.58 I228.62 | | | | |
| DIST. PJESORE E PROJEKTIT | | | | 2.5 | | | | |

| | |
|--|---|
| BASHKIA LIBOHOVE | |
| | OBJEKTI: RIPARIMIN DHE ASFALTIM I RRUGËS AUTOMOBILIS TIKE FUSHA E ÇAJUPIT – TOPOVË, PJESË E UNAZËS SË ZAGORISË L= 8971 ML. |
| Data: | 06/2024 |
| EMERTIMI I FLETES: PROFIL TERTHOR | |
| SHK 1:1000 | |
| HARTOI: SEKTORI SHERBIMIT URBAN ARK. NELSON SEJDO | |
| Nr. fleta 05 | |

SEKSIONI NR. : 21
 KUOTA PROJEKTIT : I229.029
 PROGRESIVA : 500.000

SEKSIONI NR. : 23
 KUOTA PROJEKTIT : I228.250
 PROGRESIVA : 550.000

SHKALLA 1:100

SHKALLA 1:100

KUOTA REF. I225.147

KUOTA REF. I224.830

| | | | | | | | | | | |
|---------------------------|---------|-----|---------|---------|---------|---------|---------|---------|---------|---------|
| KUOTA E TOKES | I227.95 | | | I228.36 | I228.35 | I228.36 | I228.43 | I228.41 | I228.43 | I228.40 |
| DIST. PJESORE E TOKES | | 6.2 | | 0.4 | 0.7 | | 1.1 | | 2.3 | |
| KUOTA E PROJEKTIT | | | I228.21 | I228.47 | | I228.63 | | I228.47 | I228.42 | |
| DIST. PJESORE E PROJEKTIT | | | 0.3 | | 2.5 | | 2.5 | | | |

| | | | | | | | | | |
|---------------------------|-----|---------|---------|---------|---------|---------|---------|---------|-----|
| KUOTA E TOKES | | I227.65 | I227.65 | I227.68 | I227.71 | I227.79 | I227.89 | I227.93 | |
| DIST. PJESORE E TOKES | 5.7 | | 0.8 | 1.4 | 0.3 | 0.9 | 1.1 | 1.3 | 3.8 |
| KUOTA E PROJEKTIT | | I227.65 | I227.69 | | I227.75 | | | I227.69 | |
| DIST. PJESORE E PROJEKTIT | | | 2.5 | | 2.5 | | | | |

SEKSIONI NR. : 22
 KUOTA PROJEKTIT : I228.718
 PROGRESIVA : 525.000

SEKSIONI NR. : 24
 KUOTA PROJEKTIT : I227.700
 PROGRESIVA : 575.000

SHKALLA 1:100

SHKALLA 1:100

KUOTA REF. I225.019

KUOTA REF. I224.382

| | | | | | | | | | | | | | |
|---------------------------|---------|---------|---------|---------|---------|---------|---------|---------|---------|---------|---------|---------|---------|
| KUOTA E TOKES | I227.75 | I227.82 | I227.88 | I227.92 | I228.01 | I228.05 | I228.04 | I228.05 | I228.09 | I228.18 | I228.21 | I228.20 | I228.31 |
| DIST. PJESORE E TOKES | 0.7 | 1.0 | 2.2 | 1.5 | 0.4 | 0.6 | | 1.6 | 1.0 | 1.2 | 1.1 | 1.2 | |
| KUOTA E PROJEKTIT | | | | I227.92 | I228.15 | | I228.22 | | I228.15 | | | | |
| DIST. PJESORE E PROJEKTIT | | | | 0.2 | | 2.5 | | 2.5 | | | | | |

| | | | | | | | | | | |
|---------------------------|---------|---------|---------|---------|---------|---------|---------|---------|---------|---------|
| KUOTA E TOKES | I227.03 | | I227.36 | I227.37 | I227.38 | I227.42 | I227.44 | I227.49 | I227.50 | I227.64 |
| DIST. PJESORE E TOKES | | 5.0 | 0.4 | 1.0 | 0.3 | 0.8 | 0.9 | 1.5 | | 6.9 |
| KUOTA E PROJEKTIT | | I227.30 | I227.14 | | | | | | | |
| DIST. PJESORE E PROJEKTIT | | | 0.2 | | 2.5 | | | | | |

BASHKIA LIBOHOVE

OBJEKTI:
 RIPARIMIN DHE ASFALTIM I RRUGËS
 AUTOMOBILIS TIKE FUSHA E ÇAJUPIT – TOPOVË,
 PJESË E UNAZËS SË ZAGORISË L= 8971 ML.

Data: 06/2024

EMERTIMI I FLETES:
 PROFIL TERTHOR

SHK 1:1000

HARTOI: SEKTORI SHERBIMIT URBAN
 ARK. NELSON SEJDO

Nr. fleta
 06

SEKSIONI NR. : 25
 KUOTA PROJEKTIT : I227.150
 PROGRESIVA : 600.000

SEKSIONI NR. : 27
 KUOTA PROJEKTIT : I226.051
 PROGRESIVA : 650.000

SHKALLA 1:100

SHKALLA 1:100

KUOTA REF. I223.834

KUOTA REF. I222.654

| | | | | | | | | | |
|---------------------------|---------|---------|---------|---------|---------|---------|---------|---------|---------|
| KUOTA E TOKES | I226.75 | I226.75 | I226.72 | I226.77 | I226.80 | I226.81 | I226.82 | I226.90 | I226.86 |
| DIST. PJESORE E TOKES | 1.3 | 0.7 | 0.5 | 1.0 | 0.5 | 0.6 | 1.4 | 4.5 | |
| KUOTA E PROJEKTIT | I226.74 | I226.59 | I226.65 | I226.59 | | | | | |
| DIST. PJESORE E PROJEKTIT | 2.5 | 2.5 | | | | | | | |

| | | | | | | | | |
|---------------------------|---------|---------|---------|---------|---------|---------|---------|---------|
| KUOTA E TOKES | I225.58 | I225.58 | I225.57 | I225.57 | I225.65 | I225.66 | I225.72 | I225.73 |
| DIST. PJESORE E TOKES | 4.6 | 0.3 | 1.8 | 0.2 | 1.4 | 2.5 | 5.0 | |
| KUOTA E PROJEKTIT | I225.57 | I225.49 | I225.55 | I225.49 | | | | |
| DIST. PJESORE E PROJEKTIT | 2.5 | 2.5 | | | | | | |

SEKSIONI NR. : 26
 KUOTA PROJEKTIT : I226.601
 PROGRESIVA : 625.000

SEKSIONI NR. : 28
 KUOTA PROJEKTIT : I225.501
 PROGRESIVA : 675.000

SHKALLA 1:100

SHKALLA 1:100

KUOTA REF. I223.243

KUOTA REF. I222.129

| | | | | | | | | | | | |
|---------------------------|---------|---------|---------|---------|---------|---------|---------|---------|---------|---------|---------|
| KUOTA E TOKES | I226.28 | I226.24 | I226.24 | I226.28 | I226.29 | I226.30 | I226.30 | I226.48 | I226.52 | I226.45 | I226.45 |
| DIST. PJESORE E TOKES | 2.8 | 0.3 | 2.8 | 0.2 | 0.3 | 1.4 | 0.6 | 3.4 | 0.6 | | |
| KUOTA E PROJEKTIT | I226.25 | I226.04 | I226.10 | I226.04 | | | | | | | |
| DIST. PJESORE E PROJEKTIT | 0.2 | 2.5 | 2.5 | | | | | | | | |

| | | | | | | | | |
|---------------------------|---------|---------|---------|---------|---------|---------|---------|---------|
| KUOTA E TOKES | I225.08 | I225.10 | I224.90 | I224.83 | I224.92 | I225.16 | I225.18 | I225.19 |
| DIST. PJESORE E TOKES | 3.8 | 0.9 | 1.5 | 1.3 | | | | |
| KUOTA E PROJEKTIT | I225.06 | I224.94 | | | | | | |
| DIST. PJESORE E PROJEKTIT | 2.5 | | | | | | | |



BASHKIA LIBOHOVE
 OBJEKTI:
 RIPARIMIN DHE ASFALTIM I RRUGËS
 AUTOMOBILIS TIKE FUSHA E ÇAJUPIT – TOPOVË,
 PJESË E UNAZËS SË ZAGORISË L= 8971 ML.

Data:
06/2024

EMERTIMI I FLETES:
 PROFIL TERTHOR

SHK
1:1000

HARTOI: SEKTORI SHERBIMIT URBAN
 ARK. NELSON SEJDO

Nr. fleta
07

SEKSIONI NR. : 29
 KUOTA PROJEKTIT : I224.95I
 PROGRESIVA : 700.000

SEKSIONI NR. : 31
 KUOTA PROJEKTIT : I223.914
 PROGRESIVA : 750.000

SHKALLA 1:100

SHKALLA 1:100

KUOTA REF. I221.470

KUOTA REF. I220.663

| | | | | | | | | | | |
|---------------------------|-----|--------------------|--------------------|--------------------|--|--|--|---------|--|---------|
| KUOTA E TOKES | | I224.39 I224.39 | | I224.26 I224.26 | | I224.33 I224.33 I224.35 I224.34 I224.32 I224.35 | | I224.43 | | I224.75 |
| DIST. PJESORE E TOKES | 4.0 | | 2.3 | 1.3 | | 2.9 | | 2.7 | | |
| KUOTA E PROJEKTIT | | | I224.31 I224.39 | | | I224.45 | | I224.39 | | |
| DIST. PJESORE E PROJEKTIT | | | | 2.5 | | 2.5 | | | | |

| | | | | | | | | | | | | |
|---------------------------|--|---------|--|-------------------------------|--|---------|--|--------------------|--|-------------------------------|--|---------|
| KUOTA E TOKES | | I223.38 | | I223.42 I223.41 I223.40 | | I223.39 | | I223.35 I223.33 | | I223.42 I223.42 I223.47 | | I223.47 |
| DIST. PJESORE E TOKES | | 2.9 | | 0.2 0.6 | | 1.0 | | 0.3 1.8 | | 3.6 | | |
| KUOTA E PROJEKTIT | | | | I223.41 I223.35 | | | | I223.41 | | I223.35 | | |
| DIST. PJESORE E PROJEKTIT | | | | | | 2.5 | | 2.5 | | | | |

SEKSIONI NR. : 30
 KUOTA PROJEKTIT : I224.40I
 PROGRESIVA : 725.000

SEKSIONI NR. : 32
 KUOTA PROJEKTIT : I223.55I
 PROGRESIVA : 775.000

SHKALLA 1:100

SHKALLA 1:100

KUOTA REF. I221.026

KUOTA REF. I220.157

| | | | | | | | | | | | | | | |
|---------------------------|--|---------|--|---------|--|--------------------|--|---------|--|--|--|---------|--|---------|
| KUOTA E TOKES | | I223.94 | | I223.96 | | I223.90 | | I223.83 | | I223.81 I223.81 I223.84 I223.88 | | I224.20 | | I224.10 |
| DIST. PJESORE E TOKES | | 1.0 | | 1.5 | | 1.2 | | 1.6 | | 0.2 0.5 0.2 | | 1.1 | | 1.5 |
| KUOTA E PROJEKTIT | | | | | | I223.88 I223.84 | | | | I223.90 | | | | I223.84 |
| DIST. PJESORE E PROJEKTIT | | | | | | | | 2.5 | | 2.5 | | | | |

| | | | | | | | | | | | | | | | | |
|---------------------------|--|---------|--|---------|--|--------------------|--|---------|--|---------|--|---------|--|---------|--|---------|
| KUOTA E TOKES | | I222.86 | | I222.95 | | I222.97 | | I222.91 | | I223.00 | | I223.07 | | I223.05 | | I223.08 |
| DIST. PJESORE E TOKES | | 2.4 | | 1.0 | | 1.4 | | 0.9 | | | | | | | | |
| KUOTA E PROJEKTIT | | | | | | I222.96 I222.99 | | | | | | | | | | |
| DIST. PJESORE E PROJEKTIT | | | | | | | | 2.5 | | | | | | | | |



BASHKIA LIBOHOVE
 OBJEKTI:
 RIPARIMIN DHE ASFALTIM I RRUGËS
 AUTOMOBILIS TIKE FUSHA E ÇAJUPIT – TOPOVË,
 PJESË E UNAZËS SË ZAGORISË L= 8971 ML.

Data:
06/2024

EMERTIMI I FLETES:
 PROFIL TERTHOR

SHK
1:1000

HARTOI: SEKTORI SHERBIMIT URBAN
 ARK. NELSON SEJDO

Nr. fleta
08

SEKSIONI NR. : 33
 KUOTA PROJEKTIT : 1223.251
 PROGRESIVA : 800.000

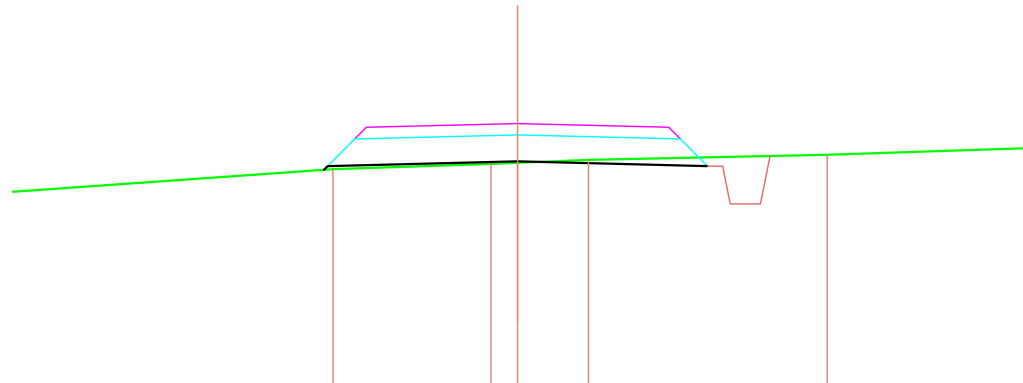

SHKALLA 1:100

KUOTA REF. 1219.767

| | | | | | | |
|---------------------------|---------|--------------------|---------|---------|---------|---------|
| KUOTA E TOKES | 1222.34 | 1222.65 | 1222.72 | 1222.73 | 1222.77 | 1222.84 |
| DIST. PJESORE E TOKES | 4.3 | 2.1 | 0.4 | 0.9 | 3.2 | 2.9 |
| KUOTA E PROJEKTIT | | 1222.64 1222.69 | 1222.75 | 1222.69 | | |
| DIST. PJESORE E PROJEKTIT | | 2.5 | 2.5 | | | |

SEKSIONI NR. : 35
 KUOTA PROJEKTIT : 1222.650
 PROGRESIVA : 850.000

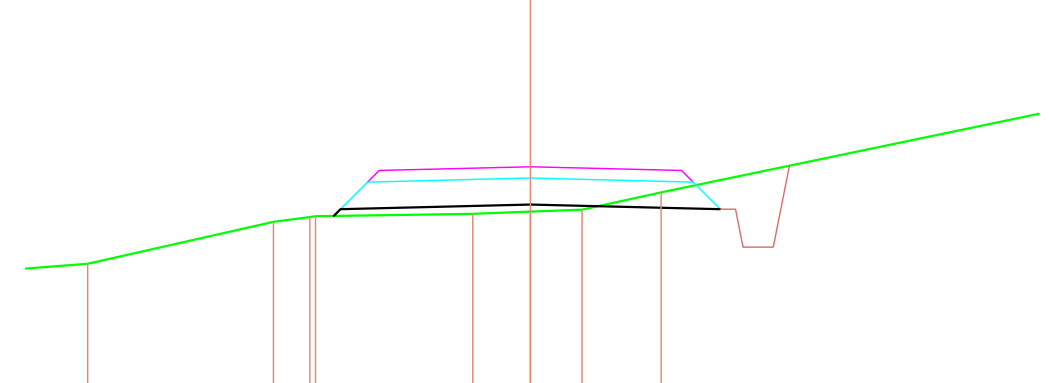

SHKALLA 1:100

KUOTA REF. 1219.738

| | | | | | | | | |
|---------------------------|---------|--------------------|---------|---------|---------|---------|---------|---------|
| KUOTA E TOKES | 1221.37 | 1221.92 | 1221.98 | 1222.00 | 1222.03 | 1222.06 | 1222.08 | 1222.31 |
| DIST. PJESORE E TOKES | 2.5 | 0.5 | 2.1 | 0.8 | 0.7 | 1.0 | | 7.8 |
| KUOTA E PROJEKTIT | | 1222.00 1222.09 | | 1222.15 | | 1222.09 | | |
| DIST. PJESORE E PROJEKTIT | | 2.5 | 2.5 | | | | | |

SEKSIONI NR. : 34
 KUOTA PROJEKTIT : 1222.951
 PROGRESIVA : 825.000

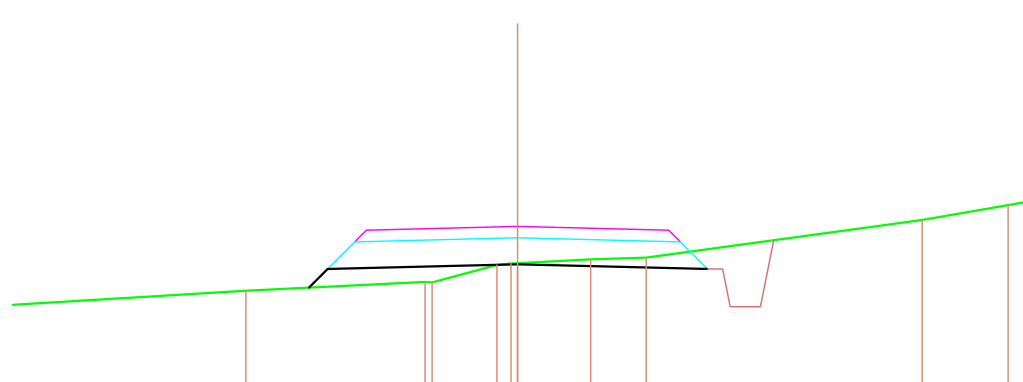

SHKALLA 1:100

KUOTA REF. 1219.908

| | | | | | | | | | | |
|---------------------------|---------|--------------------|---------|---------|---------|---------|---------|---------|---------|---------|
| KUOTA E TOKES | 1222.10 | 1222.22 | 1222.21 | 1222.44 | 1222.46 | 1222.46 | 1222.52 | 1222.54 | 1223.04 | 1223.23 |
| DIST. PJESORE E TOKES | 2.4 | 0.9 | 0.2 | 1.0 | 0.7 | 3.7 | 1.1 | | | |
| KUOTA E PROJEKTIT | | 1222.14 1222.39 | 1222.45 | 1222.39 | | | | | | |
| DIST. PJESORE E PROJEKTIT | | 0.2 | 2.5 | 2.5 | | | | | | |

SEKSIONI NR. : 36
 KUOTA PROJEKTIT : 1222.350
 PROGRESIVA : 875.000

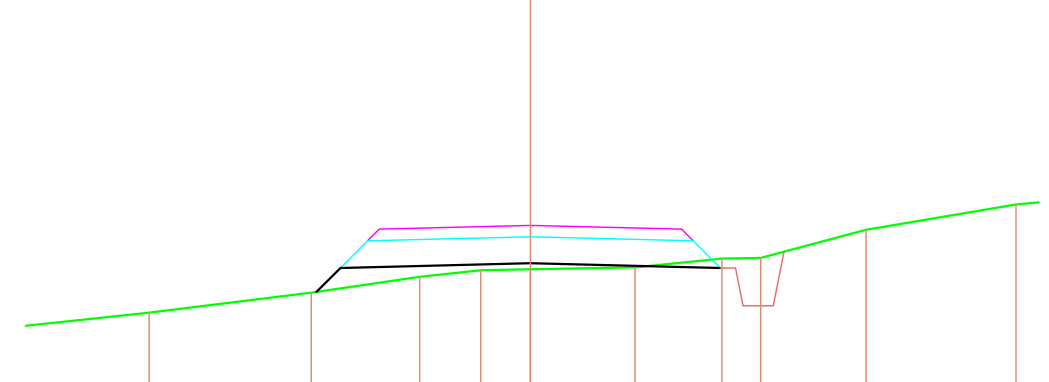

SHKALLA 1:100

KUOTA REF. 1219.293

| | | | | | | | | | | |
|---------------------------|---------|--------------------|---------|---------|---------|---------|---------|---------|---------|---------|
| KUOTA E TOKES | 1221.20 | 1221.46 | 1221.67 | 1221.76 | 1221.77 | 1221.79 | 1221.91 | 1221.92 | 1222.29 | 1222.63 |
| DIST. PJESORE E TOKES | 2.1 | 1.4 | 0.8 | 0.7 | 1.4 | 1.2 | 0.5 | 1.4 | 2.0 | |
| KUOTA E PROJEKTIT | | 1221.47 1221.79 | | 2.5 | | | | | | |
| DIST. PJESORE E PROJEKTIT | | 0.3 | 2.5 | | | | | | | |



BASHKIA LIBOHOVE
 OBJEKTI:
 RIPARIMIN DHE ASFALTIM I RRUGËS
 AUTOMOBILIS TIKE FUSHA E ÇAJUPIT – TOPOVË,
 PJESË E UNAZËS SË ZAGORISË L= 8971 ML.

EMERTIMI I FLETES:
 PROFIL TERTHOR

HARTOI: SEKTORI SHERBIMIT URBAN
 ARK. NELSON SEJDO

Data:
 06/2024
 SHK
 1:1000
 Nr. fleta
 09

SEKSIONI NR. : 37
 KUOTA PROJEKTIT : I222.126
 PROGRESIVA : 900.000

SEKSIONI NR. : 39
 KUOTA PROJEKTIT : I222.33
 PROGRESIVA : 950.000

SHKALLA 1:100

SHKALLA 1:100

KUOTA REF. I218.758

KUOTA REF. I219.844

| | | | | | | | | | |
|---------------------------|---------|---------|--------------------|---------|---------|---------|---------|---------|---------|
| KUOTA E TOKES | I221.09 | I221.50 | I221.52 | I221.54 | I221.53 | I221.53 | I221.61 | I221.66 | I222.17 |
| DIST. PJESORE E TOKES | 1.1 | 1.7 | 1.6 | 1.1 | 0.4 | 1.6 | 1.5 | 1.1 | 3.4 |
| KUOTA E PROJEKTIT | | | I221.52 I221.56 | | I221.63 | | I221.56 | | |
| DIST. PJESORE E PROJEKTIT | | | 2.5 | | 2.5 | | | | |

| | | | | | | | | | | | | | |
|---------------------------|---------|---------|---------|--------------------|---------|---------|---------|--------------------|---------|---------|---------|---------|---------|
| KUOTA E TOKES | I221.02 | I221.16 | I221.39 | I221.40 | I221.45 | I221.45 | I221.46 | I221.46 | I221.47 | I221.46 | I221.43 | I221.47 | I221.46 |
| DIST. PJESORE E TOKES | 1.1 | 0.9 | 1.2 | 2.0 | 0.6 | 0.4 | 0.4 | 0.9 | 0.7 | 0.8 | 0.3 | 2.9 | 0.5 |
| KUOTA E PROJEKTIT | | | | I221.41 I221.57 | | I221.63 | | I221.57 I221.46 | | | | | |
| DIST. PJESORE E PROJEKTIT | | | | 2.5 | | 2.5 | | | | | | | |

SEKSIONI NR. : 38
 KUOTA PROJEKTIT : I222.058
 PROGRESIVA : 925.000

SEKSIONI NR. : 40
 KUOTA PROJEKTIT : I222.236
 PROGRESIVA : 975.000

SHKALLA 1:100

SHKALLA 1:100

KUOTA REF. I218.872

KUOTA REF. I219.727

| | | | | | | | | | |
|---------------------------|---------|--------------------|---------|---------|---------|---------|---------|---------|--------------------|
| KUOTA E TOKES | I221.12 | I221.17 | I221.44 | I221.43 | I221.43 | I221.44 | I221.44 | I221.44 | I222.29 I222.35 |
| DIST. PJESORE E TOKES | 2.2 | 2.1 | 1.1 | 1.0 | 0.5 | 0.4 | 2.0 | 3.0 | |
| KUOTA E PROJEKTIT | | I221.19 I221.50 | | | I221.56 | | I221.50 | | |
| DIST. PJESORE E PROJEKTIT | | 0.3 | 2.5 | | 2.5 | | | | |

| | | | | | | | | | | |
|---------------------------|---------|---------|--------------------|---------|---------|---------|---------|---------|---------|---------|
| KUOTA E TOKES | I220.47 | I220.64 | I221.52 | I221.52 | I221.54 | I221.55 | I221.55 | I221.54 | I222.14 | I223.10 |
| DIST. PJESORE E TOKES | 1.4 | 2.6 | 1.7 | 0.8 | 1.2 | 1.7 | 2.9 | 1.4 | | |
| KUOTA E PROJEKTIT | | | I221.52 I221.67 | | | | | | | |
| DIST. PJESORE E PROJEKTIT | | | 2.5 | | | | | | | |



BASHKIA LIBOHOVE

OBJEKTI:
 RIPARIMIN DHE ASFALTIM I RRUGËS
 AUTOMOBILIS TIKE FUSHA E ÇAJUPIT – TOPOVË,
 PJESË E UNAZËS SË ZAGORISË L= 8971 ML.

Data:

06/2024

EMERTIMI I FLETES:

PROFIL TERTHOR

SHK
 1:1000

HARTOI: SEKTORI SHERBIMIT URBAN
 ARK. NELSON SEJDO

Nr. fleta

10

SEKSIONI NR. : 41
 KUOTA PROJEKTIT : I222.339
 PROGRESIVA : I000.000

SEKSIONI NR. : 43
 KUOTA PROJEKTIT : I222.544
 PROGRESIVA : I050.000

SHKALLA 1:100

SHKALLA 1:100

KUOTA REF. I219.698

KUOTA REF. I219.846

| | | | | | | | | | | | | | | | |
|---------------------------|-----|---------|---------|---------|---------|---------|---------|-----|---------|---------|---------|---------|---------|--|---------|
| KUOTA E TOKES | | I221.50 | I221.61 | I221.72 | | I221.77 | I221.77 | | I221.71 | I221.72 | I221.72 | I221.71 | I221.70 | | I222.73 |
| DIST. PJESORE E TOKES | 4.1 | 0.9 | 0.3 | 2.8 | 0.3 | 2.9 | | 0.2 | 0.2 | 0.4 | | | 2.2 | | |
| KUOTA E PROJEKTIT | | | | I221.73 | I221.78 | | I221.84 | | I221.78 | I221.72 | | | | | |
| DIST. PJESORE E PROJEKTIT | | | | 2.5 | | 2.5 | | | | | | | | | |

| | | | | | | | | | | | | | | |
|---------------------------|--|---------|---------|---------|---------|---------|---------|---------|---------|---------|---------|---------|--|---------|
| KUOTA E TOKES | | I221.64 | I221.81 | I221.81 | I222.06 | I222.06 | I222.02 | | I221.96 | I222.05 | I222.11 | I222.17 | | I223.16 |
| DIST. PJESORE E TOKES | | 0.8 | 0.5 | 0.8 | 0.6 | 0.5 | 1.2 | 1.2 | 0.3 | 0.4 | | 2.0 | | 4.3 |
| KUOTA E PROJEKTIT | | | | | | | I222.01 | I221.98 | | | I222.04 | | | I221.98 |
| DIST. PJESORE E PROJEKTIT | | | | | | | 2.5 | | | 2.5 | | | | |

SEKSIONI NR. : 42
 KUOTA PROJEKTIT : I222.441
 PROGRESIVA : I025.000

SEKSIONI NR. : 44
 KUOTA PROJEKTIT : I222.647
 PROGRESIVA : I075.000

SHKALLA 1:100

SHKALLA 1:100

KUOTA REF. I220.092

KUOTA REF. I219.886

| | | | | | | | | | | |
|---------------------------|-----|---------|---------|---------|---------|---------|---------|---------|--|---------|
| KUOTA E TOKES | | I221.76 | I222.20 | I222.20 | I222.18 | I222.15 | I222.10 | I222.20 | | I223.15 |
| DIST. PJESORE E TOKES | 3.7 | 1.3 | 1.5 | 0.5 | 0.6 | 1.4 | 0.6 | 2.1 | | 2.5 |
| KUOTA E PROJEKTIT | | I222.00 | I221.88 | | I221.94 | | I221.88 | | | |
| DIST. PJESORE E PROJEKTIT | | | 2.5 | | 2.5 | | | | | |

| | | | | | | | | | |
|---------------------------|--|---------|---------|---------|---------|---------|---------|--|---------|
| KUOTA E TOKES | | I222.00 | I222.02 | I222.00 | I222.13 | I222.35 | I222.39 | | I222.50 |
| DIST. PJESORE E TOKES | | 1.7 | 1.3 | 1.3 | 0.9 | 0.7 | 2.1 | | 5.0 |
| KUOTA E PROJEKTIT | | | | | I222.04 | I222.08 | | | |
| DIST. PJESORE E PROJEKTIT | | | | | 2.5 | | | | |



BASHKIA LIBOHOVE
 OBJEKTI:
 RIPARIMIN DHE ASFALTIM I RRUGËS
 AUTOMOBILIS TIKE FUSHA E ÇAJUPIT – TOPOVË,
 PJESË E UNAZËS SË ZAGORISË L= 8971 ML.

EMERTIMI I FLETES:
 PROFIL TERTHOR

HARTOI: SEKTORI SHERBIMIT URBAN
 ARK. NELSON SEJDO

Data:
 06/2024
 SHK
 1:1000
 Nr. fleta
 11

SEKSIONI NR. : 45
 KUOTA PROJEKTIT : I222.803
 PROGRESIVA : I100.000

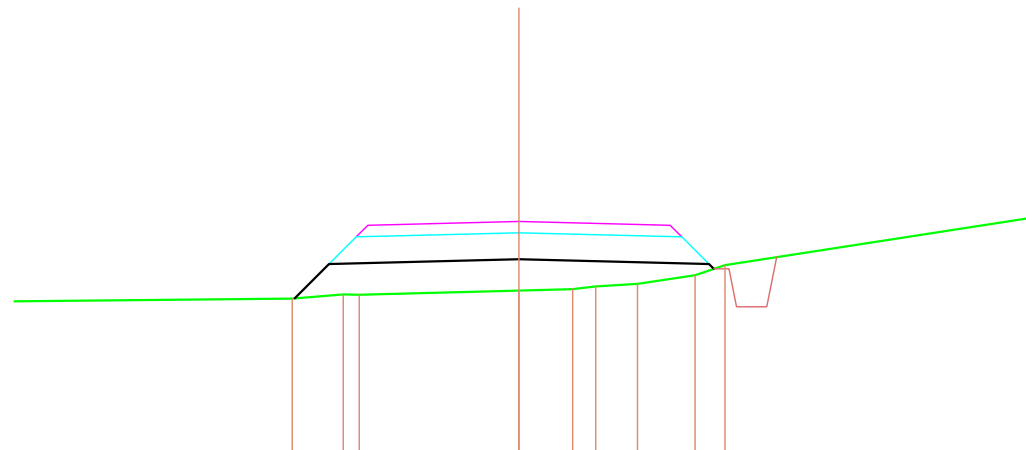

SHKALLA 1:100

KUOTA REF. I219.704

| | | | | | | | | | |
|---------------------------|-----|---------|--------------------|-----|---------|--------------------|---------|--------------------|--|
| KUOTA E TOKES | | I221.78 | I221.84 I221.85 | | I221.89 | I221.91 I221.94 | I221.98 | I222.09 I222.23 | |
| DIST. PJESORE E TOKES | 4.3 | 0.7 | 0.2 | 2.1 | 0.7 | 0.3 0.6 | 0.8 | 0.4 | |
| KUOTA E PROJEKTIT | | I221.79 | I222.24 | | I222.30 | | | I222.24 I222.18 | |
| DIST. PJESORE E PROJEKTIT | | 0.5 | 2.5 | | 2.5 | | | | |

SEKSIONI NR. : 47
 KUOTA PROJEKTIT : I223.813
 PROGRESIVA : I150.000

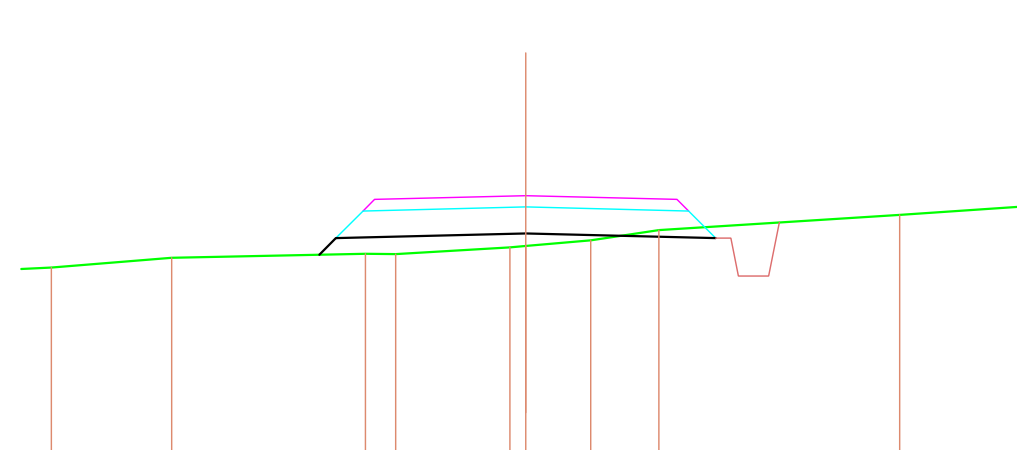

SHKALLA 1:100

KUOTA REF. I220.371

| | | | | | | | | | |
|---------------------------|--|---------|---------|--------------------|--------------------|------------|---------|---------|-----|
| KUOTA E TOKES | | I222.86 | I222.99 | I223.04 I223.04 | I223.13 I223.15 | I223.22 | I223.36 | I223.56 | |
| DIST. PJESORE E TOKES | | 1.6 | 2.6 | 0.4 | 1.5 | 0.2 0.9 | 0.9 | 3.2 | 2.7 |
| KUOTA E PROJEKTIT | | | | I223.03 I223.25 | | I223.31 | | I223.25 | |
| DIST. PJESORE E PROJEKTIT | | | | 0.2 | 2.5 | 2.5 | | | |

SEKSIONI NR. : 46
 KUOTA PROJEKTIT : I223.196
 PROGRESIVA : I125.000

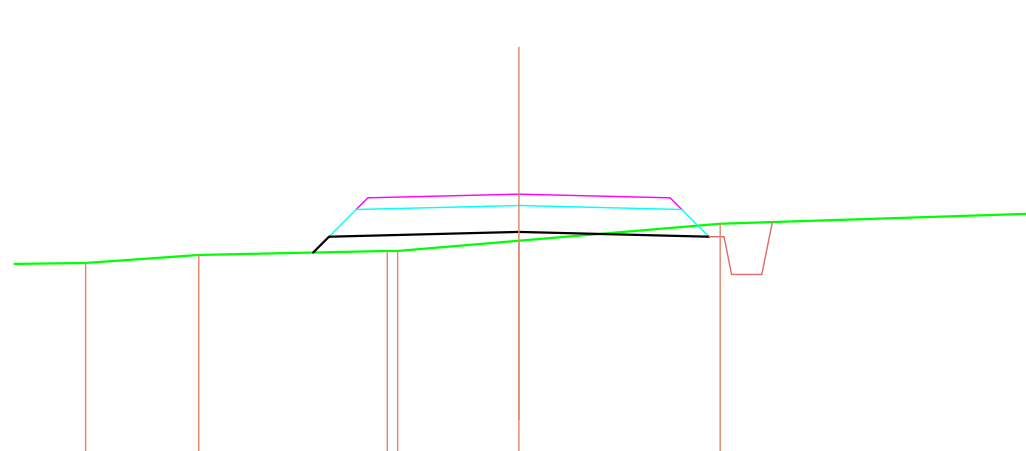

SHKALLA 1:100

KUOTA REF. I219.727

| | | | | | | | |
|---------------------------|--|---------|--------------------|--------------------|---------|---------|--|
| KUOTA E TOKES | | I222.29 | I222.39 | I222.44 I222.44 | I222.58 | I222.80 | |
| DIST. PJESORE E TOKES | | 1.5 | 2.5 | 1.6 | 2.7 | 6.2 | |
| KUOTA E PROJEKTIT | | | I222.42 I222.63 | | I222.70 | I222.63 | |
| DIST. PJESORE E PROJEKTIT | | | 0.2 | 2.5 | 2.5 | | |

SEKSIONI NR. : 48
 KUOTA PROJEKTIT : I224.467
 PROGRESIVA : I175.000

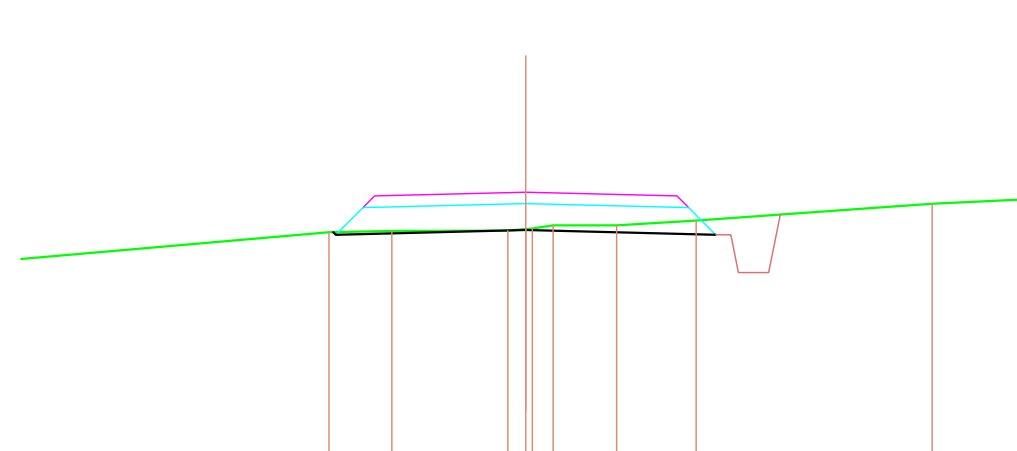

SHKALLA 1:100

KUOTA REF. I220.973

| | | | | | | | |
|---------------------------|--|--------------------|---------|--|---------|---------|---------|
| KUOTA E TOKES | | I223.94 | I223.95 | I223.96 I223.98 I223.99 I224.03 | I224.03 | I224.09 | I224.31 |
| DIST. PJESORE E TOKES | | 5.8 | 0.8 | 1.5 | | | |
| KUOTA E PROJEKTIT | | I223.94 I223.90 | | | | | |
| DIST. PJESORE E PROJEKTIT | | | 2.5 | | | | |



BASHKIA LIBOHOVE
 OBJEKTI:
 RIPARIMIN DHE ASFALTIM I RRUGËS
 AUTOMOBILIS TIKE FUSHA E ÇAJUPIT – TOPOVË,
 PJESË E UNAZËS SË ZAGORISË L= 8971 ML.

Data:
06/2024

EMERTIMI I FLETES:
 PROFIL TERTHOR

SHK
1:1000

HARTOI: SEKTORI SHERBIMIT URBAN
 ARK. NELSON SEJDO

Nr. fleta
12

SEKSIONI NR. : 49
 KUOTA PROJEKTIT : I225.121
 PROGRESIVA : I200.000

SEKSIONI NR. : 51
 KUOTA PROJEKTIT : I226.429
 PROGRESIVA : I250.000

SHKALLA 1:100

SHKALLA 1:100

KUOTA REF. I221.735

KUOTA REF. I222.645

| | | | | | | | |
|---------------------------|--------------------|---------|---------|---------|---------|---------|--|
| KUOTA E TOKES | I224.61 | I224.57 | I224.57 | I224.57 | I224.61 | I224.86 | |
| DIST. PJESORE E TOKES | 1.0 | 0.6 | 0.5 | 1.1 | 1.8 | 4.1 | |
| KUOTA E PROJEKTIT | I224.55 I224.56 | I224.62 | I224.56 | | | | |
| DIST. PJESORE E PROJEKTIT | 2.5 | 2.5 | | | | | |

| | | | | | | | |
|---------------------------|--------------------|---------|--------------------|---------|---------|---------|---------|
| KUOTA E TOKES | I225.69 | I225.75 | I225.80 | I225.82 | I225.84 | I225.83 | I226.03 |
| DIST. PJESORE E TOKES | 2.4 | 0.5 | 0.3 | 0.4 | 2.1 | 2.6 | |
| KUOTA E PROJEKTIT | I225.70 I225.87 | I225.93 | I225.87 I225.85 | | | | |
| DIST. PJESORE E PROJEKTIT | 0.2 | 2.5 | 2.5 | | | | |

SEKSIONI NR. : 50
 KUOTA PROJEKTIT : I225.775
 PROGRESIVA : I225.000

SEKSIONI NR. : 52
 KUOTA PROJEKTIT : I227.083
 PROGRESIVA : I275.000

SHKALLA 1:100

SHKALLA 1:100

KUOTA REF. I222.279

KUOTA REF. I223.413

| | | | | | | | | |
|---------------------------|--------------------|---------|--------------------|---------|---------|---------|---------|---------|
| KUOTA E TOKES | I225.18 | I225.16 | I225.17 | I225.19 | I225.18 | I225.17 | I225.32 | I225.52 |
| DIST. PJESORE E TOKES | 0.6 | 0.3 | 0.4 | 1.0 | 1.1 | 1.0 | 2.2 | |
| KUOTA E PROJEKTIT | I225.08 I225.21 | I225.27 | I225.21 I225.18 | | | | | |
| DIST. PJESORE E PROJEKTIT | 2.5 | 2.5 | | | | | | |

| | | | | | | | |
|---------------------------|--------------------|---------|---------|---------|---------|---------|---------|
| KUOTA E TOKES | I226.26 | I226.31 | I226.42 | I226.43 | I226.54 | I226.54 | I226.54 |
| DIST. PJESORE E TOKES | 4.0 | 1.0 | 2.0 | | | | |
| KUOTA E PROJEKTIT | I226.29 I226.52 | | | | | | |
| DIST. PJESORE E PROJEKTIT | 0.2 | 2.5 | | | | | |



BASHKIA LIBOHOVE

OBJEKTI:
 RIPARIMIN DHE ASFALTIM I RRUGËS
 AUTOMOBILIS TIKE FUSHA E ÇAJUPIT – TOPOVË,
 PJESË E UNAZËS SË ZAGORISË L= 8971 ML.

Data:
 06/2024

EMERTIMI I FLETES:
 PROFIL TERTHOR

SHK
 1:1000

HARTOI: SEKTORI SHERBIMIT URBAN
 ARK. NELSON SEJDO

Nr. fleta
 13

SEKSIONI NR. : 53
 KUOTA PROJEKTIT : 1227.738
 PROGRESIVA : 1300.000

SEKSIONI NR. : 55
 KUOTA PROJEKTIT : 1229.440
 PROGRESIVA : 1350.000

SHKALLA 1:100

SHKALLA 1:100

KUOTA REF. 1224.355

KUOTA REF. 1225.821

| | | | | | | | |
|---------------------------|---------|--------------------|---------|---------|---------|---------|---------|
| KUOTA E TOKES | 1227.01 | 1227.24 | 1227.26 | 1227.25 | 1227.24 | 1227.26 | 1227.44 |
| DIST. PJESORE E TOKES | 3.9 | 1.1 | 0.6 | 0.9 | 4.0 | 4.0 | |
| KUOTA E PROJEKTIT | | 1227.19 1227.18 | 1227.24 | 1227.18 | | | |
| DIST. PJESORE E PROJEKTIT | | 2.5 | 2.5 | | | | |

| | | | | | | | | | | |
|---------------------------|---------|--------------------|---------|---------|---------|---------|---------|---------|---------|---------|
| KUOTA E TOKES | 1228.45 | 1228.58 | 1228.90 | 1228.98 | 1229.01 | 1228.95 | 1228.95 | 1228.91 | 1229.05 | 1229.00 |
| DIST. PJESORE E TOKES | 1.8 | 4.0 | 0.7 | 0.3 | 1.5 | 1.3 | 2.1 | 0.5 | 1.6 | |
| KUOTA E PROJEKTIT | | 1228.74 1228.88 | 1228.94 | 1228.88 | | | | | | |
| DIST. PJESORE E PROJEKTIT | | 2.5 | 2.5 | | | | | | | |

SEKSIONI NR. : 54
 KUOTA PROJEKTIT : 1228.499
 PROGRESIVA : 1325.000

SEKSIONI NR. : 56
 KUOTA PROJEKTIT : 1230.559
 PROGRESIVA : 1375.000

SHKALLA 1:100

SHKALLA 1:100

KUOTA REF. 1225.208

KUOTA REF. 1227.289

| | | | | | | | |
|---------------------------|--------------------|---------|---------|---------|---------|---------|---------|
| KUOTA E TOKES | 1228.11 | 1228.10 | 1228.12 | 1228.15 | 1228.17 | 1228.07 | 1228.31 |
| DIST. PJESORE E TOKES | 7.4 | 0.6 | 0.8 | 1.4 | 0.7 | 1.7 | 4.4 |
| KUOTA E PROJEKTIT | 1228.04 1227.94 | 1228.00 | 1227.94 | | | | |
| DIST. PJESORE E PROJEKTIT | 2.5 | 2.5 | | | | | |

| | | | | | | | | | |
|---------------------------|--------------------|---------|---------|---------|---------|---------|---------|---------|---------|
| KUOTA E TOKES | 1230.29 | 1230.21 | 1229.97 | 1229.94 | 1229.91 | 1229.88 | 1229.95 | 1230.27 | 1230.08 |
| DIST. PJESORE E TOKES | 0.6 | 3.2 | 0.6 | 1.6 | | | | | |
| KUOTA E PROJEKTIT | 1229.99 1230.00 | | | | | | | | |
| DIST. PJESORE E PROJEKTIT | 2.5 | | | | | | | | |



BASHKIA LIBOHOVE
 OBJEKTI:
 RIPARIMIN DHE ASFALTIM I RRUGËS
 AUTOMOBILIS TIKE FUSHA E ÇAJUPIT – TOPOVË,
 PJESË E UNAZËS SË ZAGORISË L= 8971 ML.

Data:
06/2024

EMERTIMI I FLETES:
 PROFIL TERTHOR

SHK
1:1000

HARTOI: SEKTORI SHERBIMIT URBAN
 ARK. NELSON SEJDO

Nr. fleta
14

SEKSIONI NR. : 57
 KUOTA PROJEKTIT : I231.858
 PROGRESIVA : I400.000

SEKSIONI NR. : 59
 KUOTA PROJEKTIT : I234.772
 PROGRESIVA : I450.000

SHKALLA 1:100

SHKALLA 1:100

KUOTA REF. I228.517

KUOTA REF. I231.359

| | | | | | | | | | |
|---------------------------|---------|---------|---------|---------|---------|---------|---------|---------|---------|
| KUOTA E TOKES | I231.93 | I231.43 | I231.42 | I231.14 | I231.13 | I231.11 | I231.10 | I231.11 | I231.19 |
| DIST. PJESORE E TOKES | 3.5 | 0.5 | 2.7 | 1.3 | 0.2 | 0.5 | 4.2 | | |
| KUOTA E PROJEKTIT | | I231.41 | I231.29 | I231.36 | | I231.29 | I231.12 | | |
| DIST. PJESORE E PROJEKTIT | | | 2.5 | 2.5 | 0.2 | | | | |

| | | | | | | | | | | |
|---------------------------|---------|---------|---------|---------|---------|---------|---------|---------|---------|---------|
| KUOTA E TOKES | I234.76 | I234.62 | I234.28 | I234.22 | I234.15 | I234.09 | I234.18 | I234.23 | I234.16 | I234.47 |
| DIST. PJESORE E TOKES | 2.2 | 2.1 | 0.9 | 1.2 | 1.1 | 0.8 | 1.3 | 1.0 | 2.1 | 0.7 |
| KUOTA E PROJEKTIT | | | I234.37 | I234.21 | I234.27 | | I234.21 | I234.20 | | |
| DIST. PJESORE E PROJEKTIT | | | 0.2 | 2.5 | 2.5 | | | | | |

SEKSIONI NR. : 58
 KUOTA PROJEKTIT : I233.306
 PROGRESIVA : I425.000

SEKSIONI NR. : 60
 KUOTA PROJEKTIT : I236.237
 PROGRESIVA : I475.000

SHKALLA 1:100

SHKALLA 1:100

KUOTA REF. I230.070

KUOTA REF. I233.312

| | | | | | | | | | |
|---------------------------|---------|---------|---------|---------|---------|---------|---------|---------|--|
| KUOTA E TOKES | I233.12 | I233.06 | I232.94 | I232.89 | I232.88 | I232.80 | I232.88 | I232.88 | |
| DIST. PJESORE E TOKES | 1.6 | 0.9 | 4.3 | 1.0 | 1.2 | 0.9 | 0.2 | 3.3 | |
| KUOTA E PROJEKTIT | | I232.92 | I232.74 | I232.81 | | I232.74 | | | |
| DIST. PJESORE E PROJEKTIT | | 0.2 | 2.5 | 2.5 | | | | | |

| | | | | | | | | | |
|---------------------------|---------|---------|---------|---------|---------|---------|---------|---------|---------|
| KUOTA E TOKES | I236.04 | I235.93 | I235.60 | I235.66 | I235.80 | I235.76 | I235.78 | I235.95 | I236.30 |
| DIST. PJESORE E TOKES | 2.4 | 0.6 | 3.1 | | | | | | |
| KUOTA E PROJEKTIT | | | I235.81 | I235.67 | | | | | |
| DIST. PJESORE E PROJEKTIT | | | 2.5 | | | | | | |

BASHKIA LIBOHOVE

OBJEKTI:
 RIPARIMIN DHE ASFALTIM I RRUGËS
 AUTOMOBILIS TIKE FUSHA E ÇAJUPIT – TOPOVË,
 PJESË E UNAZËS SË ZAGORISË L= 8971 ML.

EMERTIMI I FLETES:
 PROFIL TERTHOR

HARTOI: SEKTORI SHERBIMIT URBAN
 ARK. NELSON SEJDO

Data: 06/2024
 SHK 1:1000
 Nr. fleta 15

SEKSIONI NR. : 61
 KUOTA PROJEKTIT : 1237.702
 PROGRESIVA : 1500.000

SEKSIONI NR. : 63
 KUOTA PROJEKTIT : 1240.633
 PROGRESIVA : 1550.000

SHKALLA 1:100

SHKALLA 1:100

KUOTA REF. 1234.454

KUOTA REF. 1237.265

| | | | | | | | | | |
|---------------------------|--------------------|---------|--------------------|---------|---------|---------|---------|---------|-----|
| KUOTA E TOKES | 1238.11 1237.97 | 1237.34 | 1237.19 | 1237.09 | 1237.29 | 1237.48 | 1237.54 | 1237.61 | |
| DIST. PJESORE E TOKES | 0.3 | 2.0 | 1.6 | 0.9 | 1.3 | 1.4 | 0.7 | 0.5 | 6.2 |
| KUOTA E PROJEKTIT | | | 1237.23 1237.14 | | 1237.20 | | | 1237.14 | |
| DIST. PJESORE E PROJEKTIT | | | | 2.5 | | 2.5 | | | |

| | | | | | | | | | |
|---------------------------|-----|---------|-------------------------------|--------------------|---------|--------------------|---------|---------|-----|
| KUOTA E TOKES | | 1240.19 | 1239.78 1239.76 1239.82 | 1239.72 1239.71 | 1239.90 | 1239.97 | 1240.44 | 1240.49 | |
| DIST. PJESORE E TOKES | 3.5 | 2.0 | 0.2 0.3 | 1.7 | 0.2 | 2.3 | 1.3 | 1.3 | 0.8 |
| KUOTA E PROJEKTIT | | | 1239.89 1240.07 | 1240.13 | | 1240.07 1239.91 | | | |
| DIST. PJESORE E PROJEKTIT | | | 0.2 | 2.5 | | 2.5 | | | |

SEKSIONI NR. : 62
 KUOTA PROJEKTIT : 1239.168
 PROGRESIVA : 1525.000

SEKSIONI NR. : 64
 KUOTA PROJEKTIT : 1242.098
 PROGRESIVA : 1575.000

SHKALLA 1:100

SHKALLA 1:100

KUOTA REF. 1235.852

KUOTA REF. 1238.851

| | | | | | | | |
|---------------------------|-----|-------------------------------|--------------------|---------|-------------------------------|------------|-----|
| KUOTA E TOKES | | 1238.62 1238.64 1238.61 | 1238.40 | 1238.71 | 1239.05 1239.04 1239.05 | 1239.10 | |
| DIST. PJESORE E TOKES | 2.6 | 0.3 | 2.1 | 2.0 | 2.1 | 0.2 0.9 | 5.2 |
| KUOTA E PROJEKTIT | | | 1238.47 1238.60 | 1238.67 | | 1238.60 | |
| DIST. PJESORE E PROJEKTIT | | | | 2.5 | | 2.5 | |

| | | | | | | | | | |
|---------------------------|-----|---------|--------------------|--------------------|---------|--------------------|---------|---------|---------|
| KUOTA E TOKES | | 1241.64 | 1241.42 | 1241.31 1241.37 | 1241.44 | 1241.41 1241.40 | 1241.47 | 1241.76 | 1242.16 |
| DIST. PJESORE E TOKES | 4.9 | 1.4 | 0.7 | 0.5 | 0.7 | 0.6 0.9 | 1.5 | 1.6 | |
| KUOTA E PROJEKTIT | | | 1241.43 1241.54 | | | | | | |
| DIST. PJESORE E PROJEKTIT | | | | 2.5 | | | | | |

BASHKIA LIBOHOVE

OBJEKTI:
 RIPARIMIN DHE ASFALTIM I RRUGËS
 AUTOMOBILIS TIKE FUSHA E ÇAJUPIT – TOPOVË,
 PJESË E UNAZËS SË ZAGORISË L= 8971 ML.

EMERTIMI I FLETES:
 PROFIL TERTHOR

HARTOI: SEKTORI SHERBIMIT URBAN
 ARK. NELSON SEJDO

Data:
 06/2024

SHK
 1:1000

Nr. fleta
 16

SEKSIONI NR. : 65
 KUOTA PROJEKTIT : 1243.911
 PROGRESIVA : 1600.000

SHKALLA 1:100

KUOTA REF. 1240.398

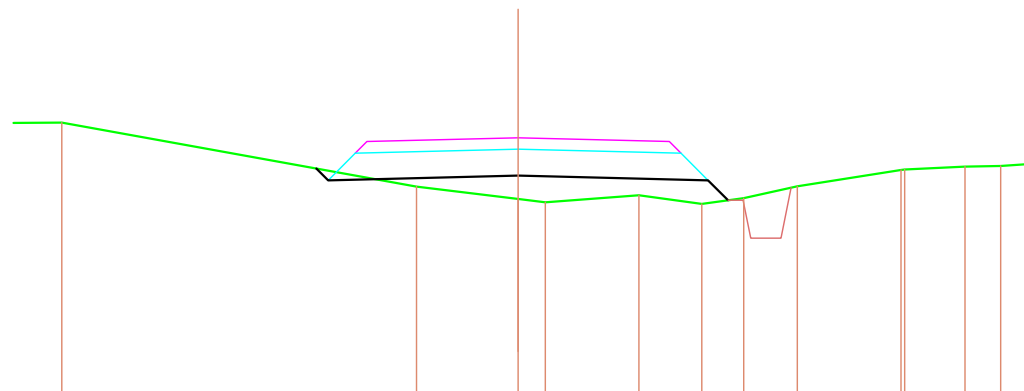

| | | | | | | | | | | | | |
|---------------------------|---------|--------------------|---------|---------|--------------------|---------|---------|---------|---------|---------|---------|---------|
| KUOTA E TOKES | 1244.11 | 1243.27 | 1243.10 | 1243.06 | 1243.15 | 1243.04 | 1243.11 | 1243.27 | 1243.48 | 1243.49 | 1243.55 | 1243.54 |
| DIST. PJESORE E TOKES | 4.7 | 1.3 | 0.4 | 1.2 | 0.8 | 0.6 | 0.7 | 1.4 | 0.8 | 0.5 | | |
| KUOTA E PROJEKTIT | | 1243.50 1243.35 | 1243.41 | | 1243.35 1243.08 | | | | | | | |
| DIST. PJESORE E PROJEKTIT | | 2.5 | 2.5 | | 0.3 | | | | | | | |

SEKSIONI NR. : 67
 KUOTA PROJEKTIT : 1247.997
 PROGRESIVA : 1650.000

SHKALLA 1:100

KUOTA REF. 1247.056

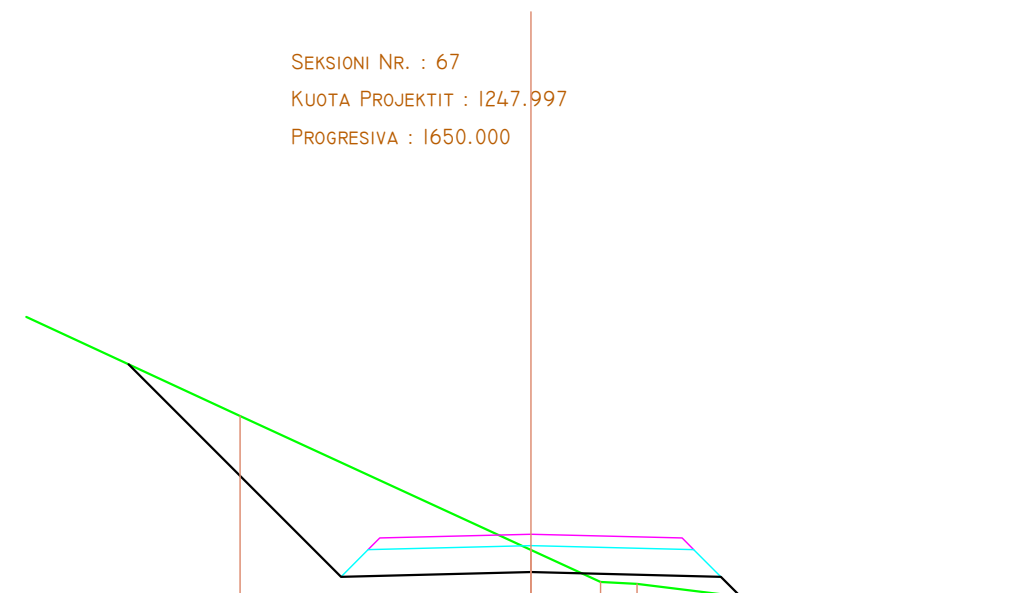

| | | | | | |
|---------------------------|---------|---------|---------|--------------------|---------|
| KUOTA E TOKES | 1249.56 | 1247.79 | 1247.37 | 1247.34 | 1247.00 |
| DIST. PJESORE E TOKES | 3.8 | 0.9 | 0.5 | 2.7 | 5.1 |
| KUOTA E PROJEKTIT | 1250.24 | 1247.43 | 1247.50 | 1247.43 1247.17 | |
| DIST. PJESORE E PROJEKTIT | 2.8 | 2.5 | 2.5 | 0.3 | |

SEKSIONI NR. : 66
 KUOTA PROJEKTIT : 1246.193
 PROGRESIVA : 1625.000

SHKALLA 1:100

KUOTA REF. 1244.704

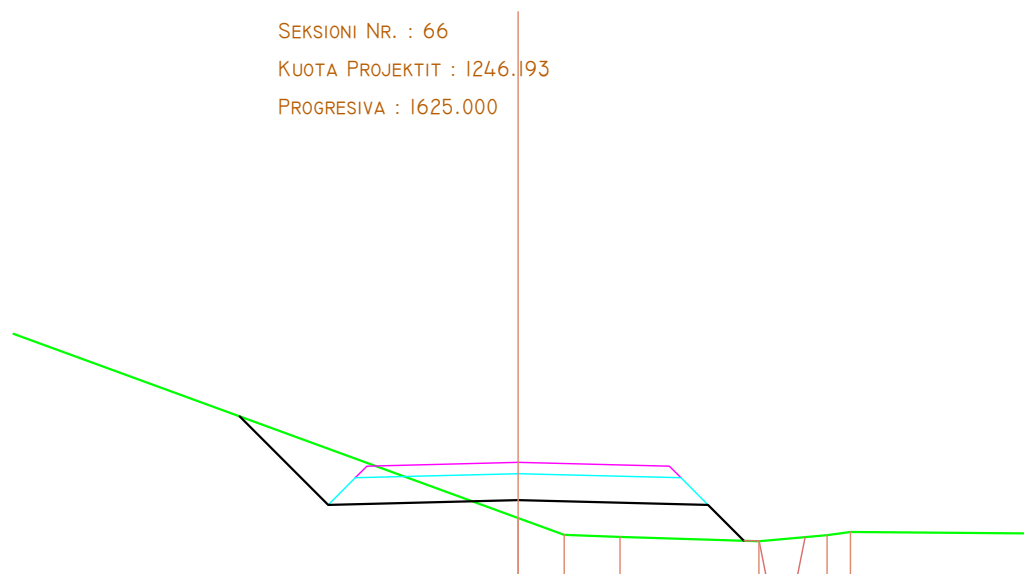

| | | | | | | | |
|---------------------------|---------|---------|---------|---------|---------|---------|-----|
| KUOTA E TOKES | 1245.46 | 1245.24 | 1245.21 | 1245.15 | 1245.23 | 1245.27 | |
| DIST. PJESORE E TOKES | 10.5 | 0.6 | 0.7 | 1.8 | 0.9 | 0.3 | 2.4 |
| KUOTA E PROJEKTIT | 1246.80 | 1245.63 | 1245.69 | 1245.65 | 1245.16 | | |
| DIST. PJESORE E PROJEKTIT | 1.2 | 2.5 | 2.5 | 0.5 | | | |

SEKSIONI NR. : 68
 KUOTA PROJEKTIT : 1249.062
 PROGRESIVA : 1675.000

SHKALLA 1:100

KUOTA REF. 1247.683

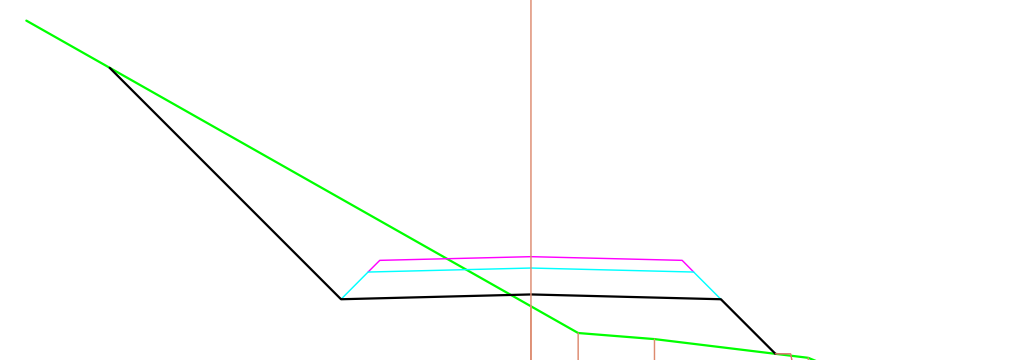

| | | | | | |
|---------------------------|---------|---------|---------|---------|---------|
| KUOTA E TOKES | 1248.41 | 1248.05 | 1247.97 | 1247.75 | 1246.85 |
| DIST. PJESORE E TOKES | 7.0 | | | | |
| KUOTA E PROJEKTIT | 1251.56 | 1248.50 | | | |
| DIST. PJESORE E PROJEKTIT | 3.1 | 2.5 | | | |



BASHKIA LIBOHOVE

OBJEKTI:
 RIPARIMIN DHE ASFALTIM I RRUGËS
 AUTOMOBILIS TIKE FUSHA E ÇAJUPIT – TOPOVË,
 PJESË E UNAZËS SË ZAGORISË L= 8971 ML.

Data:
 06/2024

EMERTIMI I FLETES:
 PROFIL TERTHOR

SHK
 1:1000

HARTOI: SEKTORI SHERBIMIT URBAN
 ARK. NELSON SEJDO

Nr. fleta
 17

SEKSIONI NR. : 69
 KUOTA PROJEKTIT : 1249.391
 PROGRESIVA : 1700.000

SEKSIONI NR. : 71
 KUOTA PROJEKTIT : 1248.250
 PROGRESIVA : 1750.000

SHKALLA 1:100

SHKALLA 1:100

KUOTA REF. 1248.477

KUOTA REF. 1247.380

| | | | | | | |
|---------------------------|---------|---------|---------|---------|---------|--|
| KUOTA E TOKES | | 1248.92 | 1248.59 | 1248.42 | 1248.36 | |
| DIST. PJESORE E TOKES | 8.0 | 0.6 | 2.2 | 0.5 | 4.5 | |
| KUOTA E PROJEKTIT | 1252.32 | 1248.83 | 1248.89 | 1248.83 | 1248.39 | |
| DIST. PJESORE E PROJEKTIT | 3.5 | 2.5 | 2.5 | 0.4 | | |

| | | | | | | | | |
|---------------------------|---------|---------|---------|---------|---------|---------|---------|--|
| KUOTA E TOKES | | 1250.17 | 1247.85 | 1247.81 | 1247.76 | 1247.59 | 1247.28 | |
| DIST. PJESORE E TOKES | 5.6 | 0.4 | 0.5 | 1.9 | 1.5 | 4.7 | | |
| KUOTA E PROJEKTIT | 1249.46 | 1247.69 | 1247.75 | 1247.69 | 1247.53 | | | |
| DIST. PJESORE E PROJEKTIT | 1.8 | 2.5 | 2.5 | | | | | |

SEKSIONI NR. : 70
 KUOTA PROJEKTIT : 1248.986
 PROGRESIVA : 1725.000

SEKSIONI NR. : 72
 KUOTA PROJEKTIT : 1247.515
 PROGRESIVA : 1775.000

SHKALLA 1:100

SHKALLA 1:100

KUOTA REF. 1248.210

KUOTA REF. 1246.209

| | | | | | | | |
|---------------------------|---------|---------|---------|---------|---------|---------|---------|
| KUOTA E TOKES | | 1246.57 | 1246.45 | 1246.17 | 1246.11 | 1247.85 | 1247.79 |
| DIST. PJESORE E TOKES | 7.0 | 0.2 | 1.6 | 0.7 | 1.4 | 0.9 | |
| KUOTA E PROJEKTIT | 1251.78 | 1248.42 | 1248.49 | 1248.42 | 1248.03 | | |
| DIST. PJESORE E PROJEKTIT | 3.4 | 2.5 | 2.5 | 0.4 | | | |

| | | | | | | | |
|---------------------------|---------|---------|---------|---------|---------|---------|---------|
| KUOTA E TOKES | | 1247.34 | 1247.27 | 1247.27 | 1247.06 | 1246.77 | 1246.10 |
| DIST. PJESORE E TOKES | 9.8 | 0.8 | 1.9 | 1.2 | 3.1 | | |
| KUOTA E PROJEKTIT | 1248.57 | 1246.95 | | | | | |
| DIST. PJESORE E PROJEKTIT | 1.6 | 2.5 | | | | | |



BASHKIA LIBOHOVE

OBJEKTI:
 RIPARIMIN DHE ASFALTIM I RRUGËS
 AUTOMOBILIS TIKE FUSHA E ÇAJUPIT – TOPOVË,
 PJESË E UNAZËS SË ZAGORISË L= 8971 ML.

Data:

06/2024

EMERTIMI I FLETES:

PROFIL TERTHOR

SHK
 1:1000

HARTOI: SEKTORI SHERBIMIT URBAN
 ARK. NELSON SEJDO

Nr. fleta

18

SEKSIONI NR. : 73
 KUOTA PROJEKTIT : 1246.717
 PROGRESIVA : 1800.000

SEKSIONI NR. : 75
 KUOTA PROJEKTIT : 1241.643
 PROGRESIVA : 1850.000

SHKALLA 1:100

SHKALLA 1:100

KUOTA REF. 1245.360

KUOTA REF. 1241.231

| | | | | | |
|---------------------------|-----|---------|--------------------|---------|--------------------|
| KUOTA E TOKES | | 1246.31 | 1246.18 1246.18 | 1246.03 | |
| DIST. PJESORE E TOKES | 8.0 | 1.5 | 1.4 | 5.2 | |
| KUOTA E PROJEKTIT | | 1247.11 | 1246.15 | 1246.22 | 1246.15 1245.84 |
| DIST. PJESORE E PROJEKTIT | | 1.0 | 2.5 | 2.5 | 0.3 |

| | | | | | | | | | | | | |
|---------------------------|-----|---------|---------|---------|---------|---------|---------|---------|---------|---------|---------|---------|
| KUOTA E TOKES | | 1243.21 | 1242.34 | 1241.76 | 1241.71 | 1241.62 | 1241.51 | 1241.55 | 1241.59 | 1241.62 | 1241.96 | 1241.86 |
| DIST. PJESORE E TOKES | 3.1 | 2.1 | 0.8 | 0.3 | 0.8 | 0.9 | 1.3 | 0.3 | 2.0 | 0.6 | | |
| KUOTA E PROJEKTIT | | 1243.76 | 1241.08 | | | 1241.14 | | | 1241.08 | | | |
| DIST. PJESORE E PROJEKTIT | | 2.7 | 2.5 | | | 2.5 | | | | | | |

SEKSIONI NR. : 74
 KUOTA PROJEKTIT : 1244.868
 PROGRESIVA : 1825.000

SEKSIONI NR. : 76
 KUOTA PROJEKTIT : 1237.901
 PROGRESIVA : 1875.000

SHKALLA 1:100

SHKALLA 1:100

KUOTA REF. 1244.255

KUOTA REF. 1235.300

| | | | | | |
|---------------------------|-----|--------------------|---------|-------------------------------|---------|
| KUOTA E TOKES | | 1247.51 1247.47 | | 1244.77 1244.72 1244.69 | 1244.60 |
| DIST. PJESORE E TOKES | 0.3 | 6.1 | 1.8 | 8.1 | |
| KUOTA E PROJEKTIT | | 1247.00 | 1244.31 | 1244.37 | 1244.31 |
| DIST. PJESORE E PROJEKTIT | | 2.7 | 2.5 | 2.5 | |

| | | | | | | |
|---------------------------|-----|---------|---------|---------|--------------------|---------|
| KUOTA E TOKES | | 1237.15 | 1237.17 | 1237.06 | 1237.30 1237.32 | 1237.84 |
| DIST. PJESORE E TOKES | 2.4 | 2.0 | 0. | | | |
| KUOTA E PROJEKTIT | | 1237.17 | 1237.34 | | | |
| DIST. PJESORE E PROJEKTIT | | 0.2 | 2.5 | | | |



BASHKIA LIBOHOVE

OBJEKTI:
 RIPARIMIN DHE ASFALTIM I RRUGËS
 AUTOMOBILIS TIKE FUSHA E ÇAJUPIT – TOPOVË,
 PJESË E UNAZËS SË ZAGORISË L= 8971 ML.

Data:

06/2024

EMERTIMI I FLETES:

PROFIL TERTHOR

SHK
 1:1000

HARTOI: SEKTORI SHERBIMIT URBAN
 ARK. NELSON SEJDO

Nr. fleta

19

SEKSIONI NR. : 77
 KUOTA PROJEKTIT : 1234.158
 PROGRESIVA : 1900.000

SEKSIONI NR. : 79
 KUOTA PROJEKTIT : 1226.672
 PROGRESIVA : 1950.000

SHKALLA 1:100

SHKALLA 1:100

KUOTA REF. 1230.610

KUOTA REF. 1222.558

| | | | | | | | | | | | |
|---------------------------|--|---------|---------|---------|---------|---------|---------|---------|--|---------|-----|
| KUOTA E TOKES | | 1232.92 | 1233.19 | | 1233.30 | 1233.40 | 1233.50 | 1233.51 | | 1235.82 | |
| DIST. PJESORE E TOKES | | 0.6 | 1.7 | | 1.3 | 0.8 | | | | 5.1 | 2.3 |
| KUOTA E PROJEKTIT | | | 1233.25 | 1233.60 | | | 1233.66 | | | 1233.60 | |
| DIST. PJESORE E PROJEKTIT | | | 0.3 | | 2.5 | | | 2.5 | | | |

| | | | | | | | | | | | | | |
|---------------------------|--|---------|---------|---------|---------|---------|---------|---------|-----|---------|---------|---------|---------|
| KUOTA E TOKES | | 1224.19 | | 1224.62 | 1224.94 | 1224.93 | 1224.89 | 1224.88 | | 1225.00 | | 1226.54 | 1226.79 |
| DIST. PJESORE E TOKES | | 2.1 | | 1.5 | 0.8 | 1.5 | 1.1 | 0.3 | 1.9 | | 3.5 | 0.5 | 0.9 |
| KUOTA E PROJEKTIT | | | 1224.39 | | 1226.11 | | | 1226.17 | | 1226.11 | 1225.45 | | |
| DIST. PJESORE E PROJEKTIT | | | | 1.7 | | 2.5 | | | 2.5 | 0.7 | | | |

SEKSIONI NR. : 78
 KUOTA PROJEKTIT : 1230.415
 PROGRESIVA : 1925.000

SEKSIONI NR. : 80
 KUOTA PROJEKTIT : 1222.930
 PROGRESIVA : 1975.000

SHKALLA 1:100

SHKALLA 1:100

KUOTA REF. 1227.129

KUOTA REF. 1220.514

| | | | | | | | | | | | | | |
|---------------------------|--|---------|--|---------|---------|---------|---------|--|---------|---------|---------|---------|---------|
| KUOTA E TOKES | | 1228.43 | | 1229.19 | 1229.31 | 1229.32 | 1229.33 | | 1229.22 | 1229.21 | 1229.18 | 1229.48 | |
| DIST. PJESORE E TOKES | | 2.2 | | 0.2 | 0.2 | | | | 2.7 | 0.5 | 1.4 | 1.2 | |
| KUOTA E PROJEKTIT | | | | 1229.32 | 1229.85 | | | | 1229.92 | | | 1229.85 | 1229.54 |
| DIST. PJESORE E PROJEKTIT | | | | 0.5 | | | | | 2.5 | | 2.5 | 0.3 | |

| | | | | | | | | | | | | |
|---------------------------|--|--|--|--|---------|---------|---------|---------|---------|---------|---------|--|
| KUOTA E TOKES | | | | | 1221.95 | 1222.07 | 1222.15 | 1222.12 | 1222.94 | 1224.32 | 1224.82 | |
| DIST. PJESORE E TOKES | | | | | 6.1 | | | 1.3 | | | | |
| KUOTA E PROJEKTIT | | | | | 1221.62 | 1222.37 | | | | | | |
| DIST. PJESORE E PROJEKTIT | | | | | 0.8 | | | 2.5 | | | | |



BASHKIA LIBOHOVE
 OBJEKTI:
 RIPARIMIN DHE ASFALTIM I RRUGËS
 AUTOMOBILIS TIKE FUSHA E ÇAJUPIT – TOPOVË,
 PJESË E UNAZËS SË ZAGORISË L= 8971 ML.

EMERTIMI I FLETES:
 PROFIL TERTHOR

HARTOI: SEKTORI SHERBIMIT URBAN
 ARK. NELSON SEJDO

Data:
 06/2024
 SHK
 1:1000
 Nr. fleta
 20

SEKSIONI NR. : 81
 KUOTA PROJEKTIT : 1219.167
 PROGRESIVA : 2000.000

SEKSIONI NR. : 83
 KUOTA PROJEKTIT : 1210.163
 PROGRESIVA : 2050.000

SHKALLA 1:100

SHKALLA 1:100

KUOTA REF. 1216.013

KUOTA REF. 1207.861

| | | | | | | | |
|---------------------------|-----|---------|---------|---------|---------|---------|--|
| KUOTA E TOKES | | 1218.31 | 1218.30 | 1218.31 | 1218.37 | 1218.49 | |
| DIST. PJESORE E TOKES | 5.7 | 0.5 | 0.4 | 1.1 | 2.2 | 4.9 | |
| KUOTA E PROJEKTIT | | 1217.75 | 1218.60 | 1218.67 | 1218.60 | | |
| DIST. PJESORE E PROJEKTIT | | 0.9 | 2.5 | 2.5 | | | |

| | | | | | | | | |
|---------------------------|--|---------|---------|---------|---------|---------|---------|---------|
| KUOTA E TOKES | | 1210.29 | 1211.41 | 1211.41 | 1211.19 | 1211.25 | 1211.14 | 1211.08 |
| DIST. PJESORE E TOKES | | 5.3 | 1.4 | 1.8 | 1.4 | 0.9 | 2.7 | |
| KUOTA E PROJEKTIT | | 1209.66 | 1209.60 | 1209.66 | 1209.60 | | | |
| DIST. PJESORE E PROJEKTIT | | 1.1 | 2.5 | 2.5 | | | | |

SEKSIONI NR. : 82
 KUOTA PROJEKTIT : 1214.939
 PROGRESIVA : 2025.000

SEKSIONI NR. : 84
 KUOTA PROJEKTIT : 1205.326
 PROGRESIVA : 2075.000

SHKALLA 1:100

SHKALLA 1:100

KUOTA REF. 1211.300

KUOTA REF. 1200.595

| | | | | | | | | | | |
|---------------------------|-----|---------|---------|---------|---------|---------|---------|---------|---------|-----|
| KUOTA E TOKES | | 1214.05 | 1214.93 | 1214.89 | 1214.89 | 1214.89 | 1214.97 | 1215.89 | 1216.15 | |
| DIST. PJESORE E TOKES | 2.0 | 2.3 | 1.8 | 0.9 | 0.3 | 0.5 | 0.4 | 1.4 | 0.4 | 7.2 |
| KUOTA E PROJEKTIT | | 1214.83 | 1214.38 | 1214.44 | 1214.38 | | | | | |
| DIST. PJESORE E PROJEKTIT | | 0.5 | 2.5 | 2.5 | | | | | | |

| | | | | | | | | |
|---------------------------|--|---------|---------|---------|---------|---------|---------|---------|
| KUOTA E TOKES | | 1203.45 | 1203.13 | 1201.96 | 1201.90 | 1201.63 | 1201.65 | 1201.62 |
| DIST. PJESORE E TOKES | | 0.9 | 2.0 | 2.9 | 0.2 | 1.1 | | |
| KUOTA E PROJEKTIT | | 1204.42 | 1204.76 | | | | | |
| DIST. PJESORE E PROJEKTIT | | 0.3 | 2.5 | | | | | |



BASHKIA LIBOHOVE
 OBJEKTI:
 RIPARIMIN DHE ASFALTIM I RRUGËS
 AUTOMOBILIS TIKE FUSHA E ÇAJUPIT – TOPOVË,
 PJESË E UNAZËS SË ZAGORISË L= 8971 ML.

EMERTIMI I FLETES:
 PROFIL TERTHOR

HARTOI: SEKTORI SHERBIMIT URBAN
 ARK. NELSON SEJDO

Data:
 06/2024
 SHK
 1:1000
 Nr. fleta
 21

SEKSIONI NR. : 85
 KUOTA PROJEKTIT : 1200.490
 PROGRESIVA : 2100.000

SHKALLA 1:100

KUOTA REF. 1197.071

| | | | | | | | | | |
|---------------------------|---------|---------|---------|---------|---------|---------|---------|---------|---------|
| KUOTA E TOKES | 1202.64 | 1201.52 | 1199.97 | 1199.02 | 1198.94 | 1198.89 | 1198.87 | 1198.86 | 1198.65 |
| DIST. PJESORE E TOKES | 2.2 | 2.7 | 1.7 | 1.4 | 1.5 | 0.8 | | | |
| KUOTA E PROJEKTIT | 1202.36 | 1199.93 | 1199.99 | 1199.93 | 1198.93 | | | | |
| DIST. PJESORE E PROJEKTIT | 2.4 | 2.5 | 2.5 | 1.0 | | | | | |

SEKSIONI NR. : 87
 KUOTA PROJEKTIT : 1191.615
 PROGRESIVA : 2150.000

SHKALLA 1:100

KUOTA REF. 1190.255

| | | | | | | | | |
|---------------------------|---------|---------|---------|---------|---------|---------|---------|---------|
| KUOTA E TOKES | 1192.55 | 1191.24 | 1191.17 | 1190.97 | 1190.89 | 1190.91 | 1190.92 | 1190.76 |
| DIST. PJESORE E TOKES | 2.9 | 2.9 | 0.5 | 1.2 | 0.5 | 1.7 | 0.6 | 0.8 |
| KUOTA E PROJEKTIT | 1192.09 | 1191.05 | | 1191.11 | | | 1191.05 | 1190.91 |
| DIST. PJESORE E PROJEKTIT | 1.0 | 2.5 | | 2.5 | | | | |

SEKSIONI NR. : 86
 KUOTA PROJEKTIT : 1195.757
 PROGRESIVA : 2125.000

SHKALLA 1:100

KUOTA REF. 1194.389

| | | | | | | | | | | |
|---------------------------|---------|---------|---------|---------|---------|---------|---------|---------|---------|---------|
| KUOTA E TOKES | 1197.61 | 1196.68 | 1195.91 | 1195.50 | 1195.32 | 1195.29 | 1195.21 | 1195.21 | 1195.23 | 1194.69 |
| DIST. PJESORE E TOKES | 1.7 | 1.3 | 0.9 | 1.3 | 0.2 | 0.5 | 0.5 | 2.2 | 2.8 | |
| KUOTA E PROJEKTIT | 1197.24 | 1195.19 | 1195.26 | 1195.19 | | | | | | |
| DIST. PJESORE E PROJEKTIT | 2.0 | 2.5 | 2.5 | | | | | | | |

SEKSIONI NR. : 88
 KUOTA PROJEKTIT : 1187.878
 PROGRESIVA : 2175.000

SHKALLA 1:100

KUOTA REF. 1184.311

| | | | | | |
|---------------------------|---------|---------|---------|---------|---------|
| KUOTA E TOKES | 1187.36 | 1187.01 | 1187.05 | 1187.05 | 1187.09 |
| DIST. PJESORE E TOKES | 5.2 | 0.9 | 0.4 | | 6.5 |
| KUOTA E PROJEKTIT | 1187.15 | 1187.32 | | | |
| DIST. PJESORE E PROJEKTIT | 0.2 | 2.5 | | | |



BASHKIA LIBOHOVE
 OBJEKTI:
 RIPARIMIN DHE ASFALTIM I RRUGËS
 AUTOMOBILIS TIKE FUSHA E ÇAJUPIT – TOPOVË,
 PJESË E UNAZËS SË ZAGORISË L= 8971 ML.

EMERTIMI I FLETES:
 PROFIL TERTHOR

HARTOI: SEKTORI SHERBIMIT URBAN
 ARK. NELSON SEJDO

Data:
 06/2024
 SHK
 1:1000
 Nr. fleta
 22

SEKSIONI NR. : 89
 KUOTA PROJEKTIT : 1184.166
 PROGRESIVA : 2200.000

SEKSIONI NR. : 91
 KUOTA PROJEKTIT : 1180.025
 PROGRESIVA : 2250.000

SHKALLA 1:100

SHKALLA 1:100

KUOTA REF. 1180.372

KUOTA REF. 1176.851

| | | | | | | | | | | |
|---------------------------|------|---------|---------|---------|-----|---------|---------|---------|---------|---------|
| KUOTA E TOKES | | | | 1183.26 | | 1183.59 | 1183.63 | 1183.65 | 1183.67 | 1183.78 |
| DIST. PJESORE E TOKES | 11.3 | | | 3.2 | 0.5 | 0.3 | 0.2 | | 1.3 | |
| KUOTA E PROJEKTIT | | 1182.93 | 1183.60 | 1183.67 | | 1183.60 | 1183.52 | | | |
| DIST. PJESORE E PROJEKTIT | | 0.7 | 2.5 | 2.5 | | | | | | |

| | | | | | | | |
|---------------------------|-----|---------|---------|---------|---------|---------|---------|
| KUOTA E TOKES | | | | 1179.57 | 1179.71 | | 1180.04 |
| DIST. PJESORE E TOKES | 7.2 | | | 1.2 | 3.0 | | |
| KUOTA E PROJEKTIT | | 1179.25 | 1179.46 | 1179.52 | | 1179.46 | |
| DIST. PJESORE E PROJEKTIT | | 0.2 | 2.5 | 2.5 | | | |

SEKSIONI NR. : 90
 KUOTA PROJEKTIT : 1181.476
 PROGRESIVA : 2225.000

SEKSIONI NR. : 92
 KUOTA PROJEKTIT : 1178.233
 PROGRESIVA : 2275.000

SHKALLA 1:100

SHKALLA 1:100

KUOTA REF. 1178.440

KUOTA REF. 1174.517

| | | | | | | | | |
|---------------------------|--|---------|---------|---------|---------|---------|---------|--|
| KUOTA E TOKES | | 1179.91 | 1179.97 | 1180.02 | 1179.97 | 1180.39 | 1180.94 | |
| DIST. PJESORE E TOKES | | 1.0 | 0.7 | 1.0 | 1.2 | 2.1 | 7.3 | |
| KUOTA E PROJEKTIT | | | | 1179.98 | 1180.91 | 1180.98 | 1180.91 | |
| DIST. PJESORE E PROJEKTIT | | | | 0.9 | 2.5 | 2.5 | | |

| | | | | | | | | | | | |
|---------------------------|-----|--|---------|---------|---------|---------|---------|---------|---------|---------|---------|
| KUOTA E TOKES | | | 1178.23 | 1178.22 | 1178.22 | 1178.26 | 1178.24 | 1178.06 | 1177.99 | 1177.83 | 1177.85 |
| DIST. PJESORE E TOKES | 6.6 | | 1.8 | | | | | | | | |
| KUOTA E PROJEKTIT | | | 1178.06 | 1177.67 | | | | | | | |
| DIST. PJESORE E PROJEKTIT | | | 0.4 | 2.5 | | | | | | | |



BASHKIA LIBOHOVE

OBJEKTI:
 RIPARIMIN DHE ASFALTIM I RRUGËS
 AUTOMOBILIS TIKE FUSHA E ÇAJUPIT – TOPOVË,
 PJESË E UNAZËS SË ZAGORISË L= 8971 ML.

Data:
 06/2024

EMERTIMI I FLETES:
 PROFIL TERTHOR

SHK
 1:1000

HARTOI: SEKTORI SHERBIMIT URBAN
 ARK. NELSON SEJDO

Nr. fleta
 23

SEKSIONI NR. : 93
 KUOTA PROJEKTIT : 1175.605
 PROGRESIVA : 2300.000

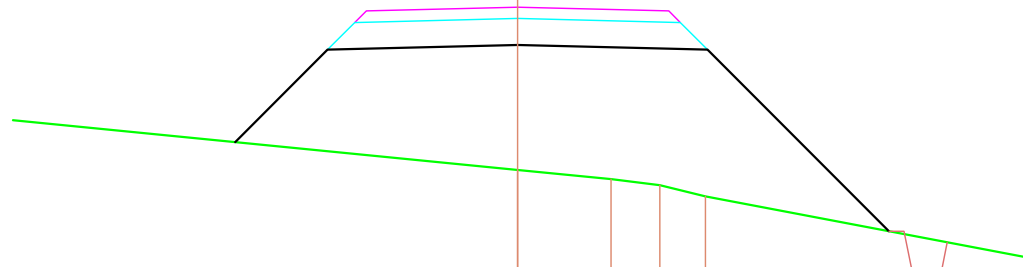

SHKALLA 1:100

KUOTA REF. 1170.522

| | | | | | | | |
|---------------------------|-----|---------|---------|---------|---------|---------|---------|
| KUOTA E TOKES | | | 1173.45 | 1173.33 | 1173.25 | 1173.10 | |
| DIST. PJESORE E TOKES | 9.0 | | 1.2 | 0.6 | 0.6 | | |
| KUOTA E PROJEKTIT | | 1173.82 | 1175.04 | 1175.10 | | 1175.04 | 1172.64 |
| DIST. PJESORE E PROJEKTIT | | 1.2 | 2.5 | 2.5 | | 2.4 | |

SEKSIONI NR. : 95
 KUOTA PROJEKTIT : 1169.717
 PROGRESIVA : 2350.000

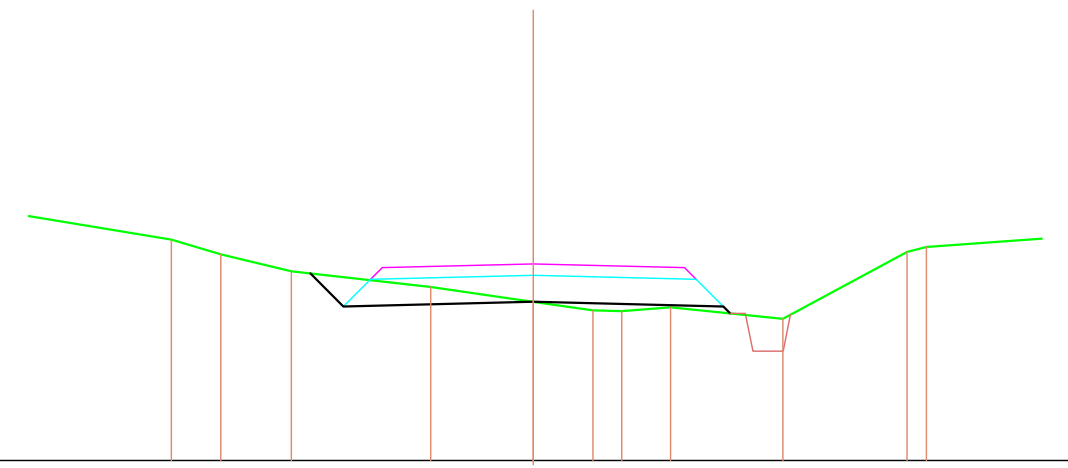

SHKALLA 1:100

KUOTA REF. 1167.118

| | | | | | | | | | | | | | | | | | |
|---------------------------|--|--|--|---------|---------|---------|---------|---------|---------|---------|---------|---------|-----|---------|---------|---------|---------|
| KUOTA E TOKES | | | | 1170.04 | 1169.84 | 1169.62 | | 1169.41 | 1169.22 | 1169.10 | 1169.09 | 1169.14 | | 1168.99 | | 1169.88 | 1169.94 |
| DIST. PJESORE E TOKES | | | | 3.3 | 0.7 | 0.9 | 1.8 | 1.4 | 0.8 | 0.4 | 0.6 | 1.5 | 1.6 | | 0.3 | | |
| KUOTA E PROJEKTIT | | | | | | 1169.59 | 1169.15 | | 1169.22 | | | | | 1169.15 | 1169.00 | | |
| DIST. PJESORE E PROJEKTIT | | | | | | 0.4 | 2.5 | | 2.5 | | | | | | | | |

SEKSIONI NR. : 94
 KUOTA PROJEKTIT : 1172.661
 PROGRESIVA : 2325.000

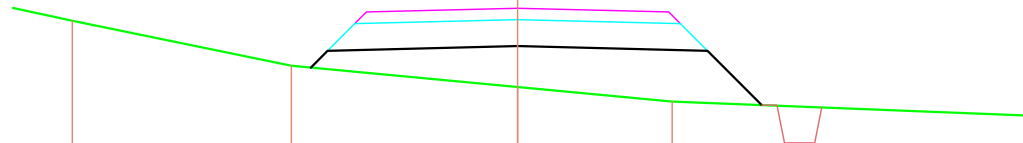

SHKALLA 1:100

KUOTA REF. 1169.649

| | | | | | | | | | | |
|---------------------------|--|---------|---------|---------|--|---------|--|---------|---------|-----|
| KUOTA E TOKES | | 1172.50 | | 1171.90 | | 1171.62 | | 1171.43 | | |
| DIST. PJESORE E TOKES | | 2.9 | | 3.0 | | 2.0 | | | | 8.5 |
| KUOTA E PROJEKTIT | | | 1171.88 | 1172.10 | | 1172.16 | | 1172.10 | 1171.38 | |
| DIST. PJESORE E PROJEKTIT | | | 0.2 | 2.5 | | 2.5 | | 0.7 | | |

SEKSIONI NR. : 96
 KUOTA PROJEKTIT : 1166.774
 PROGRESIVA : 2375.000

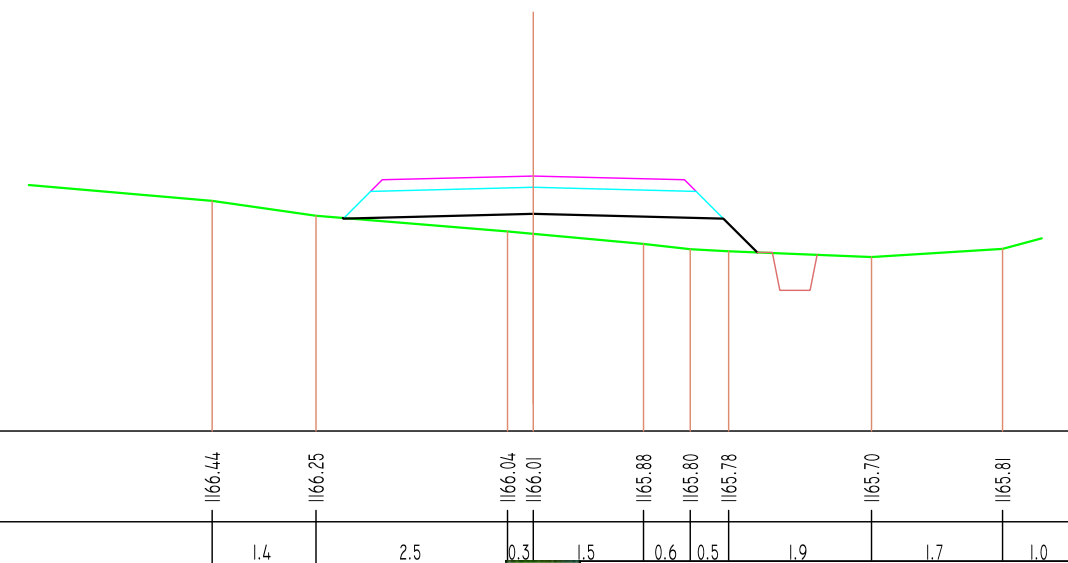

SHKALLA 1:100

KUOTA REF. 1163.401

| | | | | | | | | | | | | | | | | |
|---------------------------|--|--|--|---------|---------|---------|---------|---------|-----|---------|---------|---------|--|---------|--|---------|
| KUOTA E TOKES | | | | 1166.44 | 1166.25 | | 1166.04 | 1166.01 | | 1165.88 | 1165.80 | 1165.78 | | 1165.70 | | 1165.81 |
| DIST. PJESORE E TOKES | | | | 1.4 | 2.5 | | 0.3 | 1.5 | 0.6 | 0.5 | 1.9 | 1.7 | | 1.0 | | |
| KUOTA E PROJEKTIT | | | | | 1166.22 | 1166.21 | | | | | | | | | | |
| DIST. PJESORE E PROJEKTIT | | | | | 2.5 | | | | | | | | | | | |



BASHKIA LIBOHOVE
 OBJEKTI:
 RIPARIMIN DHE ASFALTIM I RRUGËS
 AUTOMOBILIS TIKE FUSHA E ÇAJUPIT – TOPOVË,
 PJESË E UNAZËS SË ZAGORISË L= 8971 ML.
 EMERTIMI I FLETES:
 PROFIL TERTHOR
 HARTOI: SEKTORI SHERBIMIT URBAN
 ARK. NELSON SEJDO
 Data:
 06/2024
 SHK
 1:1000
 Nr. fleta
 24

SEKSIONI NR. : 97
 KUOTA PROJEKTIT : 1163.830
 PROGRESIVA : 2400.000

SEKSIONI NR. : 99
 KUOTA PROJEKTIT : 1157.502
 PROGRESIVA : 2450.000

SHKALLA 1:100

SHKALLA 1:100

KUOTA REF. 1160.809

KUOTA REF. 1154.456

| | | | | | | | | | |
|---------------------------|---------|---------|---------|---------|---------|---------|---------|---------|-----|
| KUOTA E TOKES | 1162.75 | 1163.53 | 1163.68 | 1163.76 | 1163.92 | 1163.71 | 1163.67 | 1163.69 | |
| DIST. PJESORE E TOKES | 5.7 | 3.5 | 0.6 | 0.6 | 2.1 | 0.2 | 1.4 | 1.0 | 0.8 |
| KUOTA E PROJEKTIT | 1162.89 | 1163.27 | 1163.33 | 1163.27 | | | | | |
| DIST. PJESORE E PROJEKTIT | 0.4 | 2.5 | 2.5 | | | | | | |

| | | | | | | | | | |
|---------------------------|---------|---------|---------|---------|---------|---------|---------|---------|---------|
| KUOTA E TOKES | 1155.87 | 1156.12 | 1156.67 | 1156.69 | 1156.71 | 1156.75 | 1157.10 | 1157.88 | 1158.62 |
| DIST. PJESORE E TOKES | 2.8 | 0.9 | 2.6 | 0.9 | 2.1 | 4.2 | | | |
| KUOTA E PROJEKTIT | 1156.26 | 1156.94 | 1157.00 | 1156.94 | | | | | |
| DIST. PJESORE E PROJEKTIT | 0.7 | 2.5 | 2.5 | | | | | | |

SEKSIONI NR. : 98
 KUOTA PROJEKTIT : 1160.881
 PROGRESIVA : 2425.000

SEKSIONI NR. : 100
 KUOTA PROJEKTIT : 1153.971
 PROGRESIVA : 2475.000

SHKALLA 1:100

SHKALLA 1:100

KUOTA REF. 1157.758

KUOTA REF. 1150.468

| | | | | | | | |
|---------------------------|---------|---------|---------|---------|---------|---------|---------|
| KUOTA E TOKES | 1159.53 | 1160.21 | 1160.41 | 1160.42 | 1160.50 | 1160.76 | 1160.77 |
| DIST. PJESORE E TOKES | 6.7 | 2.0 | 0.9 | 1.3 | 1.2 | 0.6 | |
| KUOTA E PROJEKTIT | 1159.92 | 1160.32 | 1160.38 | 1160.32 | | | |
| DIST. PJESORE E PROJEKTIT | 0.4 | 2.5 | 2.5 | | | | |

| | | | | | | |
|---------------------------|---------|---------|---------|---------|---------|---------|
| KUOTA E TOKES | 1152.87 | 1153.18 | 1153.18 | 1153.41 | 1153.46 | 1153.66 |
| DIST. PJESORE E TOKES | 0.8 | 1.2 | 2.5 | 1.6 | | |
| KUOTA E PROJEKTIT | 1153.33 | 1153.41 | | | | |
| DIST. PJESORE E PROJEKTIT | 2.5 | | | | | |



BASHKIA LIBOHOVE

OBJEKTI:
 RIPARIMIN DHE ASFALTIM I RRUGËS
 AUTOMOBILIS TIKE FUSHA E ÇAJUPIT – TOPOVË,
 PJESË E UNAZËS SË ZAGORISË L= 8971 ML.

Data:
 06/2024

EMERTIMI I FLETES:
 PROFIL TERTHOR

SHK
 1:1000

HARTOI: SEKTORI SHERBIMIT URBAN
 ARK. NELSON SEJDO

Nr. fleta
 25

SEKSIONI NR. : 101
 KUOTA PROJEKTIT : 1150.744
 PROGRESIVA : 2500.000

SHKALLA 1:100

KUOTA REF. 1146.628

| | | | | | | | | | | |
|---------------------------|---------|---------|---------|---------|---------|---------|---------|---------|---------|-----|
| KUOTA E TOKES | 1150.87 | 1150.03 | 1149.98 | 1150.00 | 1149.97 | 1149.98 | 1150.01 | 1149.91 | 1149.91 | |
| DIST. PJESORE E TOKES | | 3.1 | 2.1 | 0.4 | 0.7 | 1.1 | 1.4 | | | 8.2 |
| KUOTA E PROJEKTIT | | | 1150.01 | 1150.18 | | 1150.24 | | 1150.18 | 1149.81 | |
| DIST. PJESORE E PROJEKTIT | | | 0.2 | | 2.5 | | 2.5 | 0.4 | | |

SEKSIONI NR. : 103
 KUOTA PROJEKTIT : 1144.988
 PROGRESIVA : 2550.000

SHKALLA 1:100

KUOTA REF. 1141.501

| | | | | | | | | | | |
|---------------------------|---------|---------|---------|---------|---------|---------|---------|---------|---------|---------|
| KUOTA E TOKES | 1144.10 | 1144.03 | 1143.93 | 1143.91 | 1143.92 | 1143.77 | 1143.76 | 1143.73 | | 1144.18 |
| DIST. PJESORE E TOKES | | 2.4 | 0.9 | 0.5 | 0.6 | 1.5 | 0.4 | 1.3 | | 5.1 |
| KUOTA E PROJEKTIT | | | 1143.95 | 1144.42 | | 1144.49 | | 1144.42 | 1143.88 | |
| DIST. PJESORE E PROJEKTIT | | | 0.5 | | 2.5 | | 2.5 | 0.5 | | |

SEKSIONI NR. : 102
 KUOTA PROJEKTIT : 1148.283
 PROGRESIVA : 2525.000

SHKALLA 1:100

KUOTA REF. 1146.119

| | | | | | | | | | | | | |
|---------------------------|--|---------|---------|---------|---------|---------|---------|---------|---------|---------|---------|-----|
| KUOTA E TOKES | | 1149.63 | 1149.59 | 1149.01 | 1147.85 | 1147.85 | 1147.94 | 1147.90 | 1148.04 | 1147.93 | 1148.06 | |
| DIST. PJESORE E TOKES | | | 1.5 | 0.9 | 1.6 | | 2.3 | 0.5 | 0.6 | 0.7 | 1.1 | 3.2 |
| KUOTA E PROJEKTIT | | 1149.71 | 1147.72 | | 1147.78 | | 1147.72 | | | | | |
| DIST. PJESORE E PROJEKTIT | | | 2.0 | | 2.5 | | 2.5 | | | | | |

SEKSIONI NR. : 104
 KUOTA PROJEKTIT : 1141.278
 PROGRESIVA : 2575.000

SHKALLA 1:100

KUOTA REF. 1137.829

| | | | | | | | | | |
|---------------------------|--|---------|---------|--|---------|--|---------|---------|--|
| KUOTA E TOKES | | 1139.12 | 1139.11 | | 1139.65 | | 1140.01 | 1140.09 | |
| DIST. PJESORE E TOKES | | | 4.2 | | | | | | |
| KUOTA E PROJEKTIT | | 1139.12 | 1140.72 | | | | | | |
| DIST. PJESORE E PROJEKTIT | | | 1.6 | | 2.5 | | | | |



BASHKIA LIBOHOVE
 OBJEKTI:
 RIPARIMIN DHE ASFALTIM I RRUGËS
 AUTOMOBILIS TIKE FUSHA E ÇAJUPIT – TOPOVË,
 PJESË E UNAZËS SË ZAGORISË L= 8971 ML.

Data:
06/2024

EMERTIMI I FLETES:
 PROFIL TERTHOR

SHK
1:1000

HARTOI: SEKTORI SHERBIMIT URBAN
 ARK. NELSON SEJDO

Nr. fleta
26

SEKSIONI NR. : 105
 KUOTA PROJEKTIT : 1137.569
 PROGRESIVA : 2600.000

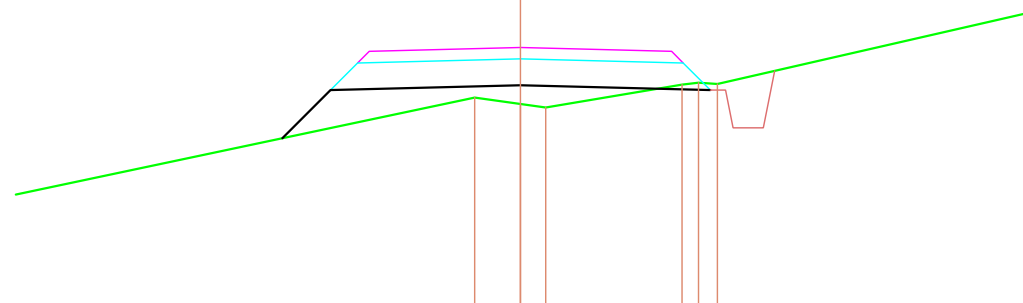

SHKALLA 1:100

KUOTA REF. 1134.066

| | | | | | | | | | | |
|---------------------------|-----|---------|---------|---------|---------|--|---------|---------|---------|-----|
| KUOTA E TOKES | | | 1136.91 | 1136.82 | 1136.77 | | 1137.08 | 1137.10 | 1137.09 | |
| DIST. PJESORE E TOKES | 7.0 | | 0.6 | 0.3 | 1.8 | | 0.2 | 0.2 | | 4.8 |
| KUOTA E PROJEKTIT | | 1136.37 | 1137.01 | | 1137.07 | | 1137.01 | | | |
| DIST. PJESORE E PROJEKTIT | | 0.6 | 2.5 | | 2.5 | | | | | |

SEKSIONI NR. : 107
 KUOTA PROJEKTIT : 1130.150
 PROGRESIVA : 2650.000

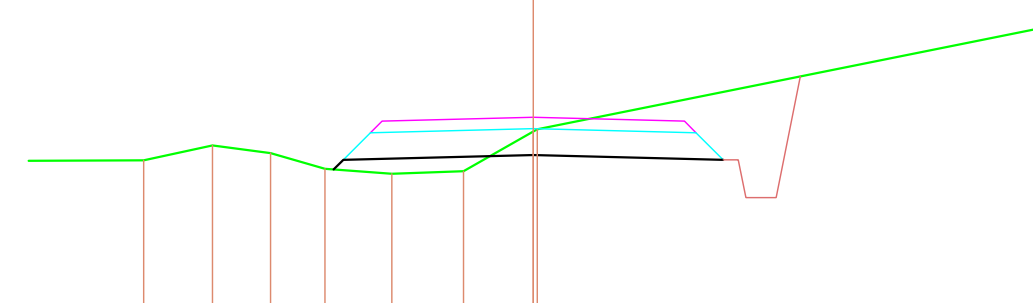

SHKALLA 1:100

KUOTA REF. 1127.571

| | | | | | | | | | | |
|---------------------------|--|--|---------|---------|---------|---------|---------|---------|---------|---------|
| KUOTA E TOKES | | | 1129.58 | 1129.78 | 1129.68 | 1129.47 | 1129.40 | 1129.44 | 1129.96 | 1129.99 |
| DIST. PJESORE E TOKES | | | 0.9 | 0.8 | 0.7 | 0.9 | 0.9 | 0.9 | | 11.3 |
| KUOTA E PROJEKTIT | | | | | | 1129.46 | 1129.59 | | 1129.65 | |
| DIST. PJESORE E PROJEKTIT | | | | | | | 2.5 | | 2.5 | |

SEKSIONI NR. : 106
 KUOTA PROJEKTIT : 1133.860
 PROGRESIVA : 2625.000

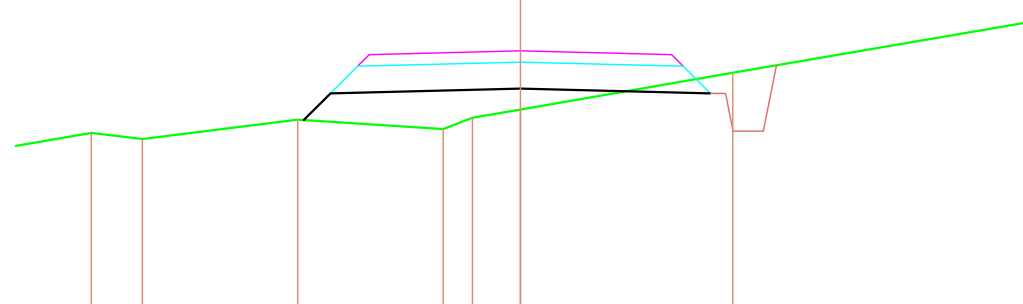

SHKALLA 1:100

KUOTA REF. 1130.367

| | | | | | | | | | |
|---------------------------|--|---------|---------|---------|---------|---------|---------|--|---------|
| KUOTA E TOKES | | 1132.77 | 1132.69 | 1132.95 | 1132.82 | 1132.97 | 1133.08 | | 1133.57 |
| DIST. PJESORE E TOKES | | 0.7 | 2.1 | 1.9 | 0.4 | 0.6 | 2.8 | | 6.3 |
| KUOTA E PROJEKTIT | | | | 1132.94 | 1133.30 | | 1133.36 | | 1133.30 |
| DIST. PJESORE E PROJEKTIT | | | | 0.4 | 2.5 | | 2.5 | | |

SEKSIONI NR. : 108
 KUOTA PROJEKTIT : 1126.441
 PROGRESIVA : 2675.000

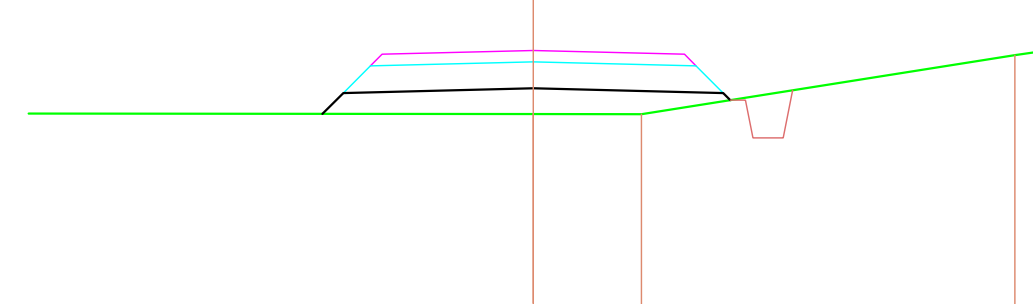

SHKALLA 1:100

KUOTA REF. 1122.944

| | | | | | | |
|---------------------------|--|--|---------|---------|--|---------|
| KUOTA E TOKES | | | 1125.60 | 1125.60 | | 1126.38 |
| DIST. PJESORE E TOKES | | | 6.8 | | | |
| KUOTA E PROJEKTIT | | | 1125.60 | 1125.88 | | |
| DIST. PJESORE E PROJEKTIT | | | 0.3 | 2.5 | | |

| | | | |
|---|--|-------------------------|------------------|
| | | BASHKIA LIBOHOVE | |
| OBJEKTI: RIPARIMIN DHE ASFALTIM I RRUGËS AUTOMOBILIS TIKE FUSHA E ÇAJUPIT – TOPOVË, PJESË E UNAZËS SË ZAGORISË L= 8971 ML. | | | Data: 06/2024 |
| EMERTIMI I FLETES: PROFIL TERTHOR | | | SHK 1:1000 |
| HARTOI: SEKTORI SHERBIMIT URBAN ARK. NELSON SEJDO | | | Nr. fleta 27 |

SEKSIONI NR. : I09
 KUOTA PROJEKTIT : II22.731
 PROGRESIVA : 2700.000

SEKSIONI NR. : III
 KUOTA PROJEKTIT : III17.844
 PROGRESIVA : 2750.000

SHKALLA 1:100

SHKALLA 1:100

KUOTA REF. II21.659

KUOTA REF. III17.077

| | | | | | | | | | | | | | |
|---------------------------|---------|---------|---------|---------|---------|---------|---------|---------|---------|---------|---------|---------|---------|
| KUOTA E TOKES | II20.37 | II20.44 | II20.99 | II21.00 | II20.97 | II21.13 | II21.17 | II21.16 | II21.15 | II22.11 | II22.37 | II22.50 | II22.82 |
| DIST. PJESORE E TOKES | 1.3 | 0.3 | 1.4 | 0.6 | 0.8 | 0.8 | 0.6 | 1.1 | 2.0 | 0.6 | 0.6 | 0.5 | 2.7 |
| KUOTA E PROJEKTIT | | | II21.00 | II22.17 | II22.23 | | | | II22.17 | II21.93 | | | |
| DIST. PJESORE E PROJEKTIT | | | 1.2 | 2.5 | 2.5 | | | 0.2 | | | | | |

| | | | | | | | | | |
|---------------------------|----------|----------|----------|----------|----------|----------|----------|----------|-----|
| KUOTA E TOKES | III16.41 | III16.37 | III16.34 | III16.33 | III16.37 | III16.44 | III16.78 | III16.90 | |
| DIST. PJESORE E TOKES | 3.8 | 0.3 | 0.3 | 0.8 | 0.7 | 1.3 | 0.2 | 0.2 | 7.0 |
| KUOTA E PROJEKTIT | III16.36 | III17.28 | III17.34 | III17.28 | III17.34 | III17.28 | | | |
| DIST. PJESORE E PROJEKTIT | 0.9 | 2.5 | 2.5 | | | | | | |

SEKSIONI NR. : I10
 KUOTA PROJEKTIT : III19.604
 PROGRESIVA : 2725.000

SEKSIONI NR. : II2
 KUOTA PROJEKTIT : III16.126
 PROGRESIVA : 2775.000

SHKALLA 1:100

SHKALLA 1:100

KUOTA REF. III19.146

KUOTA REF. III14.832

| | | | | | | | | | |
|---------------------------|----------|----------|----------|----------|----------|----------|----------|----------|-----|
| KUOTA E TOKES | III17.86 | III18.76 | III18.7 | III18.73 | III18.72 | III18.71 | III19.45 | III20.24 | |
| DIST. PJESORE E TOKES | 2.7 | 2.2 | 1.9 | 0.5 | 0.5 | 0.5 | 2.0 | 1.4 | 3.0 |
| KUOTA E PROJEKTIT | | III18.76 | III19.04 | III19.10 | III19.04 | | | | |
| DIST. PJESORE E PROJEKTIT | | 0.3 | 2.5 | 2.5 | | | | | |

| | | | | | | | | |
|---------------------------|----------|----------|----------|----------|----------|----------|----------|----------|
| KUOTA E TOKES | III14.74 | III14.76 | III14.76 | III14.66 | III14.80 | III14.80 | III16.21 | III16.26 |
| DIST. PJESORE E TOKES | 2.3 | 1.4 | 0.9 | 1.2 | 8.3 | | | |
| KUOTA E PROJEKTIT | III14.71 | III15.56 | | | | | | |
| DIST. PJESORE E PROJEKTIT | 0.9 | 2.5 | | | | | | |



BASHKIA LIBOHOVE

OBJEKTI:
 RIPARIMIN DHE ASFALTIM I RRUGËS
 AUTOMOBILIS TIKE FUSHA E ÇAJUPIT – TOPOVË,
 PJESË E UNAZËS SË ZAGORISË L= 8971 ML.

Data:

06/2024

EMERTIMI I FLETES:
 PROFIL TERTHOR

SHK
 1:1000

HARTOI: SEKTORI SHERBIMIT URBAN
 ARK. NELSON SEJDO

Nr. fleta
 28

SEKSIONI NR. : II3
 KUOTA PROJEKTIT : III2.751
 PROGRESIVA : 2800.000

SEKSIONI NR. : II5
 KUOTA PROJEKTIT : II05.701
 PROGRESIVA : 2850.000

SHKALLA 1:100

SHKALLA 1:100

KUOTA REF. III2.952

KUOTA REF. II06.011

| | | | | | | | | | | | |
|---------------------------|-----|---------|---------|---------|---------|---------|---------|---------|---------|---------|--|
| KUOTA E TOKES | | III0.99 | III1.78 | III1.82 | III1.00 | III2.21 | III2.42 | III2.44 | III2.53 | III3.30 | |
| DIST. PJESORE E TOKES | 3.6 | 1.8 | 0.3 | 1.5 | 0.7 | 0.7 | 0.4 | 1.5 | | 4.2 | |
| KUOTA E PROJEKTIT | | III1.57 | III2.19 | | III2.25 | | | III2.19 | | | |
| DIST. PJESORE E PROJEKTIT | | 0.6 | 2.5 | | 2.5 | | | | | | |

| | | | | | | | | | |
|---------------------------|--|---------|---------|---------|---------|---------|---------|---------|-----|
| KUOTA E TOKES | | II02.19 | II04.16 | II04.24 | II04.28 | II04.50 | II05.21 | II07.87 | |
| DIST. PJESORE E TOKES | | 2.0 | 1.3 | 1.3 | 1.2 | 0.9 | 3.4 | | 4.8 |
| KUOTA E PROJEKTIT | | | II04.24 | II05.14 | | II05.20 | | II05.14 | |
| DIST. PJESORE E PROJEKTIT | | | 0.9 | 2.5 | | 2.5 | | | |

SEKSIONI NR. : II4
 KUOTA PROJEKTIT : II09.226
 PROGRESIVA : 2825.000

SEKSIONI NR. : II6
 KUOTA PROJEKTIT : II02.180
 PROGRESIVA : 2875.000

SHKALLA 1:100

SHKALLA 1:100

KUOTA REF. II09.693

KUOTA REF. II00.833

| | | | | | | | | | |
|---------------------------|-----|---------|---------|---------|---------|---------|---------|---------|--|
| KUOTA E TOKES | | II07.92 | II07.99 | II08.16 | II08.26 | II08.48 | II08.57 | II11.06 | |
| DIST. PJESORE E TOKES | 4.2 | 1.0 | 0.9 | 0.8 | 0.8 | 2.2 | 1.5 | | |
| KUOTA E PROJEKTIT | | II07.94 | II08.66 | | II08.73 | | II08.66 | | |
| DIST. PJESORE E PROJEKTIT | | 0.7 | 2.5 | | 2.5 | | | | |

| | | | | | | | | | |
|---------------------------|--|---------|---------|---------|---------|---------|---------|---------|--|
| KUOTA E TOKES | | II01.15 | II01.16 | II01.13 | II01.19 | II01.27 | II01.28 | II02.39 | |
| DIST. PJESORE E TOKES | | 3.4 | 1.2 | 1.0 | 0.8 | 1.1 | | 2.4 | |
| KUOTA E PROJEKTIT | | | II01.16 | II01.62 | | | | | |
| DIST. PJESORE E PROJEKTIT | | | 0.5 | 2.5 | | | | | |



BASHKIA LIBOHOVE

OBJEKTI:
 RIPARIMIN DHE ASFALTIM I RRUGËS
 AUTOMOBILIS TIKE FUSHA E ÇAJUPIT – TOPOVË,
 PJESË E UNAZËS SË ZAGORISË L= 8971 ML.

Data:
 06/2024

EMERTIMI I FLETES:

PROFIL TERTHOR

SHK
 1:1000

HARTOI: SEKTORI SHERBIMIT URBAN
 ARK. NELSON SEJDO

Nr. fleta
 29

SEKSIONI NR. : 117
 KUOTA PROJEKTIT : 1099.598
 PROGRESIVA : 2900.000

SEKSIONI NR. : 119
 KUOTA PROJEKTIT : 1096.20
 PROGRESIVA : 2950.000

SHKALLA 1:100

SHKALLA 1:100

KUOTA REF. 1097.320

KUOTA REF. 1093.932

| | | | | | | | |
|---------------------------|--------------------|--------------------|-------------------------------|--------------------|--------|-----|-----|
| KUOTA E TOKES | 1098.27 1098.47 | 1098.68 1098.88 | 1098.66 1098.67 1098.81 | 1099.92 1000.08 | 671011 | | |
| DIST. PJESORE E TOKES | 0.2 | 2.4 | 2.0 | 1.5 | 0.4 | 2.3 | 4.1 |
| KUOTA E PROJEKTIT | | 1098.65 1098.83 | 1098.90 | 1098.83 | | | |
| DIST. PJESORE E PROJEKTIT | | 0.2 | 2.5 | 2.5 | | | |

| | | | | | | | |
|---------------------------|--------------------|---------|---------|--------------------|--------------------|---------|-----|
| KUOTA E TOKES | 1095.32 | 1095.31 | 1095.51 | 1095.58 1095.66 | 1097.33 1097.68 | 1099.35 | |
| DIST. PJESORE E TOKES | 1.1 | 1.8 | 0.5 | 0.5 | 2.8 | 0.4 | 1.7 |
| KUOTA E PROJEKTIT | 1095.31 1095.56 | | 1095.62 | | 1095.56 | | |
| DIST. PJESORE E PROJEKTIT | 0.2 | 2.5 | 2.5 | | | | |

SEKSIONI NR. : 118
 KUOTA PROJEKTIT : 1097.694
 PROGRESIVA : 2925.000

SEKSIONI NR. : 120
 KUOTA PROJEKTIT : 1094.707
 PROGRESIVA : 2975.000

SHKALLA 1:100

SHKALLA 1:100

KUOTA REF. 1095.061

KUOTA REF. 1092.843

| | | | | | | | |
|---------------------------|--------------------|---------|--------------------|---------|---------|---------|---------|
| KUOTA E TOKES | 1096.92 | 1096.90 | 1096.95 1096.99 | 1097.06 | 1097.17 | 1099.80 | 1102.67 |
| DIST. PJESORE E TOKES | 1.8 | 0.4 | 0.2 | 0.7 | 1.0 | 2.4 | 3.0 |
| KUOTA E PROJEKTIT | 1096.92 1097.15 | | | 1097.19 | 1097.15 | | |
| DIST. PJESORE E PROJEKTIT | 0.2 | 2.5 | | 2.5 | | | |

| | | | | |
|---------------------------|--------------------|---------|--|---------|
| KUOTA E TOKES | 1092.48 | 1094.14 | 1094.12 1094.13 1094.14 1094.24 | 1098.98 |
| DIST. PJESORE E TOKES | 1.5 | 2.7 | 0.2 0.2 | 5.5 |
| KUOTA E PROJEKTIT | 1094.14 1094.14 | | | |
| DIST. PJESORE E PROJEKTIT | 2.5 | | | |



BASHKIA LIBOHOVE

OBJEKTI:
 RIPARIMIN DHE ASFALTIM I RRUGËS
 AUTOMOBILIS TIKE FUSHA E ÇAJUPIT – TOPOVË,
 PJESË E UNAZËS SË ZAGORISË L= 8971 ML.

Data:

06/2024

EMERTIMI I FLETES:

PROFIL TERTHOR

SHK
 1:1000

HARTOI: SEKTORI SHERBIMIT URBAN
 ARK. NELSON SEJDO

Nr. fleta

30

SEKSIONI NR. : 121
 KUOTA PROJEKTIT : 1094.227
 PROGRESIVA : 3000.000

SHKALLA 1:100

KUOTA REF. 1091.354

| | | | | | | | | | | | | |
|---------------------------|-----|---------|---------|---------|---------|---------|---------|---------|---------|---------|---------|---------|
| KUOTA E TOKES | | 1093.48 | 1093.73 | 1093.71 | 1093.75 | 1093.75 | 1093.77 | 1093.91 | 1094.43 | 1097.07 | 1097.23 | 1098.59 |
| DIST. PJESORE E TOKES | 3.9 | 0.7 | 0.5 | 0.5 | 1.2 | 1.1 | 0.4 | 2.8 | 0.2 | 1.4 | | |
| KUOTA E PROJEKTIT | | 1093.62 | 1093.66 | | 1093.73 | | 1093.66 | | | | | |
| DIST. PJESORE E PROJEKTIT | | | 2.5 | | 2.5 | | | | | | | |

SEKSIONI NR. : 123
 KUOTA PROJEKTIT : 1090.839
 PROGRESIVA : 3050.000

SHKALLA 1:100

KUOTA REF. 1084.702

| | | | | | | | | | | | |
|---------------------------|--|---------|---------|---------|---------|---------|---------|---------|---------|---------|---------|
| KUOTA E TOKES | | 1088.87 | 1089.96 | 1089.92 | 1090.10 | 1090.11 | 1090.13 | 1090.27 | 1090.88 | 1091.93 | 1094.25 |
| DIST. PJESORE E TOKES | | 2.1 | 1.4 | 1.7 | 0.3 | 0.3 | 0.2 | 0.9 | 0.9 | 4.2 | |
| KUOTA E PROJEKTIT | | | | 1089.93 | 1090.28 | | 1090.34 | | 1090.28 | | |
| DIST. PJESORE E PROJEKTIT | | | | 0.3 | 2.5 | | 2.5 | | | | |

SEKSIONI NR. : 122
 KUOTA PROJEKTIT : 1093.040
 PROGRESIVA : 3025.000

SHKALLA 1:100

KUOTA REF. 1088.343

| | | | | | | | | |
|---------------------------|--|---------|---------|---------|---------|---------|---------|---------|
| KUOTA E TOKES | | 1092.24 | 1092.35 | 1092.36 | 1092.46 | 1092.46 | 1094.13 | 1095.96 |
| DIST. PJESORE E TOKES | | 1.0 | 1.2 | 1.2 | 1.9 | 3.0 | | |
| KUOTA E PROJEKTIT | | 1092.32 | 1092.48 | | 1092.54 | 1092.48 | | |
| DIST. PJESORE E PROJEKTIT | | | 2.5 | | 2.5 | | | |

SEKSIONI NR. : 124
 KUOTA PROJEKTIT : 1088.761
 PROGRESIVA : 3075.000

SHKALLA 1:100

KUOTA REF. 1081.708

| | | | | | | | | | | | |
|---------------------------|--|---------|---------|---------|---------|---------|---------|---------|---------|---------|---------|
| KUOTA E TOKES | | 1086.41 | 1086.88 | 1087.69 | 1087.77 | 1087.81 | 1088.03 | 1088.16 | 1088.19 | 1090.53 | 1090.64 |
| DIST. PJESORE E TOKES | | 0.9 | 1.3 | 0.8 | 0.7 | 1.1 | 1.1 | 0.2 | 4.2 | 0.2 | |
| KUOTA E PROJEKTIT | | | | 1087.77 | 1088.20 | | | | | | |
| DIST. PJESORE E PROJEKTIT | | | | 0.4 | 2.5 | | | | | | |



BASHKIA LIBOHOVE

OBJEKTI:
 RIPARIMIN DHE ASFALTIM I RRUGËS
 AUTOMOBILIS TIKE FUSHA E ÇAJUPIT - TOPOVË,
 PJESË E UNAZËS SË ZAGORISË L= 8971 ML.

Data:
 06/2024

EMERTIMI I FLETES:
 PROFIL TERTHOR

SHK
 1:1000

HARTOI: SEKTORI SHERBIMIT URBAN
 ARK. NELSON SEJDO

Nr. fleta
 31

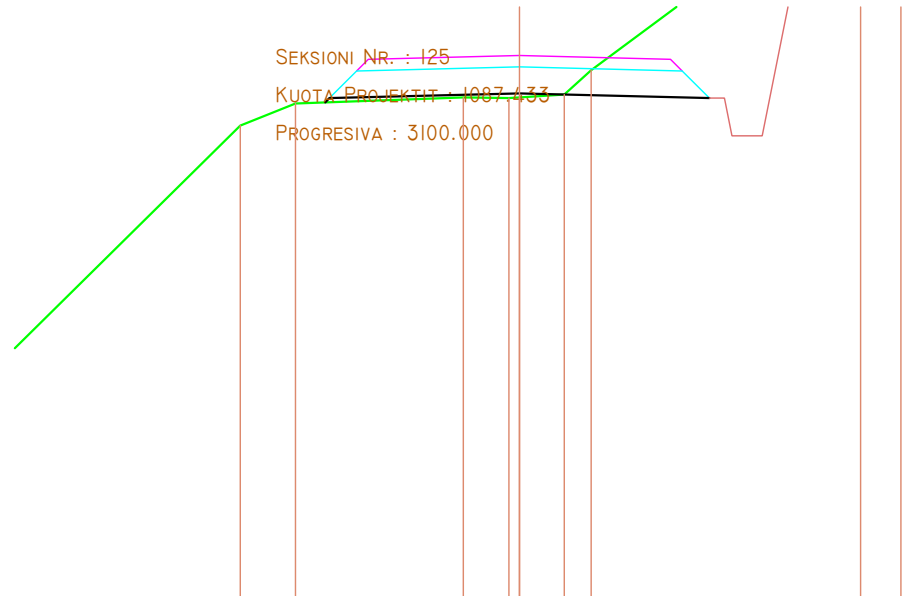

SHKALLA 1:100

KUOTA REF. 1080.223

| | | | | | | | | | |
|---------------------------|---------|---------|---------|---------|---------|---------|---------|---------|---------|
| KUOTA E TOKES | 1086.51 | 1086.80 | 1086.88 | 1086.87 | 1086.88 | 1086.92 | 1087.24 | 1089.88 | 1090.26 |
| DIST. PJESORE E TOKES | 0.7 | 2.2 | 0.6 | 0.6 | 0.4 | 3.6 | 0.5 | 1.8 | |
| KUOTA E PROJEKTIT | 1086.81 | 1086.87 | 1086.93 | 1086.87 | | | | | |
| DIST. PJESORE E PROJEKTIT | | 2.5 | 2.5 | | | | | | |

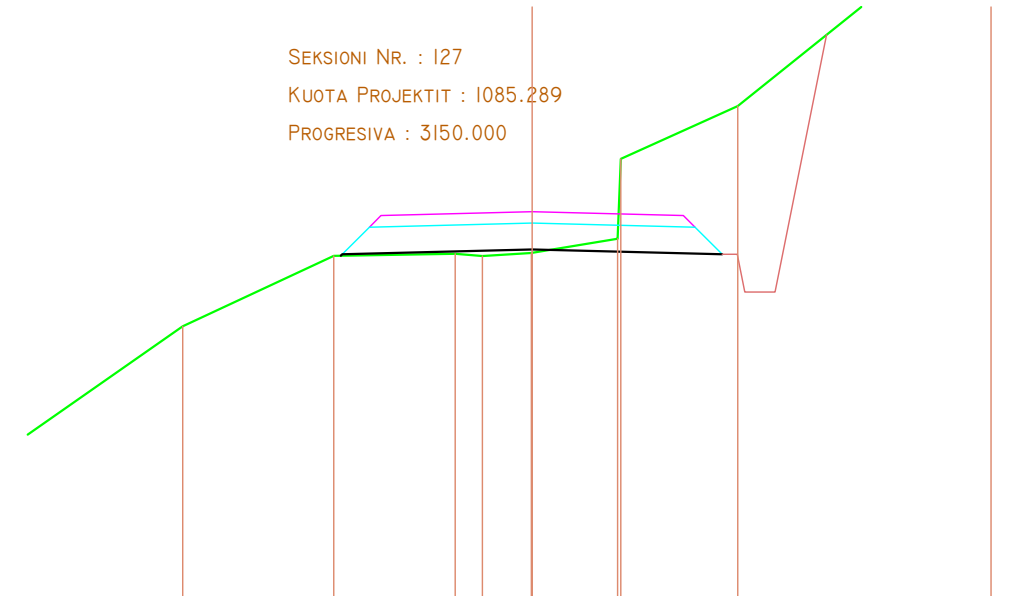

SHKALLA 1:100

KUOTA REF. 1080.145

| | | | | | | | | | | |
|---------------------------|---------|---------|---------|---------|---------|---------|---------|---------|---------|---------|
| KUOTA E TOKES | 1083.77 | 1084.71 | 1084.73 | 1084.70 | 1084.74 | 1084.74 | 1084.93 | 1085.99 | 1086.69 | 1089.37 |
| DIST. PJESORE E TOKES | 2.0 | 1.6 | 0.4 | 0.6 | 1.1 | 1.5 | 3.4 | 1.4 | | |
| KUOTA E PROJEKTIT | 1084.71 | 1084.73 | 1084.79 | 1084.75 | | | | | | |
| DIST. PJESORE E PROJEKTIT | | 2.5 | 2.5 | | | | | | | |

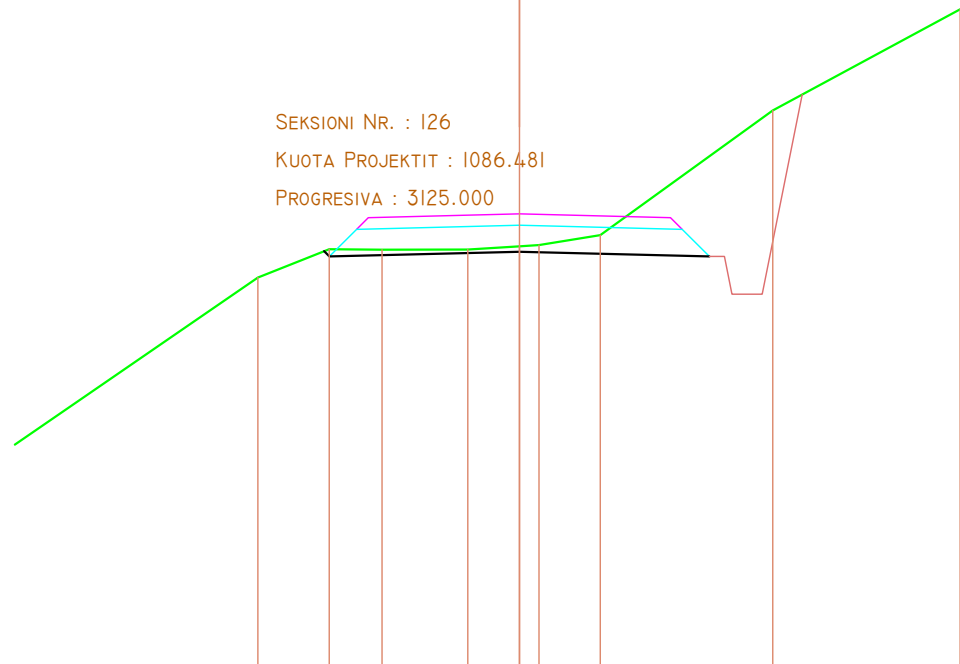

SHKALLA 1:100

KUOTA REF. 1080.499

| | | | | | | | | | |
|---------------------------|---------|---------|---------|---------|---------|---------|---------|---------|---------|
| KUOTA E TOKES | 1085.64 | 1086.01 | 1086.01 | 1086.01 | 1086.05 | 1086.07 | 1086.20 | 1087.85 | 1089.19 |
| DIST. PJESORE E TOKES | 0.9 | 0.7 | 1.1 | 0.7 | 0.3 | 0.8 | 2.3 | 2.5 | |
| KUOTA E PROJEKTIT | 1085.99 | 1085.92 | 1085.98 | 1085.92 | | | | | |
| DIST. PJESORE E PROJEKTIT | | 2.5 | 2.5 | | | | | | |

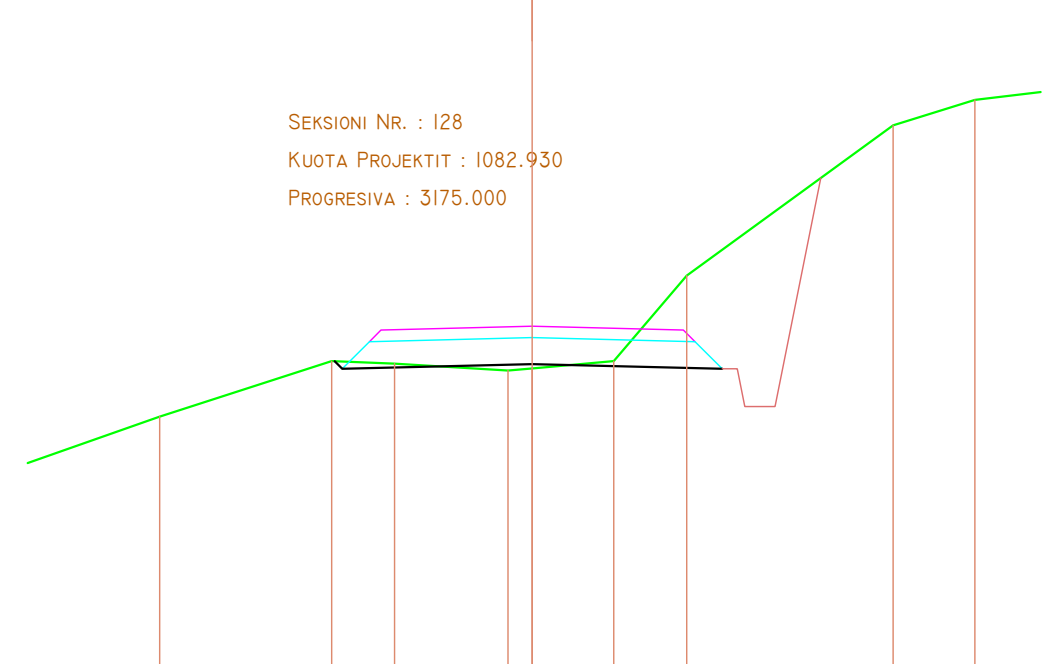

SHKALLA 1:100

KUOTA REF. 1078.434

| | | | | | | | | | |
|---------------------------|---------|---------|---------|---------|---------|---------|---------|---------|---------|
| KUOTA E TOKES | 1081.74 | 1082.47 | 1082.43 | 1082.34 | 1082.37 | 1082.47 | 1083.60 | 1085.59 | 1085.92 |
| DIST. PJESORE E TOKES | 2.3 | 0.8 | 1.5 | | | | | | |
| KUOTA E PROJEKTIT | 1082.47 | 1082.37 | | | | | | | |
| DIST. PJESORE E PROJEKTIT | | 2.5 | | | | | | | |

| | | | |
|--|--|--|------------------|
| BASHKIA LIBOHOVE | |  OBJEKTI: RIPARIMIN DHE ASFALTIM I RRUGËS AUTOMOBILIS TIKE FUSHA E ÇAJUPIT – TOPOVË, PJESË E UNAZËS SË ZAGORISË L= 8971 ML. | Data: 06/2024 |
| EMERTIMI I FLETES: PROFIL TERTHOR | | | SHK 1:1000 |
| HARTOI: SEKTORI SHERBIMIT URBAN ARK. NELSON SEJDO | | Nr. fleta 32 | |

SEKSIONI NR. : 129
 KUOTA PROJEKTIT : 1079.963
 PROGRESIVA : 3200.000

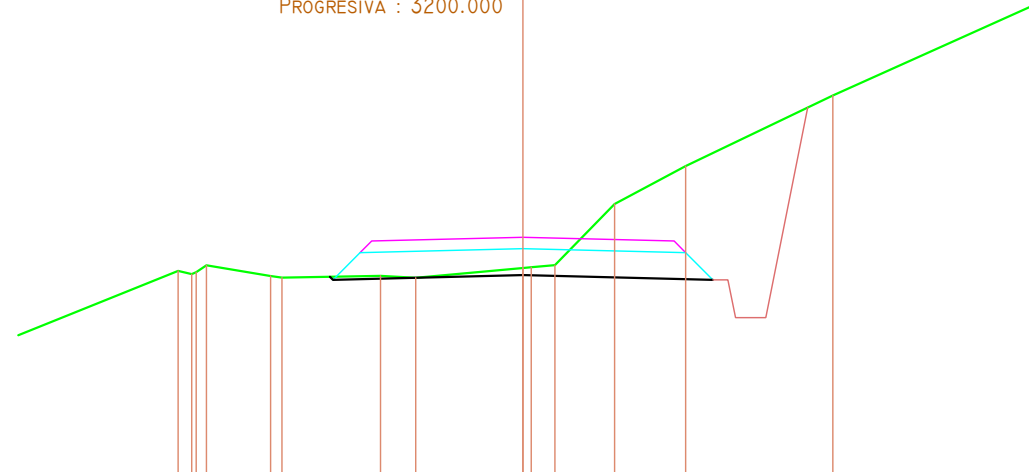

SHKALLA 1:100

KUOTA REF. 1076.823

| | | | | | | | | | | | | | | |
|---------------------------|---------|---------|---------|---------|---------|---------|---------|---------|---------|---------|---------|---------|---------|---------|
| KUOTA E TOKES | 1079.52 | 1079.48 | 1079.50 | 1079.59 | 1079.45 | 1079.43 | 1079.45 | 1079.43 | 1079.56 | 1079.57 | 1079.59 | 1080.40 | 1080.90 | 1081.84 |
| DIST. PJESORE E TOKES | 0.2 | 0.8 | | 1.3 | 0.5 | 1.4 | | 0.3 | 0.8 | 0.9 | 1.9 | | 4.4 | |
| KUOTA E PROJEKTIT | | | | 1079.44 | 1079.40 | | | 1079.46 | | | 1079.40 | | | |
| DIST. PJESORE E PROJEKTIT | | | | 2.5 | | | 2.5 | | | | | | | |

SEKSIONI NR. : 131
 KUOTA PROJEKTIT : 1076.044
 PROGRESIVA : 3250.000

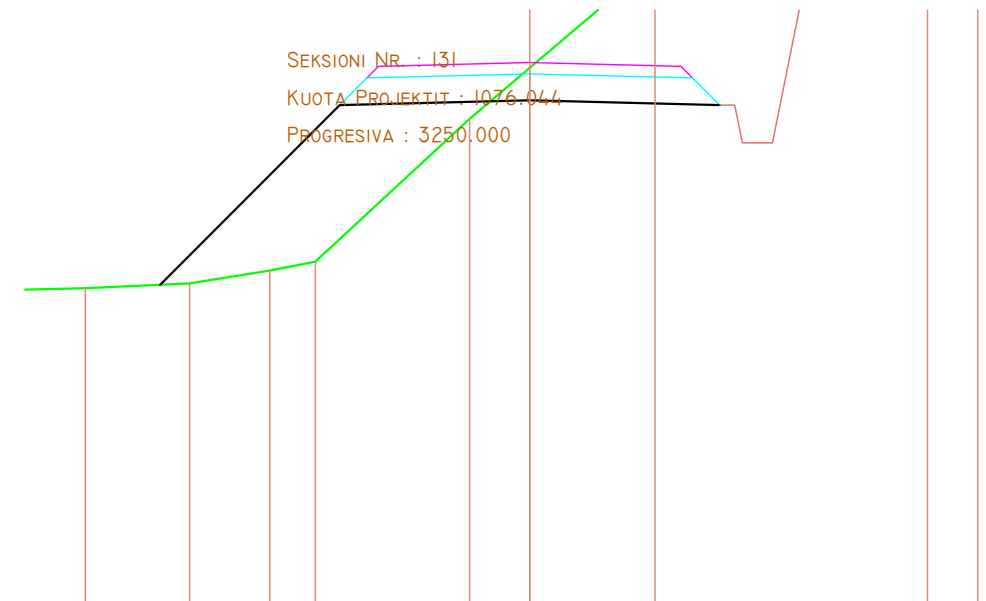

SHKALLA 1:100

KUOTA REF. 1068.887

| | | | | | | | | | |
|---------------------------|---------|---------|---------|---------|---------|---------|---------|---------|---------|
| KUOTA E TOKES | 1073.06 | 1073.12 | 1073.29 | 1073.41 | 1075.30 | 1075.97 | 1077.38 | 1078.93 | 1079.21 |
| DIST. PJESORE E TOKES | 1.4 | 1.1 | 0.6 | 2.0 | 0.8 | 1.7 | 3.6 | 0.7 | |
| KUOTA E PROJEKTIT | 1073.10 | | 1075.48 | | 1075.54 | | 1075.48 | | |
| DIST. PJESORE E PROJEKTIT | | 2.4 | 2.5 | | 2.5 | | | | |

SEKSIONI NR. : 130
 KUOTA PROJEKTIT : 1077.186
 PROGRESIVA : 3225.000

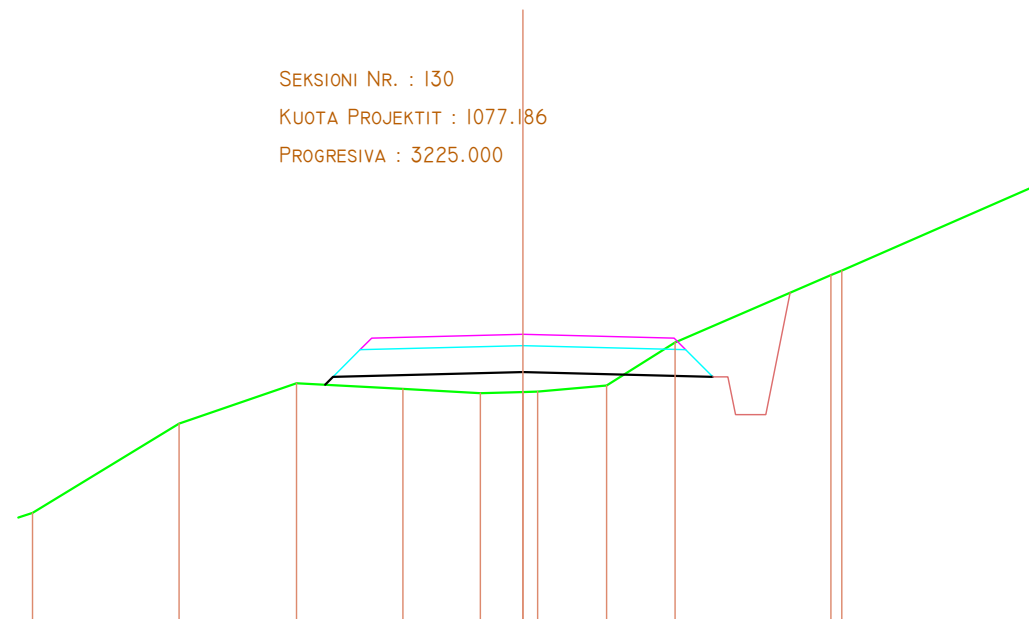

SHKALLA 1:100

KUOTA REF. 1073.365

| | | | | | | | | | | | |
|---------------------------|---------|---------|---------|---------|---------|---------|---------|---------|---------|---------|---------|
| KUOTA E TOKES | 1074.82 | 1076.01 | 1076.54 | 1076.46 | 1076.41 | 1076.42 | 1076.43 | 1076.51 | 1077.08 | 1077.97 | 1078.03 |
| DIST. PJESORE E TOKES | 1.9 | 1.6 | 1.4 | 1.0 | 0.6 | 0.2 | 0.9 | 0.9 | 2.1 | | 4.4 |
| KUOTA E PROJEKTIT | | | 1076.52 | 1076.62 | | 1076.69 | | 1076.62 | | | |
| DIST. PJESORE E PROJEKTIT | | | 2.5 | | | 2.5 | | | | | |

SEKSIONI NR. : 132
 KUOTA PROJEKTIT : 1073.475
 PROGRESIVA : 3275.000

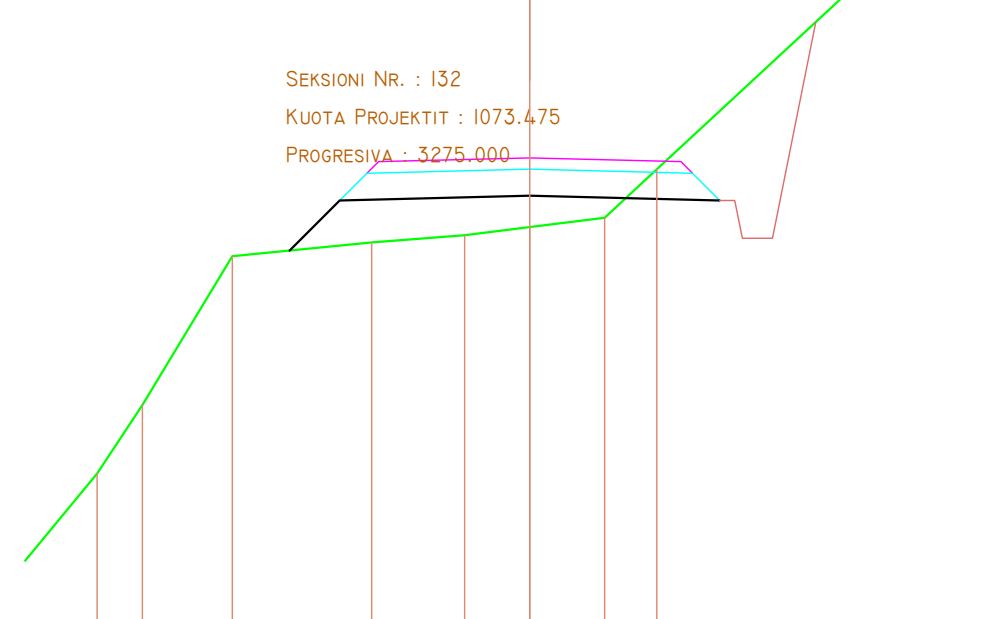

SHKALLA 1:100

KUOTA REF. 1067.320

| | | | | | | | | |
|---------------------------|---------|---------|---------|---------|---------|---------|---------|---------|
| KUOTA E TOKES | 1069.30 | 1070.21 | 1072.17 | 1072.36 | 1072.45 | 1072.56 | 1072.68 | 1073.32 |
| DIST. PJESORE E TOKES | 1.1 | 0.6 | 1.2 | 1.8 | 1.2 | 0.9 | | |
| KUOTA E PROJEKTIT | | | 1072.25 | 1072.91 | | | | |
| DIST. PJESORE E PROJEKTIT | | | 0.7 | 2.5 | | | | |



BASHKIA LIBOHOVE

OBJEKTI:
 RIPARIMIN DHE ASFALTIM I RRUGËS
 AUTOMOBILIS TIKE FUSHA E ÇAJUPIT – TOPOVË,
 PJESË E UNAZËS SË ZAGORISË L= 8971 ML.

Data:
 06/2024

EMERTIMI I FLETES:
 PROFIL TERTHOR

SHK
 1:1000

HARTOI: SEKTORI SHERBIMIT URBAN
 ARK. NELSON SEJDO

Nr. fleta
 33

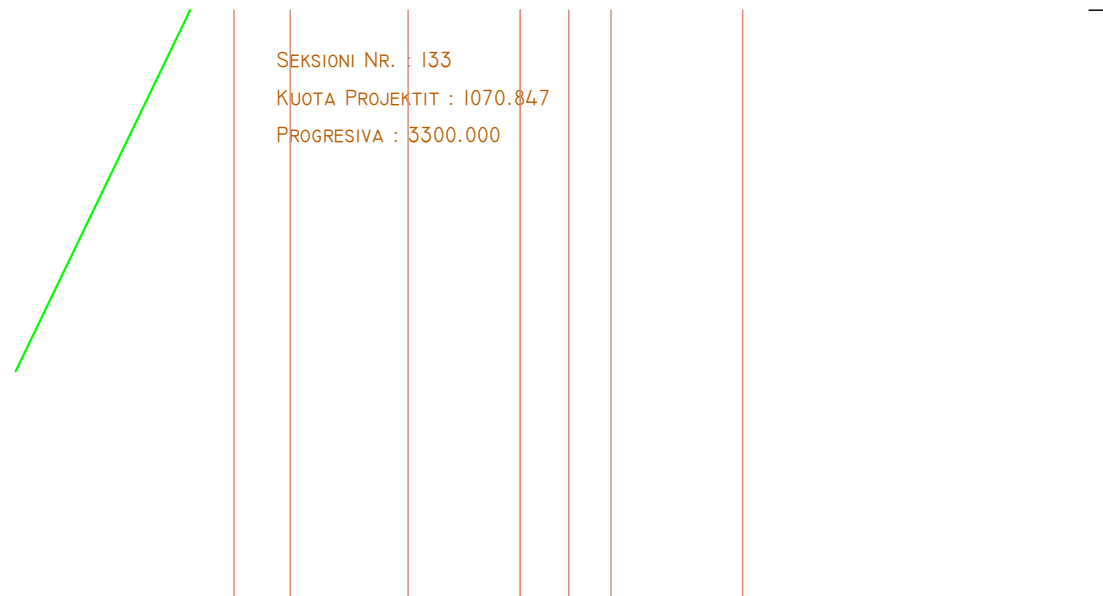

| | | | | | | | |
|---------------------------|---------|---------|---------|---------|---------|---------|---------|
| KUOTA E TOKES | 1069.51 | 1069.72 | 1069.86 | 1070.16 | 1070.29 | 1070.34 | 1071.83 |
| DIST. PJESORE E TOKES | 0.7 | 1.6 | 1.5 | 0.6 | 0.6 | 1.7 | 4.9 |
| KUOTA E PROJEKTIT | 1069.70 | 1070.28 | | 1070.35 | | | 1070.28 |
| DIST. PJESORE E PROJEKTIT | 0.6 | 2.5 | | 2.5 | | | |

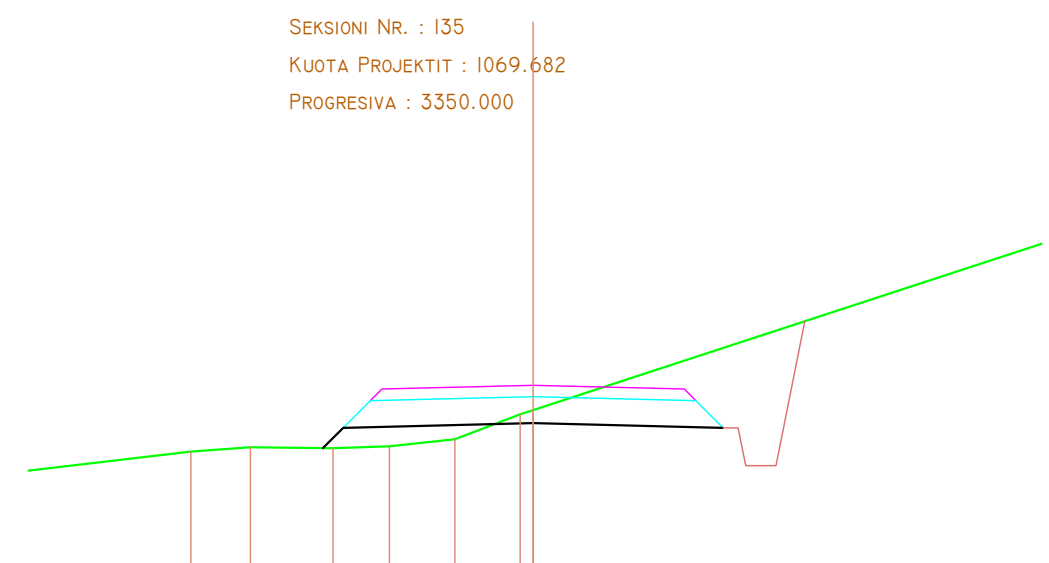

| | | | | | | | |
|---------------------------|---------|---------|---------|---------|---------|---------|---------|
| KUOTA E TOKES | 1066.81 | 1066.86 | 1066.85 | 1066.88 | 1066.97 | 1069.30 | 1069.35 |
| DIST. PJESORE E TOKES | 0.8 | 1.1 | 0.7 | 0.9 | 0.9 | 0.2 | 6.8 |
| KUOTA E PROJEKTIT | | | 1066.85 | 1069.12 | | 1069.18 | 1069.12 |
| DIST. PJESORE E PROJEKTIT | | | 0.3 | 2.5 | | 2.5 | |

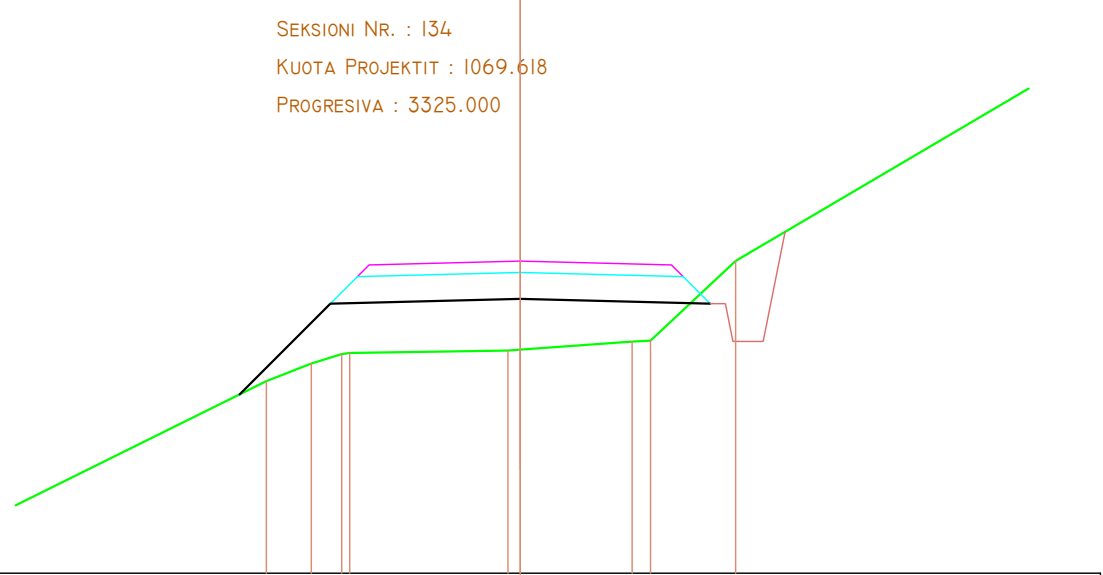

| | | | | | | | | | |
|---------------------------|---------|---------|---------|---------|---------|---------|---------|---------|---------|
| KUOTA E TOKES | 1068.03 | 1068.26 | 1068.39 | 1068.40 | 1068.44 | 1068.45 | 1068.55 | 1068.57 | 1069.62 |
| DIST. PJESORE E TOKES | 4.2 | 0.6 | 0.4 | 2.1 | 0.2 | 1.5 | 0.2 | 1.1 | 4.0 |
| KUOTA E PROJEKTIT | 1067.86 | 1069.06 | | | 1069.12 | | | | 1069.06 |
| DIST. PJESORE E PROJEKTIT | 1.2 | 2.5 | | 2.5 | | | | | |

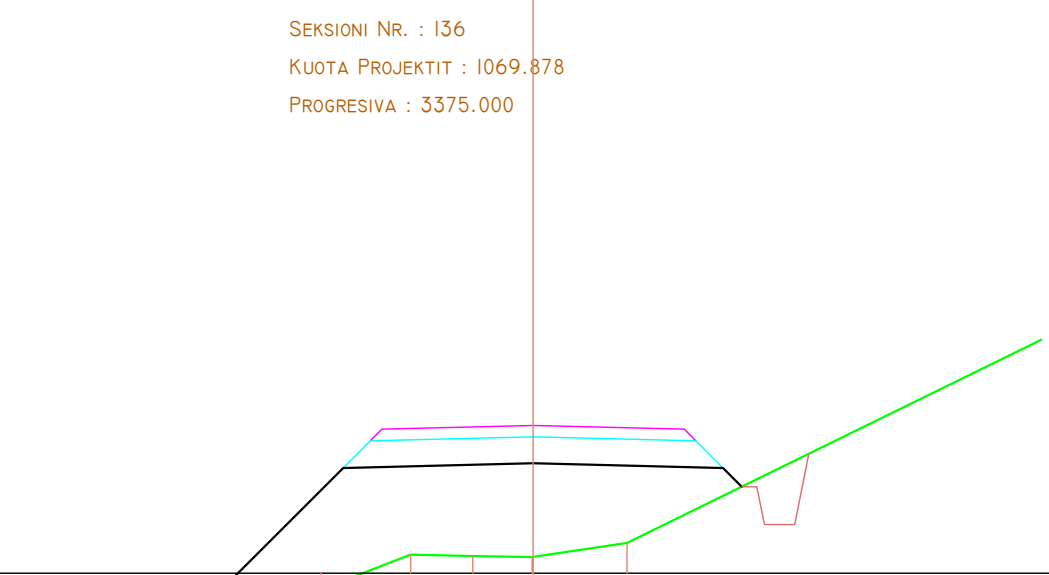

| | | | | | | |
|---------------------------|---------|---------|---------|---------|---------|---------|
| KUOTA E TOKES | 1067.71 | 1068.17 | 1068.15 | 1068.14 | 1068.14 | 1068.32 |
| DIST. PJESORE E TOKES | | 1.2 | 0.8 | 0.8 | | |
| KUOTA E PROJEKTIT | 1067.57 | 1069.32 | | | | |
| DIST. PJESORE E PROJEKTIT | 1.7 | 2.5 | | | | |

BASHKIA LIBOHOVE

OBJEKTI:
 RIPARIMIN DHE ASFALTIM I RRUGËS
 AUTOMOBILIS TIKE FUSHA E ÇAJUPIT – TOPOVË,
 PJESE E UNAZËS SË ZAGORISË L= 8971 ML.

EMERTIMI I FLETES:
 PROFIL TERTHOR

HARTOI: SEKTORI SHERBIMIT URBAN
 ARK. NELSON SEJDO

Data:
 06/2024

SHK
 1:1000

Nr. fleta
 34

SEKSIONI NR. : 137
 KUOTA PROJEKTIT : 1070.073
 PROGRESIVA : 3400.000

SHKALLA 1:100

KUOTA REF. 1067.858

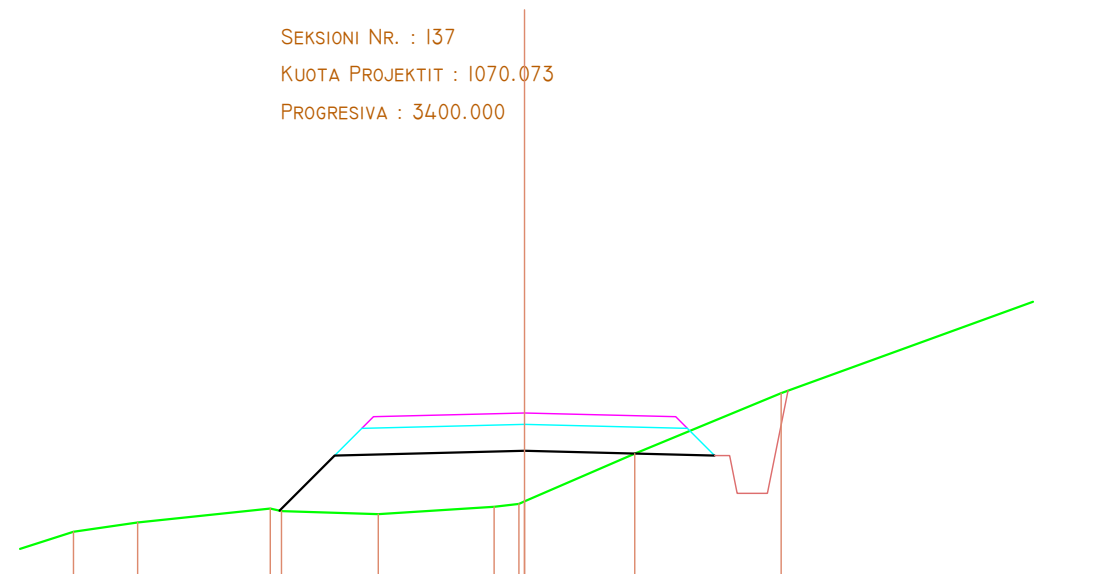

| | | | | | | | | | | |
|---------------------------|---------|---------|---------|---------|---------|---------|---------|---------|---------|---------|
| KUOTA E TOKES | 1068.50 | 1068.62 | 1068.81 | 1068.78 | 1068.73 | 1068.83 | 1068.87 | 1068.90 | 1069.53 | 1070.34 |
| DIST. PJESORE E TOKES | 0.8 | 1.8 | 1.3 | 1.5 | 0.3 | 1.5 | 1.9 | 5.2 | | |
| KUOTA E PROJEKTIT | | | 1068.78 | 1069.51 | | 1069.57 | | 1069.51 | | |
| DIST. PJESORE E PROJEKTIT | | | 0.7 | 2.5 | | 2.5 | | | | |

SEKSIONI NR. : 139
 KUOTA PROJEKTIT : 1070.464
 PROGRESIVA : 3450.000

SHKALLA 1:100

KUOTA REF. 1065.881

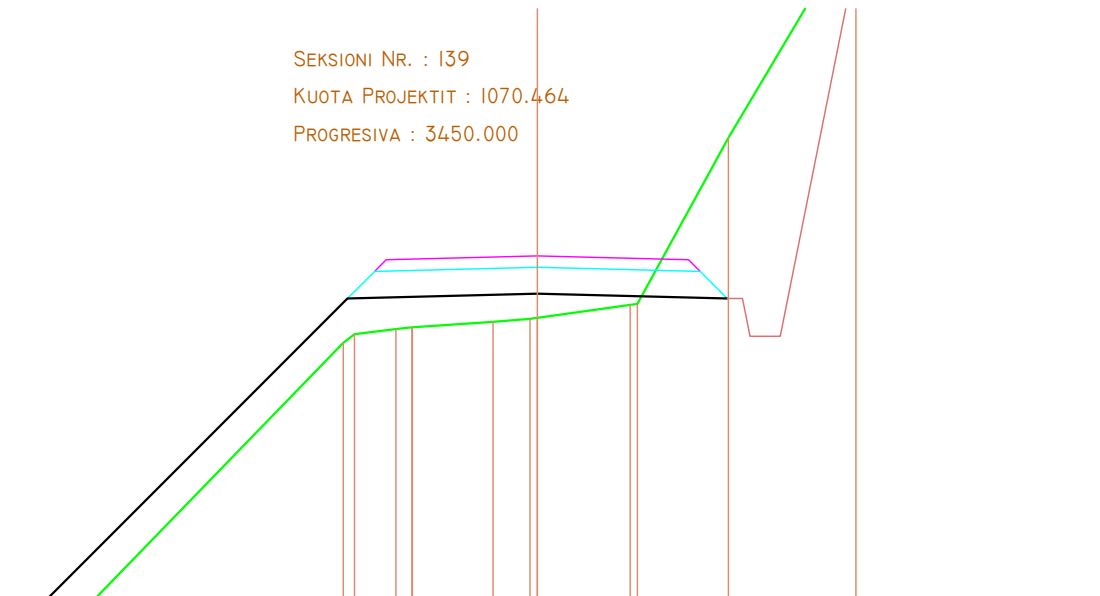

| | | | | | | | | | | | | |
|---------------------------|---------|---------|---------|---------|---------|---------|---------|---------|---------|---------|---------|---------|
| KUOTA E TOKES | 1065.10 | 1069.32 | 1069.44 | 1069.50 | 1069.52 | 1069.59 | 1069.63 | 1069.65 | 1069.82 | 1069.85 | 1072.03 | 1074.86 |
| DIST. PJESORE E TOKES | 4.1 | 0.5 | 0.2 | 1.1 | 0.5 | 1.2 | 1.2 | 1.7 | 3.2 | | | |
| KUOTA E PROJEKTIT | | 1069.90 | | | | 1069.96 | | 1069.90 | | | | |
| DIST. PJESORE E PROJEKTIT | 5.8 | 2.5 | | 2.5 | | | | | | | | |

SEKSIONI NR. : 138
 KUOTA PROJEKTIT : 1070.269
 PROGRESIVA : 3425.000

SHKALLA 1:100

KUOTA REF. 1066.911

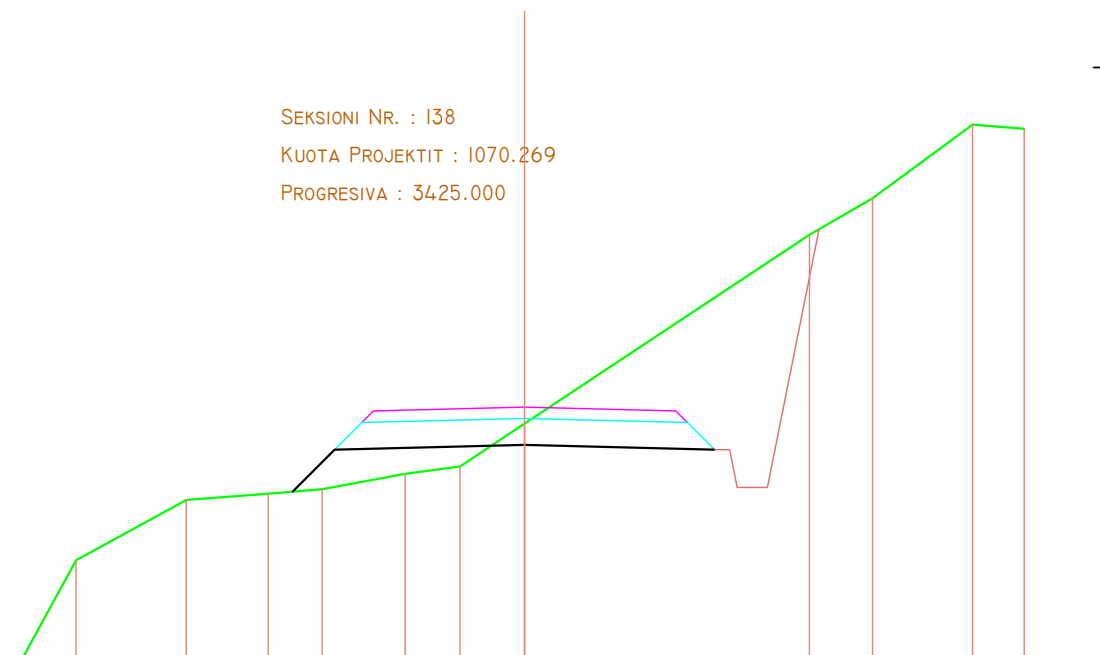

| | | | | | | | | | | | |
|---------------------------|---------|---------|---------|---------|---------|---------|---------|---------|---------|---------|---------|
| KUOTA E TOKES | 1068.24 | 1069.04 | 1069.12 | 1069.18 | 1069.39 | 1069.48 | 1070.05 | 1072.55 | 1073.03 | 1074.00 | 1073.95 |
| DIST. PJESORE E TOKES | 1.5 | 1.1 | 0.7 | 1.1 | 0.7 | 0.9 | 3.8 | 0.8 | 1.3 | 0.7 | |
| KUOTA E PROJEKTIT | | | 1069.15 | 1069.71 | | 1069.77 | | 1069.71 | | | |
| DIST. PJESORE E PROJEKTIT | | | 0.6 | 2.5 | | 2.5 | | | | | |

SEKSIONI NR. : 140
 KUOTA PROJEKTIT : 1070.560
 PROGRESIVA : 3475.000

SHKALLA 1:100

KUOTA REF. 1066.700

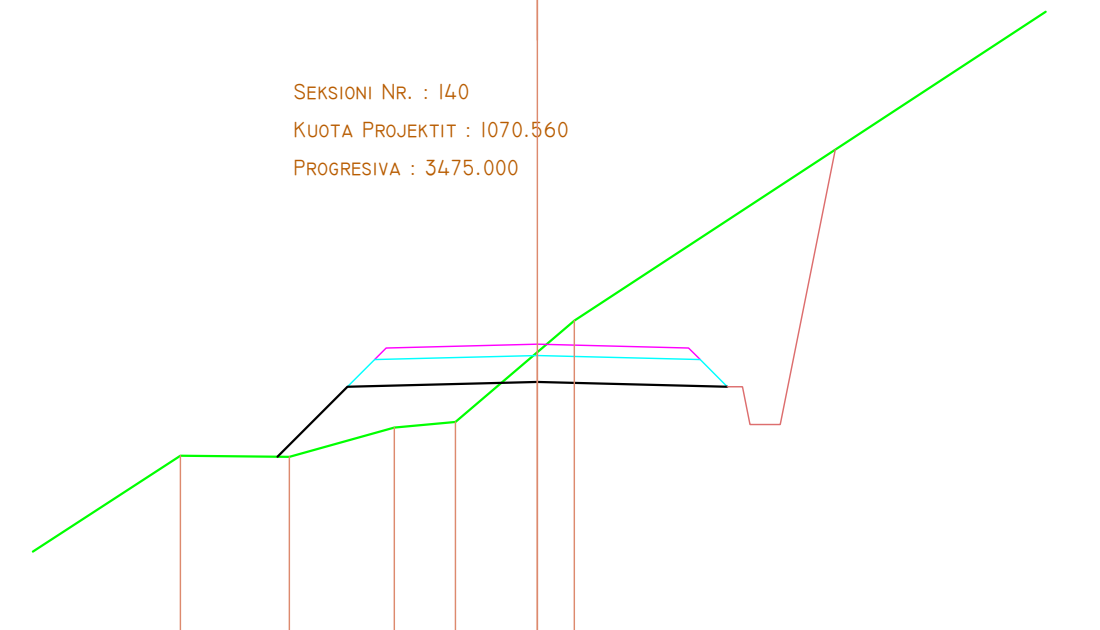

| | | | | | | |
|---------------------------|---------|---------|---------|---------|---------|---------|
| KUOTA E TOKES | 1069.09 | 1069.07 | 1069.46 | 1069.53 | 1070.45 | 1070.87 |
| DIST. PJESORE E TOKES | 2.5 | 1.4 | 1.4 | 0.8 | 1.1 | |
| KUOTA E PROJEKTIT | | 1069.07 | 1070.00 | | | |
| DIST. PJESORE E PROJEKTIT | 0.9 | 2.5 | | | | |



BASHKIA LIBOHOVE
 OBJEKTI:
 RIPARIMIN DHE ASFALTIM I RRUGËS
 AUTOMOBILIS TIKE FUSHA E ÇAJUPIT – TOPOVË,
 PJESË E UNAZËS SË ZAGORISË L= 8971 ML.

Data:
06/2024

EMERTIMI I FLETES:
 PROFIL TERTHOR

SHK
1:1000

HARTOI: SEKTORI SHERBIMIT URBAN
 ARK. NELSON SEJDO

Nr. fleta
35

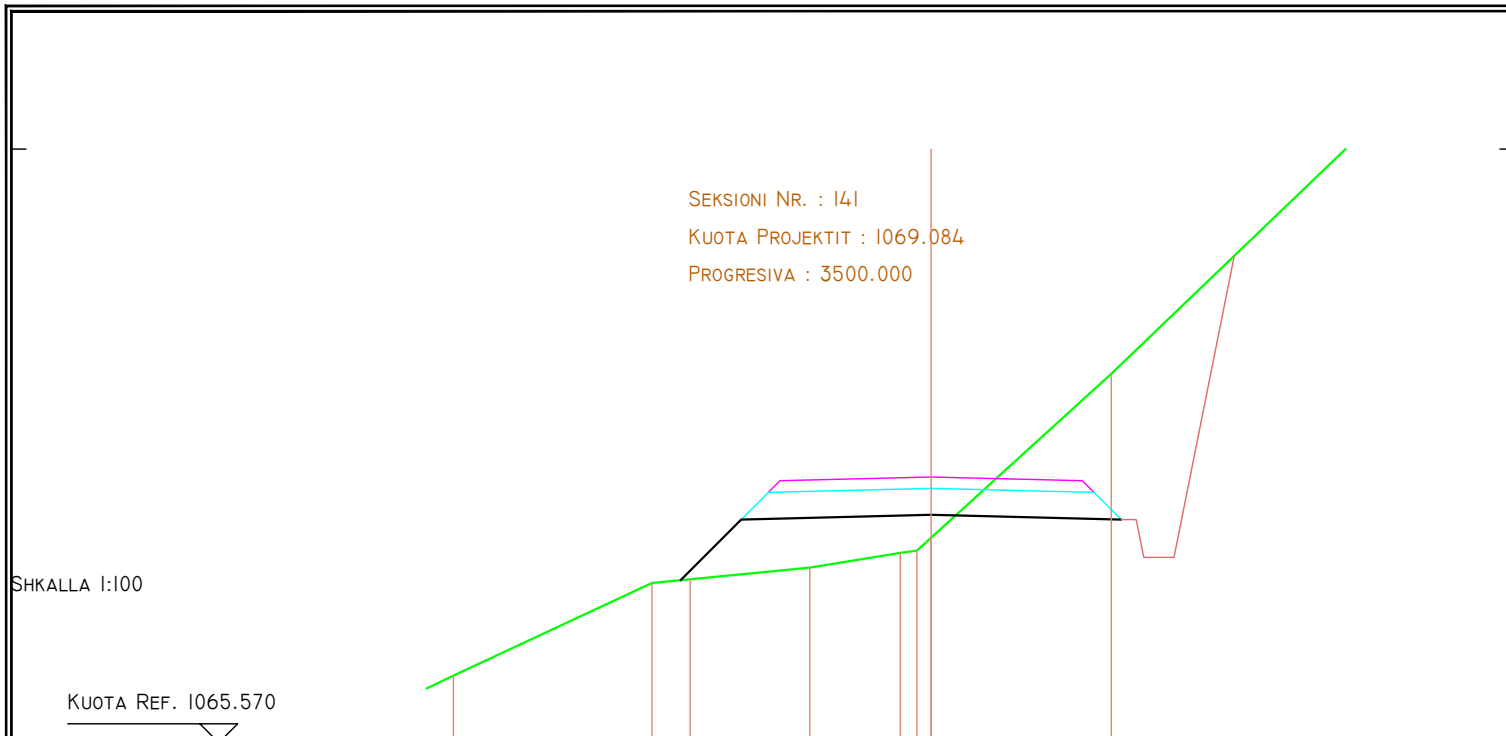

| | | | | | | | | |
|---------------------------|---------|---------|---------|---------|---------|---------|---------|---------|
| KUOTA E TOKES | 1066.46 | 1067.68 | 1067.73 | 1067.88 | 1068.08 | 1068.11 | 1068.28 | 1070.45 |
| DIST. PJESORE E TOKES | 2.6 | 0.5 | 1.6 | 1.2 | 0.2 | 0.2 | 2.4 | 4.4 |
| KUOTA E PROJEKTIT | | 1067.72 | 1068.52 | | 1068.58 | | | 1068.52 |
| DIST. PJESORE E PROJEKTIT | | 0.8 | 2.5 | | 2.5 | | | |

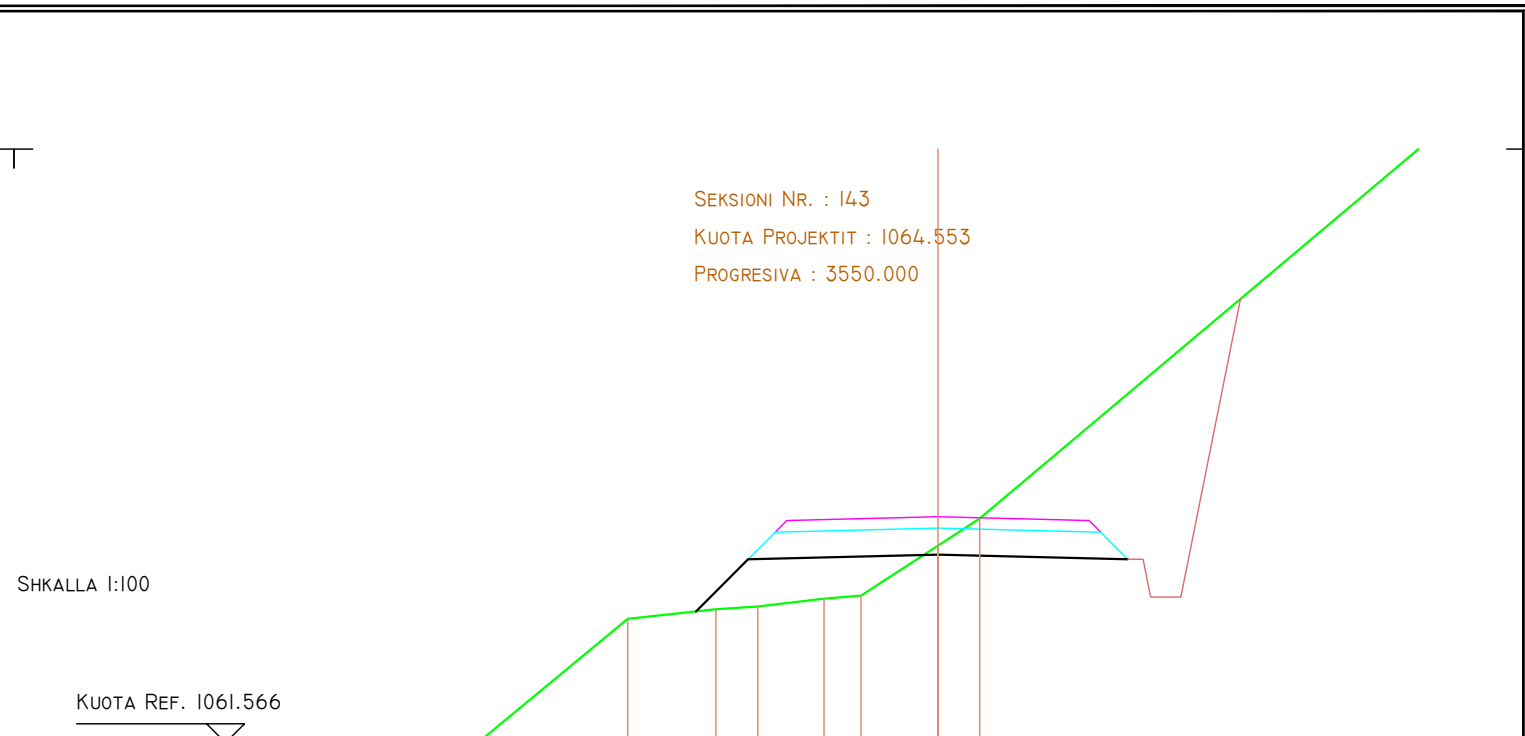

| | | | | | | | | |
|---------------------------|---------|---------|---------|---------|---------|---------|---------|---------|
| KUOTA E TOKES | 1063.20 | 1063.33 | 1063.37 | 1063.47 | 1063.51 | 1064.17 | 1064.53 | |
| DIST. PJESORE E TOKES | 4.3 | 1.2 | 0.6 | 0.9 | 0.5 | 1.0 | 0.6 | 9.7 |
| KUOTA E PROJEKTIT | | 1063.30 | 1063.99 | | | 1064.05 | | 1063.99 |
| DIST. PJESORE E PROJEKTIT | | 0.7 | 2.5 | | | 2.5 | | |

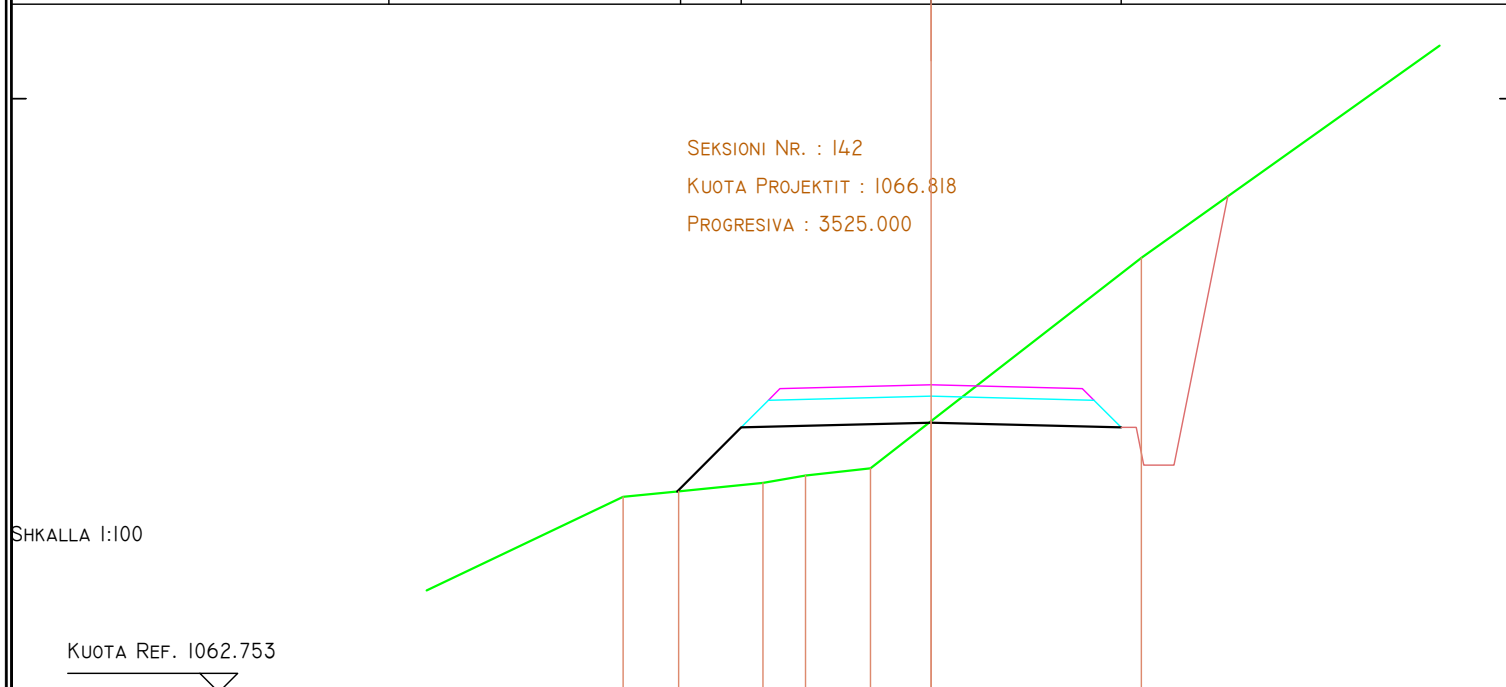

| | | | | | | | |
|---------------------------|---------|---------|---------|---------|---------|---------|---------|
| KUOTA E TOKES | 1065.34 | 1065.41 | 1065.52 | 1065.62 | 1065.71 | 1066.34 | 1068.50 |
| DIST. PJESORE E TOKES | 0.7 | 1.1 | 0.6 | 0.9 | 0.8 | 2.8 | 4.9 |
| KUOTA E PROJEKTIT | | 1065.41 | 1066.26 | | | 1066.32 | 1066.26 |
| DIST. PJESORE E PROJEKTIT | | 0.8 | 2.5 | | | 2.5 | |

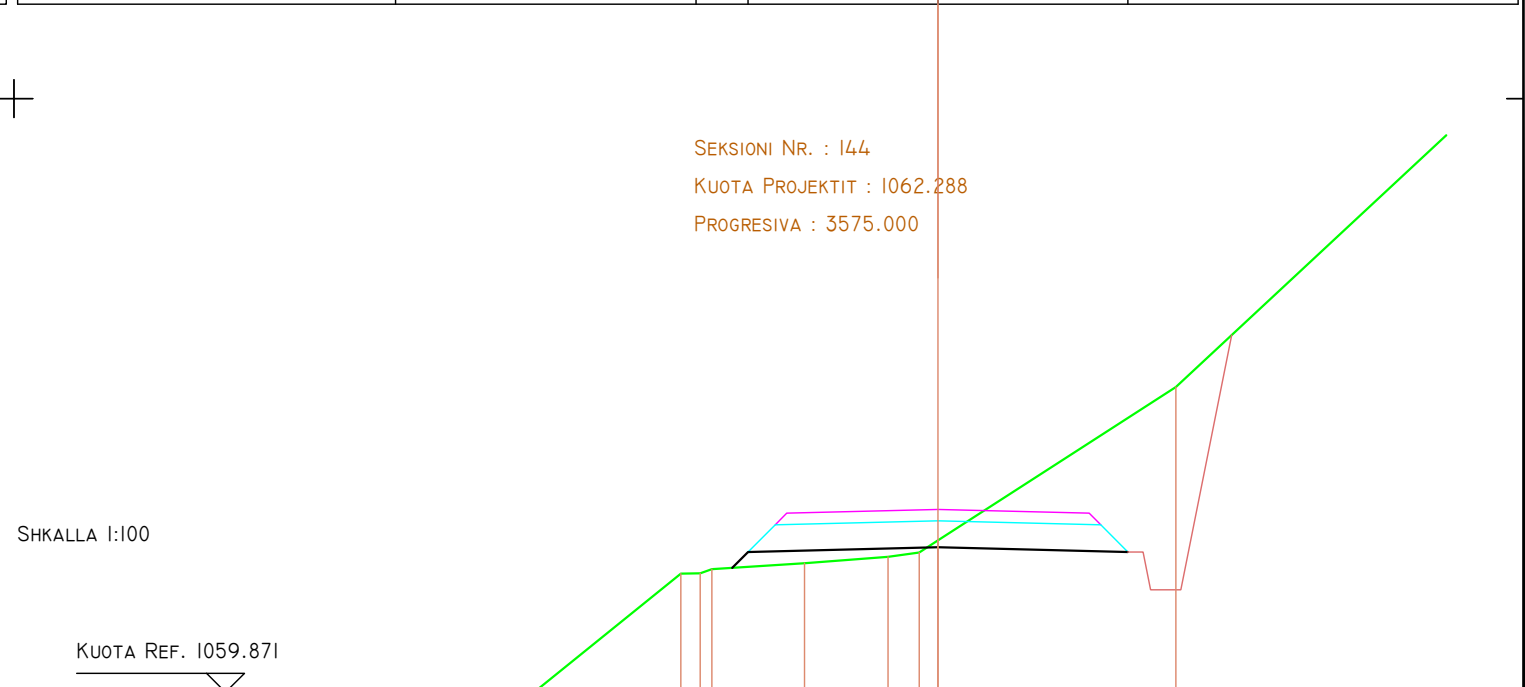

| | | | | | | | | |
|---------------------------|---------|---------|---------|---------|---------|---------|---------|---------|
| KUOTA E TOKES | 1061.44 | 1061.44 | 1061.50 | 1061.58 | 1061.66 | 1061.72 | 1061.88 | 1063.91 |
| DIST. PJESORE E TOKES | 3.5 | 0.3 | 1.2 | 1.1 | 0.4 | | | |
| KUOTA E PROJEKTIT | | 1061.52 | 1061.75 | | | | | |
| DIST. PJESORE E PROJEKTIT | | 0.2 | 2.5 | | | | | |

BASHKIA LIBOHOVE

OBJEKTI:
 RIPARIMIN DHE ASFALTIM I RRUGËS
 AUTOMOBILIS TIKE FUSHA E ÇAJUPIT – TOPOVË,
 PJESË E UNAZËS SË ZAGORISË L= 8971 ML.

EMERTIMI I FLETES:
 PROFIL TERTHOR

HARTOI: SEKTORI SHERBIMIT URBAN
 ARK. NELSON SEJDO

Data: 06/2024
 SHK 1:1000
 Nr. fleta 36

SEKSIONI NR. : 145
 KUOTA PROJEKTIT : 1059.709
 PROGRESIVA : 3600.000

SEKSIONI NR. : 147
 KUOTA PROJEKTIT : 1052.967
 PROGRESIVA : 3650.000

SHKALLA 1:100

SHKALLA 1:100

KUOTA REF. 1058.868

KUOTA REF. 1052.136

| | | | | | | | | | | |
|---------------------------|---------|---------|---------|---------|---------|---------|---------|---------|---------|--|
| KUOTA E TOKES | 1057.76 | 1058.96 | 1058.96 | 1058.98 | 1058.98 | 1059.24 | 1059.41 | 1059.59 | 1059.90 | |
| DIST. PJESORE E TOKES | 3.2 | 1.2 | 0.7 | 1.1 | 1.2 | 0.4 | | | 5.9 | |
| KUOTA E PROJEKTIT | | 1058.97 | 1059.15 | | | | 1059.21 | | 1059.15 | |
| DIST. PJESORE E PROJEKTIT | | 0.2 | | 2.5 | | | 2.5 | | | |

| | | | | | | | | | |
|---------------------------|---------|---------|---------|---------|---------|---------|---------|---------|--|
| KUOTA E TOKES | 1051.95 | 1051.98 | 1051.98 | 1051.97 | 1052.26 | 1052.37 | 1053.03 | 1053.05 | |
| DIST. PJESORE E TOKES | 3.1 | 1.7 | 1.5 | 0.9 | 0.3 | 2.1 | | | |
| KUOTA E PROJEKTIT | | 1051.97 | 1052.40 | | | 1052.47 | | 1052.40 | |
| DIST. PJESORE E PROJEKTIT | | 0.4 | 2.5 | | | 2.5 | | | |

SEKSIONI NR. : 146
 KUOTA PROJEKTIT : 1056.357
 PROGRESIVA : 3625.000

SEKSIONI NR. : 148
 KUOTA PROJEKTIT : 1049.341
 PROGRESIVA : 3675.000

SHKALLA 1:100

SHKALLA 1:100

KUOTA REF. 1055.911

KUOTA REF. 1048.039

| | | | | | | | | | |
|---------------------------|---------|---------|---------|---------|---------|---------|---------|---------|---------|
| KUOTA E TOKES | 1054.83 | 1054.87 | 1054.87 | 1054.92 | 1054.96 | 1055.02 | 1055.43 | 1056.06 | 1060.08 |
| DIST. PJESORE E TOKES | 1.5 | 0.2 | 1.1 | 0.3 | 0.5 | 0.7 | | 5.0 | |
| KUOTA E PROJEKTIT | 1054.83 | 1055.79 | | | | | 1055.86 | | 1055.79 |
| DIST. PJESORE E PROJEKTIT | 1.0 | | 2.5 | | | | 2.5 | | |

| | | | | | | | | | | |
|---------------------------|---------|---------|---------|---------|---------|---------|---------|---------|---------|---------|
| KUOTA E TOKES | 1049.03 | 1049.07 | 1049.16 | 1049.16 | 1049.17 | 1049.24 | 1049.42 | 1049.57 | 1050.97 | 1056.47 |
| DIST. PJESORE E TOKES | | 0.7 | 0.6 | | | | | | | |
| KUOTA E PROJEKTIT | | 1048.81 | 1048.78 | | | | | | | |
| DIST. PJESORE E PROJEKTIT | | 2.5 | | | | | | | | |

BASHKIA LIBOHOVE

OBJEKTI:
 RIPARIMIN DHE ASFALTIM I RRUGËS
 AUTOMOBILIS TIKE FUSHA E ÇAJUPIT – TOPOVË,
 PJESË E UNAZËS SË ZAGORISË L= 8971 ML.

EMERTIMI I FLETES:
 PROFIL TERTHOR

HARTOI: SEKTORI SHERBIMIT URBAN
 ARK. NELSON SEJDO

Data: 06/2024
 SHK 1:1000
 Nr. fleta 37

SEKSIONI NR. : 149
 KUOTA PROJEKTIT : 1045.090
 PROGRESIVA : 3700.000

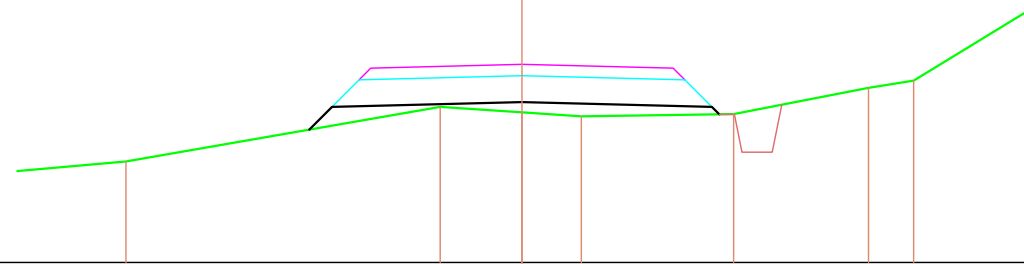

SHKALLA 1:100

KUOTA REF. 1042.470

| | | | | | | | | | | |
|---------------------------|---------|-----|--------------------|---------|---------|-----|--------------------|---------|---------|-----|
| KUOTA E TOKES | 1043.81 | | 1044.53 | 1044.46 | 1044.40 | | 1044.43 | 1044.78 | 1044.87 | |
| DIST. PJESORE E TOKES | | 4.2 | | 1.1 | 0.8 | 2.0 | | 1.8 | 0.6 | 2.4 |
| KUOTA E PROJEKTIT | | | 1044.23 1044.53 | | 1044.59 | | 1044.53 1044.43 | | | |
| DIST. PJESORE E PROJEKTIT | | | 0.3 | 2.5 | | 2.5 | | | | |

SEKSIONI NR. : 151
 KUOTA PROJEKTIT : 1036.566
 PROGRESIVA : 3750.000

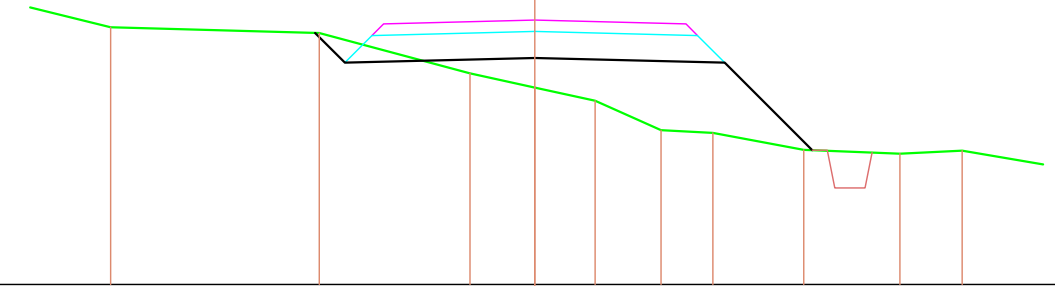

SHKALLA 1:100

KUOTA REF. 1033.071

| | | | | | | | | | | | | |
|---------------------------|---------|-----|--------------------|-----|---------|---------|---------|---------|---------|---------|---------|---------|
| KUOTA E TOKES | 1036.47 | | 1036.40 | | 1035.86 | 1035.67 | 1035.50 | 1035.11 | 1035.07 | 1034.85 | 1034.80 | 1034.84 |
| DIST. PJESORE E TOKES | | 2.8 | | 2.0 | 0.9 | 0.8 | 0.9 | 0.7 | 1.2 | 1.3 | 0.8 | |
| KUOTA E PROJEKTIT | | | 1036.40 1036.00 | | | 1036.07 | | | 1036.00 | 1034.85 | | |
| DIST. PJESORE E PROJEKTIT | | | 0.4 | 2.5 | | 2.5 | | 1.2 | | | | |

SEKSIONI NR. : 150
 KUOTA PROJEKTIT : 1040.828
 PROGRESIVA : 3725.000

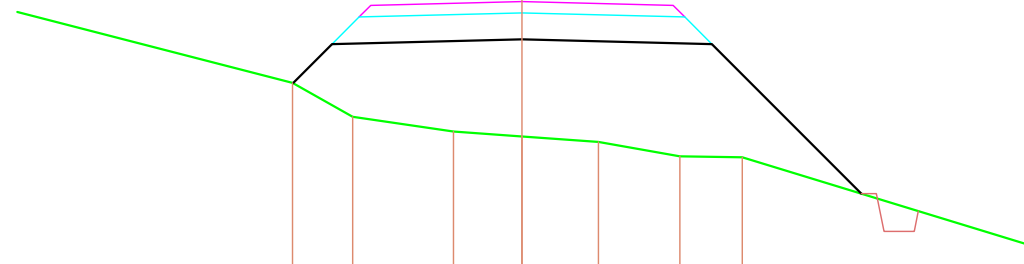

SHKALLA 1:100

KUOTA REF. 1036.168

| | | | | | | | | | |
|---------------------------|--|--------------------|---------|---------|---------|---------|---------|---------|---------|
| KUOTA E TOKES | | 1039.75 | 1039.31 | 1039.11 | 1039.04 | 1038.97 | 1038.78 | 1038.77 | |
| DIST. PJESORE E TOKES | | 0.8 | 1.3 | 0.9 | 1.0 | 1.1 | 0.8 | | 5.6 |
| KUOTA E PROJEKTIT | | 1039.75 1040.27 | | | 1040.33 | | 1040.27 | | 1038.29 |
| DIST. PJESORE E PROJEKTIT | | 0.5 | 2.5 | | 2.5 | | 2.0 | | |

SEKSIONI NR. : 152
 KUOTA PROJEKTIT : 1032.797
 PROGRESIVA : 3775.000

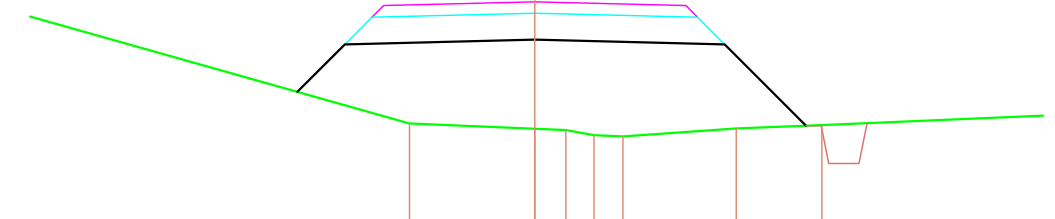

SHKALLA 1:100

KUOTA REF. 1029.912

| | | | | | | | | | | |
|---------------------------|--|-----|---------|---------|---------|---------|---------|--|---------|---------|
| KUOTA E TOKES | | | 1031.19 | 1031.12 | 1031.10 | 1031.03 | 1031.02 | | 1031.12 | 1031.17 |
| DIST. PJESORE E TOKES | | 8.6 | | 1.7 | | | | | | |
| KUOTA E PROJEKTIT | | | 1031.61 | 1032.23 | | | | | | |
| DIST. PJESORE E PROJEKTIT | | | 0.6 | 2.5 | | | | | | |



BASHKIA LIBOHOVE

OBJEKTI:
 RIPARIMIN DHE ASFALTIM I RRUGËS
 AUTOMOBILIS TIKE FUSHA E ÇAJUPIT – TOPOVË,
 PJESË E UNAZËS SË ZAGORISË L= 8971 ML.

Data:

06/2024

EMERTIMI I FLETES:
 PROFIL TERTHOR

SHK
 1:1000

HARTOI: SEKTORI SHERBIMIT URBAN
 ARK. NELSON SEJDO

Nr. fleta
 38

SEKSIONI NR. : 153
 KUOTA PROJEKTIT : 1030.703
 PROGRESIVA : 3800.000

SEKSIONI NR. : 155
 KUOTA PROJEKTIT : 1026.910
 PROGRESIVA : 3850.000

SHKALLA 1:100

SHKALLA 1:100

KUOTA REF. 1026.525

KUOTA REF. 1022.743

| | | | | | | | | | | | | | | | |
|---------------------------|--|---------|---------|---------|--|---------|---------|---------|--|---------|---------|---------|---------|---------|-----|
| KUOTA E TOKES | | 1031.92 | 1031.92 | 1031.91 | | 1031.82 | 1031.83 | 1031.40 | | 1029.05 | 1028.96 | 1028.92 | 1029.00 | 1029.04 | |
| DIST. PJESORE E TOKES | | 0.8 | | 2.0 | | 0.2 | 1.3 | | | 0.6 | 0.8 | 1.1 | 0.5 | | 3.8 |
| KUOTA E PROJEKTIT | | 1030.74 | 1030.14 | | | 1030.20 | | | | | 1030.14 | | 1029.00 | | |
| DIST. PJESORE E PROJEKTIT | | 0.6 | | 2.5 | | | | | | 2.5 | | 1.1 | | | |

| | | | | | | | | | | | | | | |
|---------------------------|--|---------|---------|---------|--|---------|---------|--|--|---------|---------|---------|---------|--|
| KUOTA E TOKES | | 1026.74 | | 1026.52 | | 1026.33 | 1026.31 | | | 1025.99 | | 1025.69 | 1025.63 | |
| DIST. PJESORE E TOKES | | 1.6 | | 1.6 | | 3.6 | | | | 1.5 | | 1.1 | | |
| KUOTA E PROJEKTIT | | 1026.70 | 1026.35 | | | 1026.41 | | | | 1026.35 | 1026.08 | | | |
| DIST. PJESORE E PROJEKTIT | | 0.3 | | 2.5 | | 2.5 | | | | 0.3 | | | | |

SEKSIONI NR. : 154
 KUOTA PROJEKTIT : 1028.807
 PROGRESIVA : 3825.000

SEKSIONI NR. : 156
 KUOTA PROJEKTIT : 1024.802
 PROGRESIVA : 3875.000

SHKALLA 1:100

SHKALLA 1:100

KUOTA REF. 1023.709

KUOTA REF. 1021.320

| | | | | | | | | | | | | | |
|---------------------------|--|---------|---------|---------|-----|---------|---------|---------|--|---------|--|---------|-----|
| KUOTA E TOKES | | 1029.10 | 1029.10 | 1028.94 | | 1028.00 | 1027.58 | 1027.34 | | 1027.18 | | 1027.17 | |
| DIST. PJESORE E TOKES | | 0.6 | 0.3 | | 3.3 | | 1.2 | 0.7 | | 1.7 | | 2.0 | 4.5 |
| KUOTA E PROJEKTIT | | 1028.44 | 1028.24 | | | 1028.31 | | | | 1028.24 | | 1027.17 | |
| DIST. PJESORE E PROJEKTIT | | | 0.2 | | 2.5 | | | 2.5 | | 1.1 | | | |

| | | | | | | | | | | | | | |
|---------------------------|--|---------|---------|---------|--|---------|---------|---------|--|---------|---------|---------|--|
| KUOTA E TOKES | | 1024.54 | | 1024.63 | | 1024.74 | 1024.80 | 1024.76 | | 1024.40 | 1024.40 | 1024.45 | |
| DIST. PJESORE E TOKES | | 2.4 | | | | | | | | | | | |
| KUOTA E PROJEKTIT | | 1024.54 | 1024.24 | | | | | | | | | | |
| DIST. PJESORE E PROJEKTIT | | 0.3 | | 2.5 | | | | | | | | | |



BASHKIA LIBOHOVE

OBJEKTI:
 RIPARIMIN DHE ASFALTIM I RRUGËS
 AUTOMOBILIS TIKE FUSHA E ÇAJUPIT – TOPOVË,
 PJESË E UNAZËS SË ZAGORISË L= 8971 ML.

Data:

06/2024

EMERTIMI I FLETES:
 PROFIL TERTHOR

SHK
 1:1000

HARTOI: SEKTORI SHERBIMIT URBAN
 ARK. NELSON SEJDO

Nr. fleta

39

SEKSIONI NR. : 157
 KUOTA PROJEKTIT : 1021.081
 PROGRESIVA : 3900.000

SHKALLA 1:100

KUOTA REF. 1018.252

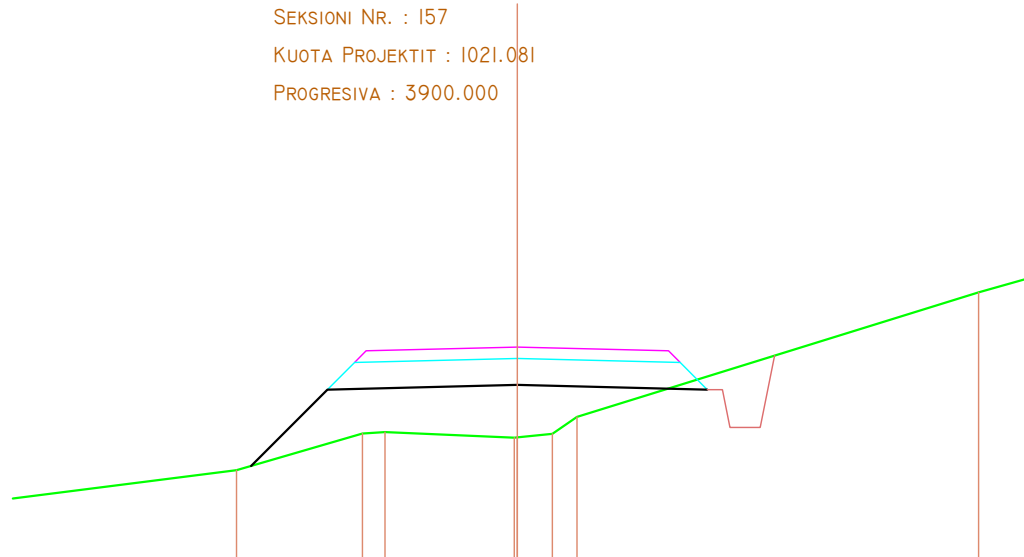

| | | | | | | | | | |
|---------------------------|-----|---------|---------|---------|---------|---------|---------|---------|---------|
| KUOTA E TOKES | | 1019.45 | 1019.94 | 1019.96 | 1019.88 | 1019.89 | 1019.93 | 1020.16 | 1021.80 |
| DIST. PJESORE E TOKES | 3.6 | 1.7 | 0.3 | 1.7 | 0.5 | 0.3 | | 5.3 | |
| KUOTA E PROJEKTIT | | 1019.51 | 1020.52 | | 1020.58 | | | 1020.52 | |
| DIST. PJESORE E PROJEKTIT | | 1.0 | 2.5 | | 2.5 | | | | |

SEKSIONI NR. : 159
 KUOTA PROJEKTIT : 1013.463
 PROGRESIVA : 3950.000

SHKALLA 1:100

KUOTA REF. 1008.034

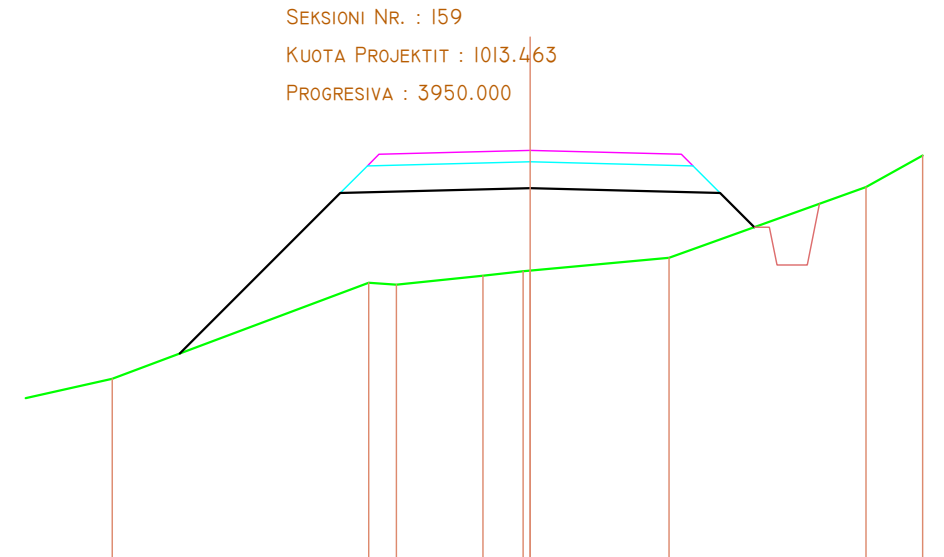

| | | | | | | | | | | |
|---------------------------|--|---------|---------|---------|---------|---------|---------|---------|---------|---------|
| KUOTA E TOKES | | 1010.44 | 1011.71 | 1011.69 | 1011.81 | 1011.87 | 1011.87 | 1012.04 | 1012.98 | 1013.40 |
| DIST. PJESORE E TOKES | | 3.4 | 0.4 | 1.1 | 0.5 | 1.8 | | 2.6 | 0.7 | |
| KUOTA E PROJEKTIT | | 1010.78 | 1012.90 | | 1012.96 | | | 1012.90 | 1012.45 | |
| DIST. PJESORE E PROJEKTIT | | 2.1 | 2.5 | | 2.5 | | | 0.5 | | |

SEKSIONI NR. : 158
 KUOTA PROJEKTIT : 1017.272
 PROGRESIVA : 3925.000

SHKALLA 1:100

KUOTA REF. 1014.012

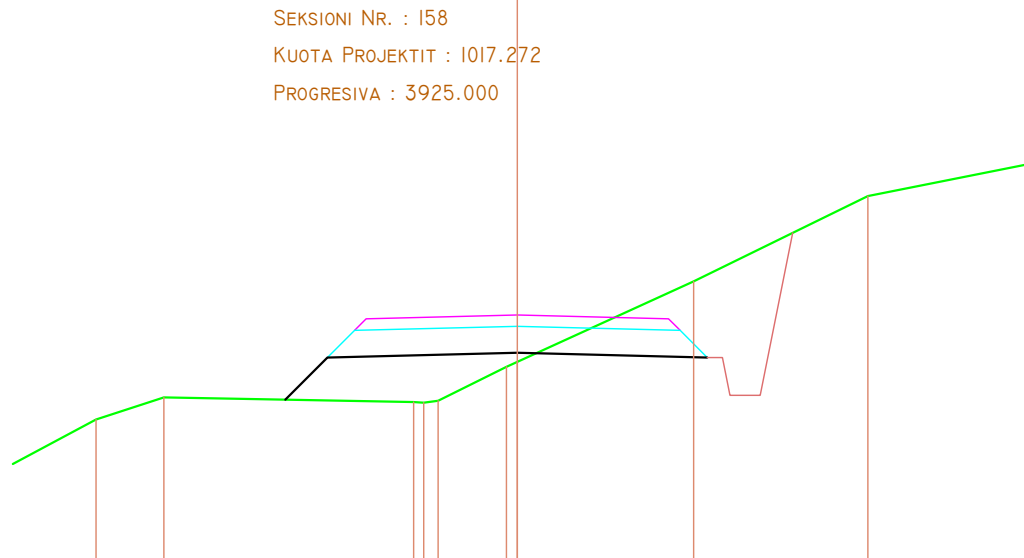

| | | | | | | | | | | |
|---------------------------|--|---------|---------|---------|---------|---------|---------|---------|---------|---------|
| KUOTA E TOKES | | 1015.89 | 1016.18 | 1016.12 | 1016.11 | 1016.14 | 1016.59 | 1016.66 | 1017.72 | 1018.84 |
| DIST. PJESORE E TOKES | | 0.9 | 3.3 | 0.2 | 0.9 | | 2.3 | | 2.3 | |
| KUOTA E PROJEKTIT | | | 1016.15 | 1016.71 | | | 1016.77 | | 1016.71 | |
| DIST. PJESORE E PROJEKTIT | | | 0.6 | 2.5 | | 2.5 | | | | |

SEKSIONI NR. : 160
 KUOTA PROJEKTIT : 1009.655
 PROGRESIVA : 3975.000

SHKALLA 1:100

KUOTA REF. 1005.591

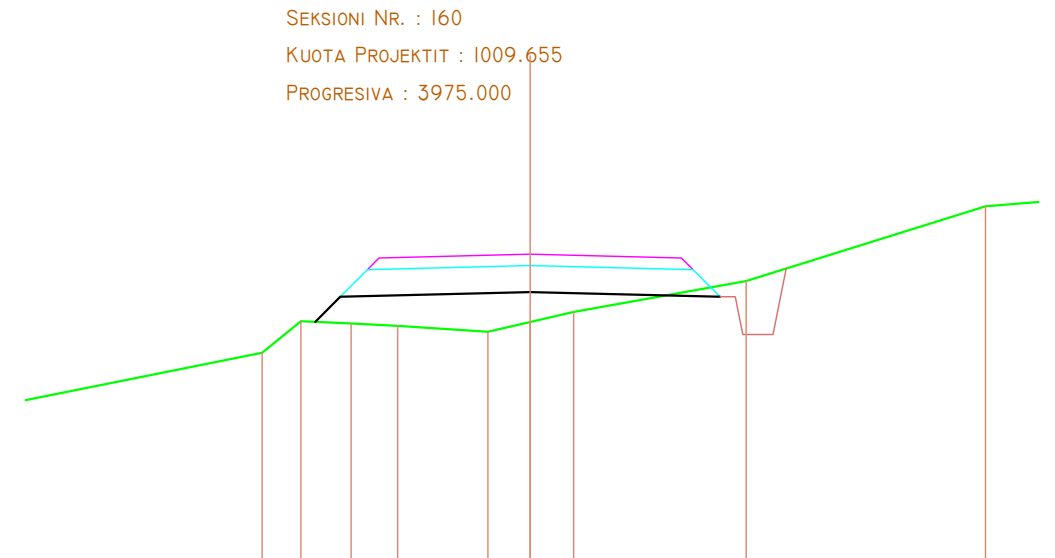

| | | | | | | | | | | |
|---------------------------|--|---------|---------|---------|---------|---------|---------|---------|---------|---------|
| KUOTA E TOKES | | 1008.35 | 1008.77 | 1008.74 | 1008.71 | 1008.63 | 1008.76 | 1008.89 | 1009.30 | 1010.29 |
| DIST. PJESORE E TOKES | | 0.5 | 0.7 | 0.6 | 1.2 | 0.6 | 0.6 | 2.3 | 3.2 | 1.7 |
| KUOTA E PROJEKTIT | | | 1008.76 | 1009.09 | | | | | | |
| DIST. PJESORE E PROJEKTIT | | | 0.3 | 2.5 | | | | | | |



BASHKIA LIBOHOVE

OBJEKTI:
 RIPARIMIN DHE ASFALTIM I RRUGËS
 AUTOMOBILIS TIKE FUSHA E ÇAJUPIT – TOPOVË,
 PJESE E UNAZËS SË ZAGORISË L= 8971 ML.

Data:
 06/2024

EMERTIMI I FLETES:
 PROFIL TERTHOR

SHK
 1:1000

HARTOI: SEKTORI SHERBIMIT URBAN
 ARK. NELSON SEJDO

Nr. fleta
 40

SEKSIONI NR. : 161
 KUOTA PROJEKTIT : 1005.846
 PROGRESIVA : 4000.000

SHKALLA 1:100

KUOTA REF. 1002.973

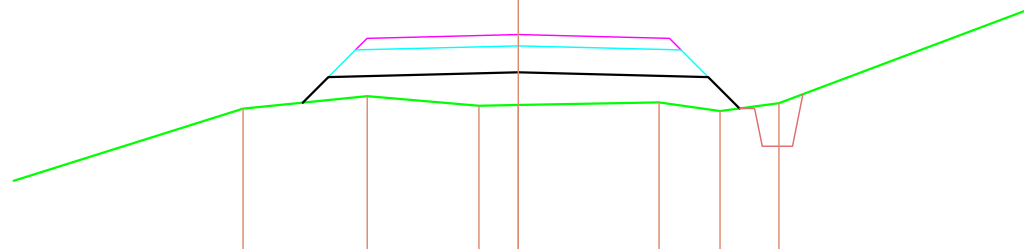

| | | | | | | | |
|---------------------------|---------|---------|---------|---------|---------|---------|---------|
| KUOTA E TOKES | 1004.87 | 1005.05 | 1004.90 | 1004.91 | 1004.95 | 1004.83 | 1004.94 |
| DIST. PJESORE E TOKES | 5.1 | 1.6 | 1.5 | 0.5 | 1.9 | 0.8 | 0.8 |
| KUOTA E PROJEKTIT | 1004.94 | 1005.28 | 1005.35 | 1005.28 | 1004.87 | | |
| DIST. PJESORE E PROJEKTIT | 0.3 | 2.5 | 2.5 | 0.4 | | | |

SEKSIONI NR. : 163
 KUOTA PROJEKTIT : 998.228
 PROGRESIVA : 4050.000

SHKALLA 1:100

KUOTA REF. 995.085

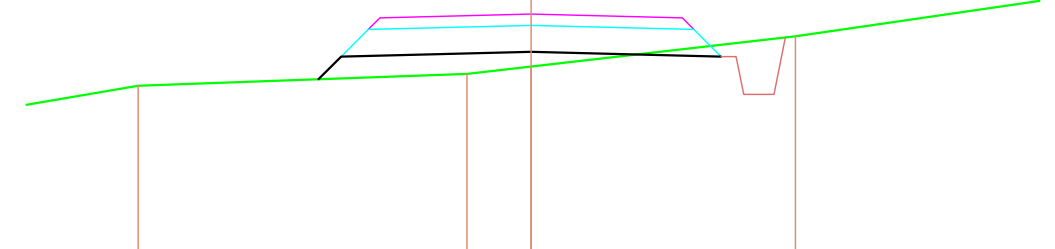

| | | | | |
|---------------------------|--------|--------|--------|--------|
| KUOTA E TOKES | 997.28 | 997.44 | 997.53 | 997.93 |
| DIST. PJESORE E TOKES | 4.3 | 0.8 | 3.5 | 4.3 |
| KUOTA E PROJEKTIT | 997.37 | 997.67 | 997.73 | 997.67 |
| DIST. PJESORE E PROJEKTIT | 0.3 | 2.5 | 2.5 | |

SEKSIONI NR. : 162
 KUOTA PROJEKTIT : 1002.037
 PROGRESIVA : 4025.000

SHKALLA 1:100

KUOTA REF. 999.273

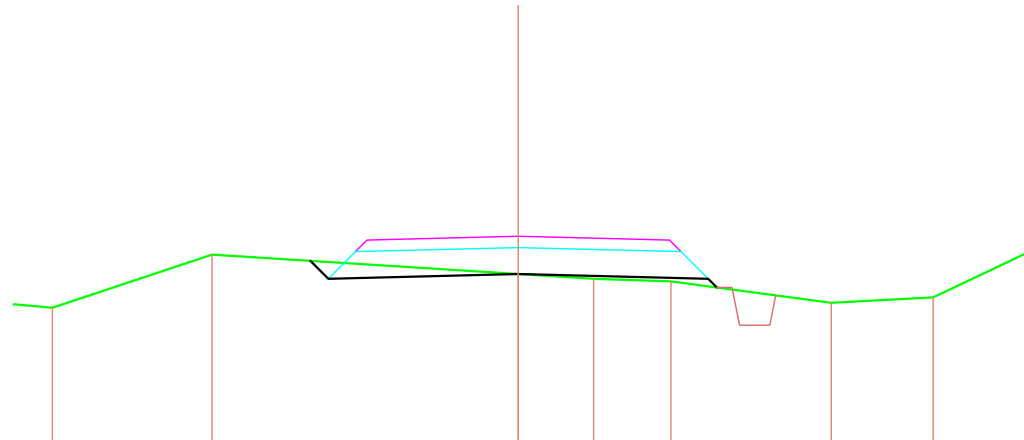

| | | | | | | | |
|---------------------------|---------|---------|---------|---------|---------|---------|---------|
| KUOTA E TOKES | 1001.09 | 1001.79 | 1001.54 | 1001.47 | 1001.44 | 1001.16 | 1001.23 |
| DIST. PJESORE E TOKES | 2.1 | 4.0 | 1.0 | 1.0 | 2.1 | 1.3 | 2.7 |
| KUOTA E PROJEKTIT | 1001.71 | 1001.47 | 1001.54 | 1001.47 | 1001.36 | | |
| DIST. PJESORE E PROJEKTIT | 0.2 | 2.5 | 2.5 | | | | |

SEKSIONI NR. : 164
 KUOTA PROJEKTIT : 994.420
 PROGRESIVA : 4075.000

SHKALLA 1:100

KUOTA REF. 990.418

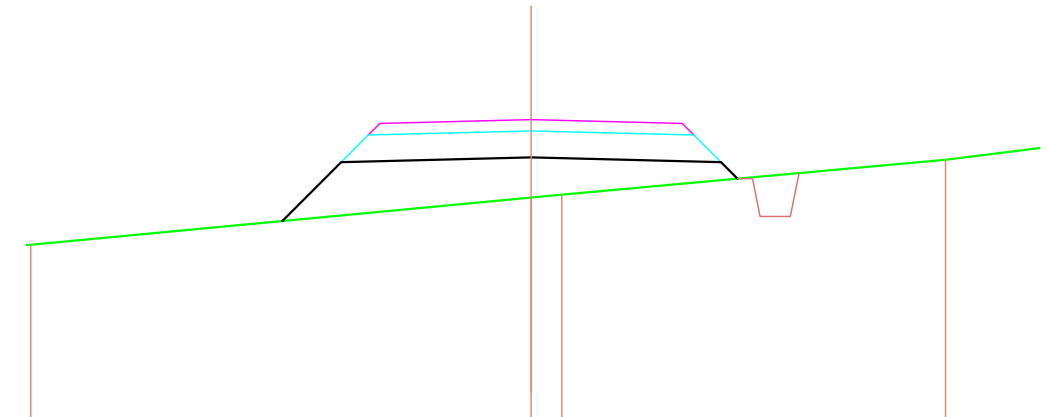

| | | | | |
|---------------------------|--------|--------|--------|--------|
| KUOTA E TOKES | 992.76 | 993.39 | 993.43 | 993.89 |
| DIST. PJESORE E TOKES | 6.6 | 0.4 | 5.1 | |
| KUOTA E PROJEKTIT | 993.08 | 993.86 | | |
| DIST. PJESORE E PROJEKTIT | 0.8 | 2.5 | | |



BASHKIA LIBOHOVE

OBJEKTI:
 RIPARIMIN DHE ASFALTIM I RRUGËS
 AUTOMOBILIS TIKE FUSHA E ÇAJUPIT – TOPOVË,
 PJESE E UNAZËS SË ZAGORISË L= 8971 ML.

Data:

06/2024

EMERTIMI I FLETES:

PROFIL TERTHOR

SHK
 1:1000

HARTOI: SEKTORI SHERBIMIT URBAN
 ARK. NELSON SEJDO

Nr. fleta

41

SEKSIONI NR. : 165
 KUOTA PROJEKTIT : 990.670
 PROGRESIVA : 4100.000

SEKSIONI NR. : 167
 KUOTA PROJEKTIT : 987.381
 PROGRESIVA : 4150.000

SHKALLA 1:100

SHKALLA 1:100

KUOTA REF. 987.568

KUOTA REF. 983.735

| | | | | | |
|---------------------------|------|--------|--------|--------|--------|
| KUOTA E TOKES | | 989.38 | 989.38 | 989.82 | |
| DIST. PJESORE E TOKES | 12.9 | 0.8 | 2.0 | 4.6 | |
| KUOTA E PROJEKTIT | | 989.40 | 990.11 | 990.17 | 990.11 |
| DIST. PJESORE E PROJEKTIT | | 0.7 | 2.5 | 2.5 | 0.3 |

| | | | | | | | | | | |
|---------------------------|--------|--------|--------|--------|--------|--------|--------|--------|--------|--|
| KUOTA E TOKES | 986.26 | 986.41 | 986.64 | 986.68 | 986.67 | 986.69 | 986.69 | 986.67 | 986.72 | |
| DIST. PJESORE E TOKES | 0.5 | 1.6 | 1.3 | 2.4 | 0.6 | 0.3 | 2.5 | 1.1 | 4.9 | |
| KUOTA E PROJEKTIT | | | | 986.68 | 986.82 | 986.88 | | 986.82 | 986.67 | |
| DIST. PJESORE E PROJEKTIT | | | | 2.5 | 2.5 | | | | | |

SEKSIONI NR. : 166
 KUOTA PROJEKTIT : 988.175
 PROGRESIVA : 4125.000

SEKSIONI NR. : 168
 KUOTA PROJEKTIT : 988.279
 PROGRESIVA : 4175.000

SHKALLA 1:100

SHKALLA 1:100

KUOTA REF. 984.336

KUOTA REF. 984.482

| | | | | |
|---------------------------|------|--------|--------|--------|
| KUOTA E TOKES | | 987.30 | 987.73 | |
| DIST. PJESORE E TOKES | 10.8 | 4.1 | | |
| KUOTA E PROJEKTIT | | 986.97 | 987.61 | 987.67 |
| DIST. PJESORE E PROJEKTIT | | 0.6 | 2.5 | 2.5 |

| | | | | | | | |
|---------------------------|--------|--------|--------|--------|--------|--------|--------|
| KUOTA E TOKES | 986.78 | 986.74 | 986.74 | 986.74 | 986.71 | 986.81 | 986.83 |
| DIST. PJESORE E TOKES | 0.9 | 0.5 | 0.6 | 1.5 | 0.3 | | |
| KUOTA E PROJEKTIT | 986.89 | 987.72 | | | | | |
| DIST. PJESORE E PROJEKTIT | 0.8 | 2.5 | | | | | |



BASHKIA LIBOHOVE

OBJEKTI:
 RIPARIMIN DHE ASFALTIM I RRUGËS
 AUTOMOBILIS TIKE FUSHA E ÇAJUPIT – TOPOVË,
 PJESË E UNAZËS SË ZAGORISË L= 8971 ML.

Data:

06/2024

EMERTIMI I FLETES:

PROFIL TERTHOR

SHK
 1:1000

HARTOI: SEKTORI SHERBIMIT URBAN
 ARK. NELSON SEJDO

Nr. fleta

42

SEKSIONI NR. : 169
 KUOTA PROJEKTIT : 990.862
 PROGRESIVA : 4200.000

SEKSIONI NR. : 171
 KUOTA PROJEKTIT : 992.190
 PROGRESIVA : 4250.000

SHKALLA 1:100

SHKALLA 1:100

KUOTA REF. 988.562

KUOTA REF. 989.180

| | | | | | | |
|---------------------------|--------|------------------|------------------|--------|--------|--------|
| KUOTA E TOKES | 991.03 | 990.81 | 990.66 990.65 | 990.45 | 990.55 | 990.52 |
| DIST. PJESORE E TOKES | 1.5 | 2.2 | 3.2 | 2.9 | 1.1 | 1.2 |
| KUOTA E PROJEKTIT | | 990.80 990.30 | 990.36 | 990.30 | | |
| DIST. PJESORE E PROJEKTIT | | 0.5 | 2.5 | 2.5 | | |

| | | | | | | |
|---------------------------|--------|--------|--------|--------|--------|--------|
| KUOTA E TOKES | 990.90 | 991.97 | 991.72 | 991.75 | 991.90 | 991.93 |
| DIST. PJESORE E TOKES | 4.8 | 0.5 | 0.5 | 1.8 | 1.0 | 6.2 |
| KUOTA E PROJEKTIT | 991.63 | 991.69 | 991.63 | | | |
| DIST. PJESORE E PROJEKTIT | | 2.5 | 2.5 | | | |

SEKSIONI NR. : 170
 KUOTA PROJEKTIT : 992.586
 PROGRESIVA : 4225.000

SEKSIONI NR. : 172
 KUOTA PROJEKTIT : 991.733
 PROGRESIVA : 4275.000

SHKALLA 1:100

SHKALLA 1:100

KUOTA REF. 988.816

KUOTA REF. 989.806

| | | | | | |
|---------------------------|------------------|--------|------------------|--------|--------|
| KUOTA E TOKES | 991.25 | 991.93 | 991.93 | 991.94 | 991.97 |
| DIST. PJESORE E TOKES | 2.8 | 0.5 | 0.8 | 2.2 | |
| KUOTA E PROJEKTIT | 991.25 992.02 | 992.09 | 992.02 991.97 | | |
| DIST. PJESORE E PROJEKTIT | 0.8 | 2.5 | 2.5 | | |

| | | | | | |
|---------------------------|------------------|--------|--------|----------------------------|-----|
| KUOTA E TOKES | 991.03 | 991.12 | 991.21 | 991.43 991.44 991.44 | |
| DIST. PJESORE E TOKES | 6.3 | 1.6 | 1.1 | 2.5 | 8.5 |
| KUOTA E PROJEKTIT | 991.05 991.17 | 2.5 | | | |
| DIST. PJESORE E PROJEKTIT | | | | | |



BASHKIA LIBOHOVE

OBJEKTI:
 RIPARIMIN DHE ASFALTIM I RRUGËS
 AUTOMOBILIS TIKE FUSHA E ÇAJUPIT – TOPOVË,
 PJESË E UNAZËS SË ZAGORISË L= 8971 ML.

Data:
 06/2024

EMERTIMI I FLETES:

PROFIL TERTHOR

SHK
 1:1000

HARTOI: SEKTORI SHERBIMIT URBAN
 ARK. NELSON SEJDO

Nr. fleta
 43

SEKSIONI NR. : 173
 KUOTA PROJEKTIT : 991.034
 PROGRESIVA : 4300.000

SHKALLA 1:100

KUOTA REF. 988.175

| | | | | | |
|---------------------------|------------------|----------------------------|--------|--------|--|
| KUOTA E TOKES | 990.90 | 991.06 991.06 991.04 | 990.78 | 990.50 | |
| DIST. PJESORE E TOKES | 0.9 | 1.8 | 1.9 | 5.3 | |
| KUOTA E PROJEKTIT | 990.90 990.47 | | 990.53 | 990.47 | |
| DIST. PJESORE E PROJEKTIT | 0.4 | 2.5 | 2.5 | | |

SEKSIONI NR. : 175
 KUOTA PROJEKTIT : 988.985
 PROGRESIVA : 4350.000

SHKALLA 1:100

KUOTA REF. 985.993

| | | | | | | |
|---------------------------|--|------------------|------------------|--------|--------|-----|
| KUOTA E TOKES | | 988.29 | 988.52 988.51 | 988.43 | 988.50 | |
| DIST. PJESORE E TOKES | | 1.1 | 0.2 | 2.0 | 0.8 | 4.8 |
| KUOTA E PROJEKTIT | | 987.95 988.42 | 988.48 | | 988.42 | |
| DIST. PJESORE E PROJEKTIT | | 0.5 | 2.5 | 2.5 | | |

SEKSIONI NR. : 174
 KUOTA PROJEKTIT : 989.576
 PROGRESIVA : 4325.000

SHKALLA 1:100

KUOTA REF. 986.815

| | | | | | | |
|---------------------------|--|------------------|--------|--------|--------|--------|
| KUOTA E TOKES | | 989.38 | 989.19 | 989.19 | 989.19 | 989.11 |
| DIST. PJESORE E TOKES | | 1.3 | 0.6 | 1.3 | 1.4 | |
| KUOTA E PROJEKTIT | | 989.23 989.01 | | 989.08 | | 989.01 |
| DIST. PJESORE E PROJEKTIT | | 0.2 | 2.5 | 2.5 | | |

SEKSIONI NR. : 176
 KUOTA PROJEKTIT : 988.504
 PROGRESIVA : 4375.000

SHKALLA 1:100

KUOTA REF. 985.350

| | | | | | | | |
|---------------------------|--|------------------|--|--------|--------|--------|--------|
| KUOTA E TOKES | | 986.71 | | 987.89 | 987.88 | 987.86 | 987.95 |
| DIST. PJESORE E TOKES | | 4.8 | | 1.1 | 0.8 | 1.1 | 7.0 |
| KUOTA E PROJEKTIT | | 987.41 987.94 | | | | | |
| DIST. PJESORE E PROJEKTIT | | 0.5 | | 2.5 | | | |



BASHKIA LIBOHOVE

OBJEKTI:
 RIPARIMIN DHE ASFALTIM I RRUGËS
 AUTOMOBILIS TIKE FUSHA E ÇAJUPIT – TOPOVË,
 PJESË E UNAZËS SË ZAGORISË L= 8971 ML.

Data:
 06/2024

EMERTIMI I FLETES:
 PROFIL TERTHOR

SHK
 1:1000

HARTOI: SEKTORI SHERBIMIT URBAN
 ARK. NELSON SEJDO

Nr. fleta
 44

SEKSIONI NR. : 177
 KUOTA PROJEKTIT : 988.023
 PROGRESIVA : 4400.000

SEKSIONI NR. : 179
 KUOTA PROJEKTIT : 987.062
 PROGRESIVA : 4450.000

SHKALLA 1:100

SHKALLA 1:100

KUOTA REF. 984.895

KUOTA REF. 984.296

| | | | | | | |
|---------------------------|--------|--------|--------|--------|--------|--------|
| KUOTA E TOKES | 986.50 | 987.05 | 987.07 | 987.42 | 987.78 | 988.76 |
| DIST. PJESORE E TOKES | 2.5 | 0.4 | 1.6 | 1.6 | 3.1 | |
| KUOTA E PROJEKTIT | 986.79 | 987.46 | | 987.52 | 987.46 | |
| DIST. PJESORE E PROJEKTIT | 0.7 | 2.5 | | 2.5 | | |

| | | | | | | |
|---------------------------|--------|--------|--------|--------|--------|--------|
| KUOTA E TOKES | 985.48 | 986.32 | 986.65 | 986.80 | 986.83 | 988.75 |
| DIST. PJESORE E TOKES | 3.9 | 1.8 | 0.8 | 0.6 | 4.7 | |
| KUOTA E PROJEKTIT | 986.08 | 986.50 | 986.56 | | 986.50 | |
| DIST. PJESORE E PROJEKTIT | 0.4 | 2.5 | 2.5 | | | |

SEKSIONI NR. : 178
 KUOTA PROJEKTIT : 987.543
 PROGRESIVA : 4425.000

SEKSIONI NR. : 180
 KUOTA PROJEKTIT : 986.581
 PROGRESIVA : 4475.000

SHKALLA 1:100

SHKALLA 1:100

KUOTA REF. 984.400

KUOTA REF. 983.412

| | | | | | | |
|---------------------------|--------|--------|--------|--------|--------|--------|
| KUOTA E TOKES | 986.07 | 986.27 | 986.97 | 987.03 | 987.13 | 987.19 |
| DIST. PJESORE E TOKES | 0.9 | 4.2 | 0.9 | 1.3 | 0.8 | 7.7 |
| KUOTA E PROJEKTIT | 986.63 | 986.98 | 987.04 | | 986.98 | |
| DIST. PJESORE E PROJEKTIT | 0.3 | 2.5 | 2.5 | | | |

| | | | | | |
|---------------------------|--------|--------|--------|--------|--------|
| KUOTA E TOKES | 985.01 | 986.07 | 985.94 | 985.92 | 985.90 |
| DIST. PJESORE E TOKES | 4.4 | 1.8 | | | |
| KUOTA E PROJEKTIT | 985.85 | 986.02 | | | |
| DIST. PJESORE E PROJEKTIT | 0.2 | 2.5 | | | |



BASHKIA LIBOHOVE

OBJEKTI:
 RIPARIMIN DHE ASFALTIM I RRUGËS
 AUTOMOBILIS TIKE FUSHA E ÇAJUPIT – TOPOVË,
 PJESË E UNAZËS SË ZAGORISË L= 8971 ML.

Data:

06/2024

EMERTIMI I FLETES:
 PROFIL TERTHOR

SHK
 1:1000

HARTOI: SEKTORI SHERBIMIT URBAN
 ARK. NELSON SEJDO

Nr. fleta

45

SEKSIONI NR. : 181
 KUOTA PROJEKTIT : 986.100
 PROGRESIVA : 4500.000

SEKSIONI NR. : 183
 KUOTA PROJEKTIT : 985.138
 PROGRESIVA : 4550.000

SHKALLA 1:100

SHKALLA 1:100

KUOTA REF. 983.004

KUOTA REF. 982.845

| | | | | | | |
|---------------------------|------------------|--------|--------|--------|--------|--------|
| KUOTA E TOKES | 985.08 | 985.71 | 985.68 | 985.64 | 985.64 | 986.80 |
| DIST. PJESORE E TOKES | 3.2 | 0.7 | 1.5 | 0.8 | 3.4 | |
| KUOTA E PROJEKTIT | 985.32 985.54 | 985.60 | 985.54 | | | |
| DIST. PJESORE E PROJEKTIT | 0.2 | 2.5 | 2.5 | | | |

| | | | | | |
|---------------------------|------------------|--------|--------|--------|--|
| KUOTA E TOKES | 984.36 | 984.38 | 984.77 | 985.01 | |
| DIST. PJESORE E TOKES | 0.6 | 1.5 | 0.9 | 7.8 | |
| KUOTA E PROJEKTIT | 984.20 984.58 | 984.64 | 984.64 | 984.96 | |
| DIST. PJESORE E PROJEKTIT | 0.4 | 2.5 | 2.5 | | |

SEKSIONI NR. : 182
 KUOTA PROJEKTIT : 985.619
 PROGRESIVA : 4525.000

SEKSIONI NR. : 184
 KUOTA PROJEKTIT : 984.658
 PROGRESIVA : 4575.000

SHKALLA 1:100

SHKALLA 1:100

KUOTA REF. 982.235

KUOTA REF. 982.890

| | | | | | | |
|---------------------------|------------------|--------|------------------|--------|--------|-----|
| KUOTA E TOKES | 984.87 | 984.82 | 984.74 | 984.67 | 985.78 | |
| DIST. PJESORE E TOKES | 10.0 | 0.7 | 1.1 | 1.1 | 1.3 | 5.0 |
| KUOTA E PROJEKTIT | 984.21 985.06 | 985.12 | 985.06 984.98 | | | |
| DIST. PJESORE E PROJEKTIT | 0.8 | 2.5 | 2.5 | | | |

| | | | | |
|---------------------------|------------------|--------|----------------------------|--------|
| KUOTA E TOKES | 983.91 | 983.74 | 983.89 983.92 984.02 | 984.86 |
| DIST. PJESORE E TOKES | 1.4 | 3.1 | | |
| KUOTA E PROJEKTIT | 983.77 984.09 | | | |
| DIST. PJESORE E PROJEKTIT | 0.3 | 2.5 | | |



BASHKIA LIBOHOVE

OBJEKTI:
 RIPARIMIN DHE ASFALTIM I RRUGËS
 AUTOMOBILIS TIKE FUSHA E ÇAJUPIT – TOPOVË,
 PJESE E UNAZËS SË ZAGORISË L= 8971 ML.

Data:
 06/2024

EMERTIMI I FLETES:
 PROFIL TERTHOR

SHK
 1:1000

HARTOI: SEKTORI SHERBIMIT URBAN
 ARK. NELSON SEJDO

Nr. fleta
 46

SEKSIONI NR. : 185
 KUOTA PROJEKTIT : 984.177
 PROGRESIVA : 4600.000

SHKALLA 1:100

KUOTA REF. 980.929

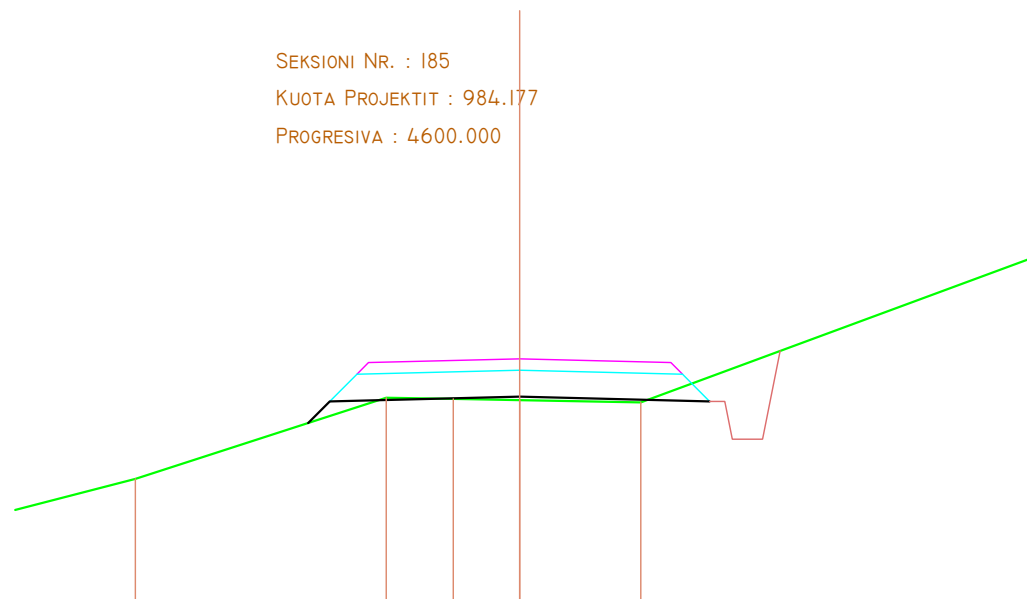

| | | | | | | |
|---------------------------|------------------|--------|--------|--------|--------|--|
| KUOTA E TOKES | 982.59 | 983.66 | 983.65 | 983.63 | 983.60 | |
| DIST. PJESORE E TOKES | 3.3 | 0.9 | 0.9 | 1.6 | 6.9 | |
| KUOTA E PROJEKTIT | 983.33 983.61 | | 983.68 | 983.61 | | |
| DIST. PJESORE E PROJEKTIT | 0.3 | 2.5 | 2.5 | | | |

SEKSIONI NR. : 187
 KUOTA PROJEKTIT : 982.538
 PROGRESIVA : 4650.000

SHKALLA 1:100

KUOTA REF. 980.454

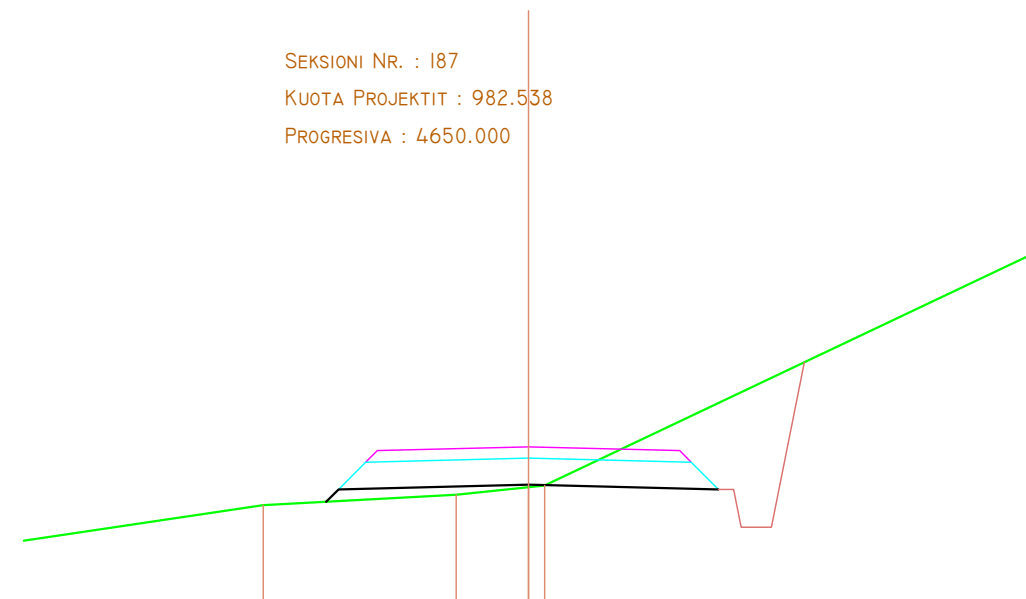

| | | | | |
|---------------------------|------------------|--------|------------------|--------|
| KUOTA E TOKES | 981.77 | 981.90 | 982.00 982.03 | |
| DIST. PJESORE E TOKES | 2.6 | 1.0 | 0.2 | 7.0 |
| KUOTA E PROJEKTIT | 981.81 981.97 | | 982.04 | 981.97 |
| DIST. PJESORE E PROJEKTIT | 0.2 | 2.5 | 2.5 | |

SEKSIONI NR. : 186
 KUOTA PROJEKTIT : 983.531
 PROGRESIVA : 4625.000

SHKALLA 1:100

KUOTA REF. 980.219

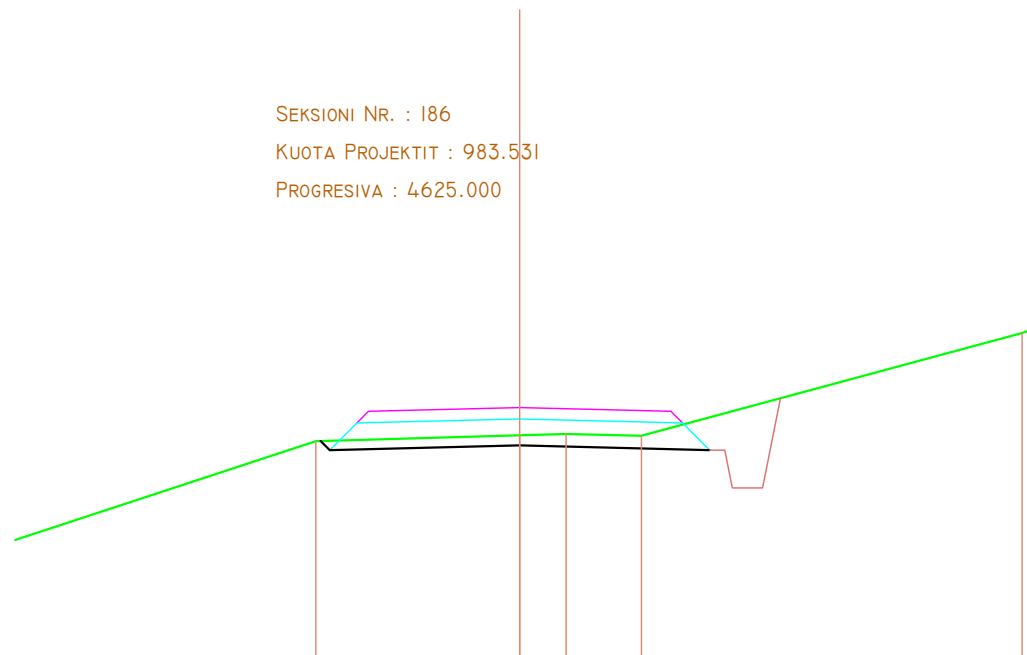

| | | | | | |
|---------------------------|------------------|--------|--------|--------|--|
| KUOTA E TOKES | 983.09 | 983.16 | 983.18 | 983.16 | |
| DIST. PJESORE E TOKES | 2.7 | 0.6 | 1.0 | 5.0 | |
| KUOTA E PROJEKTIT | 983.09 982.97 | 983.03 | | 982.97 | |
| DIST. PJESORE E PROJEKTIT | 2.5 | 2.5 | | | |

SEKSIONI NR. : 188
 KUOTA PROJEKTIT : 981.999
 PROGRESIVA : 4675.000

SHKALLA 1:100

KUOTA REF. 979.056

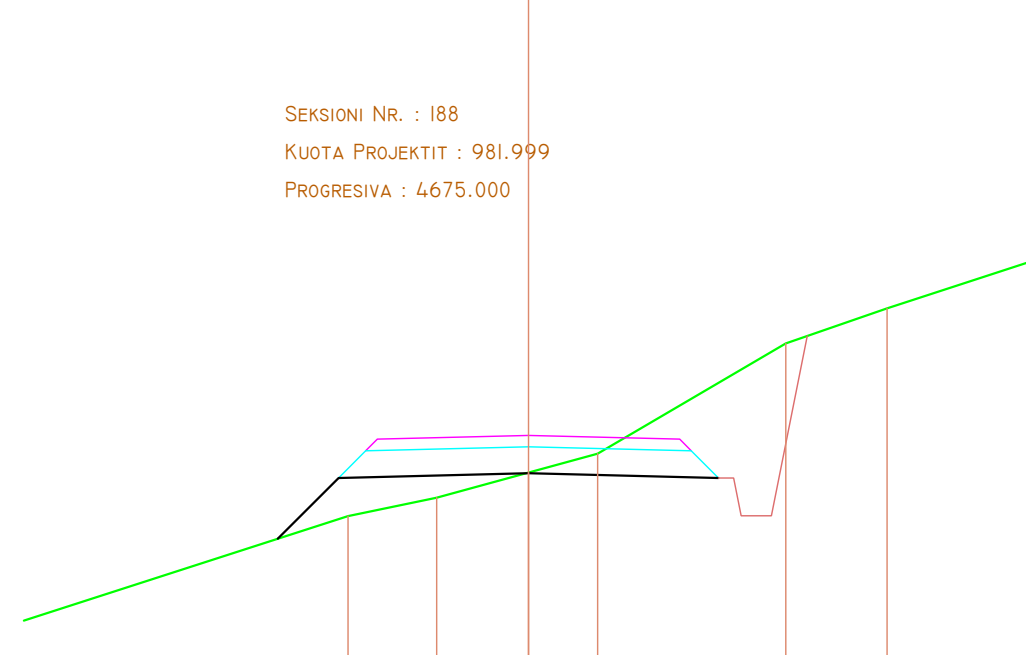

| | | | | | | |
|---------------------------|------------------|--------|--------|--------|--------|--------|
| KUOTA E TOKES | 980.93 | 981.18 | 981.51 | 981.76 | 983.21 | 983.68 |
| DIST. PJESORE E TOKES | 1.2 | 1.2 | | | | |
| KUOTA E PROJEKTIT | 980.63 981.44 | | | | | |
| DIST. PJESORE E PROJEKTIT | 0.8 | 2.5 | | | | |



BASHKIA LIBOHOVE
 OBJEKTI:
 RIPARIMIN DHE ASFALTIM I RRUGËS
 AUTOMOBILIS TIKE FUSHA E ÇAJUPIT – TOPOVË,
 PJESË E UNAZËS SË ZAGORISË L= 8971 ML.

Data:
06/2024

EMERTIMI I FLETES:
 PROFIL TERTHOR

SHK
1:1000

HARTOI: SEKTORI SHERBIMIT URBAN
 ARK. NELSON SEJDO

Nr. fleta
47

SEKSIONI NR. : 189
 KUOTA PROJEKTIT : 981.870
 PROGRESIVA : 4700.000

SEKSIONI NR. : 191
 KUOTA PROJEKTIT : 979.313
 PROGRESIVA : 4750.000

SHKALLA 1:100

SHKALLA 1:100

KUOTA REF. 979.381

KUOTA REF. 977.544

| | | | | | | |
|---------------------------|--------|--------|--------|--------|--------|--------|
| KUOTA E TOKES | 980.07 | 981.04 | 981.36 | 981.45 | 981.76 | 982.89 |
| DIST. PJESORE E TOKES | 3.0 | 1.5 | 0.4 | 1.4 | 4.5 | |
| KUOTA E PROJEKTIT | 980.66 | 981.31 | 981.37 | 981.31 | | |
| DIST. PJESORE E PROJEKTIT | 0.7 | 2.5 | 2.5 | | | |

| | | | | | | |
|---------------------------|--------|--------|--------|--------|--------|--------|
| KUOTA E TOKES | 978.42 | 978.14 | 978.14 | 978.15 | 978.25 | 979.13 |
| DIST. PJESORE E TOKES | 3.0 | 3.1 | 0.5 | 0.3 | 2.9 | |
| KUOTA E PROJEKTIT | 978.32 | 978.75 | 978.81 | 978.75 | | |
| DIST. PJESORE E PROJEKTIT | 0.4 | 2.5 | 2.5 | | | |

SEKSIONI NR. : 190
 KUOTA PROJEKTIT : 981.595
 PROGRESIVA : 4725.000

SEKSIONI NR. : 192
 KUOTA PROJEKTIT : 976.628
 PROGRESIVA : 4775.000

SHKALLA 1:100

SHKALLA 1:100

KUOTA REF. 979.061

KUOTA REF. 975.205

| | | | | | | |
|---------------------------|--------|--------|--------|--------|--------|--------|
| KUOTA E TOKES | 980.39 | 980.50 | 981.54 | 981.60 | 981.74 | 982.42 |
| DIST. PJESORE E TOKES | 0.8 | 3.4 | 0.4 | 0.9 | 4.1 | |
| KUOTA E PROJEKTIT | 980.82 | 981.05 | 981.10 | 981.03 | | |
| DIST. PJESORE E PROJEKTIT | 0.2 | 2.5 | 2.5 | | | |

| | | | | | | |
|---------------------------|--------|--------|--------|--------|--------|--------|
| KUOTA E TOKES | 976.44 | 976.28 | 976.28 | 976.43 | 976.61 | 977.30 |
| DIST. PJESORE E TOKES | 0.7 | 1.5 | 1.0 | 1.0 | 0.0 | |
| KUOTA E PROJEKTIT | 976.74 | 976.06 | | | | |
| DIST. PJESORE E PROJEKTIT | 0.7 | 2.5 | | | | |

BASHKIA LIBOHOVE

OBJEKTI:
 RIPARIMIN DHE ASFALTIM I RRUGËS
 AUTOMOBILIS TIKE FUSHA E ÇAJUPIT – TOPOVË,
 PJESË E UNAZËS SË ZAGORISË L= 8971 ML.

EMERTIMI I FLETES:
 PROFIL TERTHOR

HARTOI: SEKTORI SHERBIMIT URBAN
 ARK. NELSON SEJDO

Data: 06/2024
 SHK 1:1000
 Nr. fleta 48

SEKSIONI NR. : 193
 KUOTA PROJEKTIT : 973.942
 PROGRESIVA : 4800.000

SEKSIONI NR. : 195
 KUOTA PROJEKTIT : 967.316
 PROGRESIVA : 4850.000

SHKALLA 1:100

SHKALLA 1:100

KUOTA REF. 972.814

KUOTA REF. 964.730

| | | | | | | | | | |
|---------------------------|--|--------|--------|--------|--|--------|--------|--------|-----|
| KUOTA E TOKES | | | 973.41 | 973.34 | | 973.14 | 973.14 | 972.96 | |
| DIST. PJESORE E TOKES | | | 0.8 | 2.0 | | 0.8 | 0.7 | | 3.7 |
| KUOTA E PROJEKTIT | | 974.53 | 973.38 | 973.44 | | 973.38 | 973.14 | | |
| DIST. PJESORE E PROJEKTIT | | 1.2 | 2.5 | 2.5 | | 0.2 | | | |

| | | | | | | | | | |
|---------------------------|--|-----|--------|--------|--------|--------|--|--------|--------|
| KUOTA E TOKES | | | 966.15 | 966.49 | 966.60 | 966.79 | | | 966.57 |
| DIST. PJESORE E TOKES | | 6.5 | | 1.8 | 0.7 | 1.4 | | 4.5 | |
| KUOTA E PROJEKTIT | | | 966.26 | 966.75 | | 966.82 | | 966.75 | 966.74 |
| DIST. PJESORE E PROJEKTIT | | | 0.5 | 2.5 | | 2.5 | | | |

SEKSIONI NR. : 194
 KUOTA PROJEKTIT : 970.982
 PROGRESIVA : 4825.000

SEKSIONI NR. : 196
 KUOTA PROJEKTIT : 964.429
 PROGRESIVA : 4875.000

SHKALLA 1:100

SHKALLA 1:100

KUOTA REF. 969.271

KUOTA REF. 961.722

| | | | | | | | | | |
|---------------------------|--------|--------|--------|--------|--------|--------|--------|--------|--------|
| KUOTA E TOKES | 972.25 | | | 970.52 | 970.54 | 970.54 | 970.54 | | 970.08 |
| DIST. PJESORE E TOKES | 4.5 | | | 1.7 | 0.5 | 1.7 | 1.7 | | |
| KUOTA E PROJEKTIT | | 970.76 | 970.42 | | 970.48 | | 970.42 | 970.28 | |
| DIST. PJESORE E PROJEKTIT | | 0.3 | 2.5 | 2.5 | | | | | |

| | | | | | | | | | |
|---------------------------|--|--------|--------|--------|--------|--------|--------|-----|--------|
| KUOTA E TOKES | | 962.87 | | 963.75 | 963.74 | 963.86 | 964.05 | | 965.38 |
| DIST. PJESORE E TOKES | | 3.9 | | 1.1 | 1.1 | 1.7 | | 4.1 | |
| KUOTA E PROJEKTIT | | | 963.62 | 963.87 | | | | 2.5 | |
| DIST. PJESORE E PROJEKTIT | | | 0.2 | | | | | | |



BASHKIA LIBOHOVE
 OBJEKTI:
 RIPARIMIN DHE ASFALTIM I RRUGËS
 AUTOMOBILIS TIKE FUSHA E ÇAJUPIT – TOPOVË,
 PJESË E UNAZËS SË ZAGORISË L= 8971 ML.

EMERTIMI I FLETES:
 PROFIL TERTHOR

HARTOI: SEKTORI SHERBIMIT URBAN
 ARK. NELSON SEJDO

Data:
 06/2024
 SHK
 1:1000
 Nr. fleta
 49

SEKSIONI NR. : 197
 KUOTA PROJEKTIT : 962.892
 PROGRESIVA : 4900.000

SEKSIONI NR. : 199
 KUOTA PROJEKTIT : 957.806
 PROGRESIVA : 4950.000

SHKALLA 1:100

SHKALLA 1:100

KUOTA REF. 960.250

KUOTA REF. 955.397

| | | | | | | |
|---------------------------|--------|--------|--------|--------|--------|--------|
| KUOTA E TOKES | 961.74 | 962.13 | 962.21 | 962.21 | 962.38 | 962.64 |
| DIST. PJESORE E TOKES | 4.1 | 0.7 | 1.2 | 1.9 | 7.5 | |
| KUOTA E PROJEKTIT | | 962.06 | 962.33 | 962.39 | 962.33 | |
| DIST. PJESORE E PROJEKTIT | | 0.3 | 2.5 | 2.5 | | |

| | | | | | | |
|---------------------------|--------|--------|--------|--------|--------|--------|
| KUOTA E TOKES | 957.04 | 957.01 | 957.08 | 957.09 | 957.53 | 958.12 |
| DIST. PJESORE E TOKES | 3.8 | 1.2 | 2.2 | 3.2 | | |
| KUOTA E PROJEKTIT | | 957.02 | 957.24 | 957.31 | 957.24 | |
| DIST. PJESORE E PROJEKTIT | | 0.2 | 2.5 | 2.5 | | |

SEKSIONI NR. : 198
 KUOTA PROJEKTIT : 960.967
 PROGRESIVA : 4925.000

SEKSIONI NR. : 200
 KUOTA PROJEKTIT : 954.975
 PROGRESIVA : 4975.000

SHKALLA 1:100

SHKALLA 1:100

KUOTA REF. 958.781

KUOTA REF. 951.870

| | | | | | |
|---------------------------|--------|--------|--------|--------|--------|
| KUOTA E TOKES | 960.15 | 960.52 | 960.55 | 960.71 | 961.90 |
| DIST. PJESORE E TOKES | 5.1 | 1.8 | 1.1 | 4.1 | 2.6 |
| KUOTA E PROJEKTIT | 960.13 | 960.40 | 960.47 | 960.40 | |
| DIST. PJESORE E PROJEKTIT | 0.3 | 2.5 | 2.5 | | |

| | | | | | | |
|---------------------------|--------|--------|--------|--------|--------|--------|
| KUOTA E TOKES | 954.15 | 954.14 | 954.20 | 954.32 | 954.37 | 954.70 |
| DIST. PJESORE E TOKES | 1.7 | 0.8 | 1.8 | 0.5 | 1.2 | 5.9 |
| KUOTA E PROJEKTIT | 954.13 | 954.41 | | | | |
| DIST. PJESORE E PROJEKTIT | 0.3 | 2.5 | | | | |



BASHKIA LIBOHOVE

OBJEKTI:
 RIPARIMIN DHE ASFALTIM I RRUGËS
 AUTOMOBILIS TIKE FUSHA E ÇAJUPIT – TOPOVË,
 PJESË E UNAZËS SË ZAGORISË L= 8971 ML.

Data:
 06/2024

EMERTIMI I FLETES:

PROFIL TERTHOR

SHK
 1:1000

HARTOI: SEKTORI SHERBIMIT URBAN
 ARK. NELSON SEJDO

Nr. fleta
 50

SEKSIONI NR. : 201
 KUOTA PROJEKTIT : 952.969
 PROGRESIVA : 5000.000

SHKALLA 1:100

KUOTA REF. 949.828

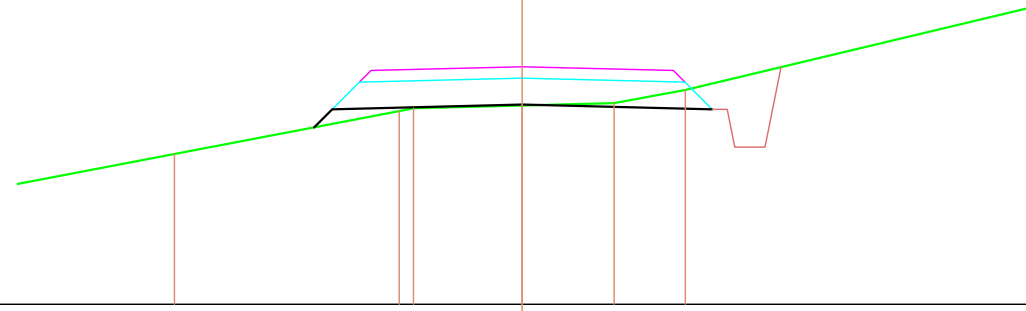

| | | | | | | | |
|---------------------------|--------|------------------|--------|--------|--------|-----|-----|
| KUOTA E TOKES | 951.81 | 952.38 952.72 | 952.46 | 952.79 | 952.66 | | |
| DIST. PJESORE E TOKES | | 3.0 | 0.2 | 1.4 | 1.2 | 0.9 | 5.3 |
| KUOTA E PROJEKTIT | | 952.17 952.41 | 952.47 | | 952.41 | | |
| DIST. PJESORE E PROJEKTIT | | 0.2 | 2.5 | | 2.5 | | |

SEKSIONI NR. : 203
 KUOTA PROJEKTIT : 950.123
 PROGRESIVA : 5050.000

SHKALLA 1:100

KUOTA REF. 948.452

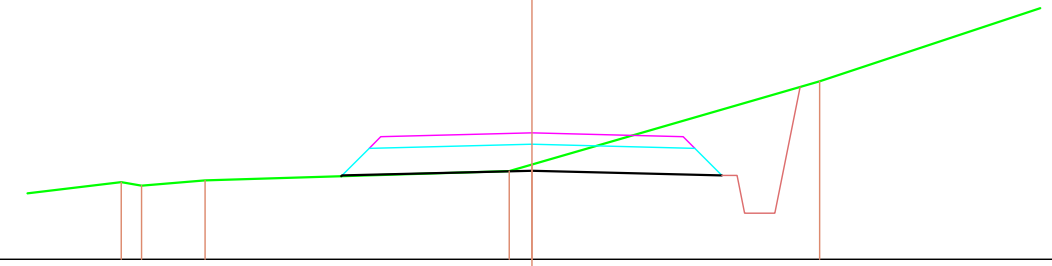

| | | | | | | |
|---------------------------|------------------|--------|------------------|--------|--------|--|
| KUOTA E TOKES | 949.47 949.73 | 949.49 | 949.62 949.71 | 950.80 | | |
| DIST. PJESORE E TOKES | 0.3 | 0.8 | 4.0 | 0.3 | 3.8 | |
| KUOTA E PROJEKTIT | 949.55 949.56 | | 949.62 | | 949.56 | |
| DIST. PJESORE E PROJEKTIT | | | 2.5 | | 2.5 | |

SEKSIONI NR. : 202
 KUOTA PROJEKTIT : 951.145
 PROGRESIVA : 5025.000

SHKALLA 1:100

KUOTA REF. 949.154

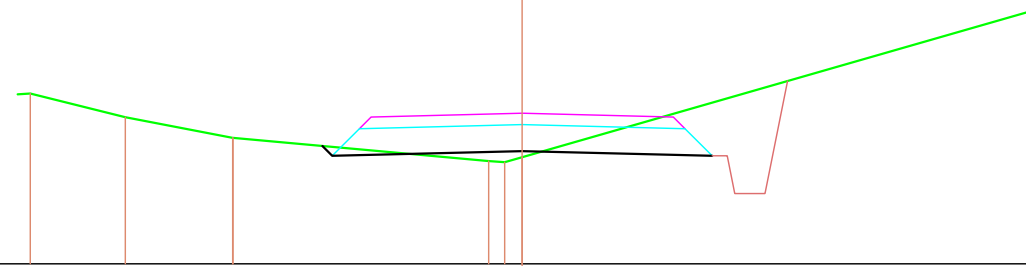

| | | | | | | | |
|---------------------------|--------|--------|------------------|----------------------------|-----|--------|------|
| KUOTA E TOKES | 951.41 | 951.09 | 950.82 950.82 | 950.51 950.50 950.50 | | | |
| DIST. PJESORE E TOKES | | 1.3 | 1.4 | 3.4 | 0.2 | 0.2 | 10.3 |
| KUOTA E PROJEKTIT | | | 950.71 950.58 | 950.65 | | 950.58 | |
| DIST. PJESORE E PROJEKTIT | | | | 2.5 | | 2.5 | |

SEKSIONI NR. : 204
 KUOTA PROJEKTIT : 948.255
 PROGRESIVA : 5075.000

SHKALLA 1:100

KUOTA REF. 946.317

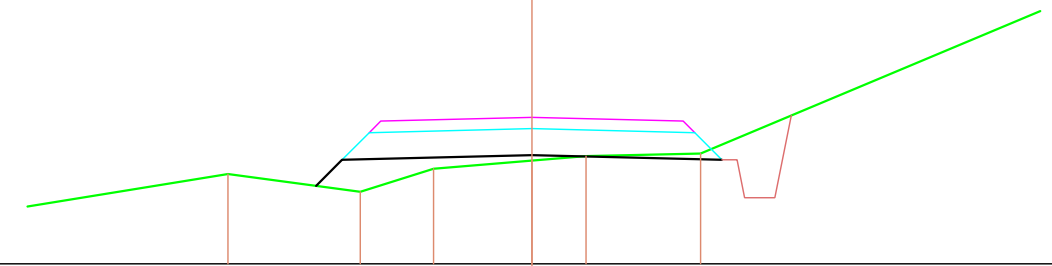

| | | | | | | | |
|---------------------------|--------|------------------|--------|--------|--------|--------|-----|
| KUOTA E TOKES | 947.50 | 947.27 | 947.57 | 947.68 | 947.74 | 947.78 | |
| DIST. PJESORE E TOKES | | 1.8 | 1.0 | 1.3 | 0.7 | 1.5 | 5.5 |
| KUOTA E PROJEKTIT | | 947.35 947.69 | | | | | |
| DIST. PJESORE E PROJEKTIT | | | 0.3 | | 2.5 | | |



| | |
|---|------------------|
| BASHKIA LIBOHOVE | |
| OBJEKTI: RIPARIMIN DHE ASFALTIM I RRUGËS AUTOMOBILIS TIKE FUSHA E ÇAJUPIT – TOPOVË, PJESË E UNAZËS SË ZAGORISË L= 8971 ML. | Data: 06/2024 |
| EMERTIMI I FLETES: PROFIL TERTHOR | SHK 1:1000 |
| HARTOI: SEKTORI SHERBIMIT URBAN ARK. NELSON SEJDO | Nr. fleta 51 |

SEKSIONI NR. : 205
 KUOTA PROJEKTIT : 946.387
 PROGRESIVA : 5100.000

SHKALLA 1:100

KUOTA REF. 943.855

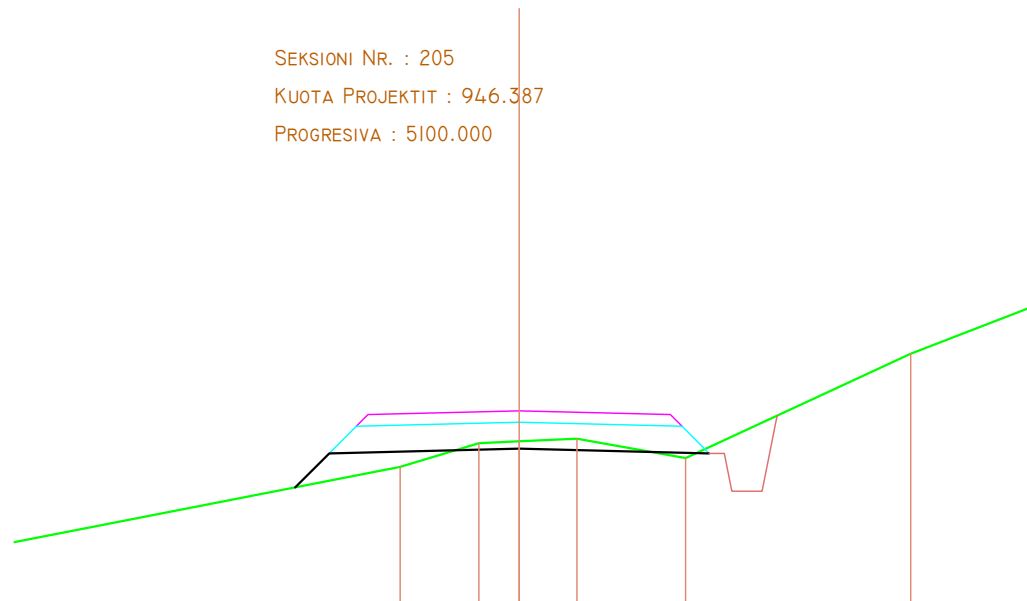

| | | | | | | | |
|---------------------------|-----|--------|--------|--------|--------|--------|--------|
| KUOTA E TOKES | | 945.65 | 945.96 | 945.98 | 946.02 | 945.76 | 947.14 |
| DIST. PJESORE E TOKES | 7.2 | | 1.0 | 0.5 | 0.8 | 1.4 | 3.0 |
| KUOTA E PROJEKTIT | | 945.37 | 945.82 | 945.89 | | 945.82 | |
| DIST. PJESORE E PROJEKTIT | | 0.4 | 2.5 | | 2.5 | | |

SEKSIONI NR. : 207
 KUOTA PROJEKTIT : 942.651
 PROGRESIVA : 5150.000

SHKALLA 1:100

KUOTA REF. 940.040

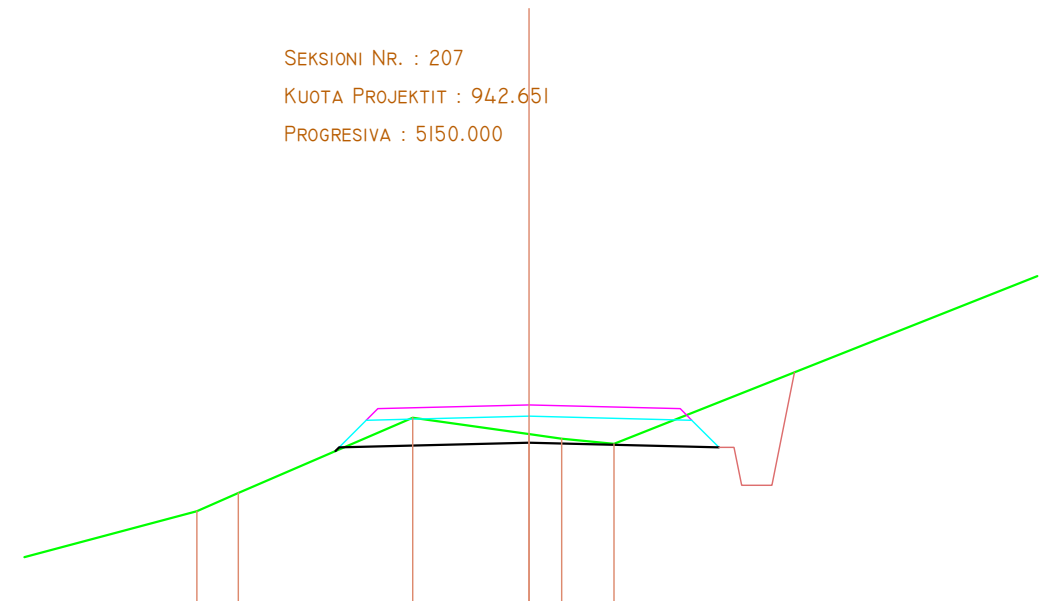

| | | | | | | | |
|---------------------------|--|--------|--------|--------|--------|--------|--------|
| KUOTA E TOKES | | 941.24 | 941.49 | 942.48 | 942.26 | 942.20 | 942.14 |
| DIST. PJESORE E TOKES | | 0.5 | 2.3 | 1.5 | 0.4 | 0.7 | 11.2 |
| KUOTA E PROJEKTIT | | 942.04 | 942.09 | | 942.15 | | 942.09 |
| DIST. PJESORE E PROJEKTIT | | | | 2.5 | | 2.5 | |

SEKSIONI NR. : 206
 KUOTA PROJEKTIT : 944.519
 PROGRESIVA : 5125.000

SHKALLA 1:100

KUOTA REF. 941.814

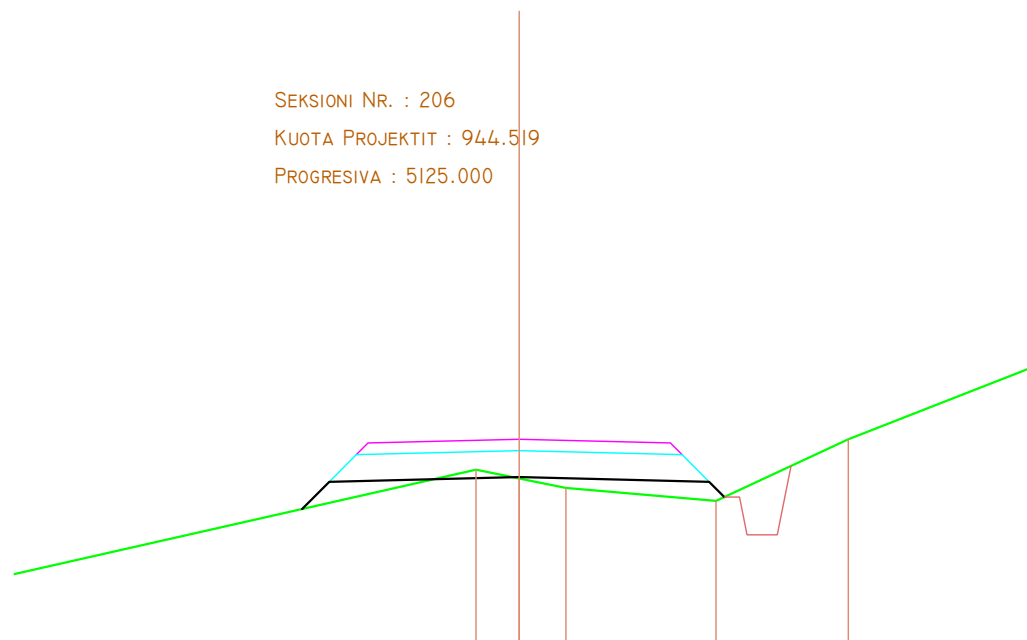

| | | | | | | |
|---------------------------|--|--------|--------|--------|--------|--------|
| KUOTA E TOKES | | 944.12 | 944.00 | 943.87 | 943.70 | 944.52 |
| DIST. PJESORE E TOKES | | 0.6 | 0.6 | 2.0 | 1.7 | |
| KUOTA E PROJEKTIT | | 943.60 | 943.96 | 944.02 | 943.96 | 943.75 |
| DIST. PJESORE E PROJEKTIT | | 0.4 | 2.5 | | 2.5 | 0.2 |

SEKSIONI NR. : 208
 KUOTA PROJEKTIT : 940.737
 PROGRESIVA : 5175.000

SHKALLA 1:100

KUOTA REF. 937.583

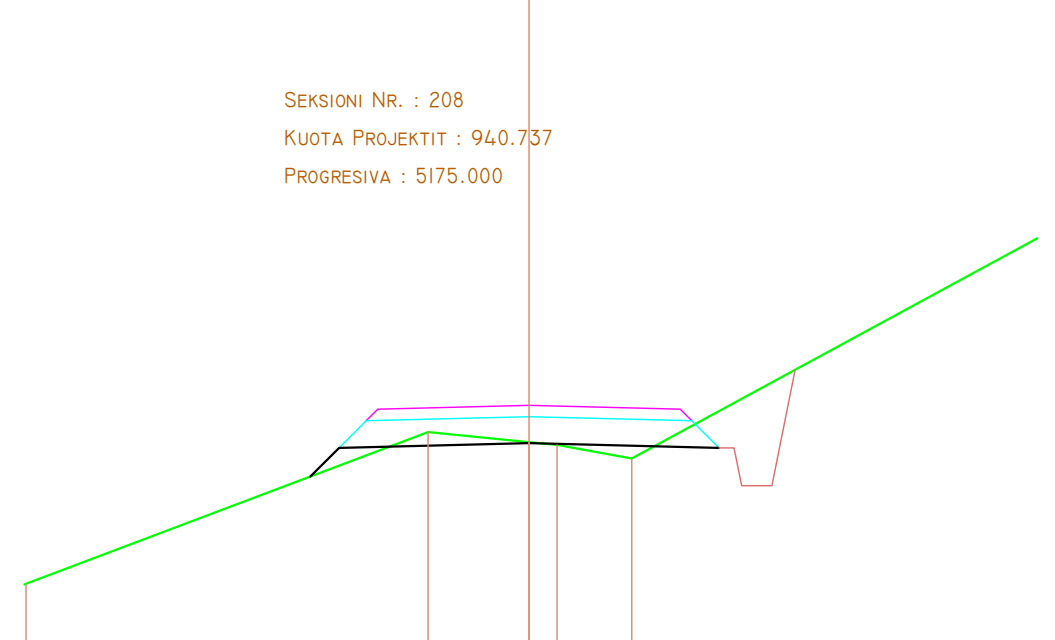

| | | | | | | |
|---------------------------|--|--------|--------|--------|--------|--------|
| KUOTA E TOKES | | 938.38 | 940.38 | 940.25 | 940.21 | 940.03 |
| DIST. PJESORE E TOKES | | 5.3 | 1.3 | 0.4 | 1.0 | 6.5 |
| KUOTA E PROJEKTIT | | 939.79 | 940.17 | | | |
| DIST. PJESORE E PROJEKTIT | | 0.4 | 2.5 | | | |



BASHKIA LIBOHOVE
 OBJEKTI:
 RIPARIMIN DHE ASFALTIM I RRUGËS
 AUTOMOBILIS TIKE FUSHA E ÇAJUPIT – TOPOVË,
 PJESË E UNAZËS SË ZAGORISË L= 8971 ML.

Data:
06/2024

EMERTIMI I FLETES:
 PROFIL TERTHOR

SHK
1:1000

HARTOI: SEKTORI SHERBIMIT URBAN
 ARK. NELSON SEJDO

Nr. fleta
52

SEKSIONI NR. : 209
 KUOTA PROJEKTIT : 938.519
 PROGRESIVA : 5200.000

SEKSIONI NR. : 211
 KUOTA PROJEKTIT : 933.916
 PROGRESIVA : 5250.000

SHKALLA 1:100

SHKALLA 1:100

KUOTA REF. 935.265

KUOTA REF. 931.284

| | | | | | | |
|---------------------------|-----|--------|--------|--------|--------|--------|
| KUOTA E TOKES | | 937.68 | 937.46 | 937.10 | 937.10 | 937.26 |
| DIST. PJESORE E TOKES | 7.2 | 1.3 | 2.1 | 0.3 | | |
| KUOTA E PROJEKTIT | | 937.26 | 937.96 | 938.02 | 937.96 | 937.46 |
| DIST. PJESORE E PROJEKTIT | | 0.7 | 2.5 | 2.5 | 0.5 | |

| | | | | | |
|---------------------------|--|--------|--------|--------|--------|
| KUOTA E TOKES | | 933.33 | 933.38 | 933.59 | 933.50 |
| DIST. PJESORE E TOKES | | 2.3 | 0.2 | 1.3 | 5.4 |
| KUOTA E PROJEKTIT | | 933.21 | 933.35 | 933.42 | 933.35 |
| DIST. PJESORE E PROJEKTIT | | 2.5 | | 2.5 | |

SEKSIONI NR. : 210
 KUOTA PROJEKTIT : 936.297
 PROGRESIVA : 5225.000

SEKSIONI NR. : 212
 KUOTA PROJEKTIT : 930.557
 PROGRESIVA : 5275.000

SHKALLA 1:100

SHKALLA 1:100

KUOTA REF. 934.141

KUOTA REF. 928.606

| | | | | | | |
|---------------------------|-----|--------|--------|--------|--------|--------|
| KUOTA E TOKES | | 935.80 | 935.88 | 935.87 | 935.78 | 938.71 |
| DIST. PJESORE E TOKES | 5.3 | 1.5 | 0.2 | 1.5 | 4.2 | |
| KUOTA E PROJEKTIT | | 935.59 | 935.73 | 935.80 | 935.73 | |
| DIST. PJESORE E PROJEKTIT | | 2.5 | | 2.5 | | |

| | | | | | | | |
|---------------------------|--|--------|--------|--------|--------|--------|--------|
| KUOTA E TOKES | | 930.04 | 930.08 | 930.05 | 930.10 | 930.25 | 930.29 |
| DIST. PJESORE E TOKES | | 1.6 | 0.2 | 2.6 | | 1.2 | 6.9 |
| KUOTA E PROJEKTIT | | | 930.11 | 929.99 | | | |
| DIST. PJESORE E PROJEKTIT | | | 2.5 | | | | |



BASHKIA LIBOHOVE

OBJEKTI:
 RIPARIMIN DHE ASFALTIM I RRUGËS
 AUTOMOBILIS TIKE FUSHA E ÇAJUPIT – TOPOVË,
 PJESË E UNAZËS SË ZAGORISË L= 8971 ML.

Data:

06/2024

EMERTIMI I FLETES:

PROFIL TERTHOR

SHK
 1:1000

HARTOI: SEKTORI SHERBIMIT URBAN
 ARK. NELSON SEJDO

Nr. fleta

53

SEKSIONI NR. : 213
 KUOTA PROJEKTIT : 926.872
 PROGRESIVA : 5300.000

SHKALLA 1:100

KUOTA REF. 924.155

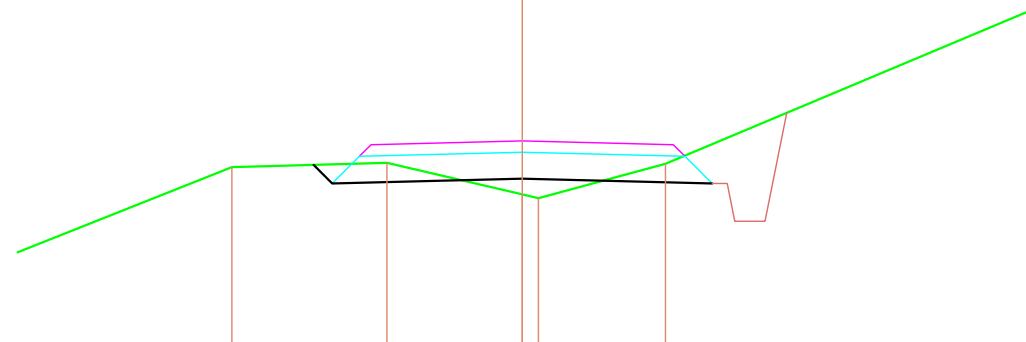

| | | | | |
|---------------------------|--------|------------------|------------------|------------|
| KUOTA E TOKES | 926.52 | 926.58 | 926.16 926.11 | 926.57 |
| DIST. PJESORE E TOKES | 4.0 | 2.1 | 1.8 0.2 | 1.7 9.6 |
| KUOTA E PROJEKTIT | | 926.56 926.31 | 926.37 | 926.31 |
| DIST. PJESORE E PROJEKTIT | | 0.2 | 2.5 | 2.5 |

SEKSIONI NR. : 215
 KUOTA PROJEKTIT : 919.600
 PROGRESIVA : 5350.000

SHKALLA 1:100

KUOTA REF. 916.755

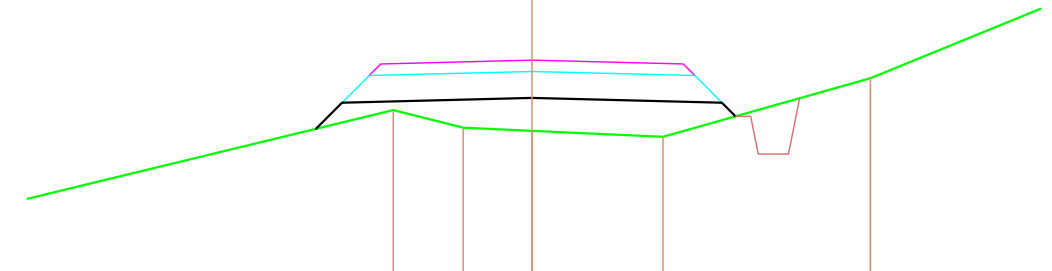

| | | | | | |
|---------------------------|------------------|--------|--------|--------|------------------|
| KUOTA E TOKES | 918.94 | 918.71 | 918.67 | 918.59 | 919.36 |
| DIST. PJESORE E TOKES | | 0.9 | 0.9 | 1.7 | 2.7 |
| KUOTA E PROJEKTIT | 918.69 919.04 | | 919.10 | | 919.04 918.86 |
| DIST. PJESORE E PROJEKTIT | 0.3 | 2.5 | | 2.5 | 0.2 |

SEKSIONI NR. : 214
 KUOTA PROJEKTIT : 923.186
 PROGRESIVA : 5325.000

SHKALLA 1:100

KUOTA REF. 920.166

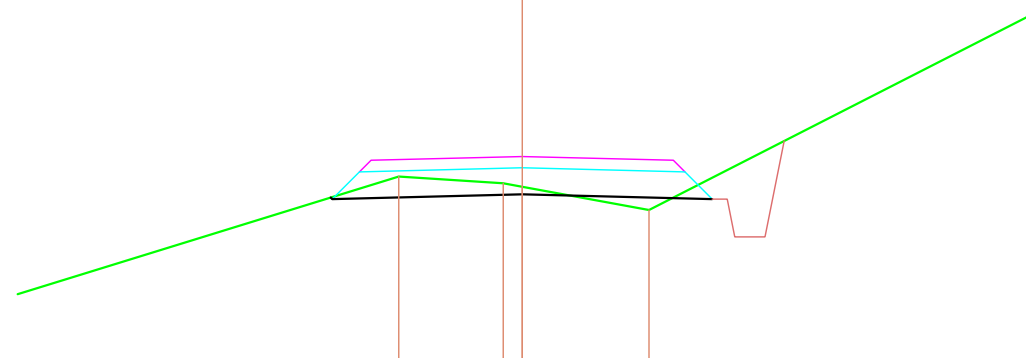

| | | | |
|---------------------------|------------------|------------------|------------|
| KUOTA E TOKES | 922.92 | 922.85 922.79 | 922.48 |
| DIST. PJESORE E TOKES | 5.2 | 1.4 0.3 | 1.7 5.6 |
| KUOTA E PROJEKTIT | 922.64 922.62 | 922.69 | 922.62 |
| DIST. PJESORE E PROJEKTIT | | 2.5 | 2.5 |

SEKSIONI NR. : 216
 KUOTA PROJEKTIT : 917.275
 PROGRESIVA : 5375.000

SHKALLA 1:100

KUOTA REF. 914.423

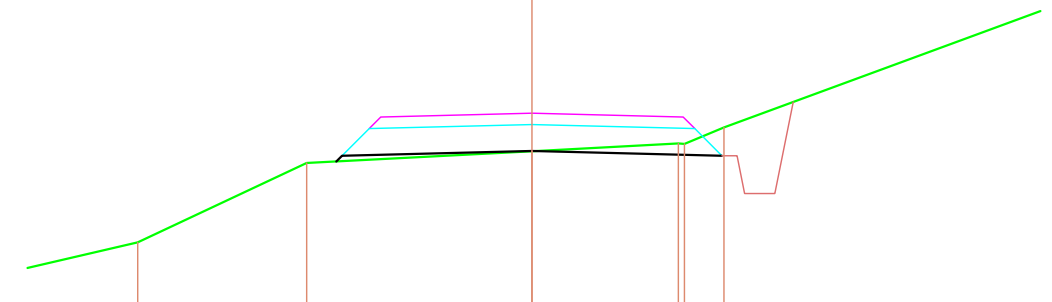

| | | | | | |
|---------------------------|--------|------------------|--------|------------------|--------|
| KUOTA E TOKES | 915.57 | 916.62 | 916.77 | 916.87 916.87 | 917.09 |
| DIST. PJESORE E TOKES | | 2.2 | 3.0 | 1.9 | 0.5 |
| KUOTA E PROJEKTIT | | 916.64 916.71 | | | |
| DIST. PJESORE E PROJEKTIT | | | 2.5 | | |



BASHKIA LIBOHOVE

OBJEKTI:
 RIPARIMIN DHE ASFALTIM I RRUGËS
 AUTOMOBILIS TIKE FUSHA E ÇAJUPIT – TOPOVË,
 PJESE E UNAZËS SË ZAGORISË L= 8971 ML.

Data:
 06/2024

EMERTIMI I FLETES:
 PROFIL TERTHOR

SHK
 1:1000

HARTOI: SEKTORI SHERBIMIT URBAN
 ARK. NELSON SEJDO

Nr. fleta
 54

SEKSIONI NR. : 217
 KUOTA PROJEKTIT : 914.394
 PROGRESIVA : 5400.000

SHKALLA 1:100

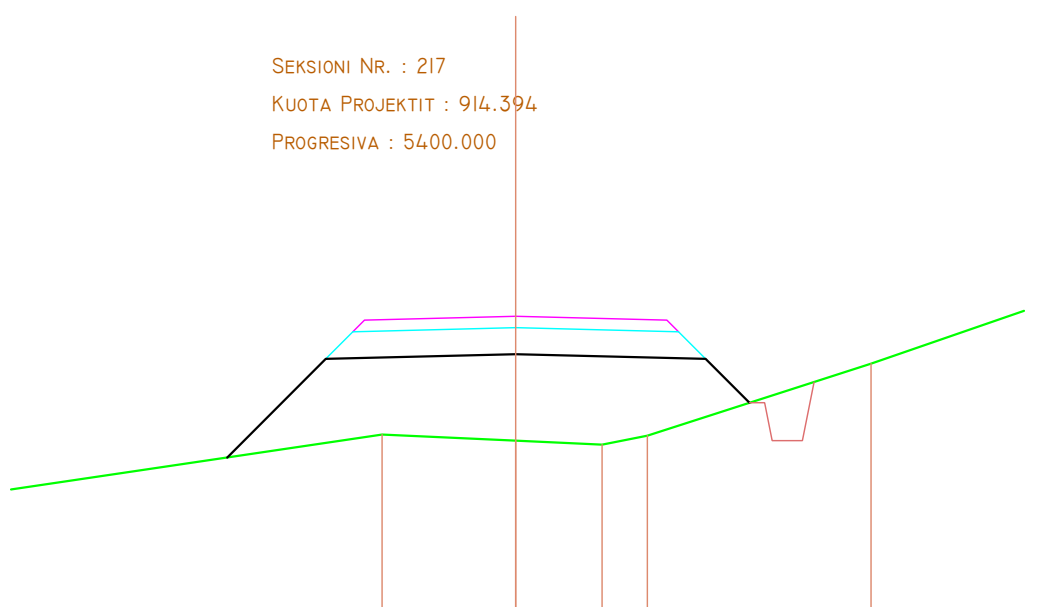

KUOTA REF. 910.509

| | | | | | | |
|---------------------------|-----|--------|--------|--------|--------|--------|
| KUOTA E TOKES | | 912.83 | 912.75 | 912.70 | 912.82 | 913.77 |
| DIST. PJESORE E TOKES | 6.5 | 1.8 | 1.1 | 0.6 | 3.0 | |
| KUOTA E PROJEKTIT | | 912.53 | 913.83 | 913.89 | 913.83 | 913.25 |
| DIST. PJESORE E PROJEKTIT | | 1.3 | 2.5 | 2.5 | 0.6 | |

SEKSIONI NR. : 219
 KUOTA PROJEKTIT : 908.256
 PROGRESIVA : 5450.000

SHKALLA 1:100

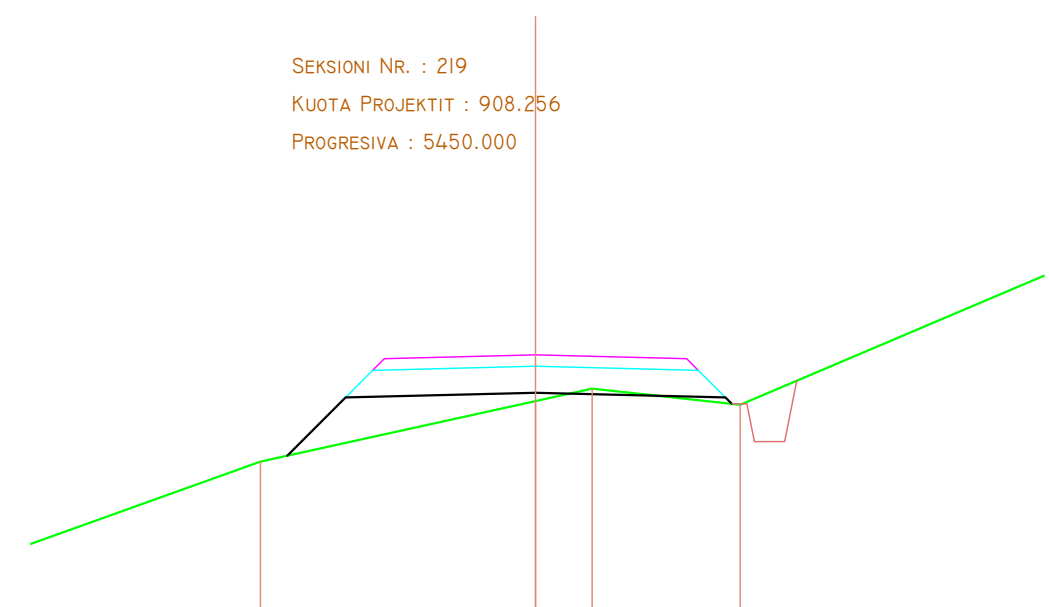

KUOTA REF. 904.881

| | | | | | |
|---------------------------|--|--------|--------|--------|--------|
| KUOTA E TOKES | | 906.84 | 907.65 | 907.81 | 907.60 |
| DIST. PJESORE E TOKES | | 3.6 | 0.7 | 2.0 | |
| KUOTA E PROJEKTIT | | 906.92 | 907.69 | 907.76 | 907.69 |
| DIST. PJESORE E PROJEKTIT | | 0.8 | 2.5 | 2.5 | |

SEKSIONI NR. : 218
 KUOTA PROJEKTIT : 911.325
 PROGRESIVA : 5425.000

SHKALLA 1:100

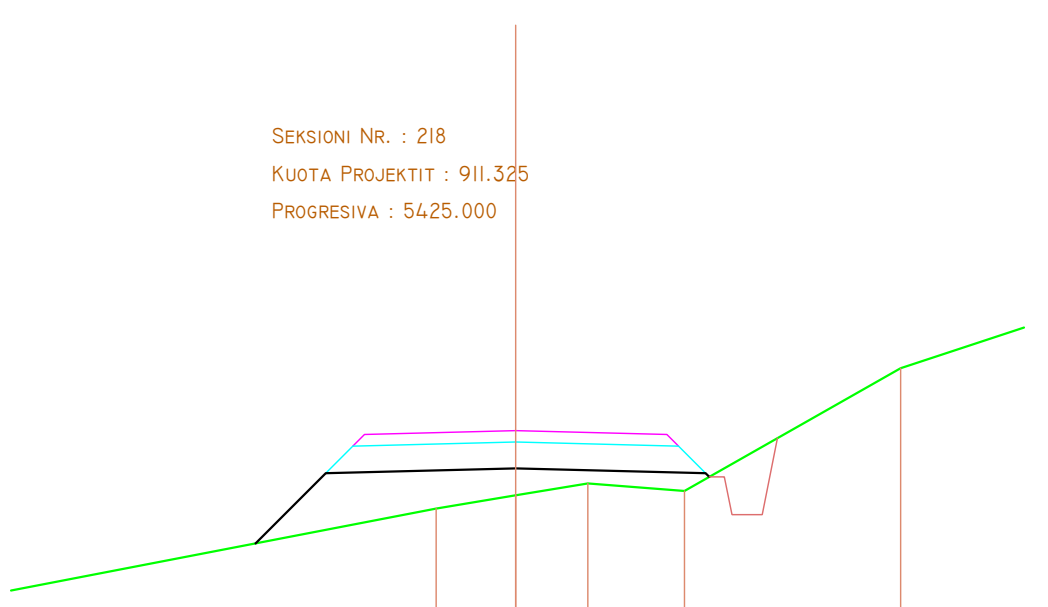

KUOTA REF. 908.032

| | | | | | | |
|---------------------------|-----|--------|--------|--------|--------|--------|
| KUOTA E TOKES | | 910.29 | 910.47 | 910.63 | 910.53 | 912.15 |
| DIST. PJESORE E TOKES | 8.7 | 1.1 | 1.0 | 1.3 | 2.9 | 2.0 |
| KUOTA E PROJEKTIT | | 909.83 | 910.76 | 910.82 | 910.76 | 910.71 |
| DIST. PJESORE E PROJEKTIT | | 0.9 | 2.5 | 2.5 | | |

SEKSIONI NR. : 220
 KUOTA PROJEKTIT : 905.187
 PROGRESIVA : 5475.000

SHKALLA 1:100

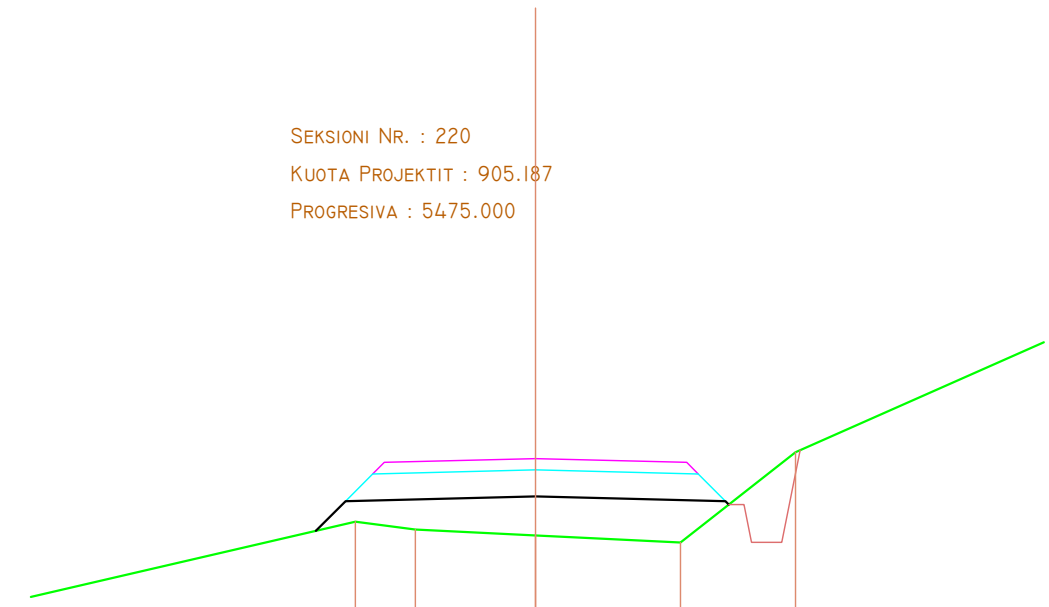

KUOTA REF. 902.264

| | | | | | | |
|---------------------------|-----|--------|--------|--------|--------|--------|
| KUOTA E TOKES | | 904.35 | 904.25 | 904.17 | 904.08 | 905.27 |
| DIST. PJESORE E TOKES | 5.1 | 0.8 | 1.6 | | | |
| KUOTA E PROJEKTIT | | 904.23 | 904.62 | | | |
| DIST. PJESORE E PROJEKTIT | | 0.4 | 2.5 | | | |



BASHKIA LIBOHOVE

OBJEKTI:
 RIPARIMIN DHE ASFALTIM I RRUGËS
 AUTOMOBILIS TIKE FUSHA E ÇAJUPIT – TOPOVË,
 PJESË E UNAZËS SË ZAGORISË L= 8971 ML.

EMERTIMI I FLETES:
 PROFIL TERTHOR

HARTOI: SEKTORI SHERBIMIT URBAN
 ARK. NELSON SEJDO

Data:
 06/2024

SHK
 1:1000

Nr. fleta
 55

SEKSIONI NR. : 221
 KUOTA PROJEKTIT : 902.361
 PROGRESIVA : 5500.000

SEKSIONI NR. : 223
 KUOTA PROJEKTIT : 898.819
 PROGRESIVA : 5550.000

SHKALLA 1:100

SHKALLA 1:100

KUOTA REF. 899.498

KUOTA REF. 894.380

| | | | | | | | |
|---------------------------|------------------|--------|--------|--------|--------|--------|--|
| KUOTA E TOKES | 901.01 | 901.55 | 901.39 | 901.47 | 901.59 | 902.13 | |
| DIST. PJESORE E TOKES | 2.3 | 1.2 | 1.1 | 1.6 | 1.7 | 4.3 | |
| KUOTA E PROJEKTIT | 901.43 901.80 | | | 901.86 | | 901.80 | |
| DIST. PJESORE E PROJEKTIT | 0.4 | 2.5 | | 2.5 | | | |

| | | | | | | | |
|---------------------------|------------------|--------|--------|--------|--------|------------------|--|
| KUOTA E TOKES | 898.43 | 898.54 | 898.31 | 898.24 | 897.72 | 898.44 | |
| DIST. PJESORE E TOKES | 1.5 | 0.5 | 0.3 | 2.3 | 2.6 | | |
| KUOTA E PROJEKTIT | 898.34 898.26 | | | 898.32 | | 898.26 897.89 | |
| DIST. PJESORE E PROJEKTIT | | 2.5 | | 2.5 | 0.4 | | |

SEKSIONI NR. : 222
 KUOTA PROJEKTIT : 900.521
 PROGRESIVA : 5525.000

SEKSIONI NR. : 224
 KUOTA PROJEKTIT : 897.117
 PROGRESIVA : 5575.000

SHKALLA 1:100

SHKALLA 1:100

KUOTA REF. 896.640

KUOTA REF. 894.823

| | | | | | |
|---------------------------|------------------|--------|--------|--------|-----|
| KUOTA E TOKES | 900.15 | 900.15 | 900.15 | 900.26 | |
| DIST. PJESORE E TOKES | 6.8 | 2.1 | 0.7 | 1.5 | 6.3 |
| KUOTA E PROJEKTIT | 899.92 899.96 | | 900.02 | 899.96 | |
| DIST. PJESORE E PROJEKTIT | | 2.5 | | 2.5 | |

| | | | | | |
|---------------------------|------------------|--------|--------|--------|--|
| KUOTA E TOKES | 896.00 | 895.95 | 895.95 | 895.95 | |
| DIST. PJESORE E TOKES | 5.7 | 0.4 | 1.5 | | |
| KUOTA E PROJEKTIT | 895.91 896.55 | | | | |
| DIST. PJESORE E PROJEKTIT | 0.6 | 2.5 | | | |

BASHKIA LIBOHOVE

OBJEKTI:
 RIPARIMIN DHE ASFALTIM I RRUGËS
 AUTOMOBILIS TIKE FUSHA E ÇAJUPIT – TOPOVË,
 PJESË E UNAZËS SË ZAGORISË L= 8971 ML.

EMERTIMI I FLETES:
 PROFIL TERTHOR

HARTOI: SEKTORI SHERBIMIT URBAN
 ARK. NELSON SEJDO

Data:
 06/2024

SHK
 1:1000

Nr. fleta
 56

SEKSIONI NR. : 225
 KUOTA PROJEKTIT : 895.402
 PROGRESIVA : 5600.000

SEKSIONI NR. : 227
 KUOTA PROJEKTIT : 890.714
 PROGRESIVA : 5650.000

SHKALLA 1:100

SHKALLA 1:100

KUOTA REF. 893.013

KUOTA REF. 888.988

| | | | | | | |
|---------------------------|-----|------------------|--------|--------|--------|--------|
| KUOTA E TOKES | | 894.96 | 894.87 | 894.81 | 894.53 | 896.60 |
| DIST. PJESORE E TOKES | 9.1 | 1.2 | 0.8 | 1.3 | 2.4 | |
| KUOTA E PROJEKTIT | | 894.56 894.84 | 894.90 | 894.84 | | |
| DIST. PJESORE E PROJEKTIT | | 0.3 | 2.5 | 2.5 | | |

| | | | | | | |
|---------------------------|--|------------------|--------|------------------|--------|--------|
| KUOTA E TOKES | | 889.51 | 889.72 | 889.49 889.51 | 889.95 | 891.40 |
| DIST. PJESORE E TOKES | | 1.4 | 1.1 | 1.7 | 1.4 | 5.2 |
| KUOTA E PROJEKTIT | | 889.36 890.15 | 890.21 | 890.15 | | |
| DIST. PJESORE E PROJEKTIT | | 0.8 | 2.5 | 2.5 | | |

SEKSIONI NR. : 226
 KUOTA PROJEKTIT : 892.921
 PROGRESIVA : 5625.000

SEKSIONI NR. : 228
 KUOTA PROJEKTIT : 890.062
 PROGRESIVA : 5675.000

SHKALLA 1:100

SHKALLA 1:100

KUOTA REF. 891.050

KUOTA REF. 887.293

| | | | | | | | |
|---------------------------|--|------------------|--------|------------------|--------|--------|--------|
| KUOTA E TOKES | | 891.77 | 892.37 | 892.64 | 892.60 | 892.50 | 892.03 |
| DIST. PJESORE E TOKES | | 2.2 | 1.1 | 0.6 | 0.4 | 2.1 | 4.9 |
| KUOTA E PROJEKTIT | | 892.22 892.36 | 892.42 | 892.36 892.34 | | | |
| DIST. PJESORE E PROJEKTIT | | | 2.5 | 2.5 | | | |

| | | | | | | | |
|---------------------------|-----|------------------|--------|---|--------|--------|--------|
| KUOTA E TOKES | | 889.96 | 889.60 | 889.56 | 889.52 | 889.31 | 889.70 |
| DIST. PJESORE E TOKES | 7.0 | 1.5 | 1.1 | BASHKIA LIBOHOVE | | | |
| KUOTA E PROJEKTIT | | 889.85 889.50 | | | | | |
| DIST. PJESORE E PROJEKTIT | | 0.4 | 2.5 | OBJEKTI: RIPARIMIN DHE ASFALTIM I RRUGËS AUTOMOBILIS TIKE FUSHA E ÇAJUPIT – TOPOVË, PJESË E UNAZËS SË ZAGORISË L= 8971 ML. | | | |

| | | |
|---|--|------------------|
|  | EMERTIMI I FLETES: PROFIL TERTHOR | Data: 06/2024 |
| | HARTOI: SEKTORI SHERBIMIT URBAN ARK. NELSON SEJDO | |
| | Nr. fleta 57 | |

SEKSIONI NR. : 229
 KUOTA PROJEKTIT : 890.256
 PROGRESIVA : 5700.000

SEKSIONI NR. : 231
 KUOTA PROJEKTIT : 890.647
 PROGRESIVA : 5750.000

SHKALLA 1:100

SHKALLA 1:100

KUOTA REF. 887.920

KUOTA REF. 888.156

| | | | | | | | |
|---------------------------|-----|--------|--------|--------|--------|--------|--------|
| KUOTA E TOKES | | 889.39 | 889.28 | 889.12 | 889.14 | 889.60 | |
| DIST. PJESORE E TOKES | 7.2 | | 1.0 | 1.4 | 0.2 | 0.9 | 6.3 |
| KUOTA E PROJEKTIT | | 888.88 | 889.69 | 889.76 | | 889.69 | 889.62 |
| DIST. PJESORE E PROJEKTIT | | 0.8 | 2.5 | 2.5 | | | |

| | | | | | | | | |
|---------------------------|--|--------|--------|--------|--------|--------|--------|------|
| KUOTA E TOKES | | 890.41 | 890.64 | 890.62 | 890.60 | 890.60 | 890.59 | |
| DIST. PJESORE E TOKES | | 3.2 | 0.5 | 0.7 | 0.4 | 1.6 | | 10.0 |
| KUOTA E PROJEKTIT | | 890.55 | 890.08 | | 890.15 | | 890.08 | |
| DIST. PJESORE E PROJEKTIT | | 0.5 | 2.5 | | 2.5 | | | |

SEKSIONI NR. : 230
 KUOTA PROJEKTIT : 890.452
 PROGRESIVA : 5725.000

SEKSIONI NR. : 232
 KUOTA PROJEKTIT : 890.664
 PROGRESIVA : 5775.000

SHKALLA 1:100

SHKALLA 1:100

KUOTA REF. 887.158

KUOTA REF. 887.781

| | | | | | | | |
|---------------------------|--|--------|--------|--------|--------|--------|--|
| KUOTA E TOKES | | 888.68 | 889.41 | 889.56 | 889.92 | 890.04 | |
| DIST. PJESORE E TOKES | | 2.7 | 0.5 | 1.3 | 0.5 | | |
| KUOTA E PROJEKTIT | | 888.57 | 889.89 | 889.95 | | 889.89 | |
| DIST. PJESORE E PROJEKTIT | | 1.3 | 2.5 | 2.5 | | | |

| | | | | | | | | |
|---------------------------|------|--------|--------|--------|--------|--------|--------|--|
| KUOTA E TOKES | | 890.43 | 890.49 | 890.63 | 890.49 | 890.09 | 890.37 | |
| DIST. PJESORE E TOKES | 11.6 | | | | | | | |
| KUOTA E PROJEKTIT | | 889.77 | 890.10 | | | | | |
| DIST. PJESORE E PROJEKTIT | | 0.3 | 2.5 | | | | | |



BASHKIA LIBOHOVE

OBJEKTI:
 RIPARIMIN DHE ASFALTIM I RRUGËS
 AUTOMOBILIS TIKE FUSHA E ÇAJUPIT – TOPOVË,
 PJESË E UNAZËS SË ZAGORISË L= 8971 ML.

Data:
 06/2024

EMERTIMI I FLETES:
 PROFIL TERTHOR

SHK
 1:1000

HARTOI: SEKTORI SHERBIMIT URBAN
 ARK. NELSON SEJDO

Nr. fleta
 58

SEKSIONI NR. : 233
 KUOTA PROJEKTIT : 889.792
 PROGRESIVA : 5800.000

SEKSIONI NR. : 235
 KUOTA PROJEKTIT : 886.165
 PROGRESIVA : 5850.000

SHKALLA 1:100

SHKALLA 1:100

KUOTA REF. 887.018

KUOTA REF. 883.572

| | | | | | |
|---------------------------|------------------|------------------|--------|------------------|--------|
| KUOTA E TOKES | 888.27 | 889.20 889.20 | 889.30 | 889.63 889.65 | 890.44 |
| DIST. PJESORE E TOKES | 4.5 | 0.5 | 1.7 | 2.4 | |
| KUOTA E PROJEKTIT | 888.71 889.23 | 889.29 | 889.23 | | |
| DIST. PJESORE E PROJEKTIT | 0.5 | 2.5 | 2.5 | | |

| | | | | | |
|---------------------------|--------|--------|------------------|--------|-----|
| KUOTA E TOKES | 883.57 | 885.36 | 885.35 885.36 | 885.38 | |
| DIST. PJESORE E TOKES | 5.5 | 0.8 | 0.3 | 1.1 | 5.7 |
| KUOTA E PROJEKTIT | 884.61 | 885.60 | 885.67 | 885.60 | |
| DIST. PJESORE E PROJEKTIT | 1.0 | 2.5 | 2.5 | | |

SEKSIONI NR. : 234
 KUOTA PROJEKTIT : 888.052
 PROGRESIVA : 5825.000

SEKSIONI NR. : 236
 KUOTA PROJEKTIT : 884.278
 PROGRESIVA : 5875.000

SHKALLA 1:100

SHKALLA 1:100

KUOTA REF. 885.286

KUOTA REF. 881.305

| | | | | |
|---------------------------|------------------|--------|------------------|------------|
| KUOTA E TOKES | 887.24 | 887.33 | 887.55 887.56 | 887.73 |
| DIST. PJESORE E TOKES | 10.3 | 0.7 | 1.9 | 0.2 0.4 |
| KUOTA E PROJEKTIT | 886.70 887.49 | 887.55 | 887.49 | |
| DIST. PJESORE E PROJEKTIT | 0.8 | 2.5 | 2.5 | |

| | | | | | |
|---------------------------|------------------|--------|------------------|--------|--------|
| KUOTA E TOKES | 883.47 | 883.35 | 883.66 883.67 | 885.05 | 885.76 |
| DIST. PJESORE E TOKES | 6.5 | 0.9 | 1.8 | | |
| KUOTA E PROJEKTIT | 883.45 883.72 | | | | |
| DIST. PJESORE E PROJEKTIT | 0.3 | 2.5 | | | |



BASHKIA LIBOHOVE
 OBJEKTI:
 RIPARIMIN DHE ASFALTIM I RRUGËS
 AUTOMOBILIS TIKE FUSHA E ÇAJUPIT – TOPOVË,
 PJESË E UNAZËS SË ZAGORISË L= 8971 ML.

Data:

06/2024

EMERTIMI I FLETES:
 PROFIL TERTHOR

SHK
 1:1000

HARTOI: SEKTORI SHERBIMIT URBAN
 ARK. NELSON SEJDO

Nr. fleta

59

SEKSIONI NR. : 237
 KUOTA PROJEKTIT : 882.391
 PROGRESIVA : 5900.000

SHKALLA 1:100

KUOTA REF. 879.972

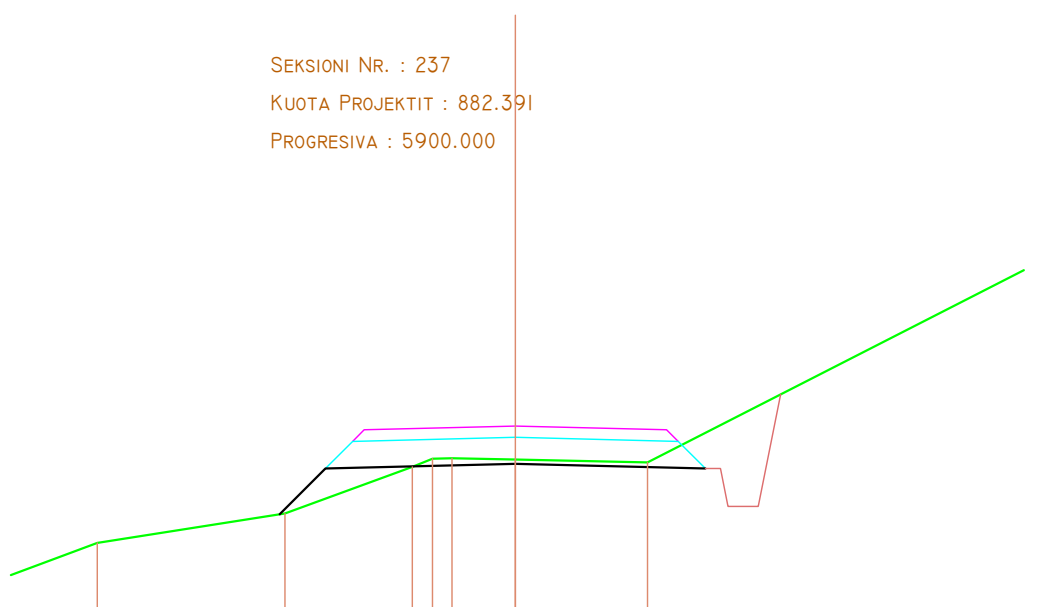

| | | | | | | | | |
|---------------------------|--------|--------|--------|--------|--------|--------|--------|------|
| KUOTA E TOKES | 880.85 | 881.23 | 881.85 | 881.96 | 881.97 | 881.95 | 881.91 | |
| DIST. PJESORE E TOKES | 2.5 | 1.7 | 0.3 | 0.3 | 0.8 | 1.7 | | 10.0 |
| KUOTA E PROJEKTIT | | 881.22 | 881.83 | | | 881.89 | 881.83 | |
| DIST. PJESORE E PROJEKTIT | | 0.6 | 2.5 | | | 2.5 | | |

SEKSIONI NR. : 239
 KUOTA PROJEKTIT : 878.578
 PROGRESIVA : 5950.000

SHKALLA 1:100

KUOTA REF. 874.910

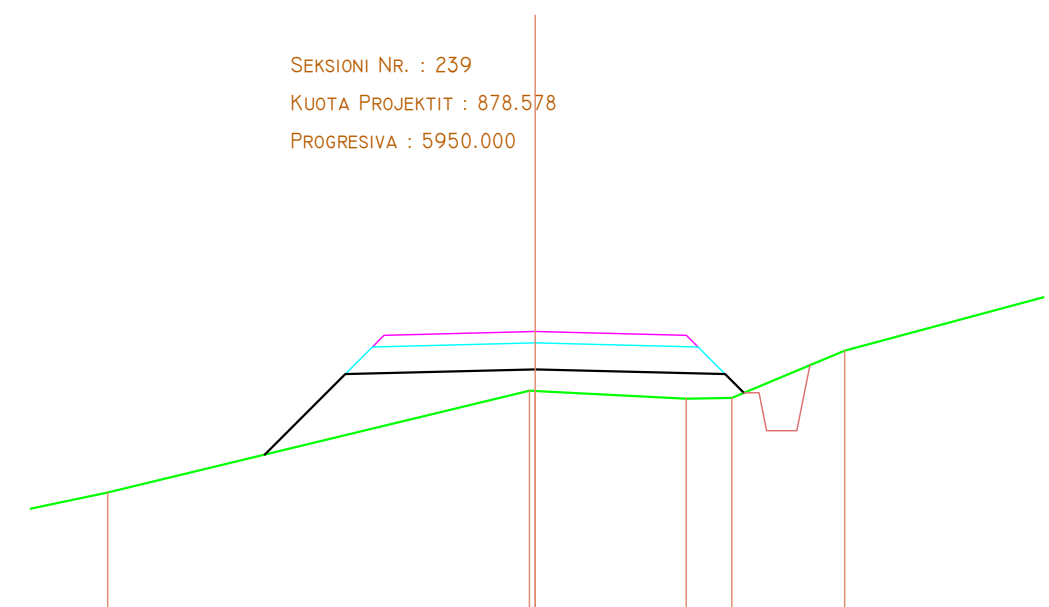

| | | | | | | | | |
|---------------------------|--------|--------|--------|--------|--------|--------|--------|--|
| KUOTA E TOKES | 876.45 | | 877.80 | 877.79 | 877.69 | 877.70 | 878.32 | |
| DIST. PJESORE E TOKES | | 5.6 | 2.0 | 0.6 | 1.5 | | | |
| KUOTA E PROJEKTIT | | 876.95 | 878.01 | 878.08 | | 878.01 | 877.77 | |
| DIST. PJESORE E PROJEKTIT | | 1.1 | 2.5 | 2.5 | | 0.2 | | |

SEKSIONI NR. : 238
 KUOTA PROJEKTIT : 880.504
 PROGRESIVA : 5925.000

SHKALLA 1:100

KUOTA REF. 877.987

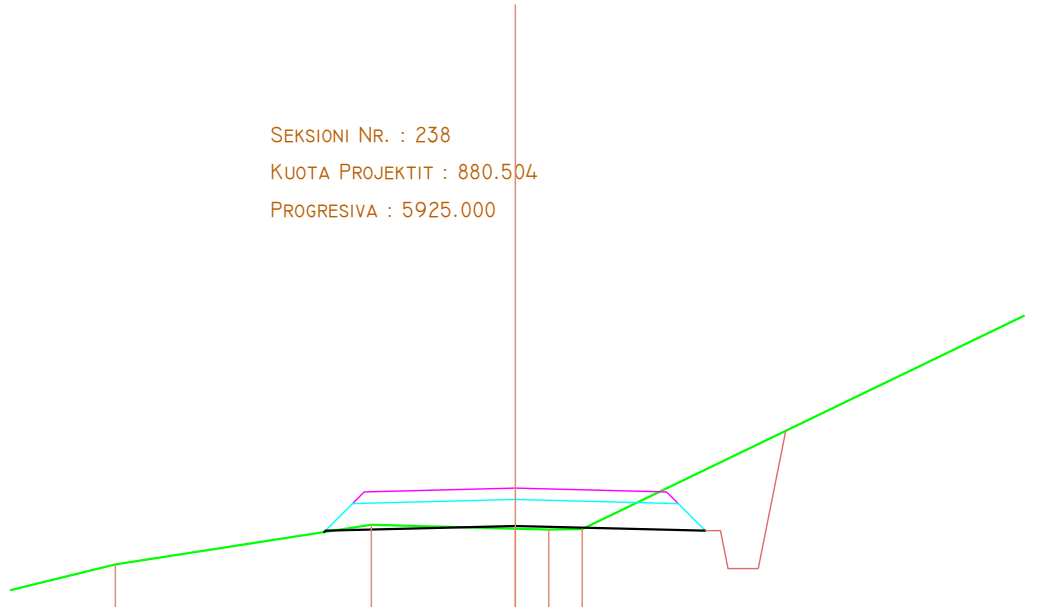

| | | | | | | | | |
|---------------------------|--------|--------|--------|--------|--------|--------|--|--|
| KUOTA E TOKES | 879.50 | 880.02 | 879.97 | 879.96 | 879.96 | | | |
| DIST. PJESORE E TOKES | 3.4 | 1.9 | 0.4 | 0.4 | | 6.0 | | |
| KUOTA E PROJEKTIT | | 879.92 | 879.94 | 880.00 | | 879.94 | | |
| DIST. PJESORE E PROJEKTIT | | 2.5 | | 2.5 | | | | |

SEKSIONI NR. : 240
 KUOTA PROJEKTIT : 876.627
 PROGRESIVA : 5975.000

SHKALLA 1:100

KUOTA REF. 872.940

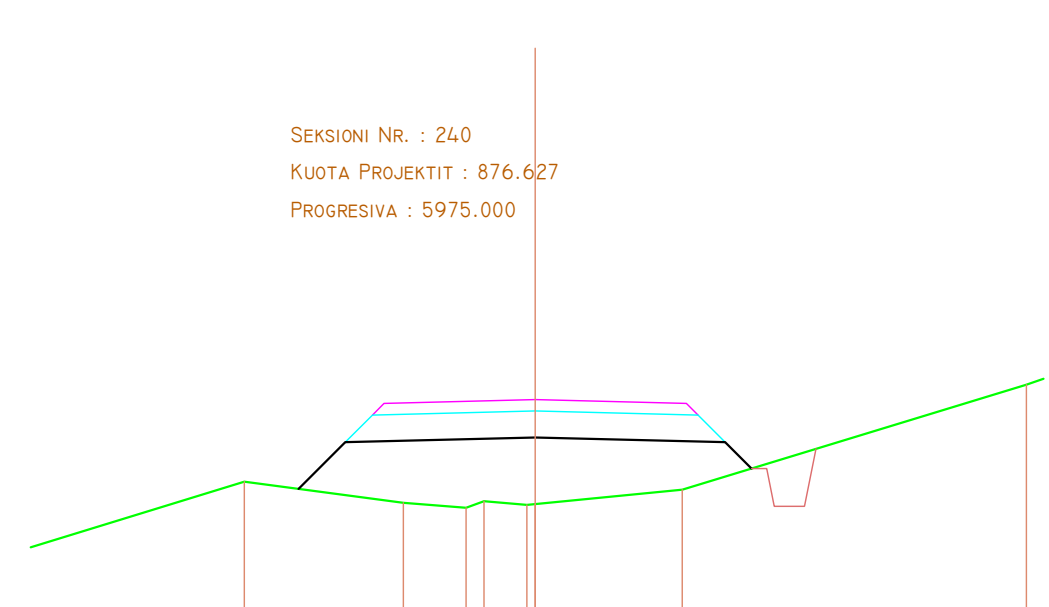

| | | | | | | | | |
|---------------------------|--------|--------|--------|--------|--------|--------|--------|--------|
| KUOTA E TOKES | 875.54 | 875.26 | 875.20 | 875.28 | 875.24 | 875.23 | 875.44 | 876.82 |
| DIST. PJESORE E TOKES | 2.1 | 0.8 | 0.2 | 0.2 | | | | |
| KUOTA E PROJEKTIT | 875.45 | 876.06 | | | | | | |
| DIST. PJESORE E PROJEKTIT | 0.6 | 2.5 | | | | | | |



BASHKIA LIBOHOVE
 OBJEKTI:
 RIPARIMIN DHE ASFALTIM I RRUGËS
 AUTOMOBILIS TIKE FUSHA E ÇAJUPIT – TOPOVË,
 PJESE E UNAZËS SË ZAGORISË L= 8971 ML.

EMERTIMI I FLETES:
 PROFIL TERTHOR

HARTOI: SEKTORI SHERBIMIT URBAN
 ARK. NELSON SEJDO

Data:
 06/2024
 SHK
 1:1000
 Nr. fleta
 60

SEKSIONI NR. : 241
 KUOTA PROJEKTIT : 874.677
 PROGRESIVA : 6000.000

SEKSIONI NR. : 243
 KUOTA PROJEKTIT : 870.172
 PROGRESIVA : 6050.000

SHKALLA 1:100

SHKALLA 1:100

KUOTA REF. 872.211

KUOTA REF. 869.084

| | | | | | | |
|---------------------------|--------|--------|--------|--------|--------|--------|
| KUOTA E TOKES | 873.21 | 873.52 | 874.06 | 874.45 | 874.57 | 874.94 |
| DIST. PJESORE E TOKES | 5.2 | 1.2 | 0.9 | 0.9 | 0.9 | |
| KUOTA E PROJEKTIT | 873.40 | 874.11 | 874.18 | 874.11 | | |
| DIST. PJESORE E PROJEKTIT | 0.7 | 2.5 | 2.5 | | | |

| | | | | | | |
|---------------------------|--------|--------|--------|--------|--------|--------|
| KUOTA E TOKES | 869.90 | 868.99 | 869.78 | 869.96 | 870.15 | 870.68 |
| DIST. PJESORE E TOKES | 4.9 | 1.9 | 0.4 | 0.5 | 0.8 | |
| KUOTA E PROJEKTIT | 869.18 | 869.61 | 869.67 | 869.61 | | |
| DIST. PJESORE E PROJEKTIT | 0.4 | 2.5 | 2.5 | | | |

SEKSIONI NR. : 242
 KUOTA PROJEKTIT : 872.476
 PROGRESIVA : 6025.000

SEKSIONI NR. : 244
 KUOTA PROJEKTIT : 867.869
 PROGRESIVA : 6075.000

SHKALLA 1:100

SHKALLA 1:100

KUOTA REF. 870.759

KUOTA REF. 866.666

| | | | | | | | |
|---------------------------|--------|--------|--------|--------|--------|--------|--------|
| KUOTA E TOKES | 871.79 | 871.77 | 871.80 | 871.91 | 871.96 | 872.18 | 872.64 |
| DIST. PJESORE E TOKES | 0.8 | 0.3 | 1.4 | 1.6 | | | 5.6 |
| KUOTA E PROJEKTIT | 871.72 | 871.91 | 871.98 | 871.91 | | | |
| DIST. PJESORE E PROJEKTIT | 0.2 | 2.5 | 2.5 | | | | |

| | | | | | |
|---------------------------|--------|--------|--------|--------|--------|
| KUOTA E TOKES | 867.23 | 867.12 | 867.09 | 867.15 | 868.65 |
| DIST. PJESORE E TOKES | 2.1 | 0.6 | 0.5 | 2.0 | |
| KUOTA E PROJEKTIT | 867.16 | 867.31 | | | |
| DIST. PJESORE E PROJEKTIT | 2.5 | | | | |



BASHKIA LIBOHOVE

OBJEKTI:
 RIPARIMIN DHE ASFALTIM I RRUGËS
 AUTOMOBILIS TIKE FUSHA E ÇAJUPIT – TOPOVË,
 PJESË E UNAZËS SË ZAGORISË L= 8971 ML.

Data:

06/2024

EMERTIMI I FLETES:

PROFIL TERTHOR

SHK
 1:1000

HARTOI: SEKTORI SHERBIMIT URBAN
 ARK. NELSON SEJDO

Nr. fleta

61

SEKSIONI NR. : 245
 KUOTA PROJEKTIT : 866.298
 PROGRESIVA : 6100.000

SEKSIONI NR. : 247
 KUOTA PROJEKTIT : 863.606
 PROGRESIVA : 6150.000

SHKALLA 1:100

SHKALLA 1:100

KUOTA REF. 865.486

KUOTA REF. 860.695

| | | | | | | | |
|---------------------------|-----|------------------|--------|--------|--------|--------|--------|
| KUOTA E TOKES | | 865.46 | 865.66 | 865.60 | 865.55 | 865.56 | 866.85 |
| DIST. PJESORE E TOKES | 3.9 | 1.7 | 1.6 | 1.1 | 0.4 | 2.0 | |
| KUOTA E PROJEKTIT | | 865.55 865.74 | | 865.80 | | 865.74 | |
| DIST. PJESORE E PROJEKTIT | | 0.2 | 2.5 | 2.5 | | | |

| | | | | | | | |
|---------------------------|--|--------|--------|--------|--------|--------|--------|
| KUOTA E TOKES | | 862.17 | 862.74 | 862.85 | 864.07 | 864.20 | 864.36 |
| DIST. PJESORE E TOKES | | 4.6 | 0.8 | 2.6 | 0.3 | 0.4 | 5.3 |
| KUOTA E PROJEKTIT | | 862.34 | 863.04 | 863.11 | 863.04 | | |
| DIST. PJESORE E PROJEKTIT | | 0.7 | 2.5 | 2.5 | | | |

SEKSIONI NR. : 246
 KUOTA PROJEKTIT : 865.695
 PROGRESIVA : 6125.000

SEKSIONI NR. : 248
 KUOTA PROJEKTIT : 860.897
 PROGRESIVA : 6175.000

SHKALLA 1:100

SHKALLA 1:100

KUOTA REF. 863.423

KUOTA REF. 857.728

| | | | | | | | | |
|---------------------------|-----|------------------|--------|--------|--------|--------|--------|--------|
| KUOTA E TOKES | | 864.27 | 865.23 | 865.38 | 865.40 | 865.43 | 865.47 | 867.53 |
| DIST. PJESORE E TOKES | 4.5 | 0.8 | 0.4 | 1.1 | 1.6 | 3.1 | | |
| KUOTA E PROJEKTIT | | 865.15 865.13 | | 865.20 | | 865.13 | | |
| DIST. PJESORE E PROJEKTIT | | 2.5 | 2.5 | | | | | |

| | | | | | | | |
|---------------------------|--|------------------|--------|--------|--------|--------|--------|
| KUOTA E TOKES | | 860.48 | 860.36 | 860.35 | 860.67 | 860.69 | 861.54 |
| DIST. PJESORE E TOKES | | 1.7 | 2.5 | 0.1 | 2.3 | | |
| KUOTA E PROJEKTIT | | 860.28 860.33 | | 2.5 | | | |
| DIST. PJESORE E PROJEKTIT | | 2.5 | | | | | |



BASHKIA LIBOHOVE

OBJEKTI:
 RIPARIMIN DHE ASFALTIM I RRUGËS
 AUTOMOBILIS TIKE FUSHA E ÇAJUPIT – TOPOVË,
 PJESË E UNAZËS SË ZAGORISË L= 8971 ML.

Data:

06/2024

EMERTIMI I FLETES:
 PROFIL TERTHOR

SHK
 1:1000

HARTOI: SEKTORI SHERBIMIT URBAN
 ARK. NELSON SEJDO

Nr. fleta

62

SEKSIONI NR. : 249
 KUOTA PROJEKTIT : 858.365
 PROGRESIVA : 6200.000

SEKSIONI NR. : 251
 KUOTA PROJEKTIT : 856.887
 PROGRESIVA : 6250.000

SHKALLA 1:100

SHKALLA 1:100

KUOTA REF. 855.285

KUOTA REF. 854.203

| | | | | | | | |
|---------------------------|-----|--------|--------|--------|--------|--------|--------|
| KUOTA E TOKES | | | 857.33 | 857.58 | 857.69 | 857.61 | 858.38 |
| DIST. PJESORE E TOKES | 9.0 | | 1.3 | 0.9 | 1.7 | 1.7 | |
| KUOTA E PROJEKTIT | | 856.65 | 857.80 | 857.87 | 857.80 | 857.67 | |
| DIST. PJESORE E PROJEKTIT | | 1.2 | 2.5 | 2.5 | | | |

| | | | | | | | |
|---------------------------|--|--------|--------|--------|--------|--------|--------|
| KUOTA E TOKES | | 855.60 | 856.27 | 856.32 | 856.51 | 856.62 | 857.45 |
| DIST. PJESORE E TOKES | | 3.7 | 0.3 | 1.6 | 0.7 | 0.8 | |
| KUOTA E PROJEKTIT | | 855.71 | 856.32 | 856.39 | | 856.32 | |
| DIST. PJESORE E PROJEKTIT | | 0.6 | 2.5 | 2.5 | | | |

SEKSIONI NR. : 250
 KUOTA PROJEKTIT : 857.182
 PROGRESIVA : 6225.000

SEKSIONI NR. : 252
 KUOTA PROJEKTIT : 856.597
 PROGRESIVA : 6275.000

SHKALLA 1:100

SHKALLA 1:100

KUOTA REF. 854.232

KUOTA REF. 854.724

| | | | | | | | | |
|---------------------------|--|--------|--------|--------|--------|--------|--------|--------|
| KUOTA E TOKES | | 856.19 | 856.60 | 856.78 | 856.85 | 857.11 | 857.42 | 858.27 |
| DIST. PJESORE E TOKES | | 2.3 | 1.0 | 0.6 | 1.7 | 0.3 | 2.8 | |
| KUOTA E PROJEKTIT | | 855.97 | 856.62 | 856.68 | 856.62 | | | |
| DIST. PJESORE E PROJEKTIT | | 0.7 | 2.5 | 2.5 | | | | |

| | | | | | | | |
|---------------------------|-----|--------|--------|--------|--------|--------|--------|
| KUOTA E TOKES | | 855.73 | 855.88 | 855.81 | 855.83 | 856.07 | 856.84 |
| DIST. PJESORE E TOKES | 7.1 | 0.4 | 0.6 | | | | |
| KUOTA E PROJEKTIT | | 855.45 | 856.03 | | | | |
| DIST. PJESORE E PROJEKTIT | | 0.6 | 2.5 | | | | |



BASHKIA LIBOHOVE
 OBJEKTI:
 RIPARIMIN DHE ASFALTIM I RRUGËS
 AUTOMOBILIS TIKE FUSHA E ÇAJUPIT – TOPOVË,
 PJESË E UNAZËS SË ZAGORISË L= 8971 ML.

Data:
06/2024

EMERTIMI I FLETES:
 PROFIL TERTHOR

SHK
1:1000

HARTOI: SEKTORI SHERBIMIT URBAN
 ARK. NELSON SEJDO

Nr. fleta
63

SEKSIONI NR. : 253
 KUOTA PROJEKTIT : 856.546
 PROGRESIVA : 6300.000

SEKSIONI NR. : 255
 KUOTA PROJEKTIT : 857.271
 PROGRESIVA : 6350.000

SHKALLA 1:100

SHKALLA 1:100

KUOTA REF. 855.194

KUOTA REF. 857.508

| | | | | | | |
|---------------------------|-----|--------|--------|--------|--------|-----|
| KUOTA E TOKES | | 855.95 | 855.95 | 855.95 | 856.16 | |
| DIST. PJESORE E TOKES | 6.3 | 0.6 | 0.7 | 1.5 | | 7.3 |
| KUOTA E PROJEKTIT | | 855.52 | 855.98 | 856.05 | 855.98 | |
| DIST. PJESORE E PROJEKTIT | | 0.5 | 2.5 | 2.5 | | |

| | | | | | | | |
|---------------------------|--|--------|--------|--------|--------|--------|--------|
| KUOTA E TOKES | | 856.37 | 856.39 | 856.80 | 856.96 | 857.20 | 859.25 |
| DIST. PJESORE E TOKES | | 1.5 | 1.1 | 0.4 | 0.7 | 3.8 | 3.1 |
| KUOTA E PROJEKTIT | | 856.40 | 856.71 | 856.77 | | 856.71 | |
| DIST. PJESORE E PROJEKTIT | | 0.3 | 2.5 | 2.5 | | | |

SEKSIONI NR. : 254
 KUOTA PROJEKTIT : 856.908
 PROGRESIVA : 6325.000

SEKSIONI NR. : 256
 KUOTA PROJEKTIT : 858.082
 PROGRESIVA : 6375.000

SHKALLA 1:100

SHKALLA 1:100

KUOTA REF. 856.560

KUOTA REF. 857.652

| | | | | | | |
|---------------------------|-----|--------|--------|--------|--------|--|
| KUOTA E TOKES | | 856.36 | 856.37 | 856.37 | 856.37 | |
| DIST. PJESORE E TOKES | 7.1 | 0.8 | 0.3 | 1.1 | | |
| KUOTA E PROJEKTIT | | 856.17 | 856.35 | 856.41 | 856.35 | |
| DIST. PJESORE E PROJEKTIT | | 0.2 | 2.5 | 2.5 | | |

| | | | | | | | |
|---------------------------|--|--------|--------|--------|--------|--------|--------|
| KUOTA E TOKES | | 857.50 | 857.40 | 857.41 | 857.52 | 857.57 | 857.61 |
| DIST. PJESORE E TOKES | | 2.4 | 1.5 | | | | |
| KUOTA E PROJEKTIT | | 857.44 | 857.52 | | | | |
| DIST. PJESORE E PROJEKTIT | | | 2.5 | | | | |

| | |
|---|------------------|
| BASHKIA LIBOHOVE | |
|  OBJEKTI: RIPARIMIN DHE ASFALTIM I RRUGËS AUTOMOBILIS TIKE FUSHA E ÇAJUPIT – TOPOVË, PJESË E UNAZËS SË ZAGORISË L= 8971 ML. | Data: 06/2024 |
| EMERTIMI I FLETES: PROFIL TERTHOR | SHK 1:1000 |
| HARTOI: SEKTORI SHERBIMIT URBAN ARK. NELSON SEJDO | Nr. fleta 64 |

SEKSIONI NR. : 257
 KUOTA PROJEKTIT : 859.545
 PROGRESIVA : 6400.000

SEKSIONI NR. : 259
 KUOTA PROJEKTIT : 860.066
 PROGRESIVA : 6450.000

SHKALLA 1:100

SHKALLA 1:100

KUOTA REF. 858.395

KUOTA REF. 857.498

| | | | | | |
|---------------------------|--------|------------------|------------------|--------|------|
| KUOTA E TOKES | 858.47 | 858.99 | 858.93 858.92 | 859.05 | |
| DIST. PJESORE E TOKES | 4.8 | 1.5 | 0.7 | | 11.1 |
| KUOTA E PROJEKTIT | | 858.87 858.98 | 859.05 | 858.98 | |
| DIST. PJESORE E PROJEKTIT | | 2.5 | 2.5 | | |

| | | | | | | | |
|---------------------------|-----|--------|--------|--------|--------|--------|--------|
| KUOTA E TOKES | | 859.29 | 859.18 | 859.15 | 859.13 | 859.72 | 860.29 |
| DIST. PJESORE E TOKES | 8.2 | 0.6 | 0.4 | 0.2 | | 3.1 | 1.8 |
| KUOTA E PROJEKTIT | | 858.82 | 859.50 | 859.57 | | 859.50 | |
| DIST. PJESORE E PROJEKTIT | | 0.7 | 2.5 | 2.5 | | | |

SEKSIONI NR. : 258
 KUOTA PROJEKTIT : 860.029
 PROGRESIVA : 6425.000

SEKSIONI NR. : 260
 KUOTA PROJEKTIT : 860.103
 PROGRESIVA : 6475.000

SHKALLA 1:100

SHKALLA 1:100

KUOTA REF. 858.780

KUOTA REF. 859.051

| | | | | | | |
|---------------------------|--|--------|--------|------------------|--------|--------|
| KUOTA E TOKES | | 860.11 | 859.82 | 859.73 859.74 | 859.86 | 860.44 |
| DIST. PJESORE E TOKES | | 1.7 | 1.2 | 0.7 | 1.7 | 3.4 |
| KUOTA E PROJEKTIT | | 860.10 | 859.47 | 859.53 | 859.47 | |
| DIST. PJESORE E PROJEKTIT | | 0.6 | 2.5 | 2.5 | | |

| | | | | | |
|---------------------------|--|------------------|------------------|--------|--------|
| KUOTA E TOKES | | 859.59 | 859.61 859.61 | 859.79 | 859.77 |
| DIST. PJESORE E TOKES | | 0.8 | | | |
| KUOTA E PROJEKTIT | | 859.47 859.54 | | | |
| DIST. PJESORE E PROJEKTIT | | 2.5 | | | |

BASHKIA LIBOHOVE

OBJEKTI:
 RIPARIMIN DHE ASFALTIM I RRUGËS
 AUTOMOBILIS TIKE FUSHA E ÇAJUPIT – TOPOVË,
 PJESË E UNAZËS SË ZAGORISË L= 8971 ML.

EMERTIMI I FLETES:
 PROFIL TERTHOR

HARTOI: SEKTORI SHERBIMIT URBAN
 ARK. NELSON SEJDO

Data: 06/2024
 SHK 1:1000
 Nr. fleta 65

SEKSIONI NR. : 261
 KUOTA PROJEKTIT : 860.140
 PROGRESIVA : 6500.000

SHKALLA 1:100

KUOTA REF. 858.531

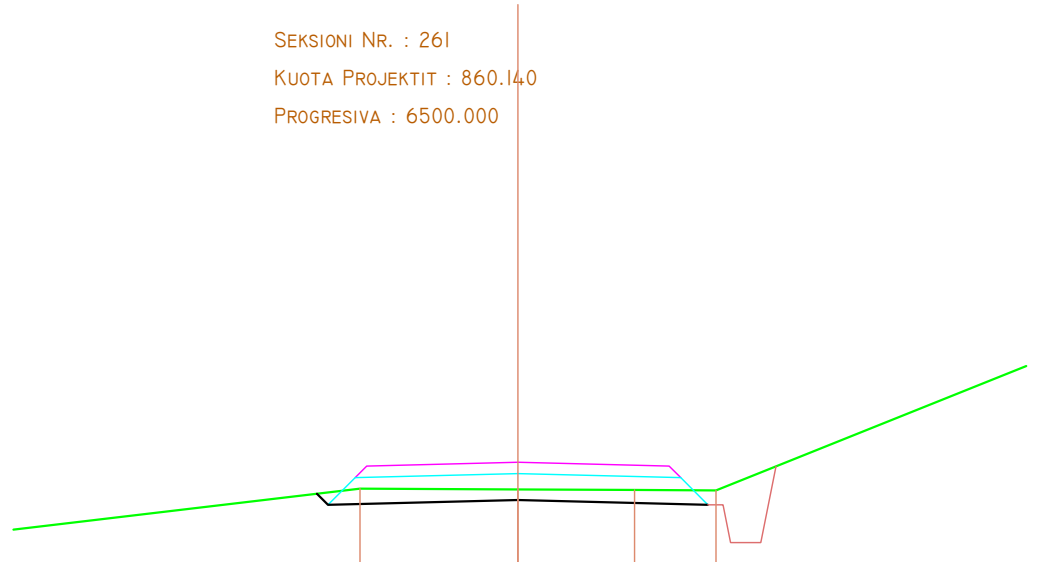

| | | | | | |
|---------------------------|--|------------------|--------|--------|--------|
| KUOTA E TOKES | | 859.79 | 859.78 | 859.77 | 859.77 |
| DIST. PJESORE E TOKES | | 2.1 | 1.5 | 1.1 | |
| KUOTA E PROJEKTIT | | 859.72 859.58 | 859.64 | 859.58 | |
| DIST. PJESORE E PROJEKTIT | | 2.5 | 2.5 | | |

SEKSIONI NR. : 263
 KUOTA PROJEKTIT : 860.486
 PROGRESIVA : 6550.000

SHKALLA 1:100

KUOTA REF. 855.808

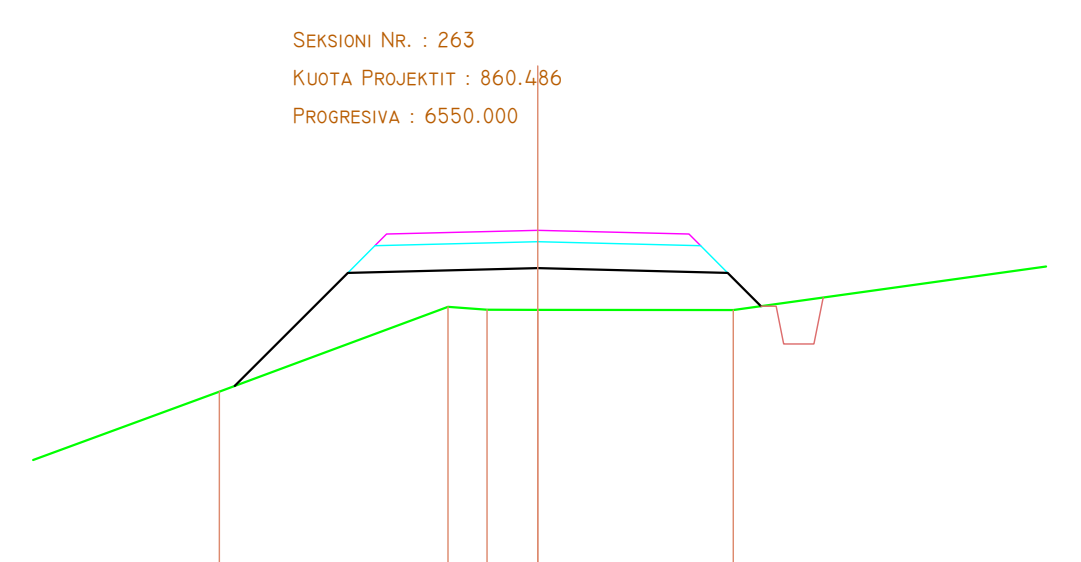

| | | | | | | |
|---------------------------|--|--------|--------|--------|--------|--------|
| KUOTA E TOKES | | 858.35 | 859.47 | 859.43 | 859.43 | 859.43 |
| DIST. PJESORE E TOKES | | 2.6 | 3.0 | 0.5 | 0.7 | 2.6 |
| KUOTA E PROJEKTIT | | 858.43 | 859.92 | 859.99 | 859.92 | 859.48 |
| DIST. PJESORE E PROJEKTIT | | 1.5 | 2.5 | 2.5 | 0.4 | |

SEKSIONI NR. : 262
 KUOTA PROJEKTIT : 860.177
 PROGRESIVA : 6525.000

SHKALLA 1:100

KUOTA REF. 857.788

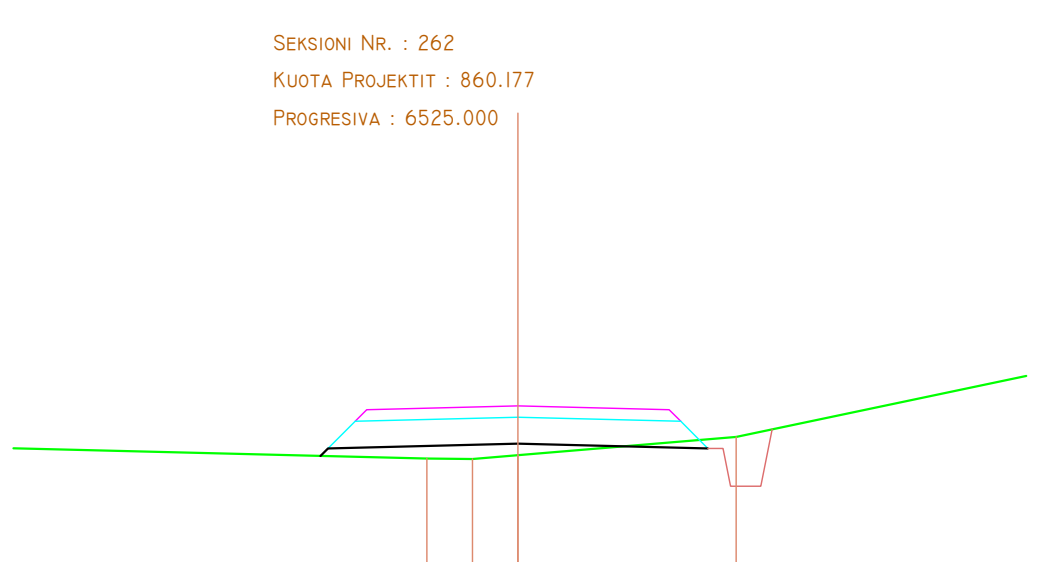

| | | | | | |
|---------------------------|-----|------------------|--------|--------|--------|
| KUOTA E TOKES | | 859.48 | 859.47 | 859.52 | 859.77 |
| DIST. PJESORE E TOKES | 8.9 | 0.6 | 0.6 | 2.9 | |
| KUOTA E PROJEKTIT | | 859.52 859.61 | 859.68 | 859.61 | |
| DIST. PJESORE E PROJEKTIT | | 2.5 | 2.5 | | |

SEKSIONI NR. : 264
 KUOTA PROJEKTIT : 861.484
 PROGRESIVA : 6575.000

SHKALLA 1:100

KUOTA REF. 858.967

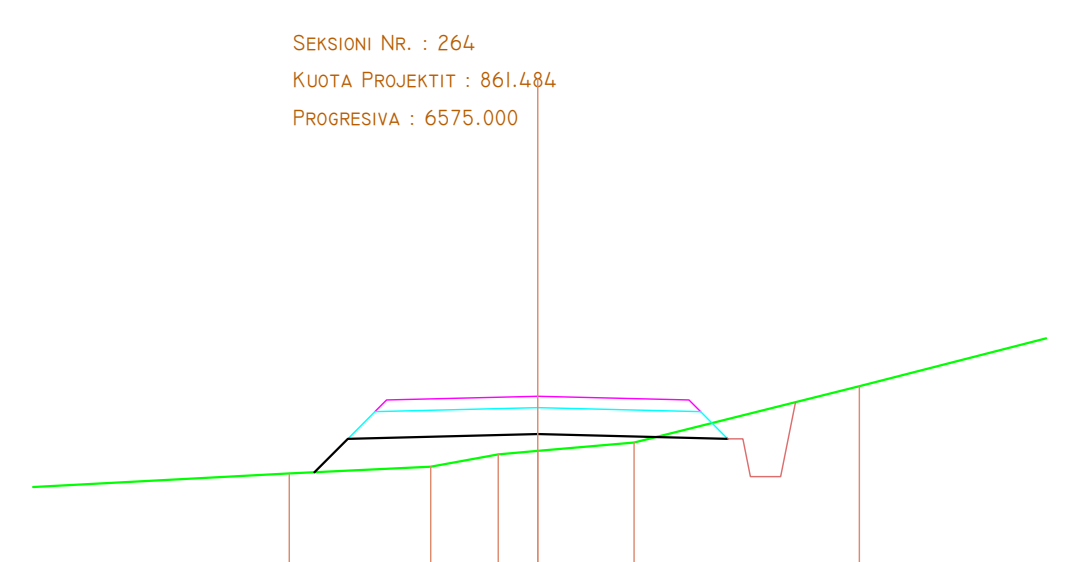

| | | | | | | | |
|---------------------------|--|------------------|--------|--------|--------|--------|--------|
| KUOTA E TOKES | | 860.46 | 860.55 | 860.71 | 860.76 | 860.87 | 861.62 |
| DIST. PJESORE E TOKES | | 1.9 | 0.9 | 0.5 | 1.3 | 3.0 | |
| KUOTA E PROJEKTIT | | 860.46 860.92 | | | | | |
| DIST. PJESORE E PROJEKTIT | | 0.4 | 2.5 | | | | |

BASHKIA LIBOHOVE

OBJEKTI:
 RIPARIMIN DHE ASFALTIM I RRUGËS
 AUTOMOBILIS TIKE FUSHA E ÇAJUPIT – TOPOVË,
 PJESË E UNAZËS SË ZAGORISË L= 8971 ML.

EMERTIMI I FLETES:
 PROFIL TERTHOR

HARTOI: SEKTORI SHERBIMIT URBAN
 ARK. NELSON SEJDO

Data:
 06/2024

SHK
 1:1000

Nr. fleta
 66

SEKSIONI NR. : 265
 KUOTA PROJEKTIT : 863.092
 PROGRESIVA : 6600.000

SHKALLA 1:100

KUOTA REF. 861.198

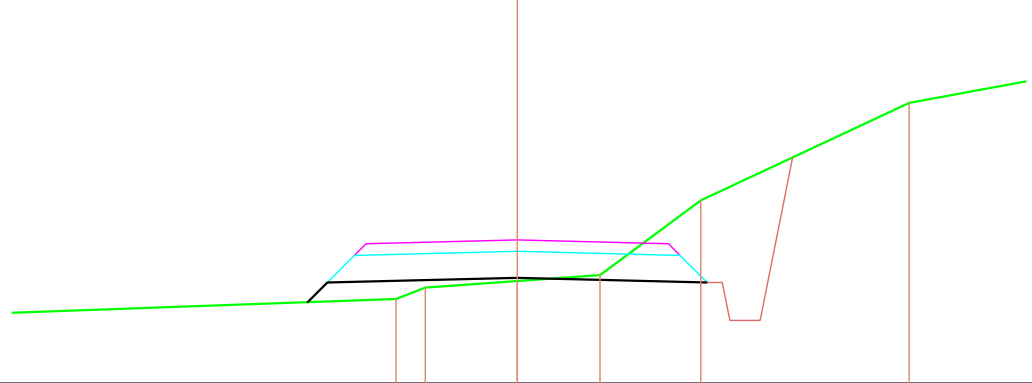

| | | | | | | | |
|---------------------------|-----|------------------|--------|--------|--------|--------|--------|
| KUOTA E TOKES | | 862.31 | 862.46 | 862.55 | 862.63 | 863.62 | 864.91 |
| DIST. PJESORE E TOKES | 5.2 | 0.4 | 1.2 | 1.1 | 1.3 | 2.8 | |
| KUOTA E PROJEKTIT | | 862.27 862.53 | | 862.59 | | 862.53 | |
| DIST. PJESORE E PROJEKTIT | | 0.3 | 2.5 | | 2.5 | | |

SEKSIONI NR. : 267
 KUOTA PROJEKTIT : 866.487
 PROGRESIVA : 6650.000

SHKALLA 1:100

KUOTA REF. 862.754

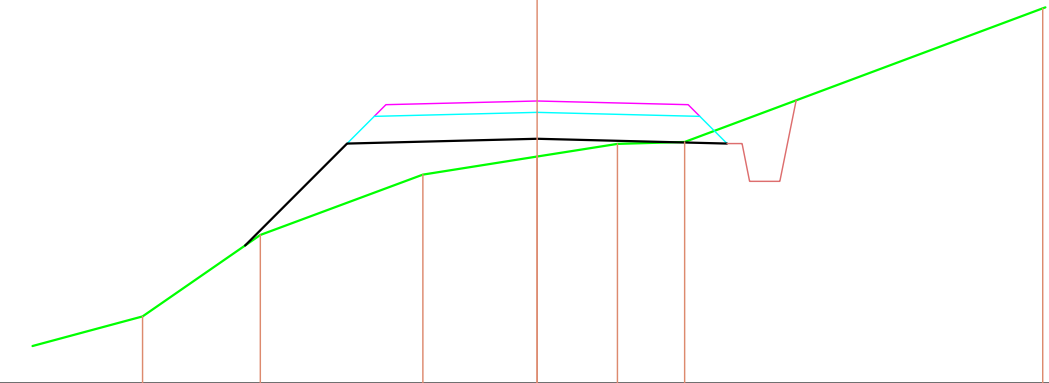

| | | | | | | | |
|---------------------------|--|--------|--------|--------|--------|--------|--------|
| KUOTA E TOKES | | 863.64 | 864.71 | 865.51 | 865.75 | 865.92 | 865.94 |
| DIST. PJESORE E TOKES | | 1.6 | 2.1 | 1.5 | 1.1 | 0.9 | 4.7 |
| KUOTA E PROJEKTIT | | | 864.57 | 865.92 | | 865.99 | 865.92 |
| DIST. PJESORE E PROJEKTIT | | | 1.3 | 2.5 | | 2.5 | |

SEKSIONI NR. : 266
 KUOTA PROJEKTIT : 864.789
 PROGRESIVA : 6625.000

SHKALLA 1:100

KUOTA REF. 863.172

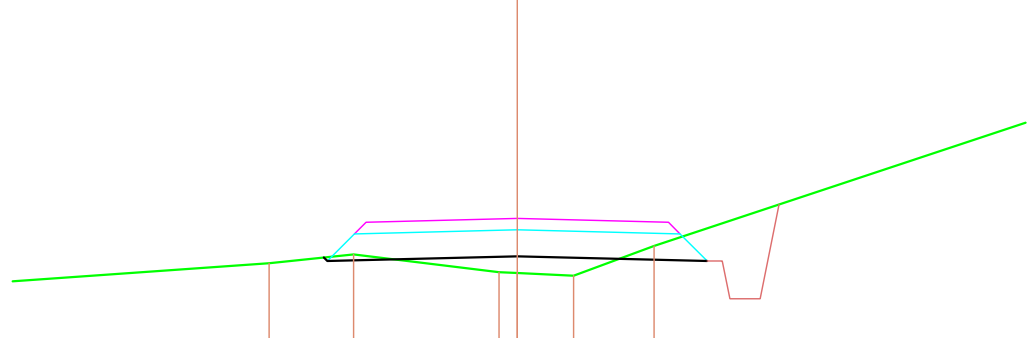

| | | | | | | |
|---------------------------|-----|------------------|--------|------------------|--------|--------|
| KUOTA E TOKES | | 864.20 | 864.31 | 864.08 864.07 | 864.03 | 864.43 |
| DIST. PJESORE E TOKES | 3.7 | 1.1 | 1.9 | 0.2 0.7 | 1.1 | |
| KUOTA E PROJEKTIT | | 864.27 864.23 | | 864.29 | | 864.23 |
| DIST. PJESORE E PROJEKTIT | | | 2.5 | | 2.5 | |

SEKSIONI NR. : 268
 KUOTA PROJEKTIT : 868.008
 PROGRESIVA : 6675.000

SHKALLA 1:100

KUOTA REF. 866.387

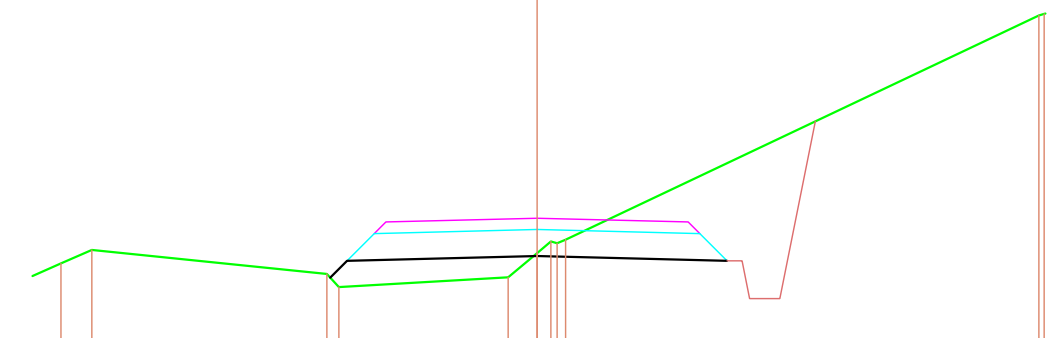

| | | | | | | | |
|---------------------------|--|--------|--------|--------|------------------|--|-----|
| KUOTA E TOKES | | 867.20 | 867.41 | 867.59 | 867.27 867.10 | 867.23 867.55 867.70 867.68 867.92 | |
| DIST. PJESORE E TOKES | | 0.4 | 3.1 | | 2.2 | 0.4 0.2 | 6.3 |
| KUOTA E PROJEKTIT | | | | | 867.22 867.44 | | |
| DIST. PJESORE E PROJEKTIT | | | | | 0.2 | | 2.5 |



BASHKIA LIBOHOVE
 OBJEKTI:
 RIPARIMIN DHE ASFALTIM I RRUGËS
 AUTOMOBILIS TIKE FUSHA E ÇAJUPIT – TOPOVË,
 PJESË E UNAZËS SË ZAGORISË L= 8971 ML.

EMERTIMI I FLETES:
 PROFIL TERTHOR

HARTOI: SEKTORI SHERBIMIT URBAN
 ARK. NELSON SEJDO

Data:
 06/2024
 SHK
 1:1000
 Nr. fleta
 67

SEKSIONI NR. : 269
 KUOTA PROJEKTIT : 867.812
 PROGRESIVA : 6700.000

SEKSIONI NR. : 271
 KUOTA PROJEKTIT : 865.597
 PROGRESIVA : 6750.000

SHKALLA 1:100

SHKALLA 1:100

KUOTA REF. 866.028

KUOTA REF. 863.005

| | | | | | | | | | |
|---------------------------|--|--------|--------|--------|--------|--------|--------|--------|--------|
| KUOTA E TOKES | | 868.06 | 867.72 | 867.75 | 867.77 | 867.18 | 866.95 | 866.62 | 866.95 |
| DIST. PJESORE E TOKES | | 0.3 | 0.2 | 2.1 | | 0.8 | | 4.0 | 0.7 |
| KUOTA E PROJEKTIT | | 867.96 | 867.25 | | | 867.31 | | 867.25 | |
| DIST. PJESORE E PROJEKTIT | | 0.7 | 2.5 | | | 2.5 | | | |

| | | | | | | | |
|---------------------------|--|--------|--------|--------|--------|--------|--------|
| KUOTA E TOKES | | 864.88 | 864.98 | 864.98 | 865.00 | 865.10 | 865.71 |
| DIST. PJESORE E TOKES | | 7.6 | 2.1 | 0.4 | 2.9 | 2.6 | |
| KUOTA E PROJEKTIT | | 864.86 | 865.03 | 865.10 | | 865.03 | |
| DIST. PJESORE E PROJEKTIT | | 0.2 | 2.5 | 2.5 | | | |

SEKSIONI NR. : 270
 KUOTA PROJEKTIT : 866.723
 PROGRESIVA : 6725.000

SEKSIONI NR. : 272
 KUOTA PROJEKTIT : 862.530
 PROGRESIVA : 6775.000

SHKALLA 1:100

SHKALLA 1:100

KUOTA REF. 863.632

KUOTA REF. 859.075

| | | | | | | | | |
|---------------------------|--|--------|--------|--------|--------|--------|--------|--------|
| KUOTA E TOKES | | 865.65 | 865.67 | 866.17 | 866.29 | 866.38 | 866.38 | 866.92 |
| DIST. PJESORE E TOKES | | 0.2 | 4.9 | 1.7 | 1.3 | 0.7 | 2.0 | |
| KUOTA E PROJEKTIT | | 866.08 | 866.16 | | 866.22 | | 866.16 | |
| DIST. PJESORE E PROJEKTIT | | | 2.5 | | 2.5 | | | |

| | | | | | | |
|---------------------------|--|--------|--------|--------|--------|--------|
| KUOTA E TOKES | | 861.94 | 861.87 | 861.98 | 861.70 | 861.01 |
| DIST. PJESORE E TOKES | | 7.5 | 1.5 | 0 | | |
| KUOTA E PROJEKTIT | | 862.04 | 861.97 | | | |
| DIST. PJESORE E PROJEKTIT | | 2.5 | | | | |



BASHKIA LIBOHOVE

OBJEKTI:
 RIPARIMIN DHE ASFALTIM I RRUGËS
 AUTOMOBILIS TIKE FUSHA E ÇAJUPIT – TOPOVË,
 PJESË E UNAZËS SË ZAGORISË L= 8971 ML.

Data:
 06/2024

EMERTIMI I FLETES:
 PROFIL TERTHOR

SHK
 1:1000

HARTOI: SEKTORI SHERBIMIT URBAN
 ARK. NELSON SEJDO

Nr. fleta
 68

SEKSIONI NR. : 273
 KUOTA PROJEKTIT : 859.176
 PROGRESIVA : 6800.000

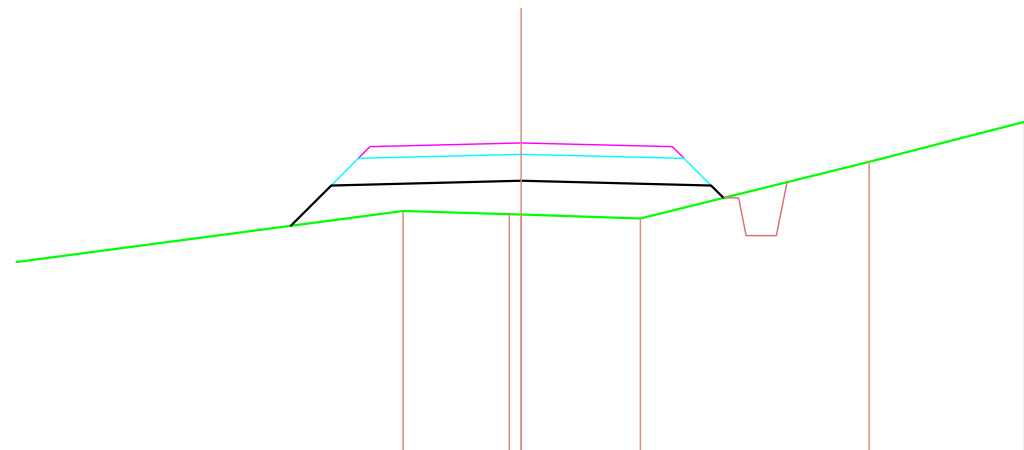

SHKALLA 1:100

KUOTA REF. 855.085

| | | | | | | |
|---------------------------|-----|------------------|------------------|------------------|--------|--|
| KUOTA E TOKES | | 858.28 | 858.23 858.23 | 858.18 | 858.93 | |
| DIST. PJESORE E TOKES | 7.6 | 1.4 | 1.6 | 3.0 | 2.1 | |
| KUOTA E PROJEKTIT | | 858.08 858.61 | 858.68 | 858.61 858.45 | | |
| DIST. PJESORE E PROJEKTIT | | 0.5 | 2.5 | 2.5 | 0.7 | |

SEKSIONI NR. : 275
 KUOTA PROJEKTIT : 855.656
 PROGRESIVA : 6850.000

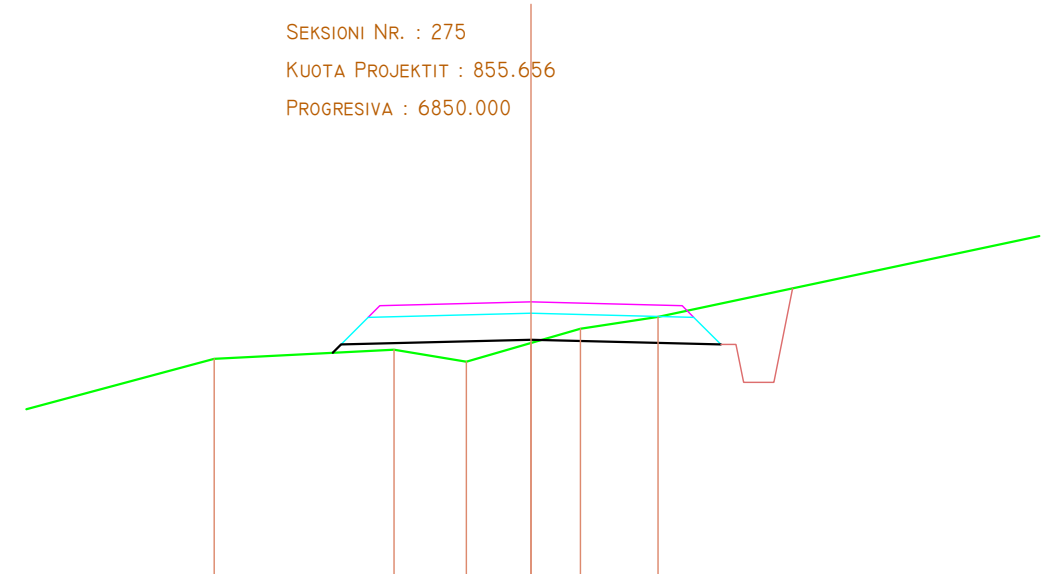

SHKALLA 1:100

KUOTA REF. 852.028

| | | | | | | | |
|---------------------------|--|------------------|--------|--------|--------|--------|--------|
| KUOTA E TOKES | | 854.90 | 855.02 | 854.87 | 855.11 | 855.30 | 855.46 |
| DIST. PJESORE E TOKES | | 2.4 | 1.0 | 0.9 | 0.7 | 1.0 | 7.1 |
| KUOTA E PROJEKTIT | | 854.98 855.09 | | | 855.16 | | 855.09 |
| DIST. PJESORE E PROJEKTIT | | | 2.5 | | | 2.5 | |

SEKSIONI NR. : 274
 KUOTA PROJEKTIT : 857.200
 PROGRESIVA : 6825.000

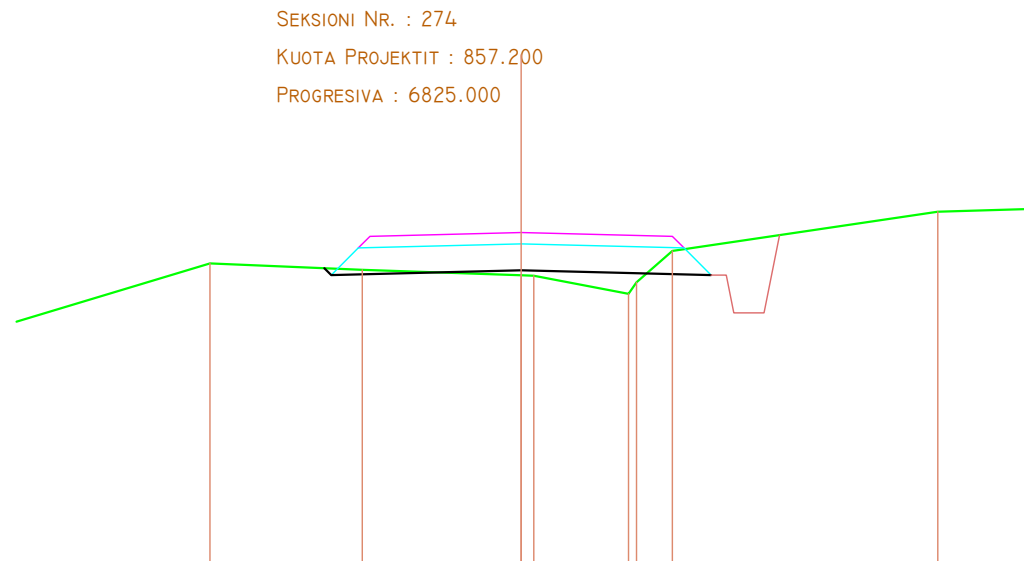

SHKALLA 1:100

KUOTA REF. 852.832

| | | | | | | | |
|---------------------------|--|------------------|--------|------------------|------------------|--------|--------|
| KUOTA E TOKES | | 856.79 | 856.71 | 856.63 856.63 | 856.39 856.34 | 856.96 | 857.47 |
| DIST. PJESORE E TOKES | | 2.0 | 2.1 | 0.2 | 1.3 | 0.5 | 3.5 |
| KUOTA E PROJEKTIT | | 856.73 856.64 | | 856.70 | | 856.64 | |
| DIST. PJESORE E PROJEKTIT | | | 2.5 | | 2.5 | | |

SEKSIONI NR. : 276
 KUOTA PROJEKTIT : 854.211
 PROGRESIVA : 6875.000

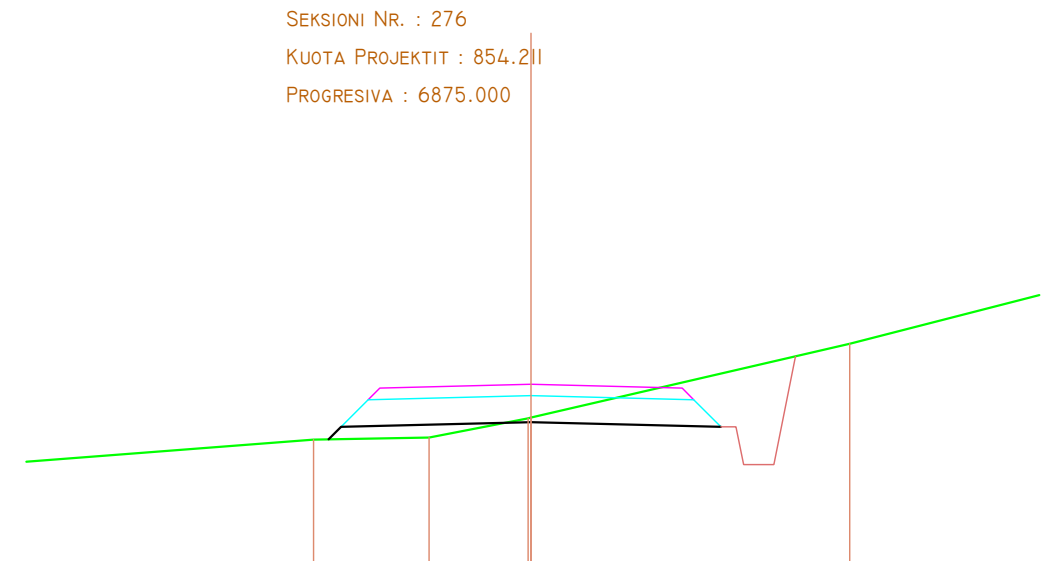

SHKALLA 1:100

KUOTA REF. 851.850

| | | | | | |
|---------------------------|--|------------------|--------|------------------|--------|
| KUOTA E TOKES | | 853.48 | 853.51 | 853.76 853.77 | 854.75 |
| DIST. PJESORE E TOKES | | 4.6 | 1.5 | 1.3 | |
| KUOTA E PROJEKTIT | | 853.48 853.65 | | | |
| DIST. PJESORE E PROJEKTIT | | | 2.5 | | |



BASHKIA LIBOHOVE

OBJEKTI:
 RIPARIMIN DHE ASFALTIM I RRUGËS
 AUTOMOBILIS TIKE FUSHA E ÇAJUPIT – TOPOVË,
 PJESE E UNAZËS SË ZAGORISË L= 8971 ML.

Data:
 06/2024

EMERTIMI I FLETES:
 PROFIL TERTHOR

SHK
 1:1000

HARTOI: SEKTORI SHERBIMIT URBAN
 ARK. NELSON SEJDO

Nr. fleta
 69

SEKSIONI NR. : 277
 KUOTA PROJEKTIT : 853.573
 PROGRESIVA : 6900.000

SHKALLA 1:100

KUOTA REF. 850.865

| | | | | | | | |
|---------------------------|--|------------------|--------|--------|--------|--------|--------|
| KUOTA E TOKES | | 852.79 | 852.92 | 852.92 | 852.92 | 853.03 | 853.74 |
| DIST. PJESORE E TOKES | | | 1.1 | 1.0 | 0.8 | 1.5 | 2.0 |
| KUOTA E PROJEKTIT | | 852.69 853.01 | | 853.07 | | 853.01 | |
| DIST. PJESORE E PROJEKTIT | | 0.3 | 2.5 | | 2.5 | | |

SEKSIONI NR. : 279
 KUOTA PROJEKTIT : 851.630
 PROGRESIVA : 6950.000

SHKALLA 1:100

KUOTA REF. 847.195

| | | | | | | | | |
|---------------------------|--|--------|--------|--------|--------|--------|--------|------------------|
| KUOTA E TOKES | | 849.91 | 850.69 | 850.79 | 850.99 | 851.16 | 851.20 | 850.99 |
| DIST. PJESORE E TOKES | | 2.3 | 1.6 | 0.4 | 0.3 | 0.5 | 0.6 | 8.2 |
| KUOTA E PROJEKTIT | | 850.24 | 851.07 | | 851.13 | | | 851.07 850.94 |
| DIST. PJESORE E PROJEKTIT | | 0.8 | 2.5 | | 2.5 | | | |

SEKSIONI NR. : 278
 KUOTA PROJEKTIT : 852.949
 PROGRESIVA : 6925.000

SHKALLA 1:100

KUOTA REF. 850.152

| | | | | | | | | |
|---------------------------|--|------------------|--------|--------|--------|--------|--------|--------|
| KUOTA E TOKES | | 852.75 | 852.78 | 852.70 | 852.65 | 852.65 | 852.66 | 852.70 |
| DIST. PJESORE E TOKES | | 0.7 | 1.4 | 0.7 | 0.4 | 0.8 | | 2.3 |
| KUOTA E PROJEKTIT | | 852.75 852.39 | | 852.45 | | | | 852.39 |
| DIST. PJESORE E PROJEKTIT | | 0.4 | 2.5 | | 2.5 | | | |

SEKSIONI NR. : 280
 KUOTA PROJEKTIT : 850.139
 PROGRESIVA : 6975.000

SHKALLA 1:100

KUOTA REF. 846.807

| | | | | | | |
|---------------------------|--|------------------|--------|--------|--------|--------|
| KUOTA E TOKES | | 849.44 | 849.66 | 849.68 | 849.69 | 849.92 |
| DIST. PJESORE E TOKES | | 5.0 | 2.3 | | | |
| KUOTA E PROJEKTIT | | 849.43 849.18 | | | | |
| DIST. PJESORE E PROJEKTIT | | 2.5 | | | | |



BASHKIA LIBOHOVE

OBJEKTI:
 RIPARIMIN DHE ASFALTIM I RRUGËS
 AUTOMOBILIS TIKE FUSHA E ÇAJUPIT – TOPOVË,
 PJESË E UNAZËS SË ZAGORISË L= 8971 ML.

Data:
 06/2024

EMERTIMI I FLETES:
 PROFIL TERTHOR

SHK
 1:1000

HARTOI: SEKTORI SHERBIMIT URBAN
 ARK. NELSON SEJDO

Nr. fleta
 70

SEKSIONI NR. : 281
 KUOTA PROJEKTIT : 848.723
 PROGRESIVA : 7000.000

SHKALLA 1:100

KUOTA REF. 845.100

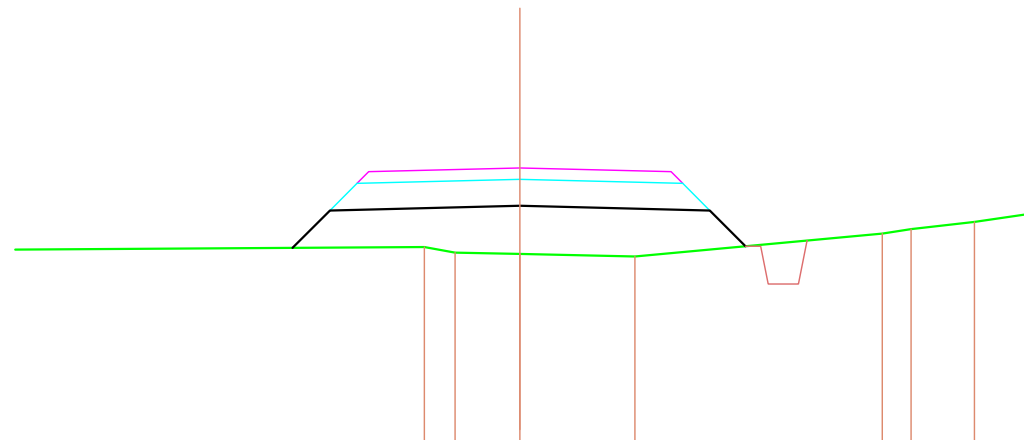

| | | | | | | | | | |
|---------------------------|-----|--------|--------|--------|--------|--------|--------|--------|--------|
| KUOTA E TOKES | | 847.68 | 847.60 | 847.59 | 847.55 | | 847.85 | 847.92 | 848.01 |
| DIST. PJESORE E TOKES | 6.8 | 0.4 | 0.9 | 1.5 | 3.3 | | 0.4 | 0.8 | |
| KUOTA E PROJEKTIT | | 847.67 | 848.16 | 848.22 | | 848.16 | 847.69 | | |
| DIST. PJESORE E PROJEKTIT | | 0.5 | 2.5 | 2.5 | 0.5 | | | | |

SEKSIONI NR. : 283
 KUOTA PROJEKTIT : 847.080
 PROGRESIVA : 7050.000

SHKALLA 1:100

KUOTA REF. 844.711

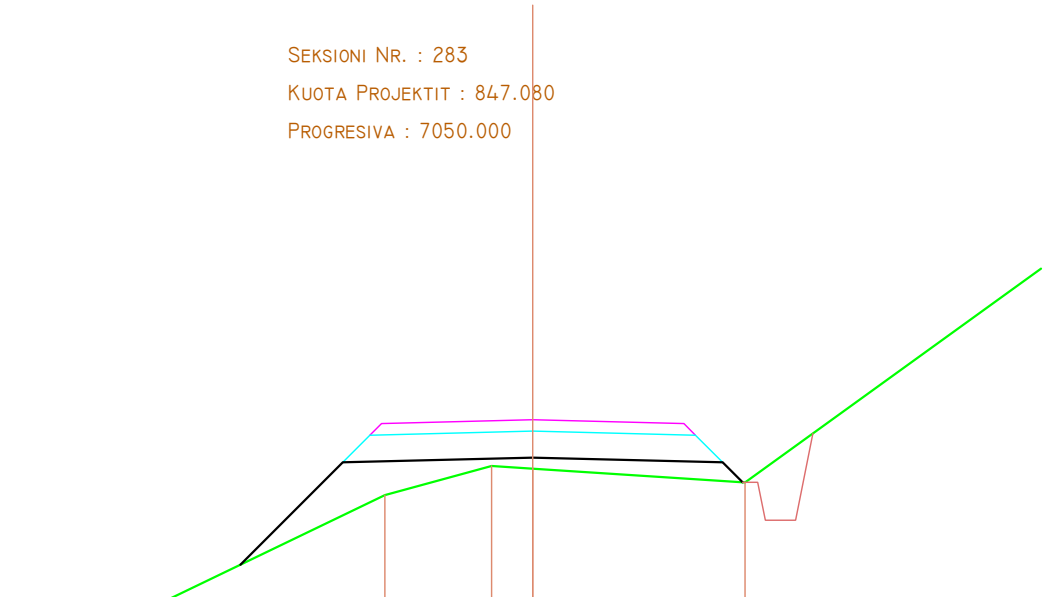

| | | | | | |
|---------------------------|--|--------|--------|--------|--------|
| KUOTA E TOKES | | 846.08 | 846.47 | 846.43 | 846.25 |
| DIST. PJESORE E TOKES | | 1.4 | 0.5 | 2.8 | |
| KUOTA E PROJEKTIT | | 845.16 | 846.52 | 846.58 | 846.52 |
| DIST. PJESORE E PROJEKTIT | | 1.4 | 2.5 | 2.5 | 0.3 |

SEKSIONI NR. : 282
 KUOTA PROJEKTIT : 847.693
 PROGRESIVA : 7025.000

SHKALLA 1:100

KUOTA REF. 845.857

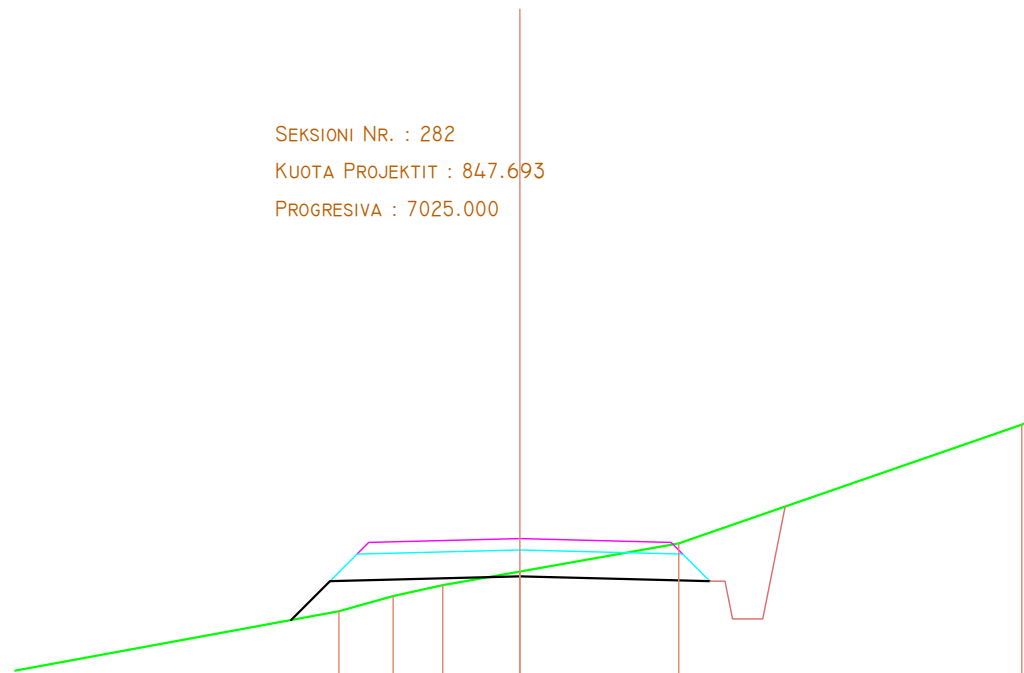

| | | | | | | |
|---------------------------|--|--------|--------|--------|--------|--------|
| KUOTA E TOKES | | 846.73 | 846.93 | 847.08 | 847.26 | 847.63 |
| DIST. PJESORE E TOKES | | 0.7 | 0.7 | 1.0 | 2.1 | 4.5 |
| KUOTA E PROJEKTIT | | 846.62 | 847.13 | | 847.19 | 847.13 |
| DIST. PJESORE E PROJEKTIT | | 0.5 | 2.5 | 2.5 | | |

SEKSIONI NR. : 284
 KUOTA PROJEKTIT : 846.884
 PROGRESIVA : 7075.000

SHKALLA 1:100

KUOTA REF. 844.137

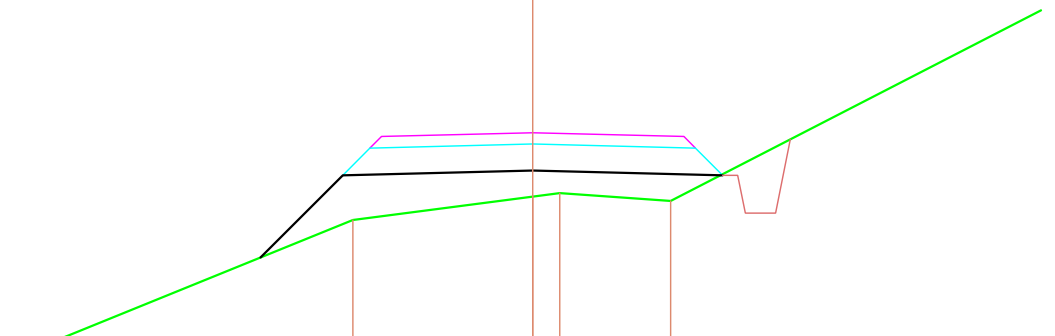

| | | | | | |
|---------------------------|-----|--------|--------|--------|--------|
| KUOTA E TOKES | | 845.73 | 846.04 | 846.08 | 845.98 |
| DIST. PJESORE E TOKES | 7.7 | | 2.4 | | |
| KUOTA E PROJEKTIT | | 845.23 | 846.32 | | |
| DIST. PJESORE E PROJEKTIT | | 1.1 | 2.5 | | |

| | | | | |
|--|--|--|---|---------|
| BASHKIA LIBOHOVE | | | OBJEKTI: RIPARIMIN DHE ASFALTIM I RRUGËS AUTOMOBILIS TIKE FUSHA E ÇAJUPIT – TOPOVË, PJESË E UNAZËS SË ZAGORISË L= 8971 ML. | Data: |
| | | | | 06/2024 |
| EMERTIMI I FLETES: PROFIL TERTHOR | | | SHK 1:1000 | |
| HARTOI: SEKTORI SHERBIMIT URBAN ARK. NELSON SEJDO | | | Nr. fleta 71 | |

SEKSIONI NR. : 285
 KUOTA PROJEKTIT : 847.090
 PROGRESIVA : 7100.000

SEKSIONI NR. : 287
 KUOTA PROJEKTIT : 847.727
 PROGRESIVA : 7150.000

SHKALLA 1:100

SHKALLA 1:100

KUOTA REF. 843.609

KUOTA REF. 843.958

| | | | | | | |
|---------------------------|-----|--------|--------|--------|--------|----------------------------|
| KUOTA E TOKES | | 846.45 | 846.44 | 846.43 | 846.48 | 849.57 849.59 849.78 |
| DIST. PJESORE E TOKES | 7.8 | 1.9 | 0.9 | 1.5 | 2.6 | 0.3 |
| KUOTA E PROJEKTIT | | 844.64 | 846.53 | 846.59 | 846.53 | |
| DIST. PJESORE E PROJEKTIT | | 1.9 | 2.5 | 2.5 | | |

| | | | | | | |
|---------------------------|-----|--------|--------|--------|------------------|--------|
| KUOTA E TOKES | | 842.44 | 844.68 | 845.81 | 846.87 846.85 | 846.98 |
| DIST. PJESORE E TOKES | 2.3 | 3.3 | 1.4 | 1.3 | 0.3 | 3.4 |
| KUOTA E PROJEKTIT | | 847.16 | 847.23 | | 847.16 846.89 | |
| DIST. PJESORE E PROJEKTIT | 5.5 | 2.5 | 2.5 | 0.3 | | |

SEKSIONI NR. : 286
 KUOTA PROJEKTIT : 847.409
 PROGRESIVA : 7125.000

SEKSIONI NR. : 288
 KUOTA PROJEKTIT : 847.956
 PROGRESIVA : 7175.000

SHKALLA 1:100

SHKALLA 1:100

KUOTA REF. 843.679

KUOTA REF. 846.534

| | | | | | | |
|---------------------------|-----|------------------|--------|------------------|--------|--------|
| KUOTA E TOKES | | 844.31 | 846.69 | 846.55 846.53 | 846.51 | 847.87 |
| DIST. PJESORE E TOKES | 3.1 | 2.7 | 0.4 | 1.4 | 3.4 | |
| KUOTA E PROJEKTIT | | 846.69 846.85 | 846.91 | 846.85 846.83 | | |
| DIST. PJESORE E PROJEKTIT | | 2.5 | 2.5 | | | |

| | | | | | |
|---------------------------|-----|------------------|------------------|--------|------------------|
| KUOTA E TOKES | | 847.57 | 847.87 847.89 | 847.98 | 848.21 848.69 |
| DIST. PJESORE E TOKES | 1.3 | | | | |
| KUOTA E PROJEKTIT | | 847.28 847.39 | | | |
| DIST. PJESORE E PROJEKTIT | 2.5 | | | | |



BASHKIA LIBOHOVE

OBJEKTI:
 RIPARIMIN DHE ASFALTIM I RRUGËS
 AUTOMOBILIS TIKE FUSHA E ÇAJUPIT – TOPOVË,
 PJESË E UNAZËS SË ZAGORISË L= 8971 ML.

Data:
 06/2024

EMERTIMI I FLETES:
 PROFIL TERTHOR

SHK
 1:1000

HARTOI: SEKTORI SHERBIMIT URBAN
 ARK. NELSON SEJDO

Nr. fleta
 72

SEKSIONI NR. : 289
 KUOTA PROJEKTIT : 847.058
 PROGRESIVA : 7200.000

SHKALLA 1:100

KUOTA REF. 844.825

| | | | | | | |
|---------------------------|--------|--------|--------|--------|--------|--------|
| KUOTA E TOKES | 844.40 | 846.62 | 846.73 | 846.99 | 847.03 | 847.52 |
| DIST. PJESORE E TOKES | 2.8 | 3.6 | 0.7 | 1.7 | 1.4 | 0.9 |
| KUOTA E PROJEKTIT | 844.10 | 846.50 | 846.56 | 846.50 | | |
| DIST. PJESORE E PROJEKTIT | | 2.4 | 2.5 | 2.5 | | |

SEKSIONI NR. : 291
 KUOTA PROJEKTIT : 843.585
 PROGRESIVA : 7250.000

SHKALLA 1:100

KUOTA REF. 841.406

| | | | | | | | |
|---------------------------|--------|--------|--------|--------|--------|--------|--------|
| KUOTA E TOKES | 842.78 | 842.97 | 842.92 | 842.83 | 842.82 | 842.90 | 843.35 |
| DIST. PJESORE E TOKES | 1.6 | 1.5 | 1.8 | 0.3 | 2.0 | 1.1 | 3.7 |
| KUOTA E PROJEKTIT | | 842.95 | 843.02 | 843.08 | | 843.02 | 843.00 |
| DIST. PJESORE E PROJEKTIT | | | 2.5 | 2.5 | | | |

SEKSIONI NR. : 290
 KUOTA PROJEKTIT : 845.159
 PROGRESIVA : 7225.000

SHKALLA 1:100

KUOTA REF. 843.160

| | | | | | |
|---------------------------|--------|--------|--------|--------|--------|
| KUOTA E TOKES | 844.68 | 844.66 | 844.57 | 844.59 | 844.81 |
| DIST. PJESORE E TOKES | 0.5 | 1.7 | 0.3 | 2.6 | 4.5 |
| KUOTA E PROJEKTIT | 844.66 | 844.60 | 844.66 | 844.60 | |
| DIST. PJESORE E PROJEKTIT | | 2.5 | 2.5 | | |

SEKSIONI NR. : 292
 KUOTA PROJEKTIT : 842.635
 PROGRESIVA : 7275.000

SHKALLA 1:100

KUOTA REF. 840.760

| | | | | | |
|---------------------------|--------|--------|--------|--------|--------|
| KUOTA E TOKES | 841.82 | 842.23 | 842.08 | 842.01 | 842.06 |
| DIST. PJESORE E TOKES | 3.7 | 2.4 | | | |
| KUOTA E PROJEKTIT | | 842.20 | 842.07 | | |
| DIST. PJESORE E PROJEKTIT | | 2.5 | | | |



BASHKIA LIBOHOVE
 OBJEKTI:
 RIPARIMIN DHE ASFALTIM I RRUGËS
 AUTOMOBILIS TIKE FUSHA E ÇAJUPIT – TOPOVË,
 PJESË E UNAZËS SË ZAGORISË L= 8971 ML.

Data:
06/2024

EMERTIMI I FLETES:
 PROFIL TERTHOR

SHK
1:1000

HARTOI: SEKTORI SHERBIMIT URBAN
 ARK. NELSON SEJDO

Nr. fleta
73

SEKSIONI NR. : 293
 KUOTA PROJEKTIT : 842.280
 PROGRESIVA : 7300.000

SEKSIONI NR. : 295
 KUOTA PROJEKTIT : 841.830
 PROGRESIVA : 7350.000

SHKALLA 1:100

SHKALLA 1:100

KUOTA REF. 839.091

KUOTA REF. 839.108

| | | | | | | |
|---------------------------|------------------|--------|--------|--------|--------|--------|
| KUOTA E TOKES | 841.93 | 841.77 | 841.70 | 841.81 | 841.86 | 842.07 |
| DIST. PJESORE E TOKES | 2.6 | 1.0 | 1.2 | 2.8 | 1.3 | |
| KUOTA E PROJEKTIT | 841.92 841.72 | 841.78 | | 841.72 | | |
| DIST. PJESORE E PROJEKTIT | 0.2 | 2.5 | 2.5 | | | |

| | | | | | | | |
|---------------------------|------------------|--------|--------|--------|--------|--------|--------|
| KUOTA E TOKES | 841.15 | 841.16 | 841.25 | 841.37 | 841.79 | 841.81 | 841.97 |
| DIST. PJESORE E TOKES | 0.9 | 0.9 | 0.7 | 2.3 | 0.2 | 1.0 | |
| KUOTA E PROJEKTIT | 841.14 841.27 | | | 841.33 | 841.27 | | |
| DIST. PJESORE E PROJEKTIT | | 2.5 | | 2.5 | | | |

SEKSIONI NR. : 294
 KUOTA PROJEKTIT : 842.071
 PROGRESIVA : 7325.000

SEKSIONI NR. : 296
 KUOTA PROJEKTIT : 841.111
 PROGRESIVA : 7375.000

SHKALLA 1:100

SHKALLA 1:100

KUOTA REF. 839.002

KUOTA REF. 839.538

| | | | | | | |
|---------------------------|------------------|--------|--------|--------|--------|--------|
| KUOTA E TOKES | 841.34 | 841.63 | 841.65 | 841.60 | 841.81 | 841.84 |
| DIST. PJESORE E TOKES | 3.5 | 1.2 | 0.5 | 2.4 | 1.4 | |
| KUOTA E PROJEKTIT | 841.56 841.51 | 841.57 | | 841.51 | | |
| DIST. PJESORE E PROJEKTIT | | 2.5 | 2.5 | | | |

| | | | | | | | |
|---------------------------|--------|------------------|--------|--------|--------|--------|--------|
| KUOTA E TOKES | 840.69 | 840.49 | 840.50 | 840.71 | 840.77 | 840.87 | 841.75 |
| DIST. PJESORE E TOKES | 3.0 | 0.4 | 2.3 | | | | |
| KUOTA E PROJEKTIT | | 840.49 840.55 | | | | | |
| DIST. PJESORE E PROJEKTIT | | 2.5 | | | | | |



| | |
|---|------------------|
| BASHKIA LIBOHOVE | |
| OBJEKTI: RIPARIMIN DHE ASFALTIM I RRUGËS AUTOMOBILIS TIKE FUSHA E ÇAJUPIT – TOPOVË, PJESË E UNAZËS SË ZAGORISË L= 8971 ML. | Data: 06/2024 |
| EMERTIMI I FLETES: PROFIL TERTHOR | SHK 1:1000 |
| HARTOI: SEKTORI SHERBIMIT URBAN ARK. NELSON SEJDO | Nr. fleta 74 |

SEKSIONI NR. : 297
 KUOTA PROJEKTIT : 839.767
 PROGRESIVA : 7400.000

SHKALLA 1:100

KUOTA REF. 837.449

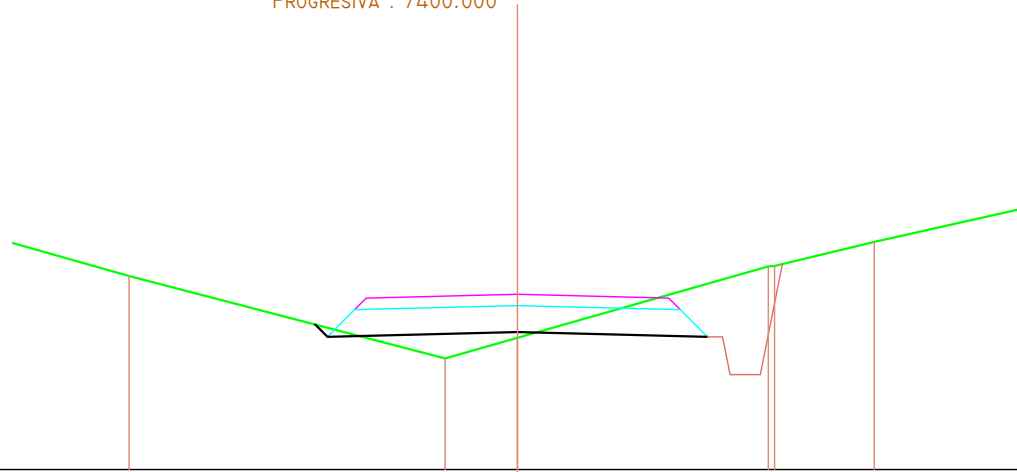

| | | | | | | |
|---------------------------|--------|--------|--------|--------|--------|--------|
| KUOTA E TOKES | 840.01 | 838.92 | 839.19 | 840.14 | 840.14 | 840.46 |
| DIST. PJESORE E TOKES | 4.2 | 1.0 | 3.3 | 1.3 | | |
| KUOTA E PROJEKTIT | | 839.37 | 839.27 | 839.20 | | |
| DIST. PJESORE E PROJEKTIT | | 0.7 | 2.5 | 2.5 | | |

SEKSIONI NR. : 299
 KUOTA PROJEKTIT : 836.508
 PROGRESIVA : 7450.000

SHKALLA 1:100

KUOTA REF. 833.603

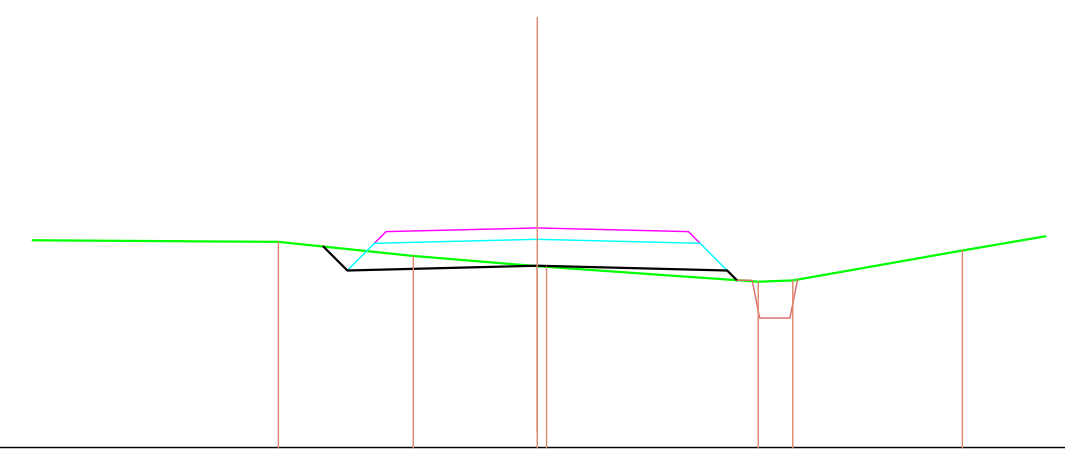

| | | | | | | | |
|---------------------------|--------|--------|--------|--------|--------|--------|--------|
| KUOTA E TOKES | 836.32 | 836.14 | 836.00 | 835.99 | 835.80 | 835.81 | 836.21 |
| DIST. PJESORE E TOKES | 1.8 | 1.6 | 2.8 | 0.5 | 2.2 | | |
| KUOTA E PROJEKTIT | 836.26 | 835.95 | 836.01 | | 835.95 | 835.82 | |
| DIST. PJESORE E PROJEKTIT | 0.3 | 2.5 | 2.5 | | | | |

SEKSIONI NR. : 298
 KUOTA PROJEKTIT : 838.137
 PROGRESIVA : 7425.000

SHKALLA 1:100

KUOTA REF. 835.530

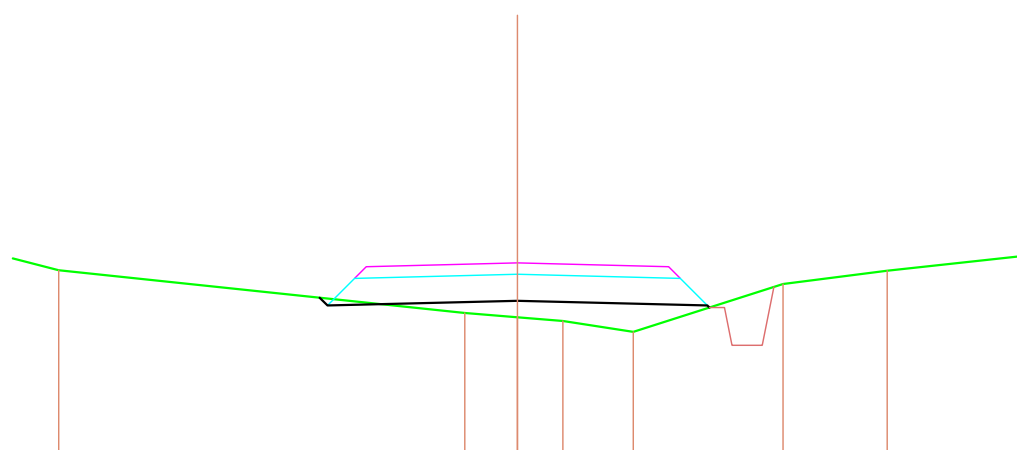

| | | | | | | | |
|---------------------------|--------|--------|--------|--------|--------|--------|--------|
| KUOTA E TOKES | 838.04 | 837.48 | 837.42 | 837.37 | 837.23 | 837.86 | 838.03 |
| DIST. PJESORE E TOKES | 5.4 | 0.7 | 0.6 | 0.9 | 2.0 | 1.4 | 2.6 |
| KUOTA E PROJEKTIT | | 837.68 | 837.64 | | 837.57 | 837.55 | |
| DIST. PJESORE E PROJEKTIT | | 2.5 | 2.5 | | | | |

SEKSIONI NR. : 300
 KUOTA PROJEKTIT : 835.196
 PROGRESIVA : 7475.000

SHKALLA 1:100

KUOTA REF. 832.540

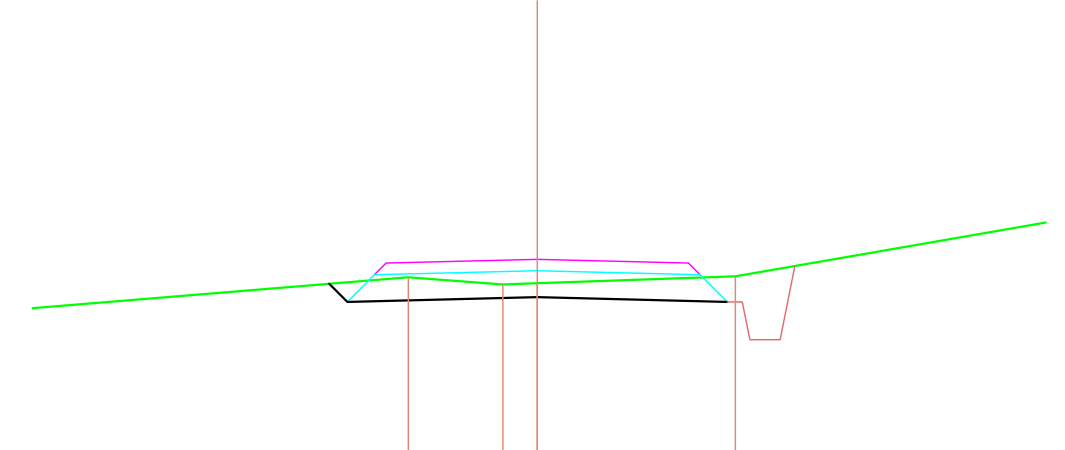

| | | | | |
|---------------------------|--------|--------|--------|--------|
| KUOTA E TOKES | 834.96 | 834.86 | 834.88 | 834.97 |
| DIST. PJESORE E TOKES | 1.3 | 0.5 | 2.6 | |
| KUOTA E PROJEKTIT | 834.87 | 834.65 | | |
| DIST. PJESORE E PROJEKTIT | 0.2 | 2.5 | | |



BASHKIA LIBOHOVE
 OBJEKTI:
 RIPARIMIN DHE ASFALTIM I RRUGËS
 AUTOMOBILIS TIKE FUSHA E ÇAJUPIT – TOPOVË,
 PJESË E UNAZËS SË ZAGORISË L= 8971 ML.

Data:
06/2024

EMERTIMI I FLETES:
 PROFIL TERTHOR

SHK
1:1000

HARTOI: SEKTORI SHERBIMIT URBAN
 ARK. NELSON SEJDO

Nr. fleta
75

SEKSIONI NR. : 301
 KUOTA PROJEKTIT : 835.344
 PROGRESIVA : 7500.000

SHKALLA 1:100

KUOTA REF. 831.803

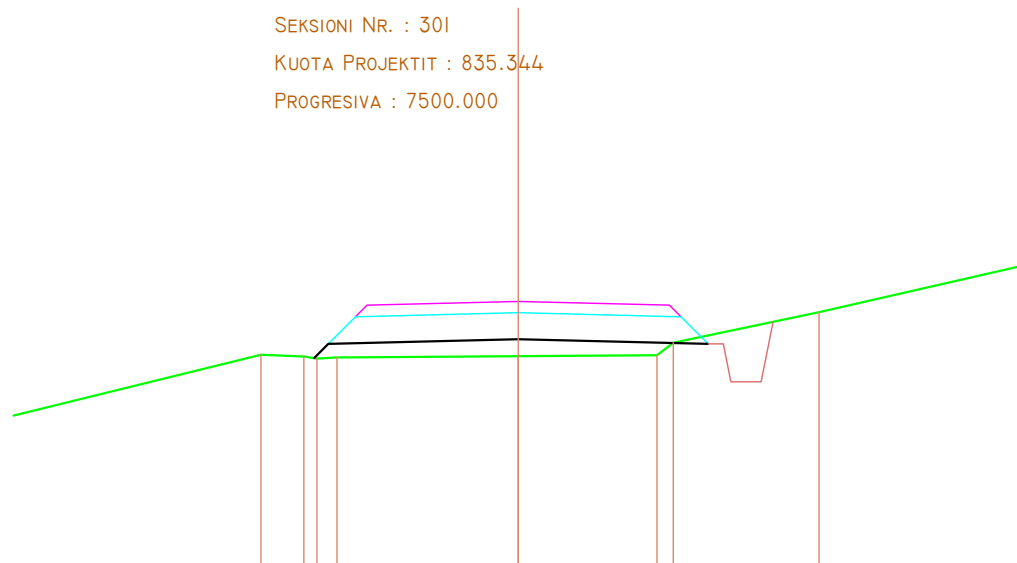

| | | | | | | | |
|---------------------------|--------|--------|--------|--------|--------|--------|--------|
| KUOTA E TOKES | 834.64 | 834.62 | 834.60 | 834.62 | 834.63 | 834.80 | 835.20 |
| DIST. PJESORE E TOKES | 0.6 | 0.2 | 0.3 | 2.4 | 1.8 | 0.2 | 1.9 |
| KUOTA E PROJEKTIT | 834.59 | 834.78 | 834.84 | 834.84 | 834.78 | | |
| DIST. PJESORE E PROJEKTIT | 0.2 | 2.5 | 2.5 | | | | |

SEKSIONI NR. : 303
 KUOTA PROJEKTIT : 835.863
 PROGRESIVA : 7550.000

SHKALLA 1:100

KUOTA REF. 833.518

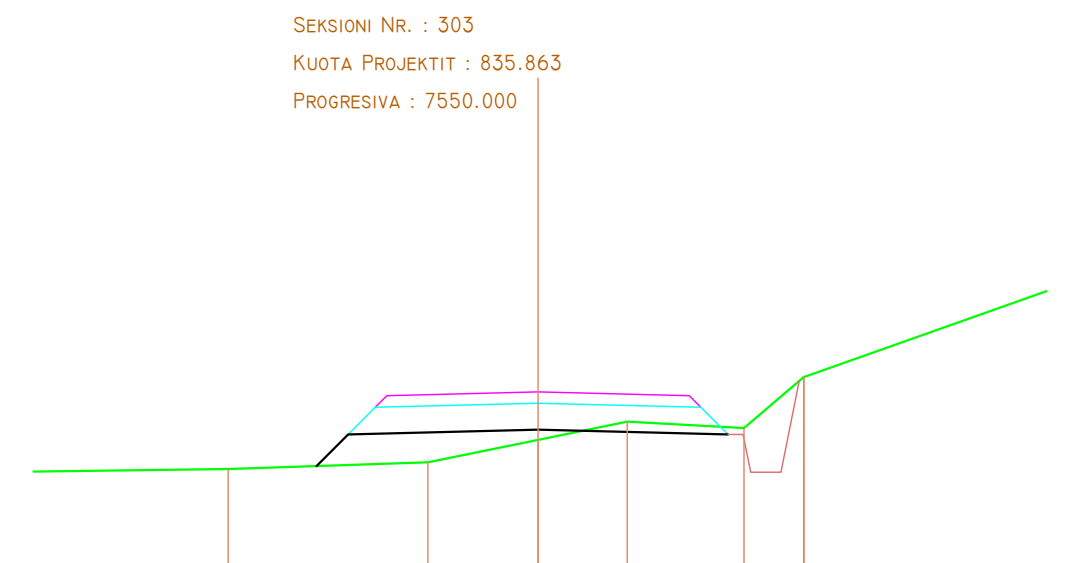

| | | | | | | | |
|---------------------------|--------|--------|--------|--------|--------|--------|--------|
| KUOTA E TOKES | 834.84 | 834.93 | 835.23 | 835.47 | 835.38 | 836.06 | 836.06 |
| DIST. PJESORE E TOKES | 2.6 | 1.5 | 1.2 | 1.5 | 0.8 | | 5.1 |
| KUOTA E PROJEKTIT | 834.88 | 835.30 | 835.36 | 835.30 | 835.30 | | |
| DIST. PJESORE E PROJEKTIT | 0.4 | 2.5 | 2.5 | | | | |

SEKSIONI NR. : 302
 KUOTA PROJEKTIT : 836.548
 PROGRESIVA : 7525.000

SHKALLA 1:100

KUOTA REF. 834.459

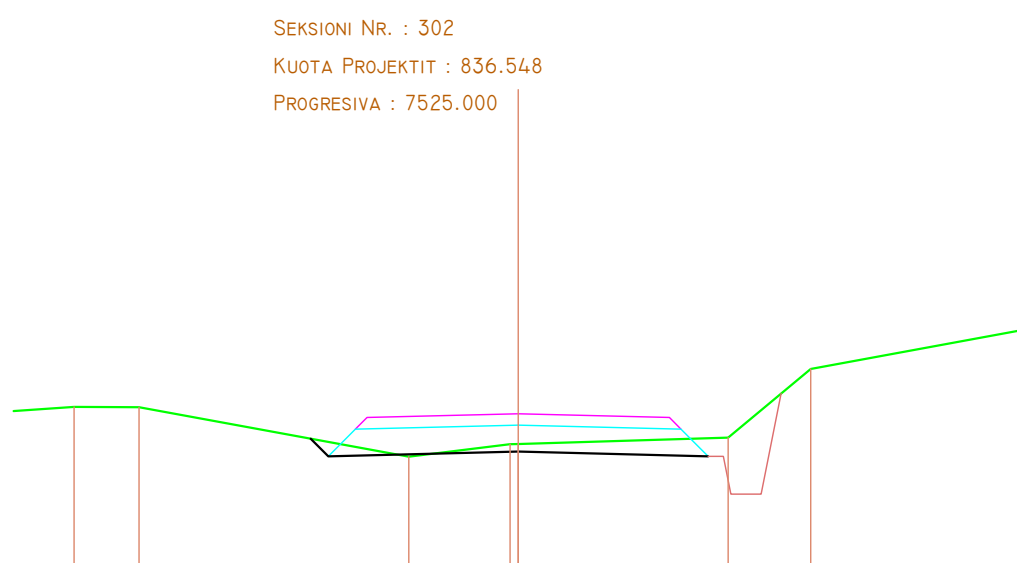

| | | | | | | | |
|---------------------------|--------|--------|--------|--------|--------|--------|--------|
| KUOTA E TOKES | 836.64 | 836.64 | 835.98 | 836.14 | 836.15 | 836.23 | 837.14 |
| DIST. PJESORE E TOKES | 0.9 | 3.6 | 1.3 | 2.8 | 1.1 | | |
| KUOTA E PROJEKTIT | 836.22 | 835.99 | 836.05 | 835.99 | | | |
| DIST. PJESORE E PROJEKTIT | 0.2 | 2.5 | 2.5 | | | | |

SEKSIONI NR. : 304
 KUOTA PROJEKTIT : 834.415
 PROGRESIVA : 7575.000

SHKALLA 1:100

KUOTA REF. 831.794

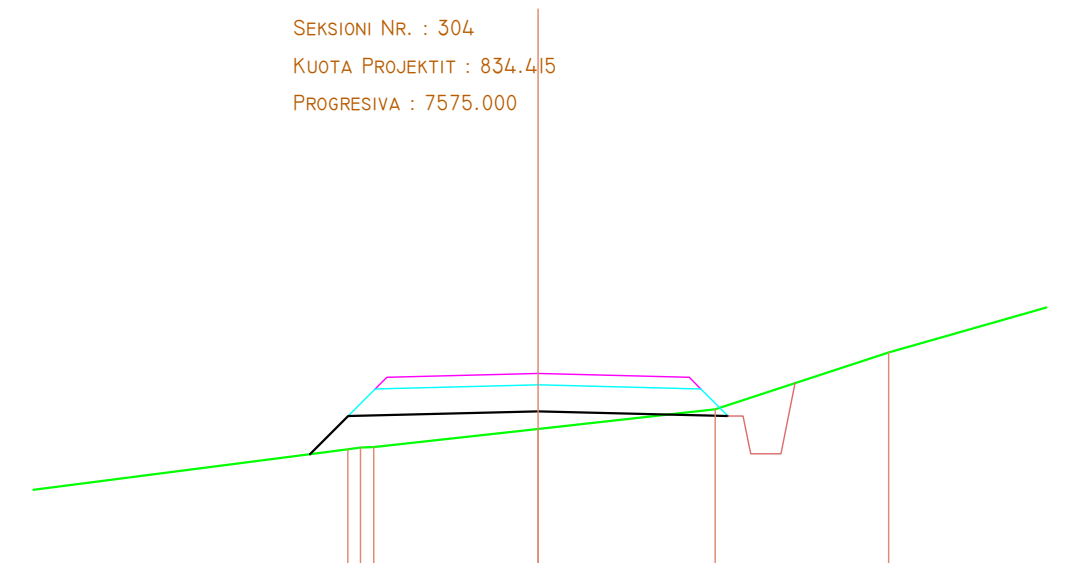

| | | | | | | |
|---------------------------|--------|--------|--------|--------|--------|--------|
| KUOTA E TOKES | 833.41 | 833.45 | 833.44 | 833.68 | 833.94 | 834.69 |
| DIST. PJESORE E TOKES | 6.7 | 0.2 | 0.2 | 2.2 | | |
| KUOTA E PROJEKTIT | 833.35 | 833.85 | 833.44 | 833.68 | 833.94 | 834.69 |
| DIST. PJESORE E PROJEKTIT | 0.5 | 2.5 | | | | |



BASHKIA LIBOHOVE
 OBJEKTI:
 RIPARIMIN DHE ASFALTIM I RRUGËS
 AUTOMOBILIS TIKE FUSHA E ÇAJUPIT – TOPOVË,
 PJESË E UNAZËS SË ZAGORISË L= 8971 ML.

Data:

06/2024

EMERTIMI I FLETES:
 PROFIL TERTHOR

SHK
 1:1000

HARTOI: SEKTORI SHERBIMIT URBAN
 ARK. NELSON SEJDO

Nr. fleta

76

SEKSIONI NR. : 305
 KUOTA PROJEKTIT : 832.806
 PROGRESIVA : 7600.000

SEKSIONI NR. : 307
 KUOTA PROJEKTIT : 828.784
 PROGRESIVA : 7650.000

SHKALLA 1:100

SHKALLA 1:100

KUOTA REF. 830.269

KUOTA REF. 826.067

| | | | | | |
|---------------------------|--------|--------|--------|--------|--------|
| KUOTA E TOKES | 830.46 | 832.25 | 832.46 | 832.47 | 832.53 |
| DIST. PJESORE E TOKES | 4.1 | 1.2 | 0.3 | 2.0 | 6.6 |
| KUOTA E PROJEKTIT | 831.52 | 832.24 | 832.31 | 832.24 | |
| DIST. PJESORE E PROJEKTIT | 0.7 | 2.5 | 2.5 | | |

| | | | | | |
|---------------------------|--------|--------|--------|--------|--------|
| KUOTA E TOKES | 828.23 | 828.43 | 828.45 | 828.55 | 831.20 |
| DIST. PJESORE E TOKES | 8.4 | 1.8 | 0.2 | 1.5 | 4.5 |
| KUOTA E PROJEKTIT | 827.75 | 828.22 | 828.28 | 828.22 | |
| DIST. PJESORE E PROJEKTIT | 0.5 | 2.5 | 2.5 | | |

SEKSIONI NR. : 306
 KUOTA PROJEKTIT : 830.139
 PROGRESIVA : 7625.000

SEKSIONI NR. : 308
 KUOTA PROJEKTIT : 827.613
 PROGRESIVA : 7675.000

SHKALLA 1:100

SHKALLA 1:100

KUOTA REF. 827.030

KUOTA REF. 825.374

| | | | | | |
|---------------------------|--------|--------|--------|--------|--------|
| KUOTA E TOKES | 829.22 | 829.28 | 829.34 | 829.37 | 831.26 |
| DIST. PJESORE E TOKES | 6.1 | 0.8 | 0.7 | 1.6 | 1.9 |
| KUOTA E PROJEKTIT | 828.09 | 829.58 | 829.64 | 829.58 | 829.56 |
| DIST. PJESORE E PROJEKTIT | 1.5 | 2.5 | 2.5 | | |

| | | | | | | | |
|---------------------------|--------|--------|--------|--------|--------|--------|--------|
| KUOTA E TOKES | 826.55 | 827.00 | 827.08 | 827.10 | 827.14 | 827.95 | 828.65 |
| DIST. PJESORE E TOKES | 1.2 | 2.7 | | | | | |
| KUOTA E PROJEKTIT | 827.00 | 827.05 | | | | | |
| DIST. PJESORE E PROJEKTIT | | 2.5 | | | | | |



BASHKIA LIBOHOVE
 OBJEKTI:
 RIPARIMIN DHE ASFALTIM I RRUGËS
 AUTOMOBILIS TIKE FUSHA E ÇAJUPIT – TOPOVË,
 PJESË E UNAZËS SË ZAGORISË L= 8971 ML.

Data:
06/2024

EMERTIMI I FLETES:
 PROFIL TERTHOR

SHK
1:1000

HARTOI: SEKTORI SHERBIMIT URBAN
 ARK. NELSON SEJDO

Nr. fleta
77

SEKSIONI NR. : 309
 KUOTA PROJEKTIT : 826.351
 PROGRESIVA : 7700.000

SEKSIONI NR. : 311
 KUOTA PROJEKTIT : 822.500
 PROGRESIVA : 7750.000

SHKALLA 1:100

SHKALLA 1:100

KUOTA REF. 824.633

KUOTA REF. 819.361

| | | | | |
|---------------------------|------------------|------------------|------------------|--------|
| KUOTA E TOKES | 825.16 | 825.90 825.69 | 825.86 | 825.68 |
| DIST. PJESORE E TOKES | 3.0 | 0.2 0.6 | 2.3 | |
| KUOTA E PROJEKTIT | 825.21 825.79 | 825.85 | 825.79 825.70 | |
| DIST. PJESORE E PROJEKTIT | 0.6 | 2.5 | 2.5 | |

| | | | | |
|---------------------------|------------------|--------|------------------|--------|
| KUOTA E TOKES | 821.86 | 821.94 | 822.00 822.01 | 822.79 |
| DIST. PJESORE E TOKES | 1.5 | 1.2 | 0.5 1.4 | |
| KUOTA E PROJEKTIT | 821.00 821.94 | 822.00 | 821.94 | |
| DIST. PJESORE E PROJEKTIT | 0.9 | 2.5 | 2.5 | |

SEKSIONI NR. : 310
 KUOTA PROJEKTIT : 824.536
 PROGRESIVA : 7725.000

SEKSIONI NR. : 312
 KUOTA PROJEKTIT : 820.463
 PROGRESIVA : 7775.000

SHKALLA 1:100

SHKALLA 1:100

KUOTA REF. 821.400

KUOTA REF. 817.685

| | | | |
|---------------------------|------------------|----------------------------|------------------|
| KUOTA E TOKES | 823.32 | 823.95 824.03 824.04 | 823.90 824.08 |
| DIST. PJESORE E TOKES | 1.8 | 0.3 0.2 | 3.1 0.3 |
| KUOTA E PROJEKTIT | 822.62 823.97 | 824.04 | 823.97 823.94 |
| DIST. PJESORE E PROJEKTIT | 1.4 | 2.5 | 2.5 |

| | | | | |
|---------------------------|------------------|------------------|--------|--------|
| KUOTA E TOKES | 819.78 | 819.72 819.70 | 819.63 | 820.92 |
| DIST. PJESORE E TOKES | 1.1 | | | |
| KUOTA E PROJEKTIT | 818.89 819.90 | | | |
| DIST. PJESORE E PROJEKTIT | 1.0 | 2.5 | | |



BASHKIA LIBOHOVE

OBJEKTI:
 RIPARIMIN DHE ASFALTIM I RRUGËS
 AUTOMOBILIS TIKE FUSHA E ÇAJUPIT – TOPOVË,
 PJESË E UNAZËS SË ZAGORISË L= 8971 ML.

Data:

06/2024

EMERTIMI I FLETES:

PROFIL TERTHOR

SHK
 1:1000

HARTOI: SEKTORI SHERBIMIT URBAN
 ARK. NELSON SEJDO

Nr. fleta

78

SEKSIONI NR. : 313
 KUOTA PROJEKTIT : 818.426
 PROGRESIVA : 7800.000

SEKSIONI NR. : 315
 KUOTA PROJEKTIT : 814.045
 PROGRESIVA : 7850.000

SHKALLA 1:100

SHKALLA 1:100

KUOTA REF. 815.408

KUOTA REF. 812.267

| | | | | | | |
|---------------------------|--------|--------|--------|--------|--------|--------|
| KUOTA E TOKES | 816.35 | 817.05 | 818.08 | 818.02 | 817.95 | 817.64 |
| DIST. PJESORE E TOKES | 1.2 | 2.8 | 0.8 | 0.3 | 1.6 | |
| KUOTA E PROJEKTIT | | 817.38 | 817.86 | 817.95 | 817.86 | |
| DIST. PJESORE E PROJEKTIT | | 0.5 | 2.5 | 2.5 | | |

| | | | | | |
|---------------------------|--------|--------|--------|--------|--------|
| KUOTA E TOKES | 813.35 | 813.47 | 813.40 | 813.22 | 816.80 |
| DIST. PJESORE E TOKES | 5.4 | 1.0 | 0.6 | 1.6 | 3.1 |
| KUOTA E PROJEKTIT | 812.59 | 813.48 | 813.55 | 813.48 | |
| DIST. PJESORE E PROJEKTIT | 0.9 | 2.5 | 2.5 | | |

SEKSIONI NR. : 314
 KUOTA PROJEKTIT : 816.389
 PROGRESIVA : 7825.000

SEKSIONI NR. : 316
 KUOTA PROJEKTIT : 810.791
 PROGRESIVA : 7875.000

SHKALLA 1:100

SHKALLA 1:100

KUOTA REF. 814.566

KUOTA REF. 811.621

| | | | | | |
|---------------------------|--------|--------|--------|--------|--------|
| KUOTA E TOKES | 815.67 | 815.58 | 815.60 | 815.75 | 817.07 |
| DIST. PJESORE E TOKES | 7.8 | 1.5 | 0.3 | 2.0 | 0.5 |
| KUOTA E PROJEKTIT | 814.51 | 815.83 | 815.89 | 815.83 | |
| DIST. PJESORE E PROJEKTIT | 1.3 | 2.5 | 2.5 | | |

| | | | | | |
|---------------------------|--------|--------|--------|--------|--------|
| KUOTA E TOKES | 809.66 | 809.77 | 809.78 | 809.85 | 812.06 |
| DIST. PJESORE E TOKES | 4.6 | 3.1 | | | |
| KUOTA E PROJEKTIT | 809.67 | 810.23 | | | |
| DIST. PJESORE E PROJEKTIT | 0.6 | 2.5 | | | |



BASHKIA LIBOHOVE

OBJEKTI:
 RIPARIMIN DHE ASFALTIM I RRUGËS
 AUTOMOBILIS TIKE FUSHA E ÇAJUPIT – TOPOVË,
 PJESË E UNAZËS SË ZAGORISË L= 8971 ML.

Data:
 06/2024

EMERTIMI I FLETES:
 PROFIL TERTHOR

SHK
 1:1000

HARTOI: SEKTORI SHERBIMIT URBAN
 ARK. NELSON SEJDO

Nr. fleta
 79

SEKSIONI NR. : 317
 KUOTA PROJEKTIT : 809.721
 PROGRESIVA : 7900.000

SEKSIONI NR. : 319
 KUOTA PROJEKTIT : 809.134
 PROGRESIVA : 7950.000

SHKALLA 1:100

SHKALLA 1:100

KUOTA REF. 811.301

KUOTA REF. 807.372

| | | | | | | | |
|---------------------------|-----|------------------|--------|--------|--------|--------|-----|
| KUOTA E TOKES | | 809.05 | 809.09 | 809.14 | 809.21 | 809.14 | |
| DIST. PJESORE E TOKES | 7.2 | | 1.8 | 0.8 | 1.1 | 1.8 | 7.4 |
| KUOTA E PROJEKTIT | | 809.05 809.16 | | 809.22 | | 809.16 | |
| DIST. PJESORE E PROJEKTIT | | | 2.5 | | 2.5 | | |

| | | | | | | |
|---------------------------|--|--------|--------|------------------|--------|--|
| KUOTA E TOKES | | 806.44 | 807.84 | 808.68 808.70 | 809.16 | |
| DIST. PJESORE E TOKES | | 2.2 | 2.5 | 2.0 | | |
| KUOTA E PROJEKTIT | | 806.73 | 808.57 | 808.65 | 808.57 | |
| DIST. PJESORE E PROJEKTIT | | 1.8 | 2.5 | 2.5 | | |

SEKSIONI NR. : 318
 KUOTA PROJEKTIT : 809.707
 PROGRESIVA : 7925.000

SEKSIONI NR. : 320
 KUOTA PROJEKTIT : 808.427
 PROGRESIVA : 7975.000

SHKALLA 1:100

SHKALLA 1:100

KUOTA REF. 807.156

KUOTA REF. 808.622

| | | | | | | |
|---------------------------|--|------------------|--------|--------|--------|--------|
| KUOTA E TOKES | | 809.19 | 809.36 | 809.59 | 809.45 | 811.22 |
| DIST. PJESORE E TOKES | | | 1.1 | 0.8 | 1.9 | 4.4 |
| KUOTA E PROJEKTIT | | 808.36 809.14 | | 809.21 | 809.14 | |
| DIST. PJESORE E PROJEKTIT | | 0.8 | 2.5 | 2.5 | | |

| | | | | | | |
|---------------------------|--|--------|--------|--------|--------|--|
| KUOTA E TOKES | | 807.75 | 807.80 | 807.90 | 808.17 | |
| DIST. PJESORE E TOKES | | 5.3 | 0.8 | 1.0 | 2.4 | |
| KUOTA E PROJEKTIT | | 806.54 | 807.86 | | | |
| DIST. PJESORE E PROJEKTIT | | 1.3 | 2.5 | | | |



BASHKIA LIBOHOVE

OBJEKTI:
 RIPARIMIN DHE ASFALTIM I RRUGËS
 AUTOMOBILIS TIKE FUSHA E ÇAJUPIT – TOPOVË,
 PJESË E UNAZËS SË ZAGORISË L= 8971 ML.

Data:
 06/2024

EMERTIMI I FLETES:
 PROFIL TERTHOR

SHK
 1:1000

HARTOI: SEKTORI SHERBIMIT URBAN
 ARK. NELSON SEJDO

Nr. fleta
 80

SEKSIONI NR. : 321
 KUOTA PROJEKTIT : 807.719
 PROGRESIVA : 8000.000

SEKSIONI NR. : 323
 KUOTA PROJEKTIT : 806.304
 PROGRESIVA : 8050.000

SHKALLA 1:100

SHKALLA 1:100

KUOTA REF. 809.035

KUOTA REF. 805.006

| | | | | | |
|---------------------------|--------|------------------|--------|--------|--------|
| KUOTA E TOKES | 805.50 | 806.66 806.67 | 807.16 | 807.32 | 807.16 |
| DIST. PJESORE E TOKES | 2.2 | 2.8 | 0.9 | | |
| KUOTA E PROJEKTIT | 806.82 | 807.16 | 807.22 | 807.16 | |
| DIST. PJESORE E PROJEKTIT | | 0.6 | 2.5 | 2.5 | |

| | | | | | | |
|---------------------------|--------|------------------|--------|------------------|--------|--------|
| KUOTA E TOKES | 803.93 | 805.55 | 805.70 | 805.77 805.77 | 805.77 | 806.56 |
| DIST. PJESORE E TOKES | 2.6 | 2.0 | 0.9 | 0.9 | 1.3 | |
| KUOTA E PROJEKTIT | | 805.57 805.74 | | 805.80 | | 805.74 |
| DIST. PJESORE E PROJEKTIT | | 0.2 | 2.5 | 2.5 | | |

SEKSIONI NR. : 322
 KUOTA PROJEKTIT : 807.011
 PROGRESIVA : 8025.000

SEKSIONI NR. : 324
 KUOTA PROJEKTIT : 805.934
 PROGRESIVA : 8075.000

SHKALLA 1:100

SHKALLA 1:100

KUOTA REF. 807.331

KUOTA REF. 805.293

| | | | | | |
|---------------------------|--------|------------------|--------|--------|--------|
| KUOTA E TOKES | 804.89 | 805.93 805.92 | 806.44 | 806.59 | 806.45 |
| DIST. PJESORE E TOKES | 1.6 | 0.2 | 2.5 | 0.7 | 7.6 |
| KUOTA E PROJEKTIT | 805.39 | 806.45 | 806.51 | 806.45 | |
| DIST. PJESORE E PROJEKTIT | | 1.1 | 2.5 | 2.5 | |

| | | | | |
|---------------------------|--------|--------|--------|--------|
| KUOTA E TOKES | 805.12 | 805.14 | 805.15 | 805.17 |
| DIST. PJESORE E TOKES | 5.5 | 1.7 | 0.7 | |
| KUOTA E PROJEKTIT | 805.00 | 805.37 | | |
| DIST. PJESORE E PROJEKTIT | 0.4 | 2.5 | | |



BASHKIA LIBOHOVE

OBJEKTI:
 RIPARIMIN DHE ASFALTIM I RRUGËS
 AUTOMOBILIS TIKE FUSHA E ÇAJUPIT – TOPOVË,
 PJESË E UNAZËS SË ZAGORISË L= 8971 ML.

Data:
 06/2024

EMERTIMI I FLETES:
 PROFIL TERTHOR

SHK
 1:1000

HARTOI: SEKTORI SHERBIMIT URBAN
 ARK. NELSON SEJDO

Nr. fleta
 81

SEKSIONI NR. : 325
 KUOTA PROJEKTIT : 807.584
 PROGRESIVA : 8100.000

SEKSIONI NR. : 327
 KUOTA PROJEKTIT : 810.096
 PROGRESIVA : 8150.000

SHKALLA 1:100

SHKALLA 1:100

KUOTA REF. 807.869

KUOTA REF. 808.681

| | | | | | |
|---------------------------|--------|--------|--------|--------|--------|
| KUOTA E TOKES | 806.52 | 807.19 | 807.27 | 807.58 | 800.91 |
| DIST. PJESORE E TOKES | | 3.2 | 0.4 | 0.2 | 3.2 |
| KUOTA E PROJEKTIT | 806.56 | 807.02 | 807.08 | 807.02 | |
| DIST. PJESORE E PROJEKTIT | 0.5 | 2.5 | 2.5 | | |

| | | | | | |
|---------------------------|--------|--------|--------|--------|--------|
| KUOTA E TOKES | 807.54 | 809.34 | 809.44 | 809.54 | 809.77 |
| DIST. PJESORE E TOKES | 5.5 | 1.2 | 1.4 | 1.9 | 3.8 |
| KUOTA E PROJEKTIT | 808.61 | 809.53 | 809.60 | 809.53 | |
| DIST. PJESORE E PROJEKTIT | 0.9 | 2.5 | 2.5 | | |

SEKSIONI NR. : 326
 KUOTA PROJEKTIT : 808.849
 PROGRESIVA : 8125.000

SEKSIONI NR. : 328
 KUOTA PROJEKTIT : 811.774
 PROGRESIVA : 8175.000

SHKALLA 1:100

SHKALLA 1:100

KUOTA REF. 808.348

KUOTA REF. 809.665

| | | | | | |
|---------------------------|--------|--------|--------|--------|--------|
| KUOTA E TOKES | 807.59 | 808.27 | 808.47 | 808.57 | 808.63 |
| DIST. PJESORE E TOKES | 3.0 | 1.8 | 0.9 | 1.4 | |
| KUOTA E PROJEKTIT | 808.06 | 808.29 | 808.35 | 808.29 | |
| DIST. PJESORE E PROJEKTIT | 0.2 | 2.5 | 2.5 | | |

| | | | | | | |
|---------------------------|--------|--------|--------|--------|--------|--------|
| KUOTA E TOKES | 810.64 | 810.66 | 810.70 | 810.92 | 811.20 | 812.23 |
| DIST. PJESORE E TOKES | 0.6 | 1.7 | | | | |
| KUOTA E PROJEKTIT | 810.07 | 811.21 | | | | |
| DIST. PJESORE E PROJEKTIT | 1.1 | 2.5 | | | | |



BASHKIA LIBOHOVE
 OBJEKTI:
 RIPARIMIN DHE ASFALTIM I RRUGËS
 AUTOMOBILIS TIKE FUSHA E ÇAJUPIT – TOPOVË,
 PJESË E UNAZËS SË ZAGORISË L= 8971 ML.

EMERTIMI I FLETES:
 PROFIL TERTHOR

HARTOI: SEKTORI SHERBIMIT URBAN
 ARK. NELSON SEJDO

Data:
 06/2024
 SHK
 1:1000
 Nr. fleta
 82

SEKSIONI NR. : 329
 KUOTA PROJEKTIT : 813.645
 PROGRESIVA : 8200.000

SEKSIONI NR. : 331
 KUOTA PROJEKTIT : 816.041
 PROGRESIVA : 8250.000

SHKALLA 1:100

SHKALLA 1:100

KUOTA REF. 812.203

KUOTA REF. 814.906

| | | | | | |
|---------------------------|----------------------------|------------------|--------|--------|------|
| KUOTA E TOKES | 812.42 812.43 812.43 | 812.81 812.82 | 813.02 | 813.10 | |
| DIST. PJESORE E TOKES | 1.5 | 2.8 | 1.0 | | 10.4 |
| KUOTA E PROJEKTIT | | 812.82 813.08 | 813.14 | 813.08 | |
| DIST. PJESORE E PROJEKTIT | | 0.3 | 2.5 | 2.5 | |

| | | | | | |
|---------------------------|------------------|------------------|--------|-----|-----|
| KUOTA E TOKES | 815.59 | 815.72 815.74 | 815.82 | | |
| DIST. PJESORE E TOKES | 5.5 | 1.8 | 0.4 | 1.9 | 5.2 |
| KUOTA E PROJEKTIT | 815.46 815.48 | 815.54 | 815.48 | | |
| DIST. PJESORE E PROJEKTIT | | 2.5 | 2.5 | | |

SEKSIONI NR. : 330
 KUOTA PROJEKTIT : 815.379
 PROGRESIVA : 8225.000

SEKSIONI NR. : 332
 KUOTA PROJEKTIT : 815.465
 PROGRESIVA : 8275.000

SHKALLA 1:100

SHKALLA 1:100

KUOTA REF. 814.846

KUOTA REF. 814.750

| | | | | | | |
|---------------------------|--------|------------------|--------|--------|--------|-----|
| KUOTA E TOKES | 813.74 | 814.81 814.90 | 815.00 | 815.14 | 815.31 | |
| DIST. PJESORE E TOKES | 4.3 | 0.2 | 0.8 | 1.4 | 1.7 | 7.7 |
| KUOTA E PROJEKTIT | | 814.77 814.82 | 814.88 | 814.82 | | |
| DIST. PJESORE E PROJEKTIT | | | 2.5 | 2.5 | | |

| | | | | |
|---------------------------|------------------|------------------|--------|--|
| KUOTA E TOKES | 814.98 | 815.18 815.19 | 815.22 | |
| DIST. PJESORE E TOKES | 8.1 | 1.6 | 0.4 | |
| KUOTA E PROJEKTIT | 814.86 814.90 | | | |
| DIST. PJESORE E PROJEKTIT | | 2.5 | | |



BASHKIA LIBOHOVE

OBJEKTI:
 RIPARIMIN DHE ASFALTIM I RRUGËS
 AUTOMOBILIS TIKE FUSHA E ÇAJUPIT – TOPOVË,
 PJESË E UNAZËS SË ZAGORISË L= 8971 ML.

Data:
 06/2024

EMERTIMI I FLETES:
 PROFIL TERTHOR

SHK
 1:1000

HARTOI: SEKTORI SHERBIMIT URBAN
 ARK. NELSON SEJDO

Nr. fleta
 83

SEKSIONI NR. : 333
 KUOTA PROJEKTIT : 814.597
 PROGRESIVA : 8300.000

SEKSIONI NR. : 335
 KUOTA PROJEKTIT : 818.413
 PROGRESIVA : 8350.000

SHKALLA 1:100

SHKALLA 1:100

KUOTA REF. 814.705

KUOTA REF. 814.859

| | | | | | | |
|---------------------------|-----|------------------|--------|--------|--------|--|
| KUOTA E TOKES | | 814.02 | 814.10 | 814.15 | 816.23 | |
| DIST. PJESORE E TOKES | 5.4 | 1.9 | 1.1 | 1.3 | 3.1 | |
| KUOTA E PROJEKTIT | | 813.99 814.05 | 814.10 | 814.05 | | |
| DIST. PJESORE E PROJEKTIT | | | 2.5 | 2.5 | | |

| | | | | | | | |
|---------------------------|--|--------|--------|------------------|--------|--------|--|
| KUOTA E TOKES | | 817.08 | 817.48 | 818.37 818.37 | 818.29 | 818.11 | |
| DIST. PJESORE E TOKES | | 1.4 | 4.0 | 1.1 | 2.2 | 6.9 | |
| KUOTA E PROJEKTIT | | | | 818.02 817.85 | 817.91 | 817.85 | |
| DIST. PJESORE E PROJEKTIT | | | | 2.5 | 2.5 | | |

SEKSIONI NR. : 334
 KUOTA PROJEKTIT : 816.568
 PROGRESIVA : 8325.000

SEKSIONI NR. : 336
 KUOTA PROJEKTIT : 818.696
 PROGRESIVA : 8375.000

SHKALLA 1:100

SHKALLA 1:100

KUOTA REF. 813.680

KUOTA REF. 816.295

| | | | | | | |
|---------------------------|-----|------------------|--------|----------------------------|--------|--|
| KUOTA E TOKES | | 815.86 | 815.80 | 815.78 815.75 816.30 | 816.52 | |
| DIST. PJESORE E TOKES | 7.9 | 2.2 | 0.8 | 0.3 0.4 | 3.5 | |
| KUOTA E PROJEKTIT | | 815.84 816.01 | 816.07 | 816.01 | | |
| DIST. PJESORE E PROJEKTIT | | | 2.5 | 2.5 | | |

| | | | | | | | | | |
|---------------------------|--|--------|--------|--------|--------|--------|--------|--------|--------|
| KUOTA E TOKES | | 817.12 | 817.49 | 817.62 | 817.86 | 818.00 | 818.12 | 818.33 | 819.77 |
| DIST. PJESORE E TOKES | | 1.4 | 0.8 | 1.1 | 0.8 | 0.9 | | | |
| KUOTA E PROJEKTIT | | | | 817.57 | 818.13 | | | | |
| DIST. PJESORE E PROJEKTIT | | | | 0.6 | 2.5 | | | | |



BASHKIA LIBOHOVE
 OBJEKTI:
 RIPARIMIN DHE ASFALTIM I RRUGËS
 AUTOMOBILIS TIKE FUSHA E ÇAJUPIT – TOPOVË,
 PJESË E UNAZËS SË ZAGORISË L= 8971 ML.

EMERTIMI I FLETES:
 PROFIL TERTHOR

HARTOI: SEKTORI SHERBIMIT URBAN
 ARK. NELSON SEJDO

Data:
 06/2024
 SHK
 1:1000
 Nr. fleta
 84

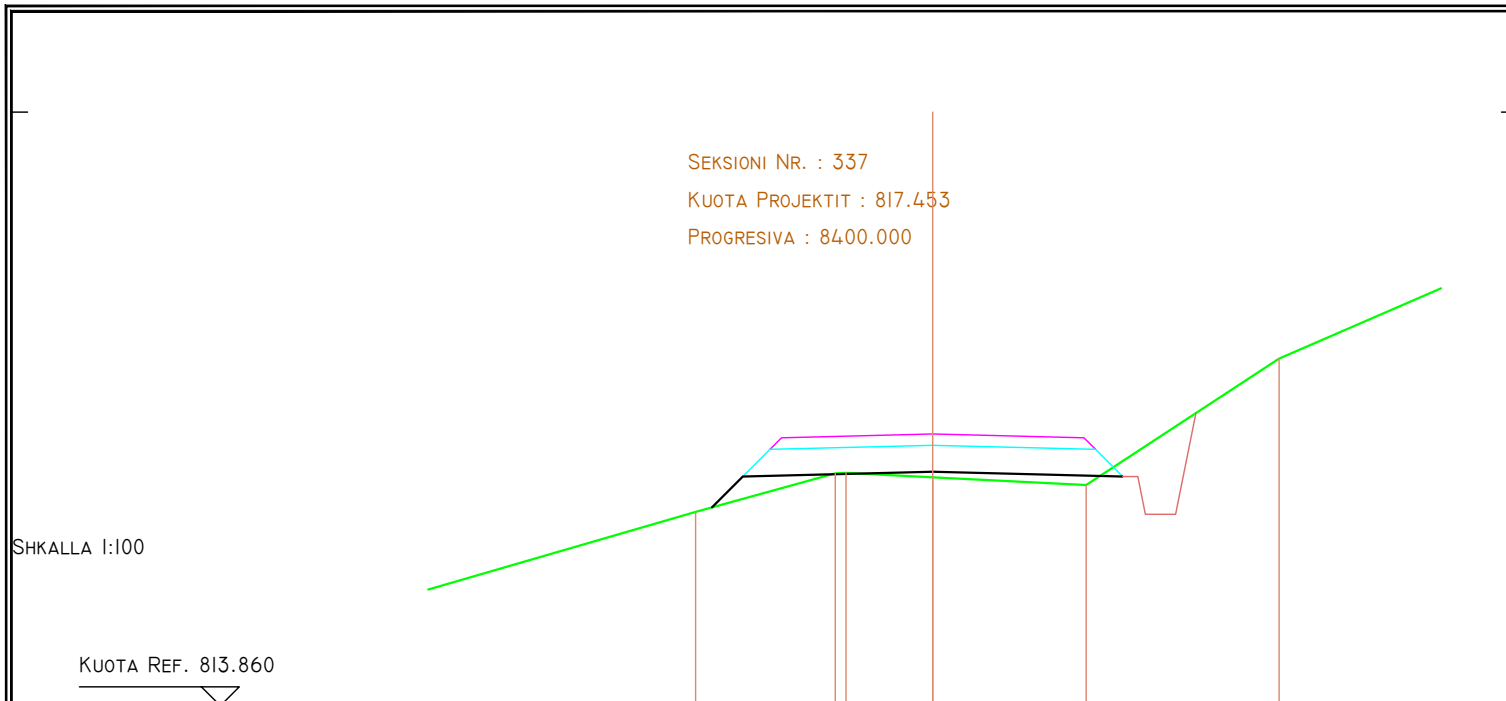

| | | | | | |
|---------------------------|------------------|------------------|--------|--------|--------|
| KUOTA E TOKES | 816.42 | 816.93 816.94 | 816.88 | 816.78 | 818.45 |
| DIST. PJESORE E TOKES | 1.8 | 1.1 | 2.0 | 2.6 | 4.0 |
| KUOTA E PROJEKTIT | 816.48 816.89 | 816.95 | 816.89 | | |
| DIST. PJESORE E PROJEKTIT | 0.4 | 2.5 | 2.5 | | |

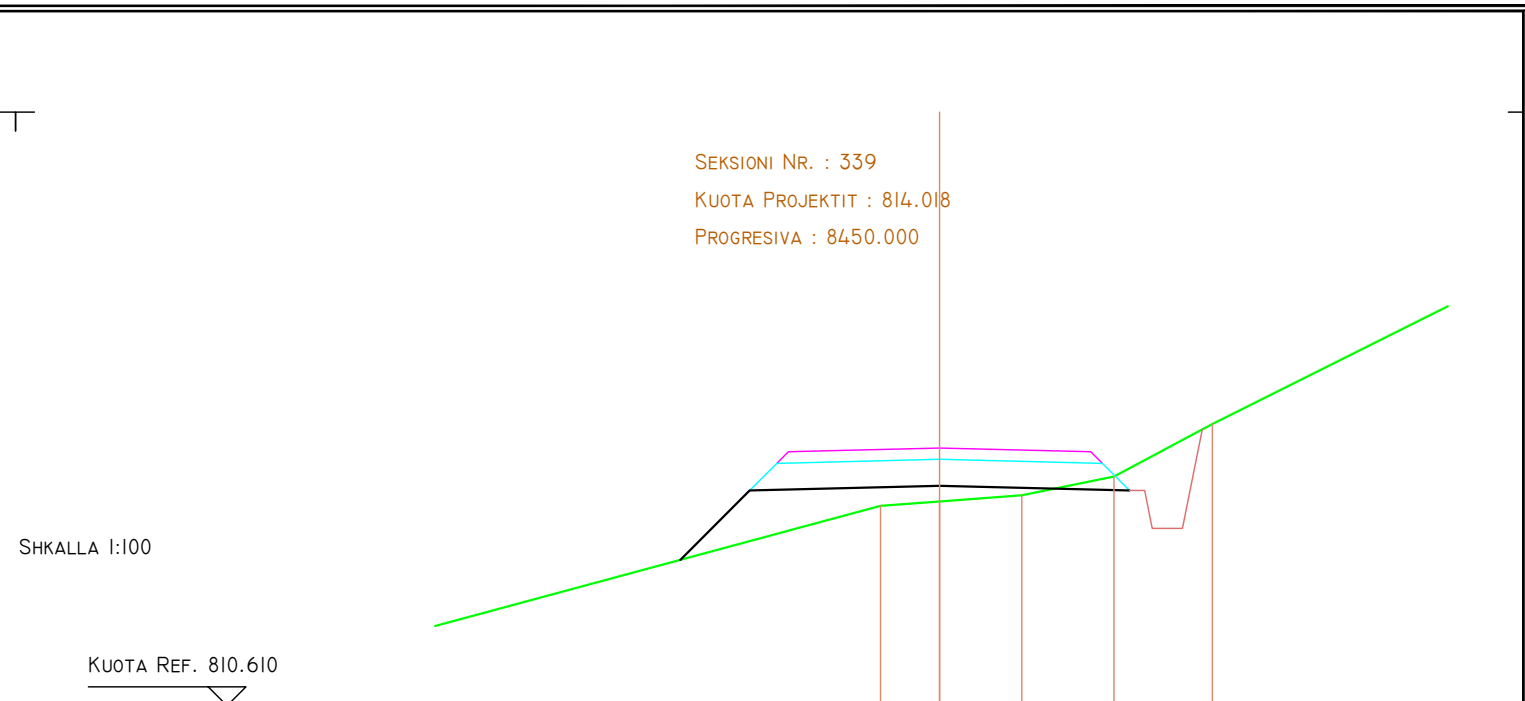

| | | | | | | |
|---------------------------|------------------|--------|--------|--------|--------|-----|
| KUOTA E TOKES | 813.25 | 813.31 | 813.39 | 813.64 | 814.34 | |
| DIST. PJESORE E TOKES | 7.0 | 0.8 | 1.1 | 1.2 | 1.3 | 4.6 |
| KUOTA E PROJEKTIT | 812.54 813.46 | 813.52 | 813.46 | | | |
| DIST. PJESORE E PROJEKTIT | 0.9 | 2.5 | 2.5 | | | |

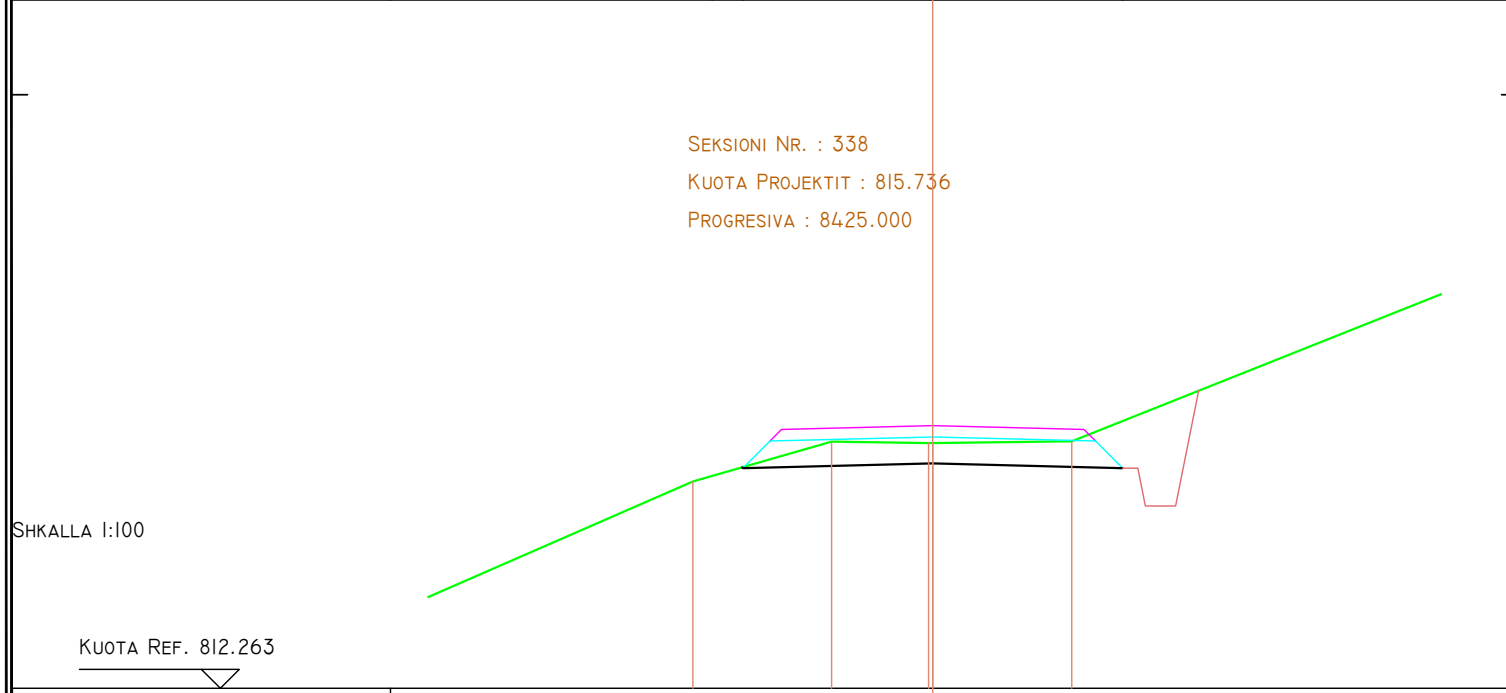

| | | | | |
|---------------------------|------------------|--------|------------------|--------|
| KUOTA E TOKES | 815.00 | 815.52 | 815.50 815.50 | 815.53 |
| DIST. PJESORE E TOKES | 6.3 | 1.8 | 1.3 | 1.8 |
| KUOTA E PROJEKTIT | 815.18 815.17 | 815.24 | 815.17 | |
| DIST. PJESORE E PROJEKTIT | | 2.5 | 2.5 | |

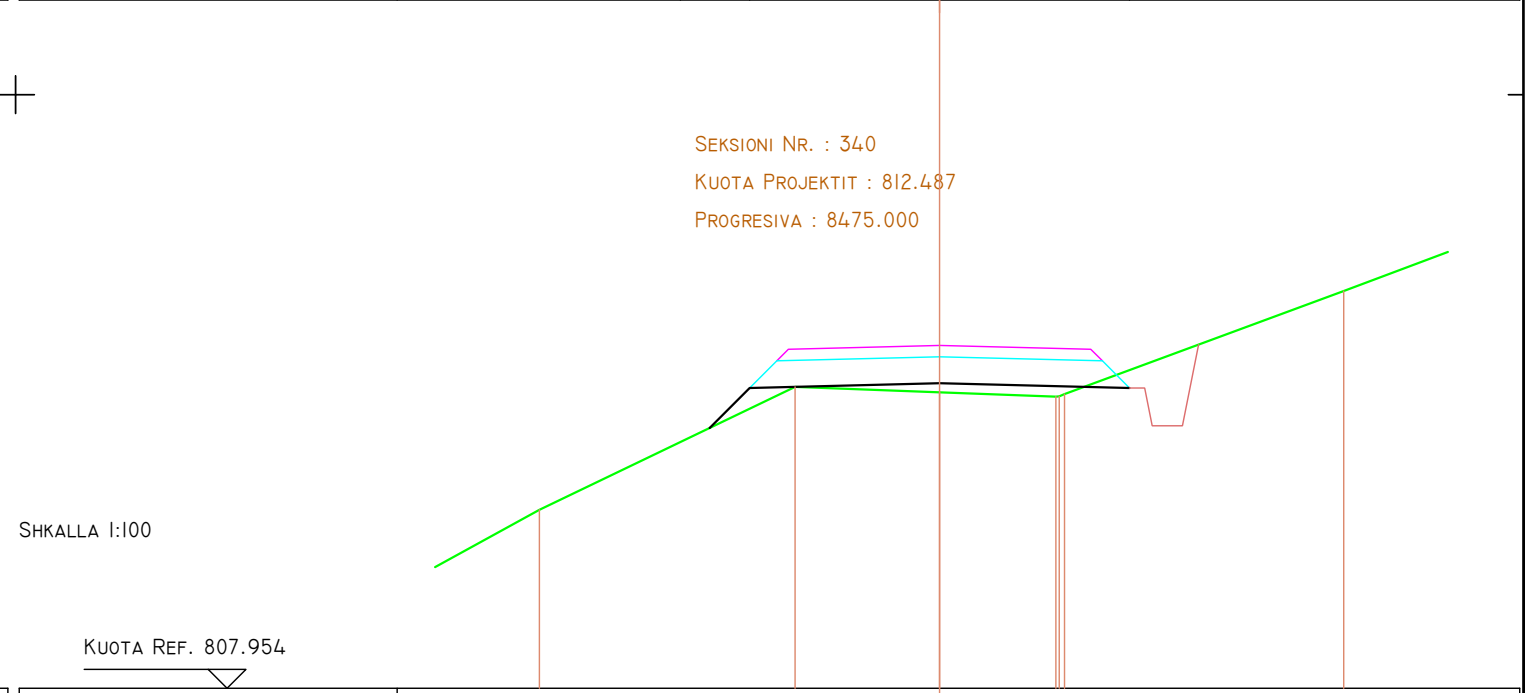

| | | | | | |
|---------------------------|------------------|--------|--------|----------------------------|--------|
| KUOTA E TOKES | 810.31 | 811.94 | 811.87 | 811.81 811.81 811.84 | 813.21 |
| DIST. PJESORE E TOKES | 3.4 | 1.9 | | | |
| KUOTA E PROJEKTIT | 811.40 811.92 | | | | |
| DIST. PJESORE E PROJEKTIT | 0.5 | 2.5 | | | |

BASHKIA LIBOHOVE

OBJEKTI:
 RIPARIMIN DHE ASFALTIM I RRUGËS
 AUTOMOBILIS TIKE FUSHA E ÇAJUPIT – TOPOVË,
 PJESË E UNAZËS SË ZAGORISË L= 8971 ML.

EMERTIMI I FLETES:
 PROFIL TERTHOR

HARTOI: SEKTORI SHERBIMIT URBAN
 ARK. NELSON SEJDO

Data:
 06/2024

SHK
 1:1000

Nr. fleta
 85

SEKSIONI NR. : 341
 KUOTA PROJEKTIT : 811.498
 PROGRESIVA : 8500.000

SHKALLA 1:100

KUOTA REF. 807.756

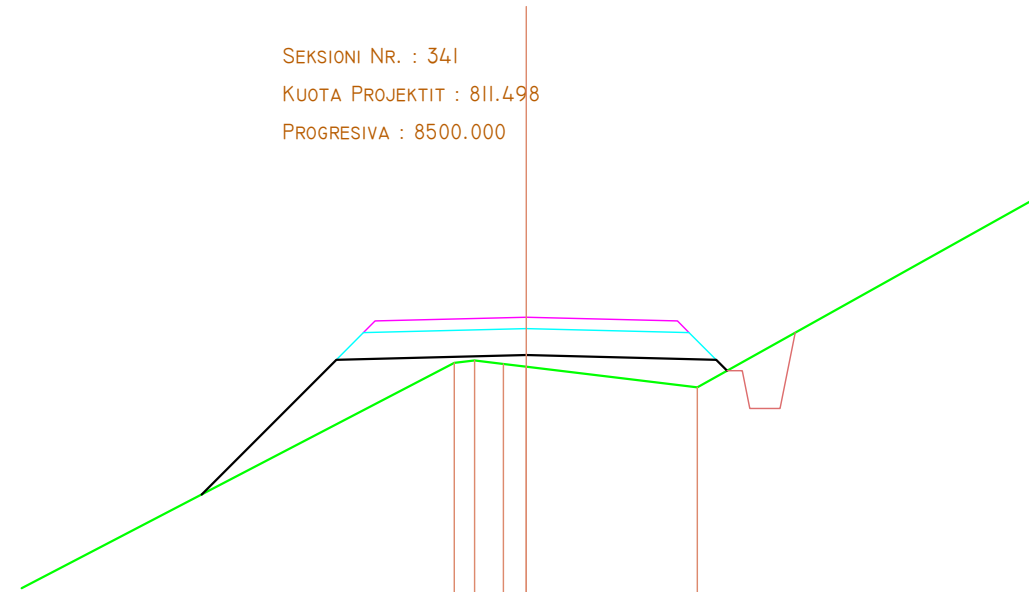

| | | | | | | |
|---------------------------|--------|--------|--------|--------|--------|--------|
| KUOTA E TOKES | | 800.89 | 800.93 | 800.88 | 800.84 | 800.57 |
| DIST. PJESORE E TOKES | | 0.3 | 0.4 | 0.3 | 2.3 | |
| KUOTA E PROJEKTIT | 809.15 | 810.94 | 811.00 | 810.94 | 810.79 | |
| DIST. PJESORE E PROJEKTIT | 1.8 | 2.5 | 2.5 | | | |

SEKSIONI NR. : 343
 KUOTA PROJEKTIT : 809.577
 PROGRESIVA : 8550.000

SHKALLA 1:100

KUOTA REF. 807.342

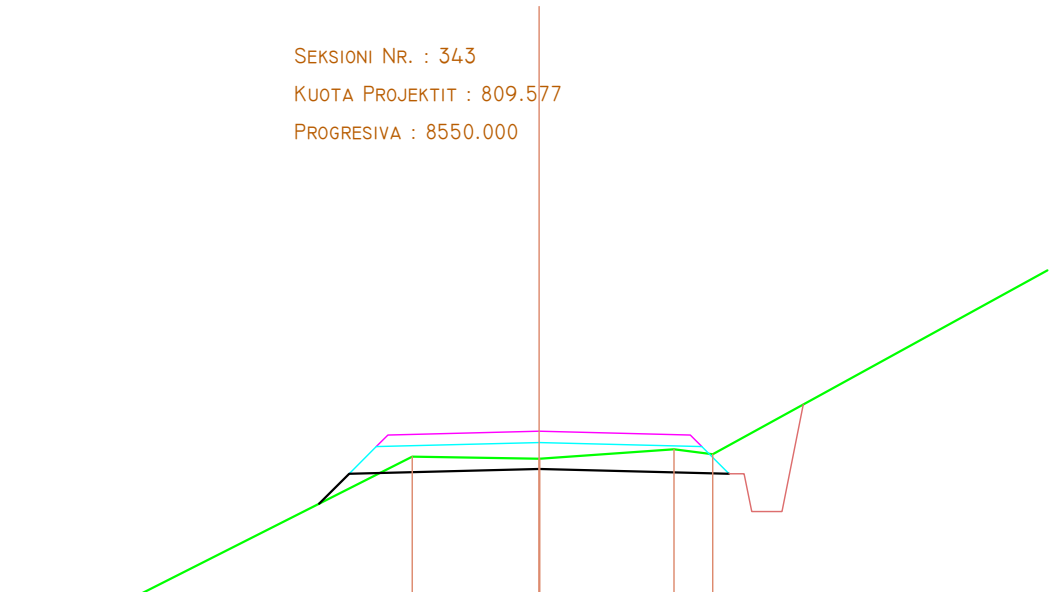

| | | | | | | |
|---------------------------|--------|--------|--------|--------|--------|--------|
| KUOTA E TOKES | | 809.24 | 809.21 | 809.21 | 809.34 | 809.27 |
| DIST. PJESORE E TOKES | 7.0 | | 1.7 | 1.8 | 0.5 | 4.7 |
| KUOTA E PROJEKTIT | 808.62 | 809.10 | 809.08 | 809.08 | 809.01 | |
| DIST. PJESORE E PROJEKTIT | 0.4 | 2.5 | 2.5 | | | |

SEKSIONI NR. : 342
 KUOTA PROJEKTIT : 810.538
 PROGRESIVA : 8525.000

SHKALLA 1:100

KUOTA REF. 807.185

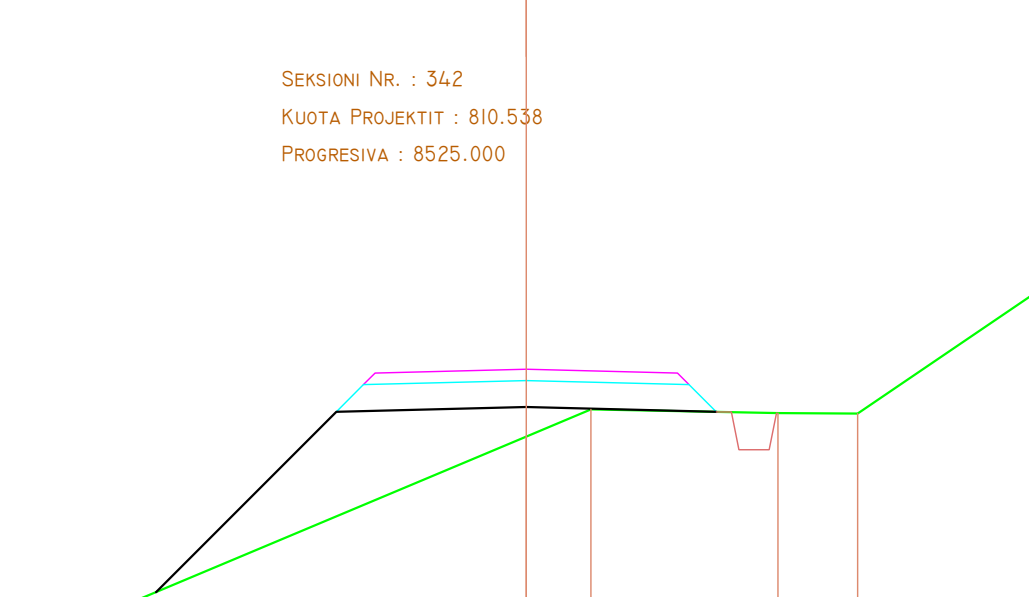

| | | | | | |
|---------------------------|--------|--------|--------|--------|--------|
| KUOTA E TOKES | | 809.65 | 810.01 | 809.96 | 809.95 |
| DIST. PJESORE E TOKES | | 0.9 | 2.5 | 1.1 | |
| KUOTA E PROJEKTIT | 807.59 | 809.97 | 810.04 | 809.97 | 809.97 |
| DIST. PJESORE E PROJEKTIT | 2.4 | 2.5 | 2.5 | | |

SEKSIONI NR. : 344
 KUOTA PROJEKTIT : 808.617
 PROGRESIVA : 8575.000

SHKALLA 1:100

KUOTA REF. 806.773

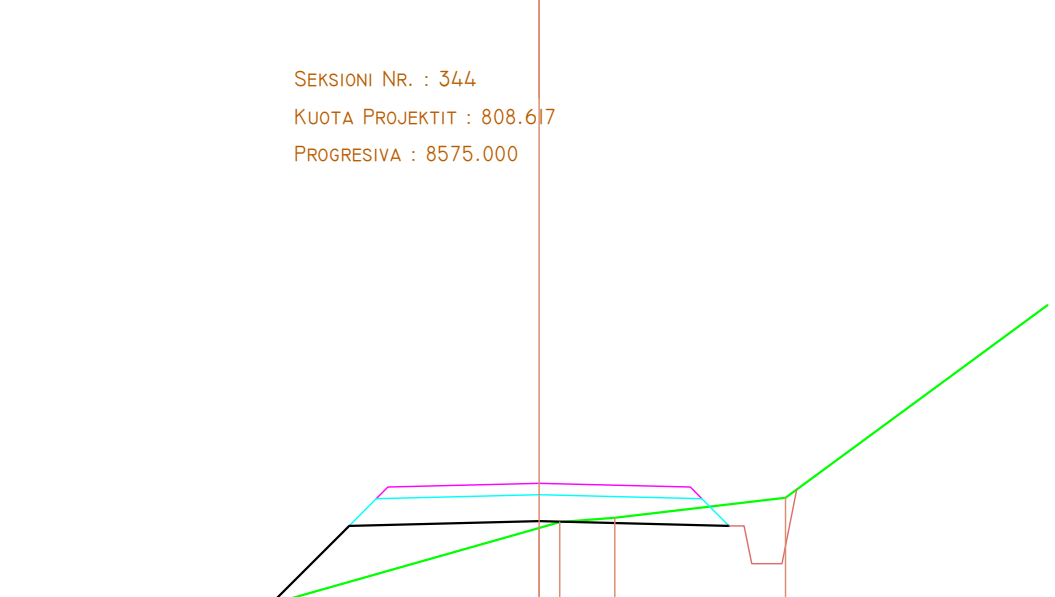

| | | | | | | |
|---------------------------|--------|--------|--------|--------|--------|--------|
| KUOTA E TOKES | | 806.55 | 808.03 | 808.10 | 808.16 | 808.43 |
| DIST. PJESORE E TOKES | | 5.2 | | | | |
| KUOTA E PROJEKTIT | 807.02 | 808.05 | | | | |
| DIST. PJESORE E PROJEKTIT | 1.0 | 2.5 | | | | |



BASHKIA LIBOHOVE

OBJEKTI:
 RIPARIMIN DHE ASFALTIM I RRUGËS
 AUTOMOBILIS TIKE FUSHA E ÇAJUPIT – TOPOVË,
 PJESË E UNAZËS SË ZAGORISË L= 8971 ML.

Data:
 06/2024

EMERTIMI I FLETES:
 PROFIL TERTHOR

SHK
 1:1000

HARTOI: SEKTORI SHERBIMIT URBAN
 ARK. NELSON SEJDO

Nr. fleta
 86

SEKSIONI NR. : 345
 KUOTA PROJEKTIT : 807.656
 PROGRESIVA : 8600.000

SEKSIONI NR. : 347
 KUOTA PROJEKTIT : 806.376
 PROGRESIVA : 8650.000

SHKALLA 1:100

SHKALLA 1:100

KUOTA REF. 804.177

KUOTA REF. 804.541

| | | | | | |
|---------------------------|-----|------------------|--------|------------------|--------|
| KUOTA E TOKES | | 806.58 | 807.28 | 807.37 807.37 | 807.52 |
| DIST. PJESORE E TOKES | 6.3 | 2.3 | 0.8 | 2.3 | |
| KUOTA E PROJEKTIT | | 806.63 807.09 | 807.16 | 807.09 | |
| DIST. PJESORE E PROJEKTIT | | 0.5 | 2.5 | 2.5 | |

| | | | | | | | |
|---------------------------|-----|--------|--------|--------|--------|--------|--------|
| KUOTA E TOKES | | 804.40 | 805.77 | 806.10 | 806.44 | 807.14 | 808.85 |
| DIST. PJESORE E TOKES | 3.3 | 3.8 | 0.7 | 0.7 | 2.5 | 2.3 | |
| KUOTA E PROJEKTIT | | 804.70 | 805.81 | 805.88 | 805.81 | | |
| DIST. PJESORE E PROJEKTIT | | 1.1 | 2.5 | 2.5 | | | |

SEKSIONI NR. : 346
 KUOTA PROJEKTIT : 806.784
 PROGRESIVA : 8625.000

SEKSIONI NR. : 348
 KUOTA PROJEKTIT : 805.806
 PROGRESIVA : 8675.000

SHKALLA 1:100

SHKALLA 1:100

KUOTA REF. 803.444

KUOTA REF. 805.709

| | | | | |
|---------------------------|-----|------------------|--------|----------------------------|
| KUOTA E TOKES | | 806.20 | 806.27 | 806.80 806.82 806.84 |
| DIST. PJESORE E TOKES | 8.7 | 0.3 | 2.2 | |
| KUOTA E PROJEKTIT | | 805.36 806.22 | 806.28 | 806.22 |
| DIST. PJESORE E PROJEKTIT | | 0.9 | 2.5 | 2.5 |

| | | | | |
|---------------------------|-----|------------------|--------|--|
| KUOTA E TOKES | | 804.34 | 805.52 | 805.44 805.45 805.38 805.37 805.75 |
| DIST. PJESORE E TOKES | 2.7 | 1.9 | | |
| KUOTA E PROJEKTIT | | 805.23 805.24 | | |
| DIST. PJESORE E PROJEKTIT | | 2.5 | | |

| | |
|---|------------------|
| BASHKIA LIBOHOVE | |
| OBJEKTI: RIPARIMIN DHE ASFALTIM I RRUGËS AUTOMOBILIS TIKE FUSHA E ÇAJUPIT – TOPOVË, PJESË E UNAZËS SË ZAGORISË L= 8971 ML. | Data: 06/2024 |
| EMERTIMI I FLETES: PROFIL TERTHOR | SHK 1:1000 |
| HARTOI: SEKTORI SHERBIMIT URBAN ARK. NELSON SEJDO | Nr. fleta 87 |

SEKSIONI NR. : 349
 KUOTA PROJEKTIT : 804.635
 PROGRESIVA : 8700.000

SEKSIONI NR. : 351
 KUOTA PROJEKTIT : 801.879
 PROGRESIVA : 8750.000

SHKALLA 1:100

SHKALLA 1:100

KUOTA REF. 803.511

KUOTA REF. 800.152

| | | | | | | | | | |
|---------------------------|--------|--------|--------|--------|--------|--------|--------|--------|-----|
| KUOTA E TOKES | 802.15 | | | 803.95 | 803.94 | 803.94 | 804.05 | 804.32 | |
| DIST. PJESORE E TOKES | | 5.2 | | 0.6 | 0.7 | 1.7 | 1.0 | | 5.6 |
| KUOTA E PROJEKTIT | | 802.89 | 804.07 | | 804.13 | | 804.07 | 804.07 | |
| DIST. PJESORE E PROJEKTIT | | 1.2 | 2.5 | | 2.5 | | | | |

| | | | | | | | | |
|---------------------------|--|-----|--------|--------|--------|--------|--------|--------|
| KUOTA E TOKES | | | 800.80 | 801.26 | 801.54 | 801.57 | 801.90 | |
| DIST. PJESORE E TOKES | | 5.6 | | 2.1 | 1.2 | 0.3 | 0.6 | |
| KUOTA E PROJEKTIT | | | 800.62 | 801.32 | | 801.38 | | 801.32 |
| DIST. PJESORE E PROJEKTIT | | | 0.7 | 2.5 | | 2.5 | | |

SEKSIONI NR. : 350
 KUOTA PROJEKTIT : 803.257
 PROGRESIVA : 8725.000

SEKSIONI NR. : 352
 KUOTA PROJEKTIT : 800.482
 PROGRESIVA : 8775.000

SHKALLA 1:100

SHKALLA 1:100

KUOTA REF. 802.391

KUOTA REF. 799.269

| | | | | | | | | | |
|---------------------------|--------|--------|--------|--------|--------|--------|--------|--------|--|
| KUOTA E TOKES | 800.93 | | | 802.30 | 802.64 | 802.72 | 802.80 | 803.48 | |
| DIST. PJESORE E TOKES | | 4.9 | | 1.8 | 0.4 | 0.8 | 1.2 | | |
| KUOTA E PROJEKTIT | | 801.87 | 802.69 | | 802.76 | | 802.69 | | |
| DIST. PJESORE E PROJEKTIT | | 0.8 | 2.5 | | 2.5 | | | | |

| | | | | | | | | |
|---------------------------|--|--|--------|--------|--------|--------|--------|--|
| KUOTA E TOKES | | | 800.00 | 800.10 | 800.08 | 800.02 | 802.90 | |
| DIST. PJESORE E TOKES | | | 1.2 | 0 | | | | |
| KUOTA E PROJEKTIT | | | 799.55 | 799.92 | | | | |
| DIST. PJESORE E PROJEKTIT | | | 0.4 | 2.5 | | | | |



BASHKIA LIBOHOVE
 OBJEKTI:
 RIPARIMIN DHE ASFALTIM I RRUGËS
 AUTOMOBILIS TIKE FUSHA E ÇAJUPIT – TOPOVË,
 PJESË E UNAZËS SË ZAGORISË L= 8971 ML.

Data:
06/2024

EMERTIMI I FLETES:
 PROFIL TERTHOR

SHK
1:1000

HARTOI: SEKTORI SHERBIMIT URBAN
 ARK. NELSON SEJDO

Nr. fleta
88

SEKSIONI NR. : 353
 KUOTA PROJEKTIT : 798.081
 PROGRESIVA : 8800.000

SEKSIONI NR. : 355
 KUOTA PROJEKTIT : 791.759
 PROGRESIVA : 8850.000

SHKALLA 1:100

SHKALLA 1:100

KUOTA REF. 795.928

KUOTA REF. 788.693

| | | | | | | | | | |
|---------------------------|--------|--------|--------|--------|--------|--------|-----|--------|--------|
| KUOTA E TOKES | 794.86 | | | 797.74 | 797.81 | 797.88 | | 797.73 | 799.49 |
| DIST. PJESORE E TOKES | | 6.1 | | 0.6 | 0.6 | | 2.3 | | 3.3 |
| KUOTA E PROJEKTIT | | 796.23 | 797.52 | | 797.56 | | | 797.52 | |
| DIST. PJESORE E PROJEKTIT | | 1.3 | 2.5 | | 2.5 | | | | |

| | | | | | | | | | |
|---------------------------|--------|--------|--------|--------|--------|--------|-----|--------|--------|
| KUOTA E TOKES | 789.76 | | | 790.64 | 790.59 | 790.61 | | 790.92 | 791.04 |
| DIST. PJESORE E TOKES | | 4.9 | | 0.9 | 0.2 | | 2.7 | | 3.5 |
| KUOTA E PROJEKTIT | | 790.22 | 791.20 | | 791.26 | | | 791.20 | 790.92 |
| DIST. PJESORE E PROJEKTIT | | 1.0 | 2.5 | | 2.5 | | 0.3 | | |

SEKSIONI NR. : 354
 KUOTA PROJEKTIT : 794.884
 PROGRESIVA : 8825.000

SEKSIONI NR. : 356
 KUOTA PROJEKTIT : 790.153
 PROGRESIVA : 8875.000

SHKALLA 1:100

SHKALLA 1:100

KUOTA REF. 792.822

KUOTA REF. 789.538

| | | | | | | | | | |
|---------------------------|--------|--------|--------|--------|--------|--|--------|--------|--------|
| KUOTA E TOKES | 793.90 | | | 794.79 | 794.74 | | 794.54 | | 794.34 |
| DIST. PJESORE E TOKES | | 3.0 | | 0.4 | 1.9 | | 1.9 | | |
| KUOTA E PROJEKTIT | | 794.65 | 794.32 | | 794.36 | | | 794.32 | |
| DIST. PJESORE E PROJEKTIT | | 0.3 | 2.5 | | 2.5 | | | | |

| | | | | | | | | | |
|---------------------------|--------|--------|--------|--------|--------|--------|--|--------|--|
| KUOTA E TOKES | 789.42 | | | 789.54 | 789.56 | 789.51 | | 790.45 | |
| DIST. PJESORE E TOKES | | 2.0 | | | | | | | |
| KUOTA E PROJEKTIT | | 789.30 | 789.59 | | | | | | |
| DIST. PJESORE E PROJEKTIT | | 0.3 | 2.5 | | | | | | |



BASHKIA LIBOHOVE
 OBJEKTI:
 RIPARIMIN DHE ASFALTIM I RRUGËS
 AUTOMOBILIS TIKE FUSHA E ÇAJUPIT – TOPOVË,
 PJESË E UNAZËS SË ZAGORISË L= 8971 ML.

Data:
06/2024

EMERTIMI I FLETES:
 PROFIL TERTHOR

SHK
1:1000

HARTOI: SEKTORI SHERBIMIT URBAN
 ARK. NELSON SEJDO

Nr. fleta
89

SEKSIONI NR. : 357
 KUOTA PROJEKTIT : 789.804
 PROGRESIVA : 8900.000

SEKSIONI NR. : 359
 KUOTA PROJEKTIT : 789.131
 PROGRESIVA : 8950.000

SHKALLA 1:100

SHKALLA 1:100

KUOTA REF. 788.531

KUOTA REF. 786.271

| | | | | | |
|---------------------------|------------------|--------|------------------|--------|--|
| KUOTA E TOKES | 788.69 | 789.42 | 789.53 789.51 | 789.41 | |
| DIST. PJESORE E TOKES | 3.1 | 1.4 | 0.2 1.1 | 6.0 | |
| KUOTA E PROJEKTIT | 789.20 789.24 | 789.30 | 789.24 | | |
| DIST. PJESORE E PROJEKTIT | | 2.5 | 2.5 | | |

| | | | | | |
|---------------------------|------------------|--------|--------|----------------------------|--------|
| KUOTA E TOKES | 788.18 | 788.67 | 788.70 | 788.73 788.73 788.73 | 789.31 |
| DIST. PJESORE E TOKES | 1.9 | 2.1 | 1.4 | 0.2 0.2 | 1.5 |
| KUOTA E PROJEKTIT | 788.55 788.57 | 788.63 | 788.57 | | |
| DIST. PJESORE E PROJEKTIT | | 2.5 | 2.5 | | |

SEKSIONI NR. : 358
 KUOTA PROJEKTIT : 789.468
 PROGRESIVA : 8925.000

SEKSIONI NR. : 360
 KUOTA PROJEKTIT : 788.842
 PROGRESIVA : 8971.500

SHKALLA 1:100

SHKALLA 1:100

KUOTA REF. 787.660

KUOTA REF. 786.032

| | | | | |
|---------------------------|------------------|--------|------------------|--------|
| KUOTA E TOKES | | 789.16 | 789.23 789.23 | 789.24 |
| DIST. PJESORE E TOKES | 6.9 | 0.6 | 0.2 2.1 | |
| KUOTA E PROJEKTIT | 788.73 788.90 | 788.97 | 788.90 | |
| DIST. PJESORE E PROJEKTIT | | 2.5 | 2.5 | |

| | | | | | | | | |
|---------------------------|------------------|------------------|------------------|--------|--------|--------|--------|--------|
| KUOTA E TOKES | 787.97 | 787.97 787.98 | 788.01 788.09 | 788.22 | 788.56 | 788.68 | 788.87 | 788.88 |
| DIST. PJESORE E TOKES | 0.7 | 0.7 | 0.3 1.6 | 2.0 | 0.7 | 0.1 | 0.0 | 0.1 |
| KUOTA E PROJEKTIT | 788.17 788.28 | 788.28 | | | | | | |
| DIST. PJESORE E PROJEKTIT | | 2.5 | | | | | | |



BASHKIA LIBOHOVE

OBJEKTI:
 RIPARIMIN DHE ASFALTIM I RRUGËS
 AUTOMOBILIS TIKE FUSHA E ÇAJUPIT – TOPOVË,
 PJESË E UNAZËS SË ZAGORISË L= 8971 ML.

Data:
 06/2024

EMERTIMI I FLETES:
 PROFIL TERTHOR

SHK
 1:1000

HARTOI: SEKTORI SHERBIMIT URBAN
 ARK. NELSON SEJDO

Nr. fleta
 90