

PROJEKTI ELEKTRIK I NDRIÇIMIT I RRUGËS

"NDËRTIMI I RRUGËS SUPERSTRADË - HIDROVOR (TALE)"



Klienti:

BASHKIA LEZHË

Titulli i Projektit:

**NDËRTIMI I RRUGËS
SUPERSTRADË -
HIDROVOR (TALE)**

Faza:

PROJEKT ZBATIMI

Projektuesi:



"STATENG" SH.P.K N. 6965/3

Inxh.Ndërt.	ALTIN SERANAJ	K. 2455/2
Inxh.Ndërt.	ARSELA VOGLI	
Inxh.Elek.	ARJAN SHYTI	E. 1126/3
Inxh.Gjeodet	ERION LAMI	T. 1111/1

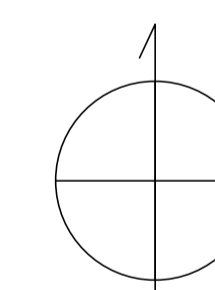

Kapitulli:

PROJEKTI ELEKTRIK

Titulli:

KAPUKU I PROJEKTIT ELEKTRIK

Shkalla:

1:500

Nr :

E-00

Data:

2022

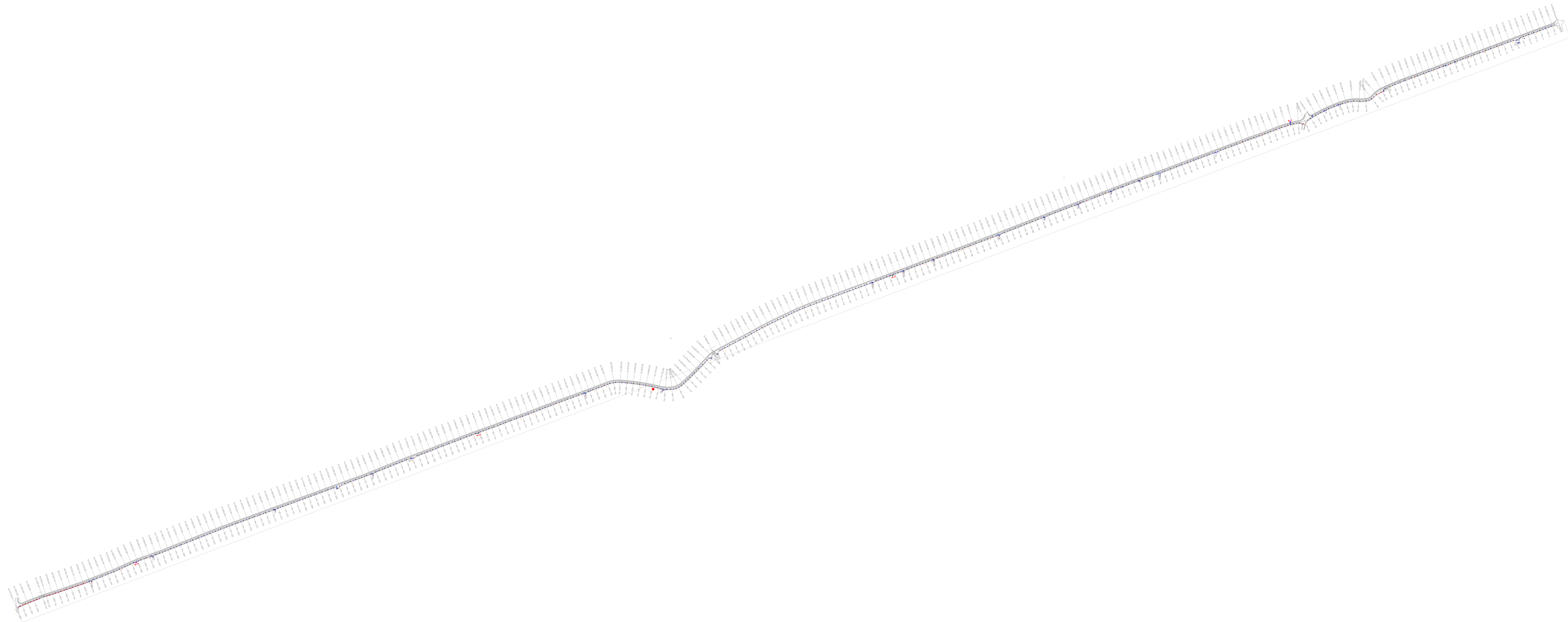

LEGJENDA

	POSITJE E KAZEMIT NE BASHKISEN E BASHKISEN
	POSITJE E KAZEMIT NE BASHKISEN E BASHKISEN
	POSITJE E KAZEMIT NE BASHKISEN E BASHKISEN
	POSITJE E KAZEMIT NE BASHKISEN E BASHKISEN
	POSITJE E KAZEMIT NE BASHKISEN E BASHKISEN
	POSITJE E KAZEMIT NE BASHKISEN E BASHKISEN
	POSITJE E KAZEMIT NE BASHKISEN E BASHKISEN
	POSITJE E KAZEMIT NE BASHKISEN E BASHKISEN



Klienti:
BASHKIA LEZHË

Titulli i Projektit:
**NDËRTIMI I RRUGËS
SUPERSTRADË -
HIDROVOR (TALE)**

Faza:
PROJEKT ZBATIMI

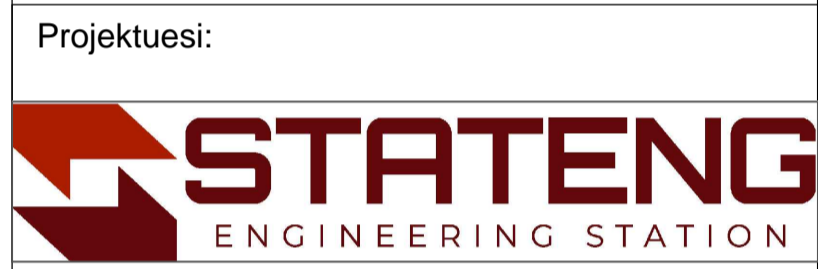

STATENG SH.P.K		N. 6965/3
Inxh.Ndërt.	ALTIN SERANAJ	K. 2455/2
Inxh.Ndërt.	ARSELA VOGLI	
Inxh.Elek.	ARJAN SHYTI	E. 1126/3
Inxh.Gjeodet	ERION LAMI	T. 1111/1

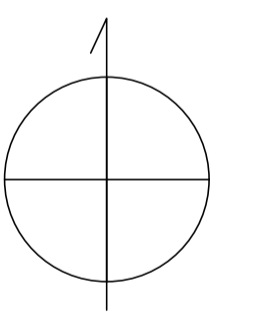

Kapitulli:
PROJEKTI ELEKTRIK

Titulli:
**PLANI I PERGJITHSEM I INSTALIMEVE
TE NDRICIMIT RRUGOR**

Shkalla:
1:5000

Nr :
E-01

Data:
2022



Klienti:

BASHKIA LEZHË

Titulli i Projektit:

**NDËRTIMI I RRUGËS
SUPERSTRADË -
HIDROVOR (TALE)**

Faza:

PROJEKT ZBATIMI

Projektuesi:

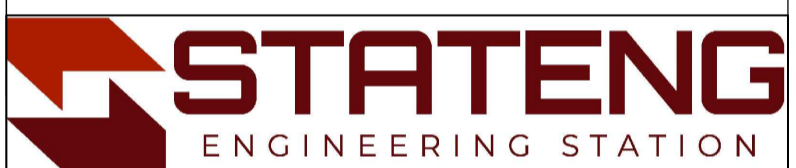

"STATENG" SH.P.K N. 6965/3

Inxh.Ndërt. ALTIN SERANAJ K. 2455/2

Inxh.Ndërt. ARSELA VOGLI

Inxh.Elek. ARJAN SHYTI E. 1126/3

Inxh.Gjeodet ERION LAMI T. 1111/1

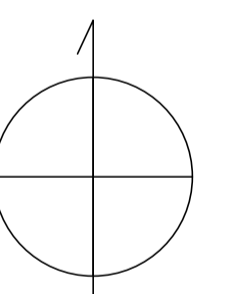

Kapitulli:

PROJEKTI ELEKTRIK

Titulli:

**PLANI I INSTALIMEVE TE NDRICIMIT
RRUGOR PK 1-16**

Shkalla:

1:500

Nr :

E-02

Data:

2022

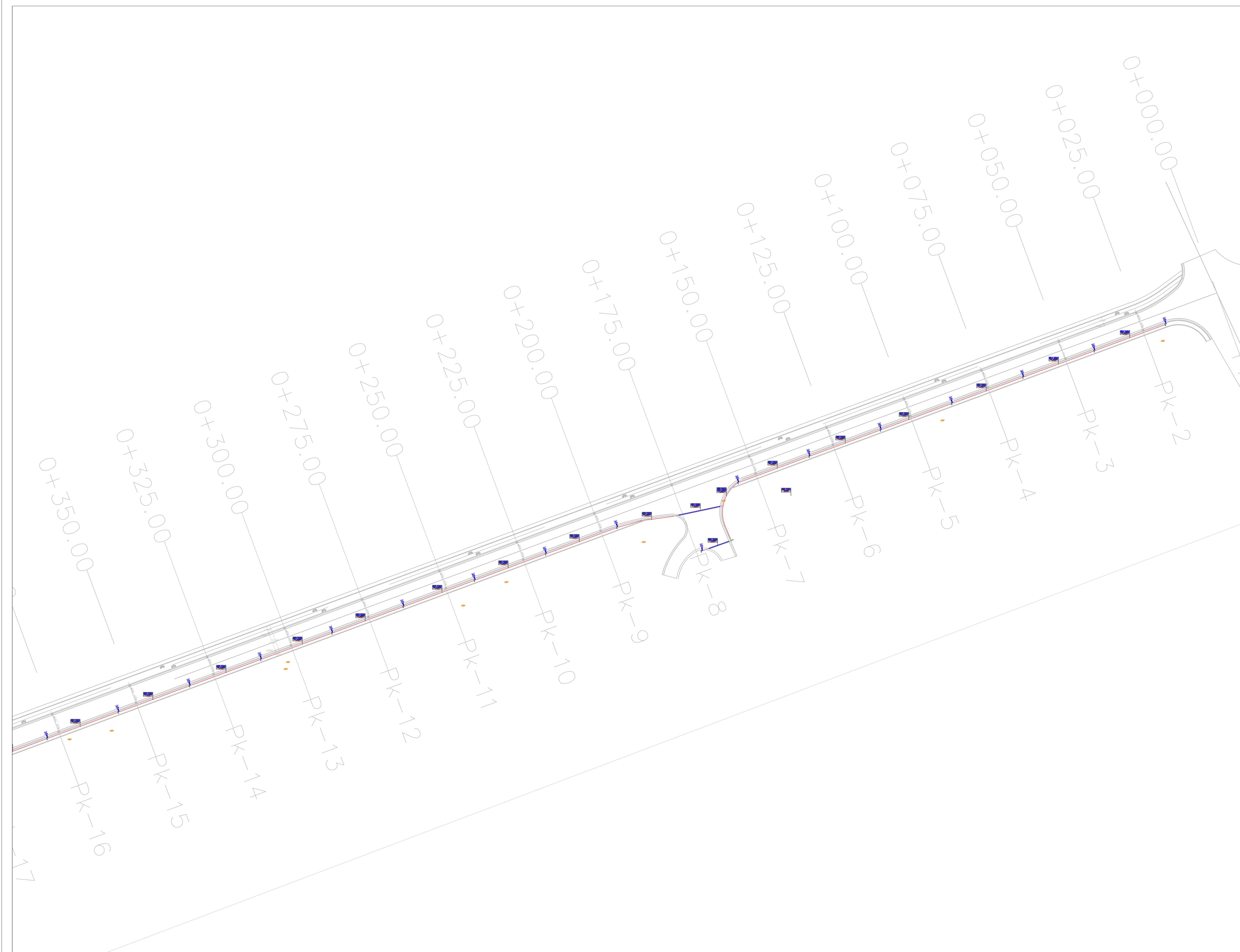



Klienti:

BASHKIA LEZHË

Titulli i Projektit:

**NDËRTIMI I RRUGËS
SUPERSTRADË -
HIDROVOR (TALE)**

Faza:

PROJEKT ZBATIMI

Projektuesi:

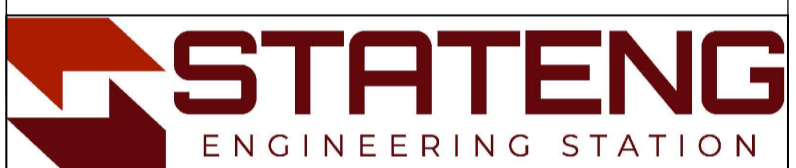

"STATENG" SH.P.K N. 6965/3

Inxh.Ndërt. ALTIN SERANAJ K. 2455/2

Inxh.Ndërt. ARSELA VOGLI

Inxh.Elek. ARJAN SHYTI E. 1126/3

Inxh.Gjeodet ERION LAMI T. 1111/1

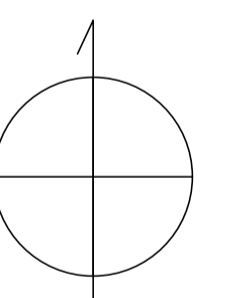

Kapitulli:

PROJEKTI ELEKTRIK

Titulli:

**PLANI I INSTALIMEVE TE NDRICIMIT
RRUGOR Pk 17-32**

Shkalla:

1:500

Nr :

E-03

Data:

2022

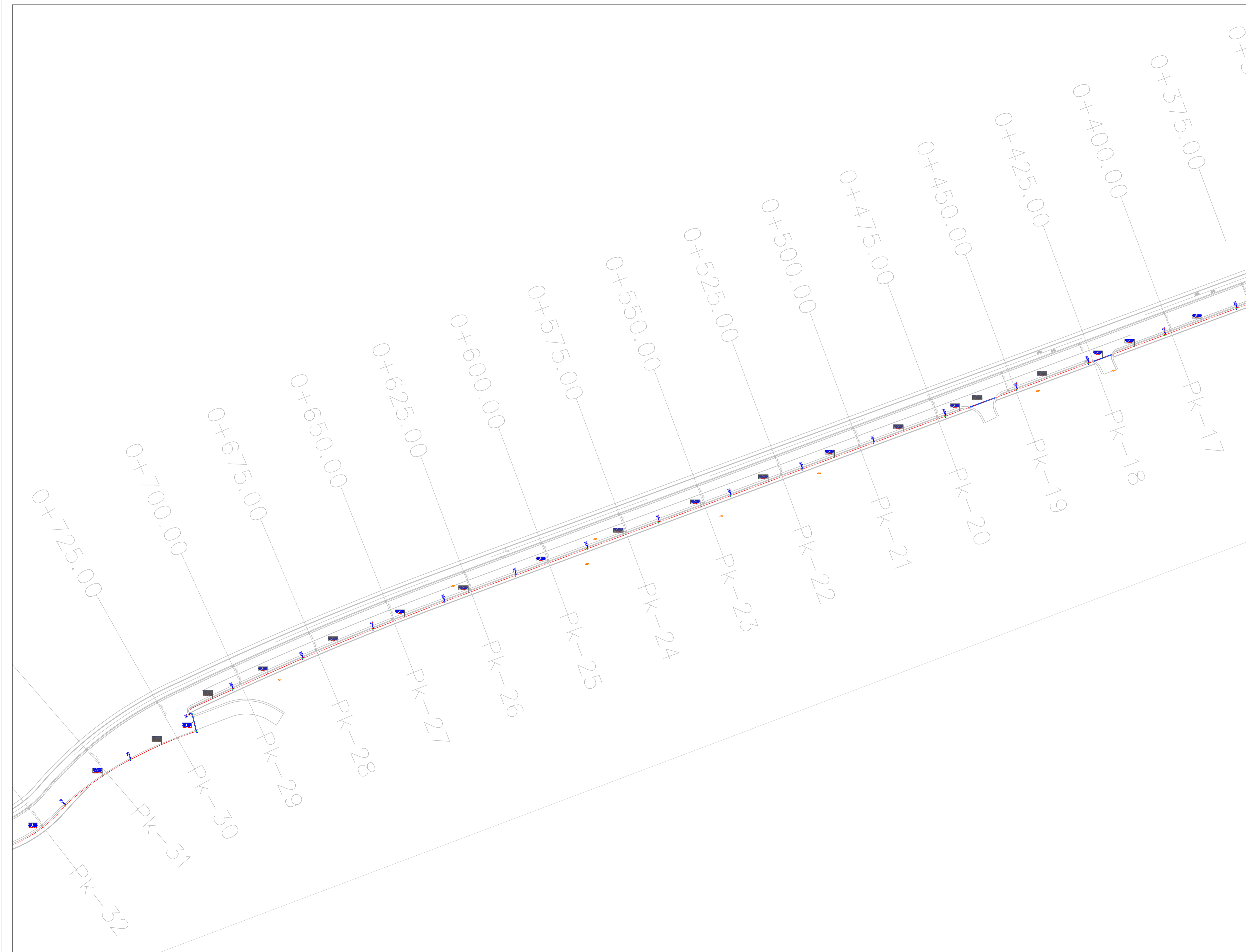



Klienti:

BASHKIA LEZHË

Titulli i Projektit:

**NDËRTIMI I RRUGËS
SUPERSTRADË -
HIDROVOR (TALE)**

Faza:

PROJEKT ZBATIMI

Projektuesi:



"STATENG" SH.P.K N. 6965/3

Inxh.Ndërt. ALTIN SERANAJ K. 2455/2

Inxh.Ndërt. ARSELA VOGLI

Inxh.Elek. ARJAN SHYTI E. 1126/3

Inxh.Gjeodet ERION LAMI T. 1111/1

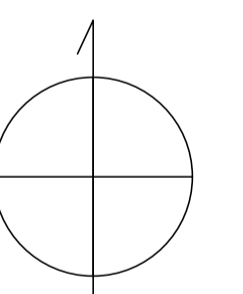

Kapitulli:

PROJEKTI ELEKTRIK

Titulli:

**PLANI I INSTALIMEVE TE NDRICIMIT
RRUGOR Pk 33-48**

Shkalla:

1:500

Nr.:

E-04

Data:

2022





Klienti:

BASHKIA LEZHË

Titulli i Projektit:

**NDËRTIMI I RRUGËS
SUPERSTRADË -
HIDROVOR (TALE)**

Faza:

PROJEKT ZBATIMI

Projektuesi:



"STATENG" SH.P.K N. 6965/3

Inxh.Ndërt. ALTIN SERANAJ K. 2455/2

Inxh.Ndërt. ARSELA VOGLI

Inxh.Elek. ARJAN SHYTI E. 1126/3

Inxh.Gjeodet ERION LAMI T. 1111/1

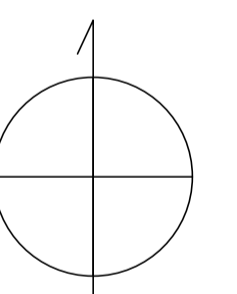

Kapitulli:

PROJEKTI ELEKTRIK

Titulli:

**PLANI I INSTALIMEVE TE NDRICIMIT
RRUGOR Pk 49-64**

Shkalla:

1:500

Nr.:

E-05

Data:

2022

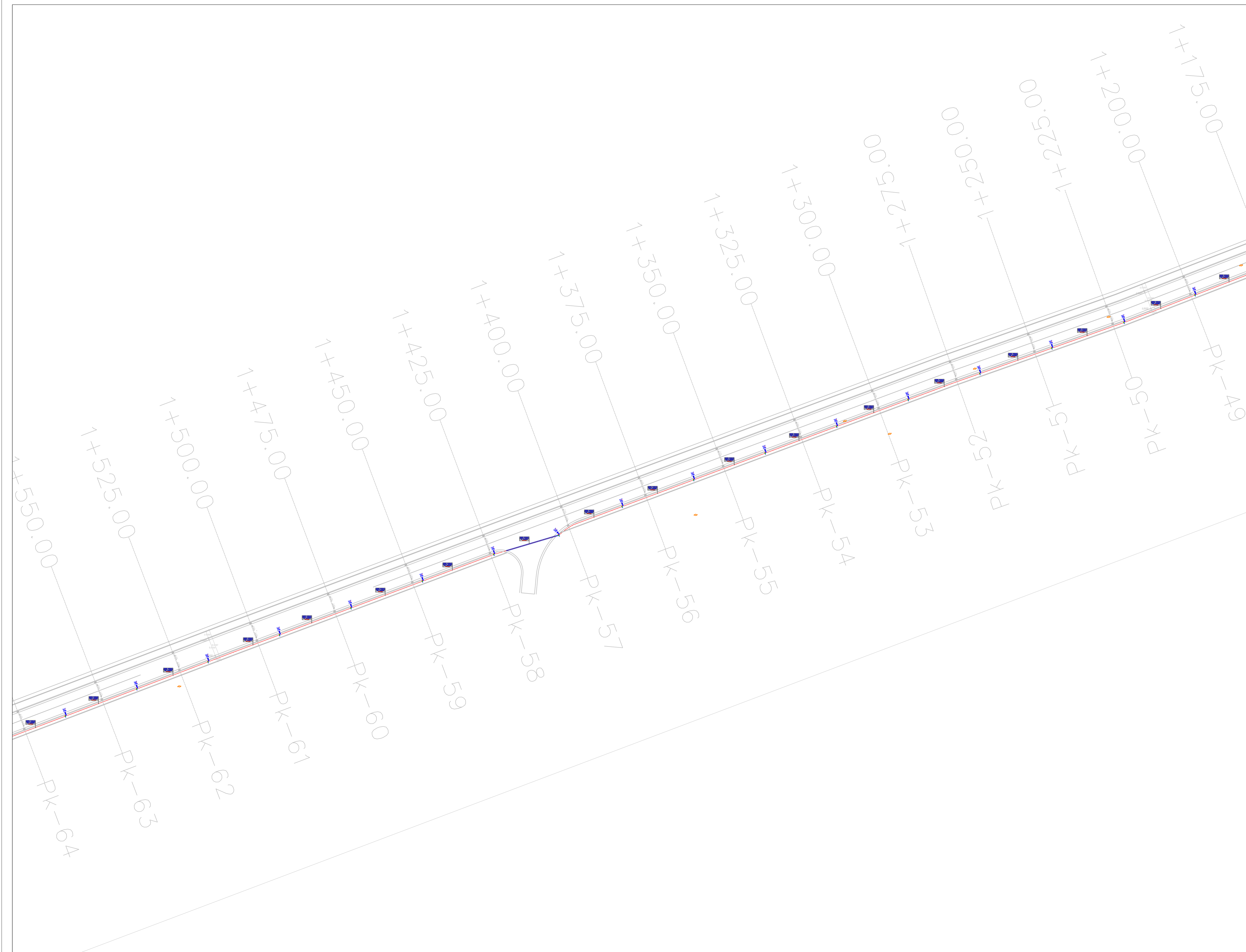



Klienti:

BASHKIA LEZHË

Titulli i Projektit:

**NDËRTIMI I RRUGËS
SUPERSTRADË -
HIDROVOR (TALE)**

Faza:

PROJEKT ZBATIMI

Projektuesi:

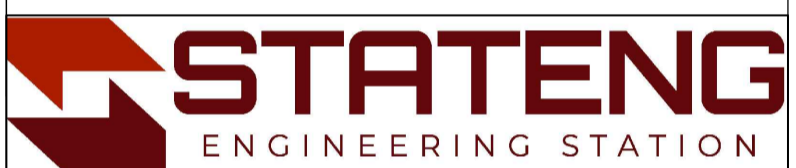

"STATENG" SH.P.K N. 6965/3

Inxh.Ndërt. ALTIN SERANAJ K. 2455/2

Inxh.Ndërt. ARSELA VOGLI

Inxh.Elek. ARJAN SHYTI E. 1126/3

Inxh.Gjeodet ERION LAMI T. 1111/1

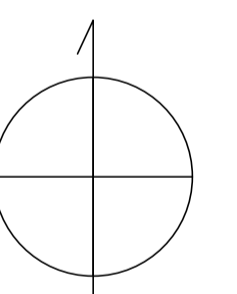

Kapitulli:

PROJEKTI ELEKTRIK

Titulli:

**PLANI I INSTALIMEVE TE NDRICIMIT
RRUGOR Pk 65-80**

Shkalla:

1:500

Nr :

E-06

Data:

2022

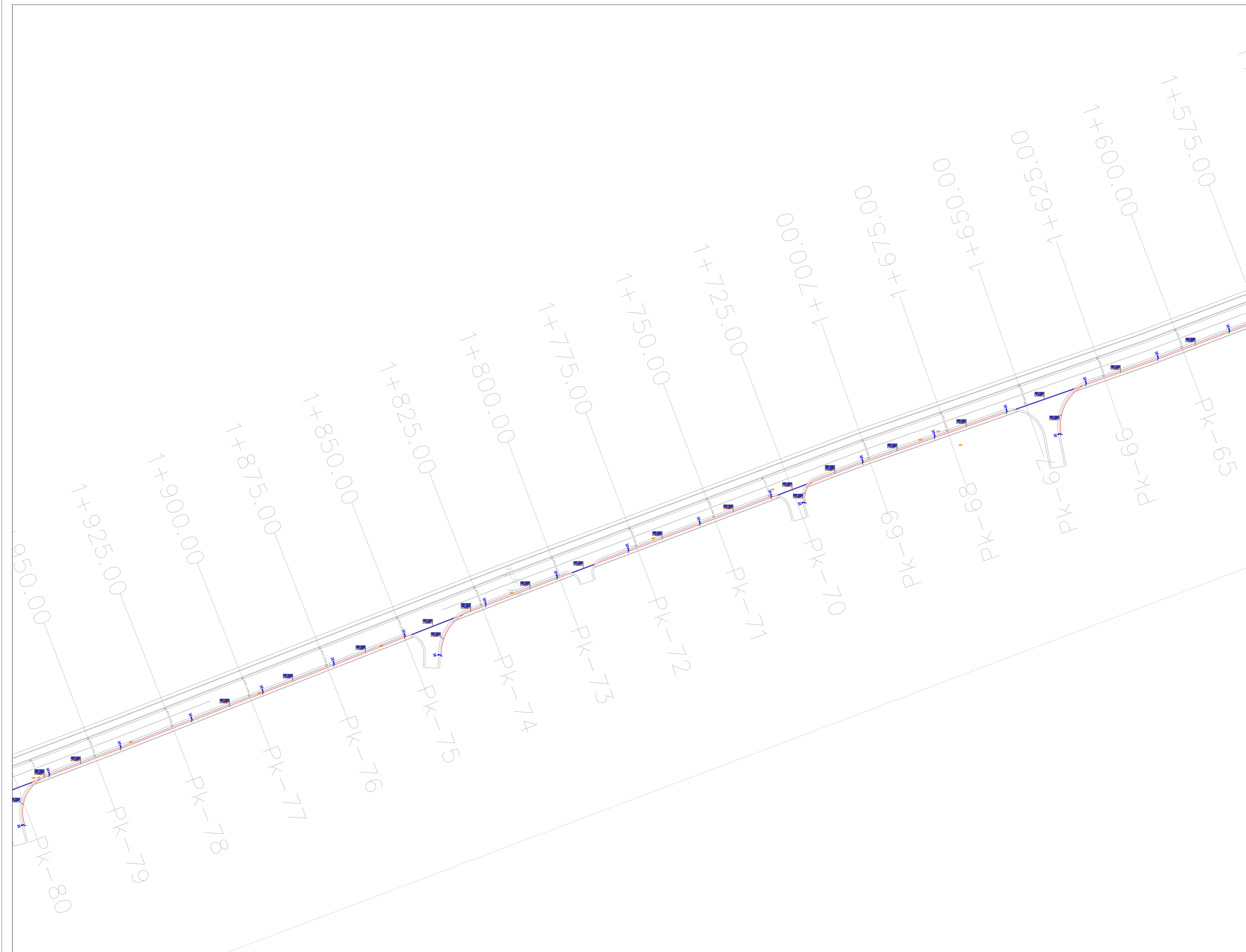



Klienti:

BASHKIA LEZHË

Titulli i Projektit:

**NDËRTIMI I RRUGËS
SUPERSTRADË -
HIDROVOR (TALE)**

Faza:

PROJEKT ZBATIMI

Projektuesi:



"STATENG" SH.P.K N. 6965/3

Inxh.Ndërt. ALTIN SERANAJ K. 2455/2

Inxh.Ndërt. ARSELA VOGLI

Inxh.Elek. ARJAN SHYTI E. 1126/3

Inxh.Gjeodet ERION LAMI T. 1111/1

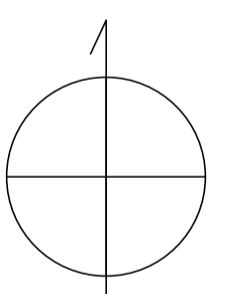

Kapitulli:

PROJEKTI ELEKTRIK

Titulli:

**PLANI I INSTALIMEVE TE NDRICIMIT
RRUGOR Pk 81-95**

Shkalla:

1:500

Nr :

E-07

Data:

2022

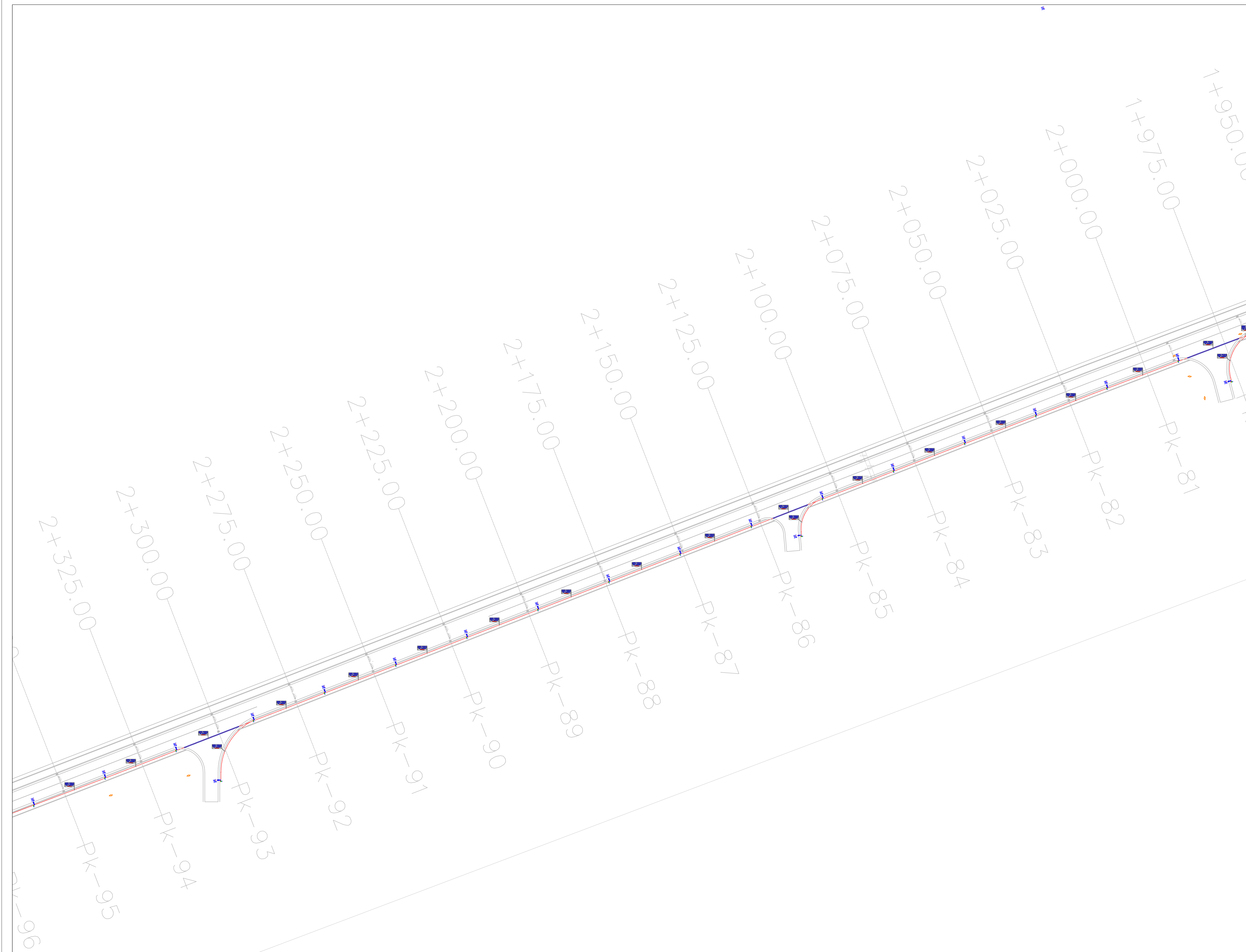



Klienti:

BASHKIA LEZHË

Titulli i Projektit:

**NDËRTIMI I RRUGËS
SUPERSTRADË -
HIDROVOR (TALE)**

Faza:

PROJEKT ZBATIMI

Projektuesi:



"STATENG" SH.P.K N. 6965/3

Inxh.Ndërt. ALTIN SERANAJ K. 2455/2

Inxh.Ndërt. ARSELA VOGLI

Inxh.Elek. ARJAN SHYTI E. 1126/3

Inxh.Gjeodet ERION LAMI T. 1111/1

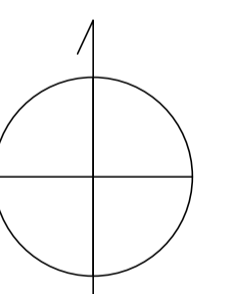

Kapitulli:

PROJEKTI ELEKTRIK

Titulli:

**PLANI I INSTALIMEVE TE NDRICIMIT
RRUGOR Pk 96-111**

Shkalla:

1:500

Nr :

E-08

Data:

2022

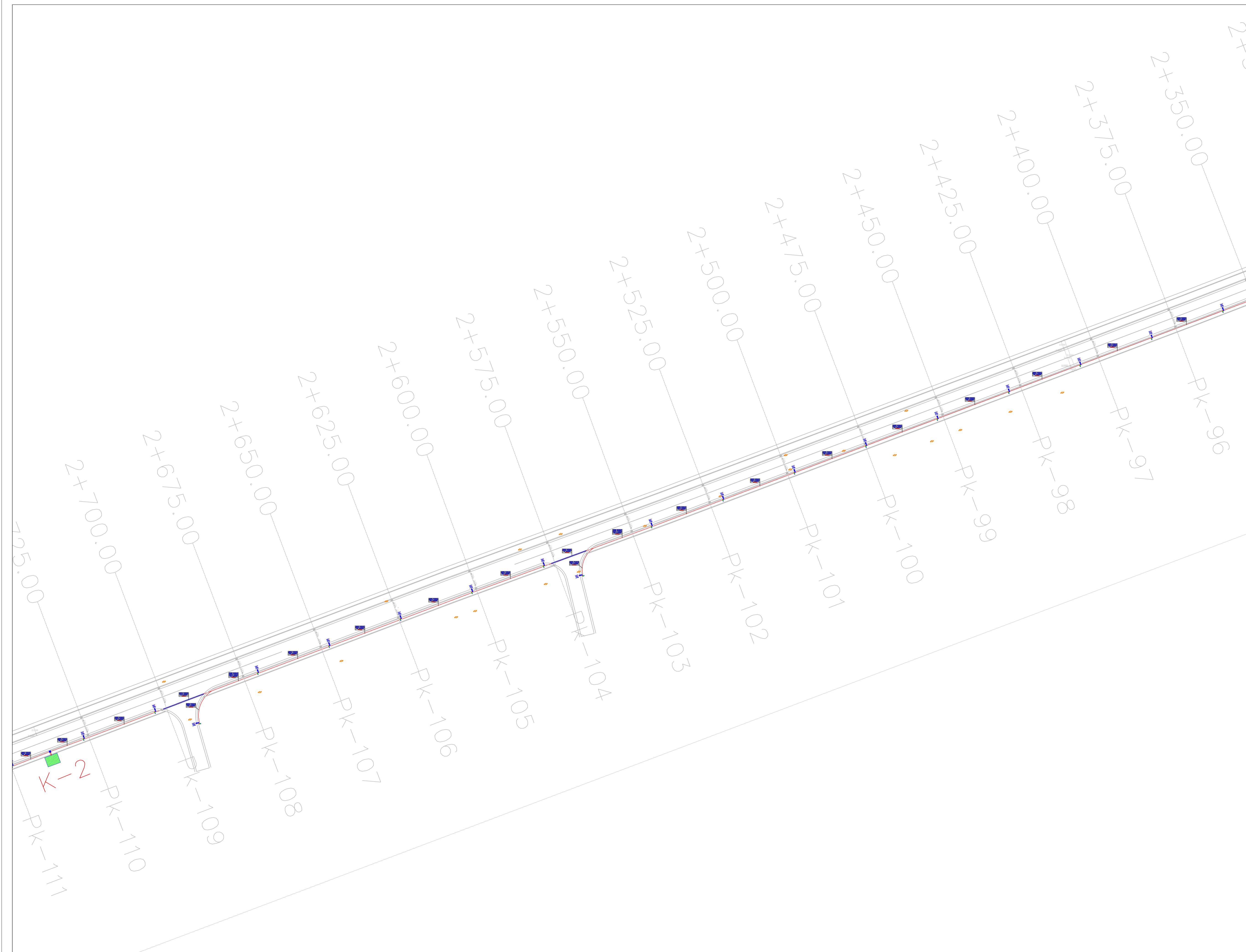



Klienti:

BASHKIA LEZHË

Titulli i Projektit:

**NDËRTIMI I RRUGËS
SUPERSTRADË -
HIDROVOR (TALE)**

Faza:

PROJEKT ZBATIMI

Projektuesi:



"STATENG" SH.P.K N. 6965/3

Inxh.Ndërt. ALTIN SERANAJ K. 2455/2

Inxh.Ndërt. ARSELA VOGLI

Inxh.Elek. ARJAN SHYTI E. 1126/3

Inxh.Gjeodet ERION LAMI T. 1111/1

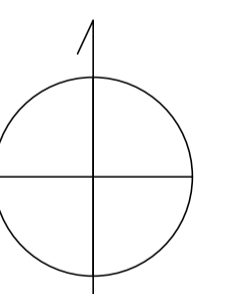

Kapitulli:

PROJEKTI ELEKTRIK

Titulli:

**PLANI I INSTALIMEVE TE NDRICIMIT
RRUGOR PK 112-126**

Shkalla:

1:500

Nr :

E-09

Data:

2022

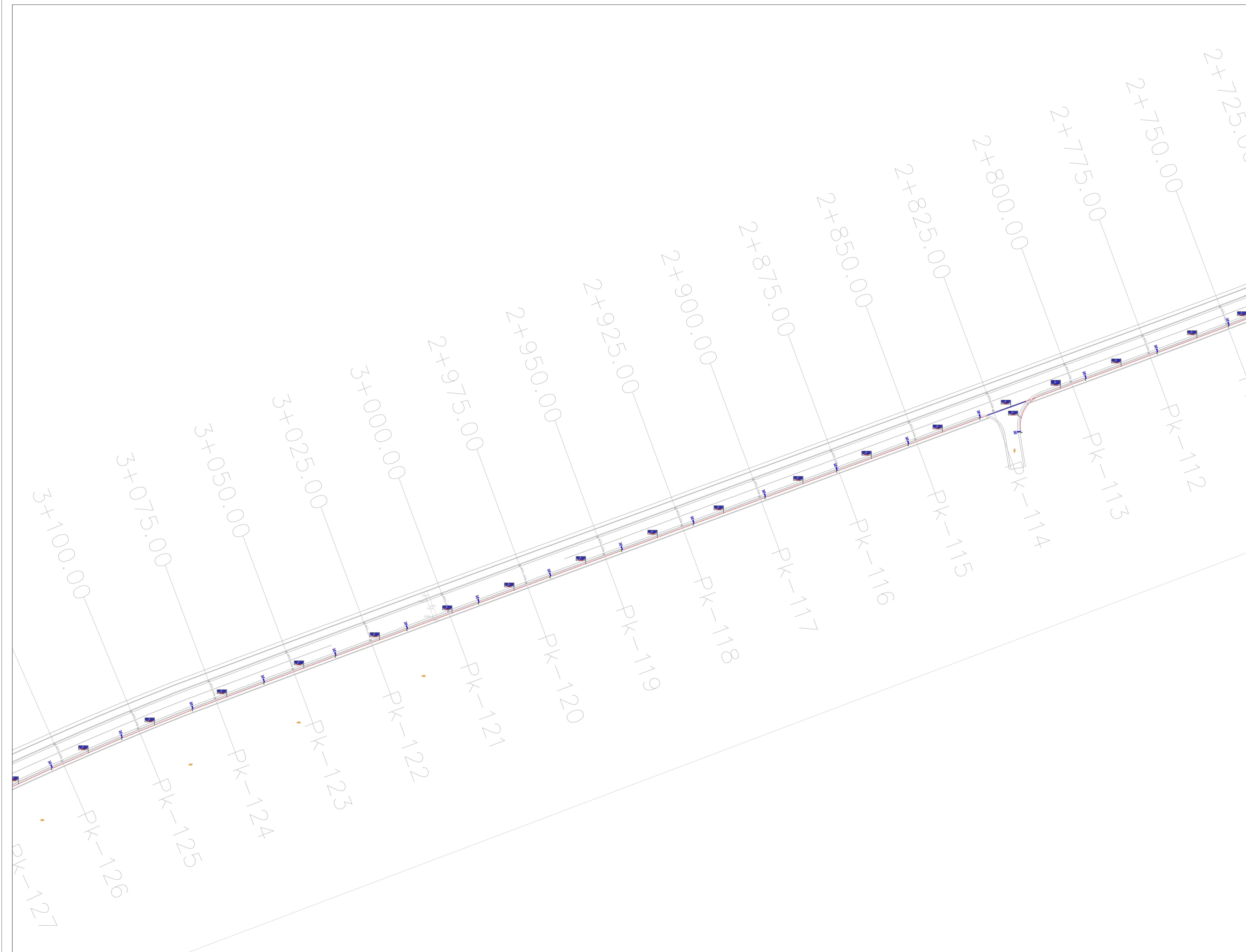



Klienti:

BASHKIA LEZHË

Titulli i Projektit:

**NDËRTIMI I RRUGËS
SUPERSTRADË -
HIDROVOR (TALE)**

Faza:

PROJEKT ZBATIMI

Projektuesi:

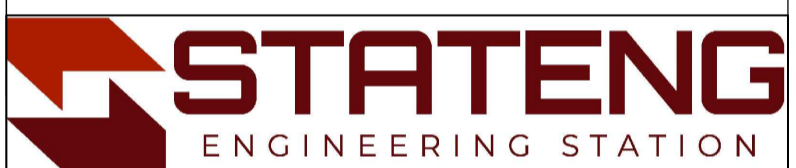

"STATENG" SH.P.K N. 6965/3

Inxh.Ndërt. ALTIN SERANAJ K. 2455/2

Inxh.Ndërt. ARSELA VOGLI

Inxh.Elek. ARJAN SHYTI E. 1126/3

Inxh.Gjeodet. ERION LAMI T. 1111/1

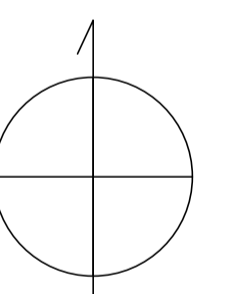

Kapitulli:

PROJEKTI ELEKTRIK

Titulli:

**PLANI I INSTALIMEVE TE NDRICIMIT
RRUGOR PK 127-142**

Shkalla:

1:500

Nr :

E-10

Data:

2022

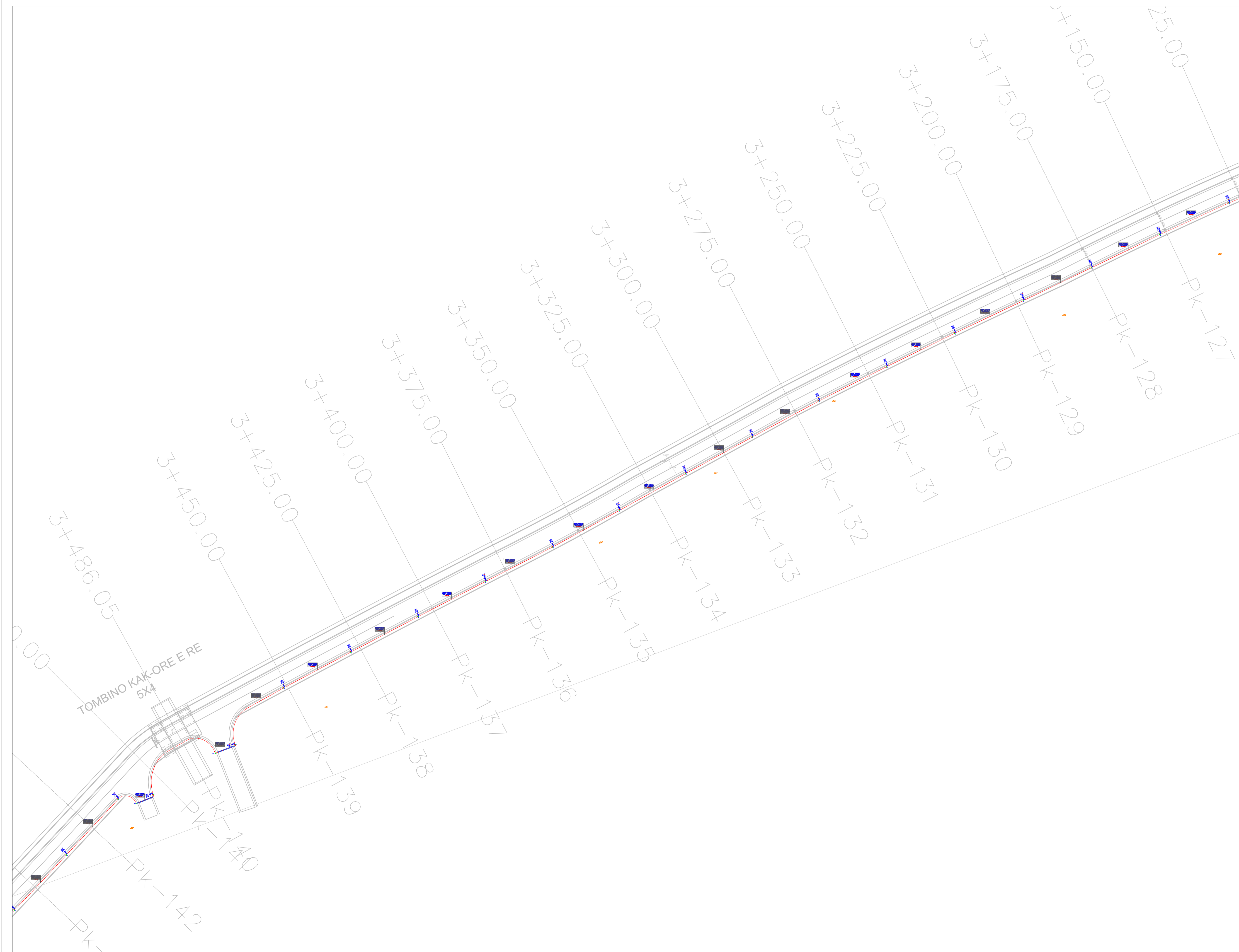



Klienti:

BASHKIA LEZHË

Titulli i Projektit:

**NDËRTIMI I RRUGËS
SUPERSTRADË -
HIDROVOR (TALE)**

Faza:

PROJEKT ZBATIMI

Projektuesi:

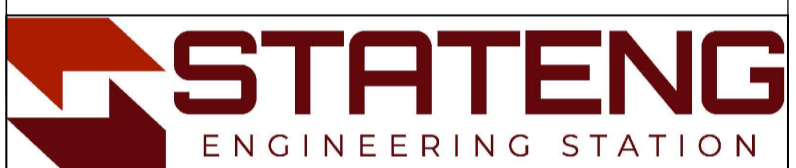

"STATENG" SH.P.K N. 6965/3

Inxh.Ndërt. ALTIN SERANAJ K. 2455/2

Inxh.Ndërt. ARSELA VOGLI

Inxh.Elek. ARJAN SHYTI E. 1126/3

Inxh.Gjeodet ERION LAMI T. 1111/1

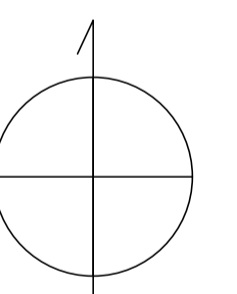

Kapitulli:

PROJEKTI ELEKTRIK

Titulli:

**PLANI I INSTALIMEVE TE NDRICIMIT
RRUGOR PK 143-157**

Shkalla:

1:500

Nr :

E-11

Data:

2022

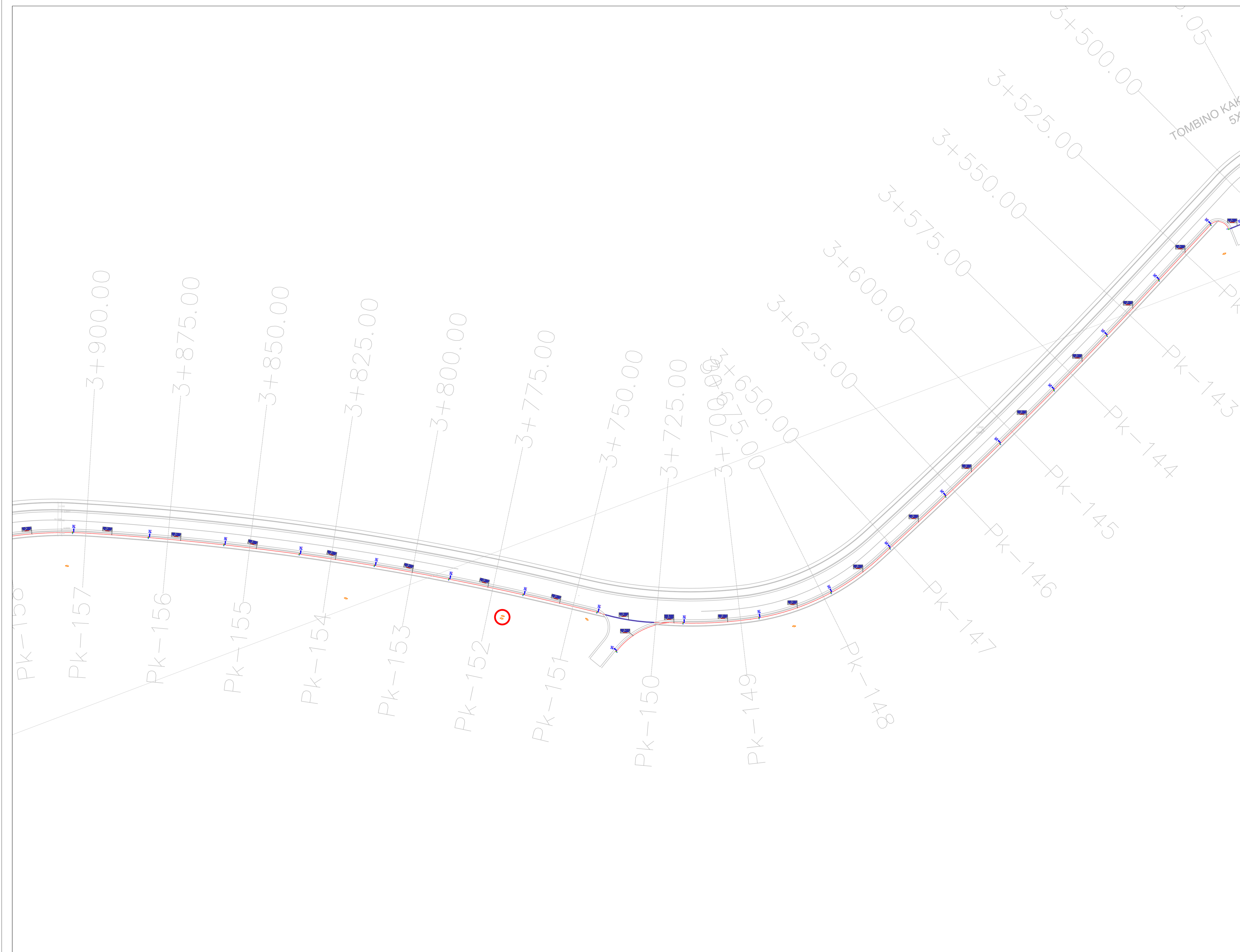



Klienti:

BASHKIA LEZHË

Titulli i Projektit:

**NDËRTIMI I RRUGËS
SUPERSTRADË -
HIDROVOR (TALE)**

Faza:

PROJEKT ZBATIMI

Projektuesi:



"STATENG" SH.P.K N. 6965/3

Inxh.Ndërt. ALTIN SERANAJ K. 2455/2

Inxh.Ndërt. ARSELA VOGLI

Inxh.Elek. ARJAN SHYTI E. 1126/3

Inxh.Gjeodet ERION LAMI T. 1111/1

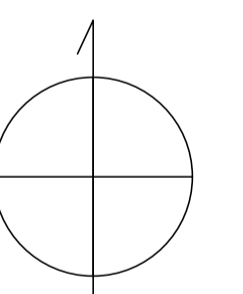

Kapitulli:

PROJEKTI ELEKTRIK

Titulli:

**PLANI I INSTALIMEVE TE NDRICIMIT
RRUGOR PK 158-173**

Shkalla:

1:500

Nr :

E-12

Data:

2022

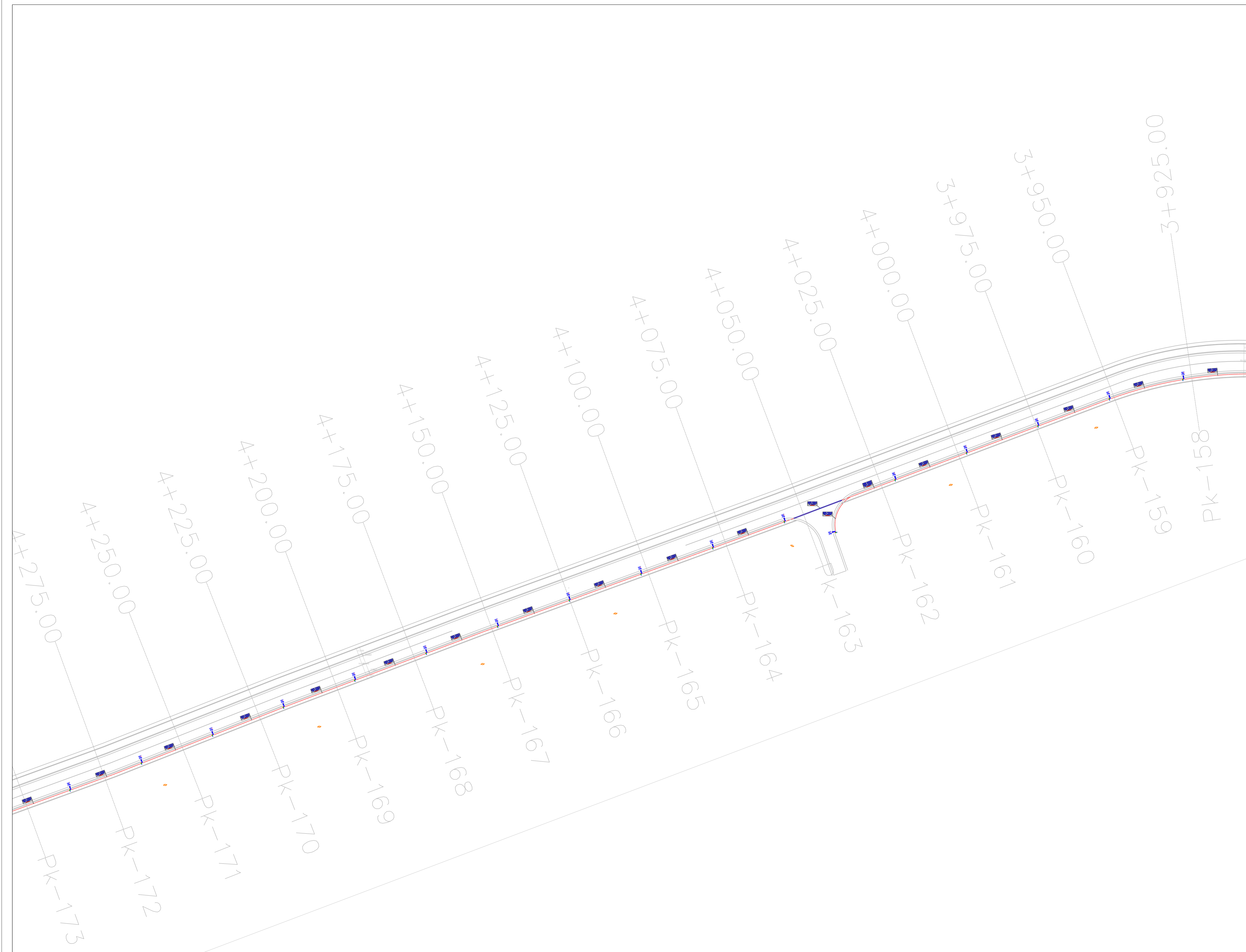



Klienti:

BASHKIA LEZHË

Titulli i Projektit:

**NDËRTIMI I RRUGËS
SUPERSTRADË -
HIDROVOR (TALE)**

Faza:

PROJEKT ZBATIMI

Projektuesi:



"STATENG" SH.P.K N. 6965/3

Inxh.Ndërt. ALTIN SERANAJ K. 2455/2

Inxh.Ndërt. ARSELA VOGLI

Inxh.Elek. ARJAN SHYTI E. 1126/3

Inxh.Gjeodet ERION LAMI T. 1111/1

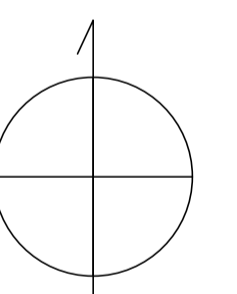

Kapitulli:

PROJEKTI ELEKTRIK

Titulli:

**PLANI I INSTALIMEVE TE NDRICIMIT
RRUGOR PK 174-188**

Shkalla:

1:500

Nr :

E-13

Data:

2022

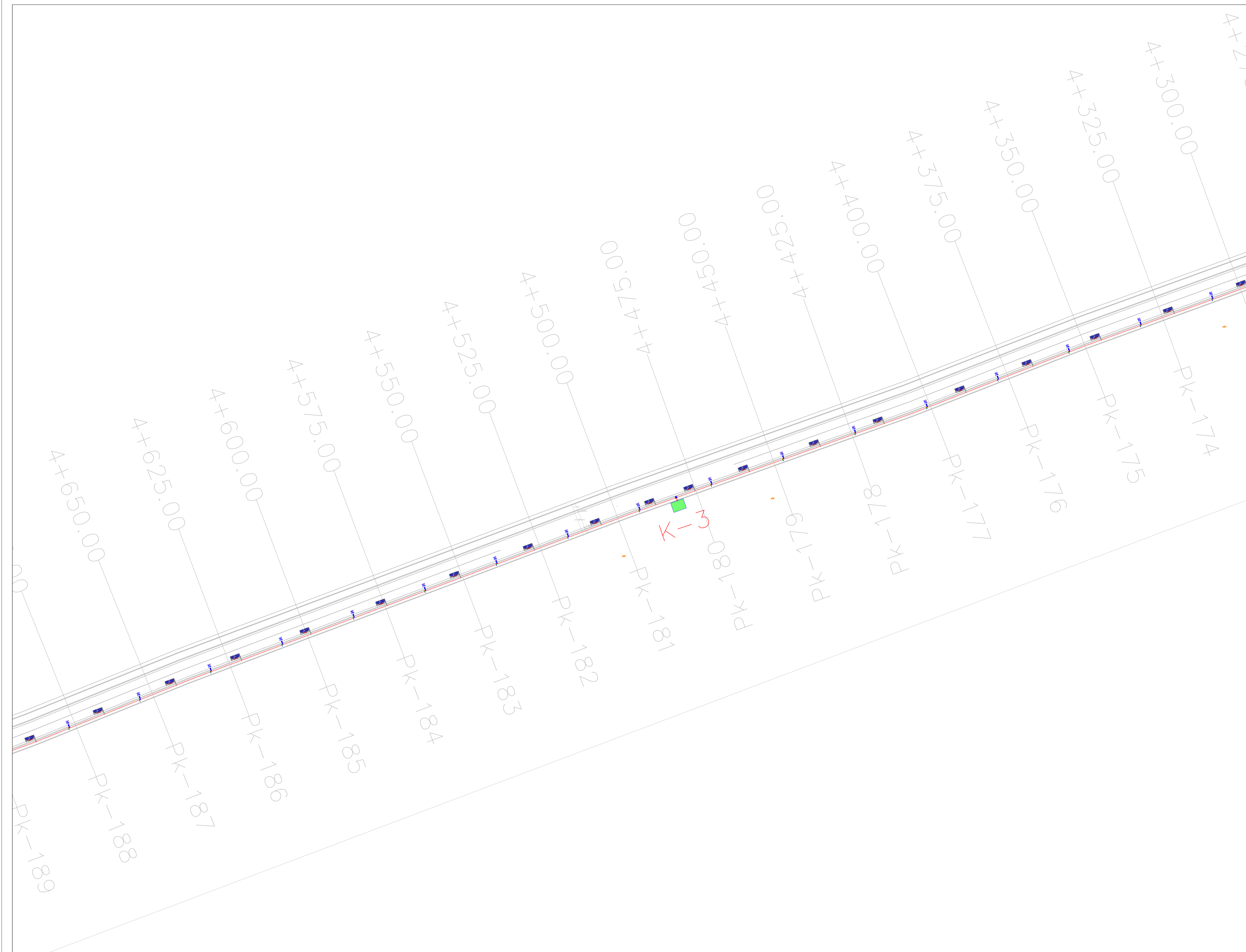



Klienti:

BASHKIA LEZHË

Titulli i Projektit:

**NDËRTIMI I RRUGËS
SUPERSTRADË -
HIDROVOR (TALE)**

Faza:

PROJEKT ZBATIMI

Projektuesi:

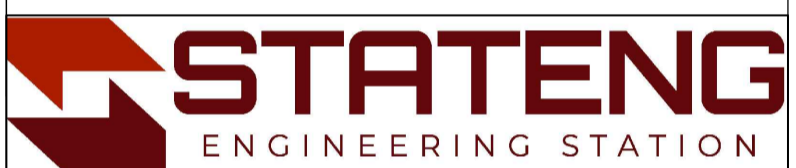

"STATENG" SH.P.K N. 6965/3

Inxh.Ndërt. ALTIN SERANAJ K. 2455/2

Inxh.Ndërt. ARSELA VOGLI

Inxh.Elek. ARJAN SHYTI E. 1126/3

Inxh.Gjeodet ERION LAMI T. 1111/1

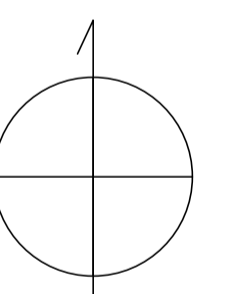

Kapitulli:

PROJEKTI ELEKTRIK

Titulli:

**PLANI I INSTALIMEVE TE NDRICIMIT
RRUGOR PK 189-203**

Shkalla:

1:500

Nr :

E-14

Data:

2022

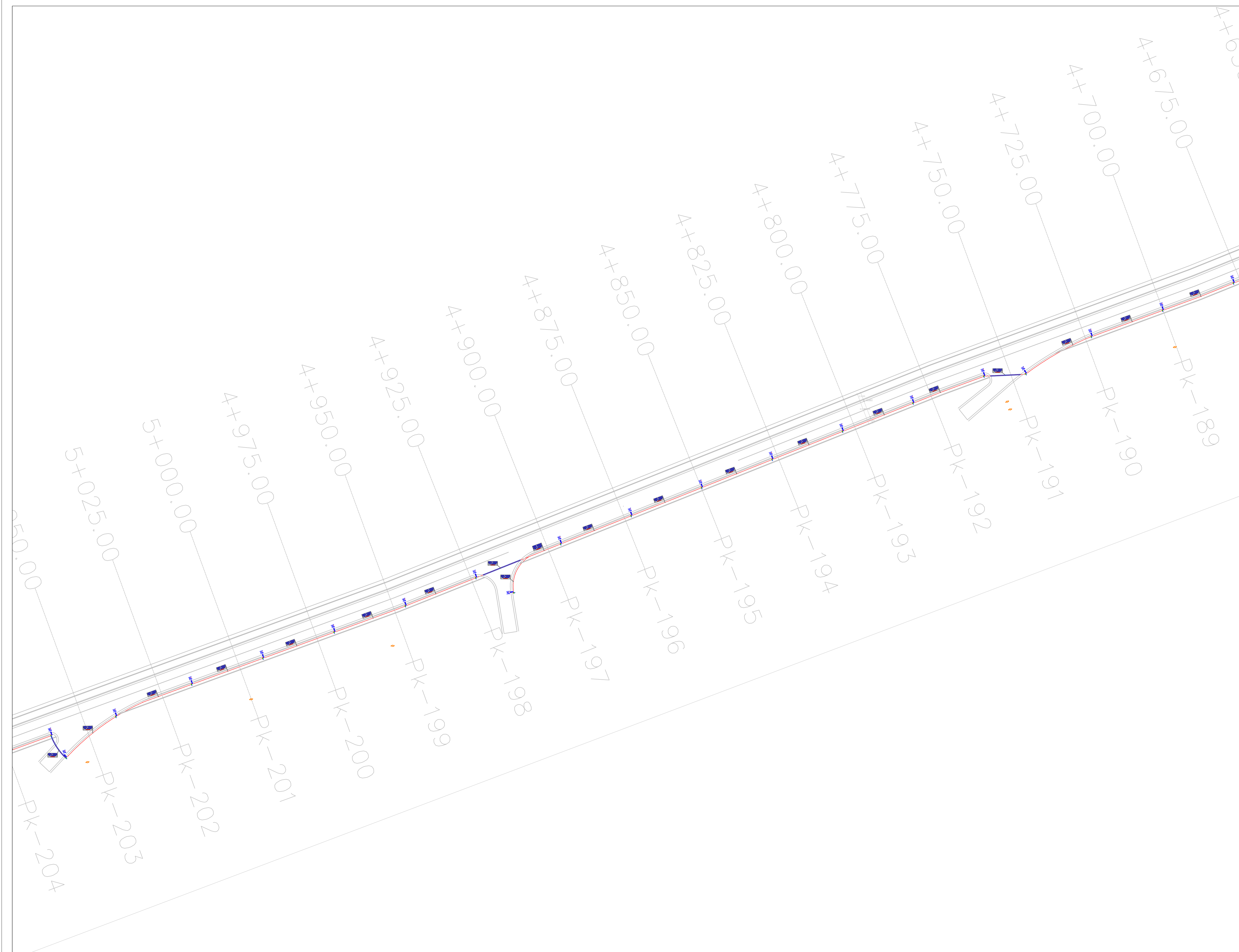



Klienti:

BASHKIA LEZHË

Titulli i Projektit:

**NDËRTIMI I RRUGËS
SUPERSTRADË -
HIDROVOR (TALE)**

Faza:

PROJEKT ZBATIMI

Projektuesi:

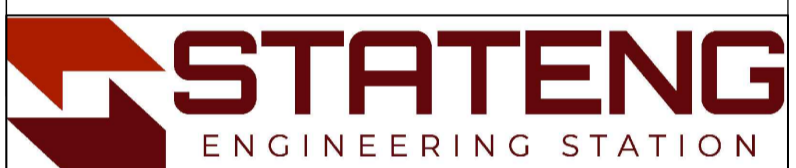

"STATENG" SH.P.K N. 6965/3

Inxh.Ndërt. ALTIN SERANAJ K. 2455/2

Inxh.Ndërt. ARSELA VOGLI

Inxh.Elek. ARJAN SHYTI E. 1126/3

Inxh.Gjeodet ERION LAMI T. 1111/1

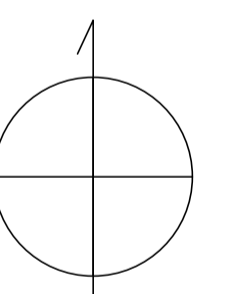

Kapitulli:

PROJEKTI ELEKTRIK

Titulli:

**PLANI I INSTALIMEVE TE NDRICIMIT
RRUGOR PK 204-218**

Shkalla:

1:500

Nr :

E-15

Data:

2022

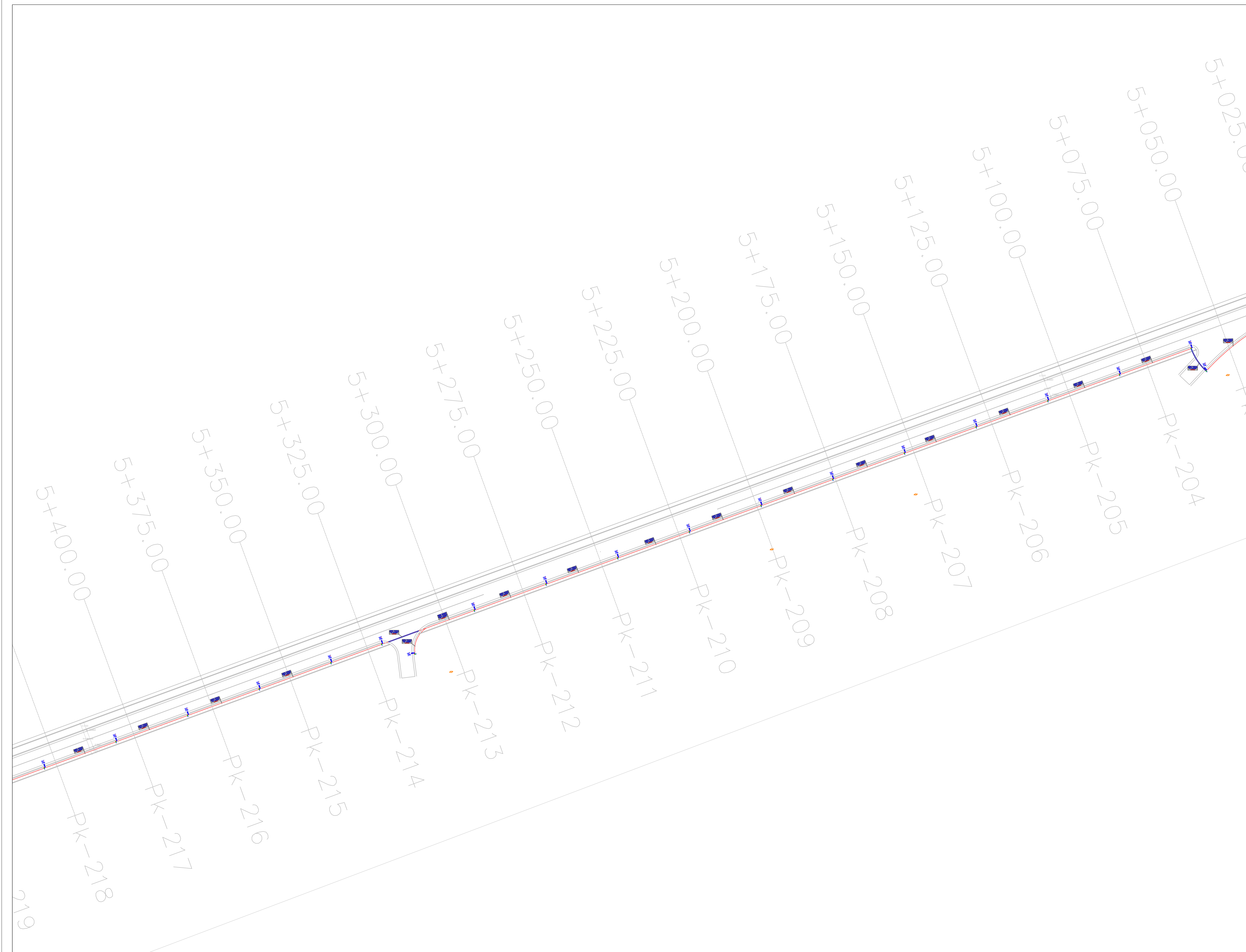



Klienti:

BASHKIA LEZHË

Titulli i Projektit:

**NDËRTIMI I RRUGËS
SUPERSTRADË -
HIDROVOR (TALE)**

Faza:

PROJEKT ZBATIMI

Projektuesi:



"STATENG" SH.P.K N. 6965/3

Inxh.Ndërt. ALTIN SERANAJ K. 2455/2

Inxh.Ndërt. ARSELA VOGLI

Inxh.Elek. ARJAN SHYTI E. 1126/3

Inxh.Gjeodet ERION LAMI T. 1111/1

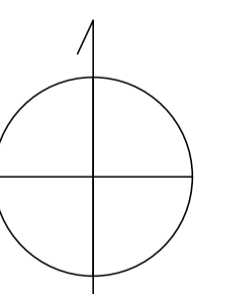

Kapitulli:

PROJEKTI ELEKTRIK

Titulli:

**PLANI I INSTALIMEVE TE NDRICIMIT
RRUGOR PK 219-234**

Shkalla:

1:500

Nr :

E-16

Data:

2022

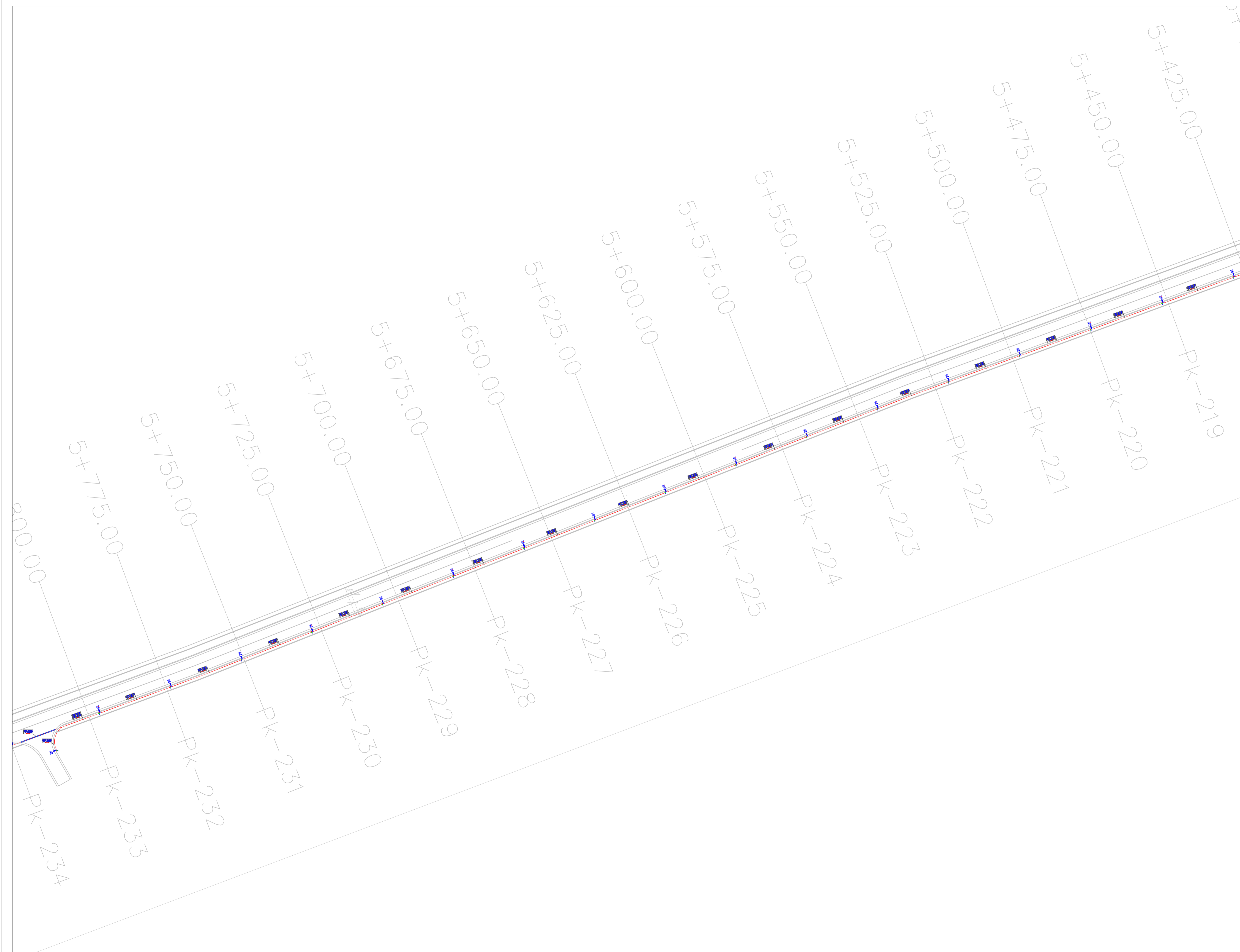



Klienti:

BASHKIA LEZHË

Titulli i Projektit:

**NDËRTIMI I RRUGËS
SUPERSTRADË -
HIDROVOR (TALE)**

Faza:

PROJEKT ZBATIMI

Projektuesi:

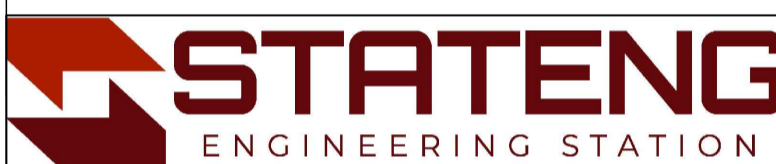

"STATENG" SH.P.K N. 6965/3

Inxh.Ndërt. ALTIN SERANAJ K. 2455/2

Inxh.Ndërt. ARSELA VOGLI

Inxh.Elek. ARJAN SHYTI E. 1126/3

Inxh.Gjeodet ERION LAMI T. 1111/1

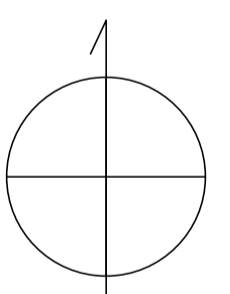

Kapitulli:

PROJEKTI ELEKTRIK

Titulli:

**PLANI I INSTALIMEVE TE NDRICIMIT
RRUGOR PK 235-249**

Shkalla:

1:500

Nr :

E-17

Data:

2022

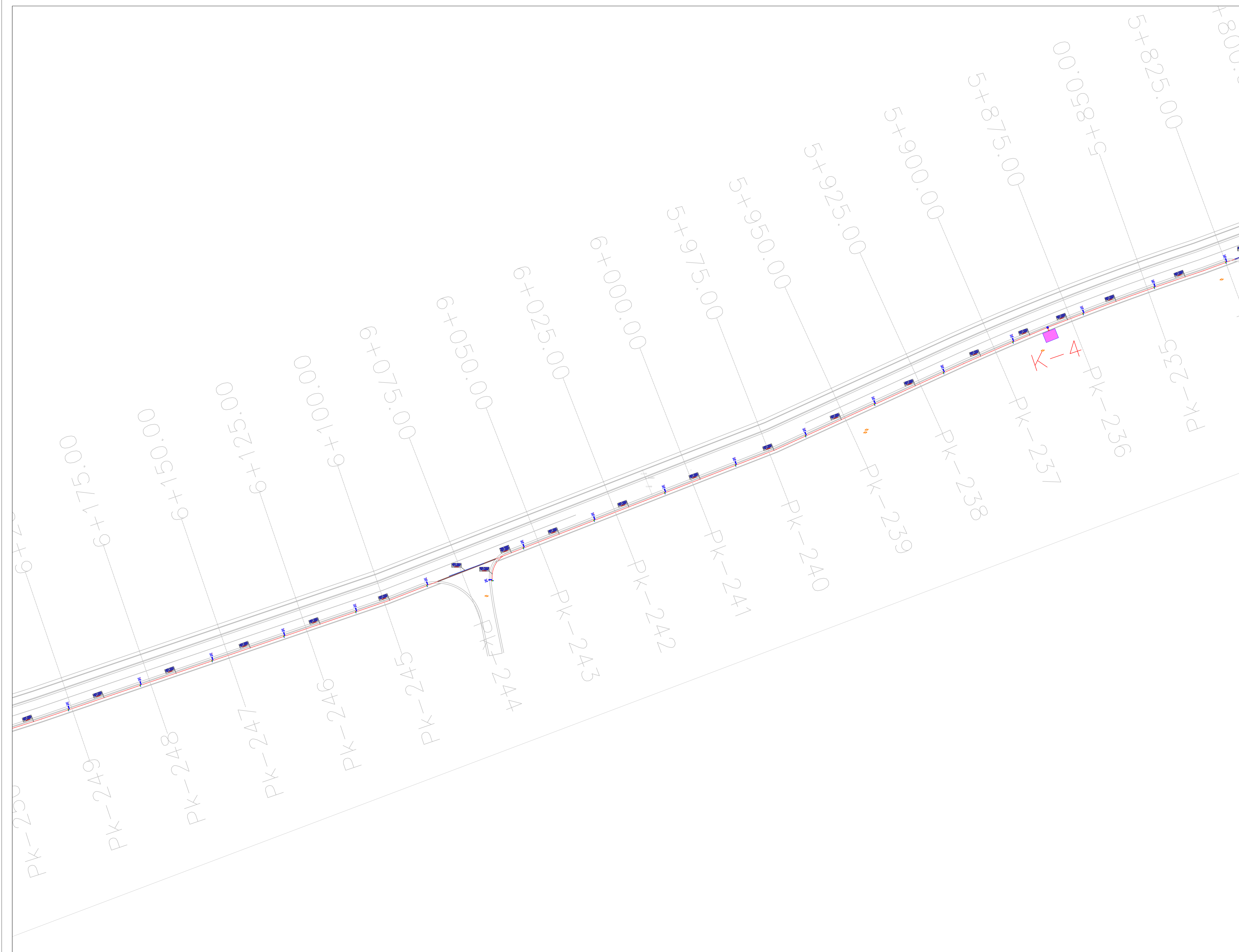



Klienti:

BASHKIA LEZHË

Titulli i Projektit:

**NDËRTIMI I RRUGËS
SUPERSTRADË -
HIDROVOR (TALE)**

Faza:

PROJEKT ZBATIMI

Projektuesi:



"STATENG" SH.P.K N. 6965/3

Inxh.Ndërt. ALTIN SERANAJ K. 2455/2

Inxh.Ndërt. ARSELA VOGLI

Inxh.Elek. ARJAN SHYTI E. 1126/3

Inxh.Gjeodet ERION LAMI T. 1111/1

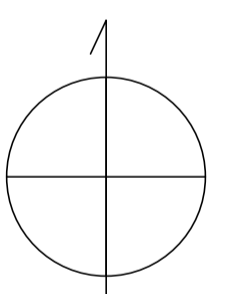

Kapitulli:

PROJEKTI ELEKTRIK

Titulli:

**PLANI I INSTALIMEVE TE NDRICIMIT
RRUGOR PK 250-256**

Shkalla:

1:500

Nr :

E-18

Data:

2022

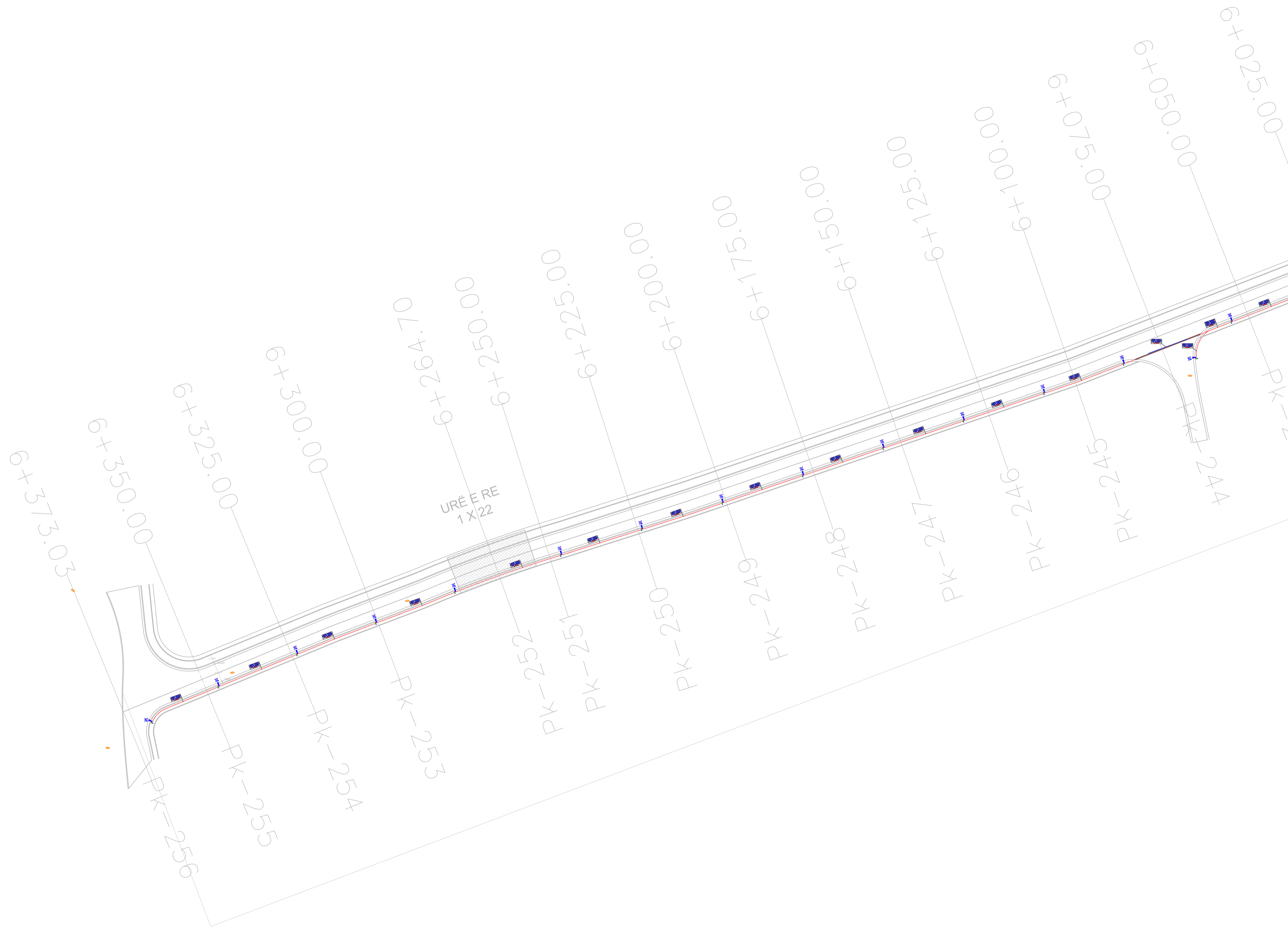



Klienti:

BASHKIA LEZHË

Titulli i Projektit:

**NDËRTIMI I RRUGËS
SUPERSTRADË -
HIDROVOR (TALE)**

Faza:

PROJEKT ZBATIMI

Projektuesi:



STATENG SH.P.K N. 6965/3

Inxh.Ndërt. ALTIN SERANAJ K. 2455/2

Inxh.Ndërt. ARSELA VOGLI

Inxh.Elek. ARJAN SHYTI E. 1126/3

Inxh.Gjeodet ERION LAMI T. 1111/1

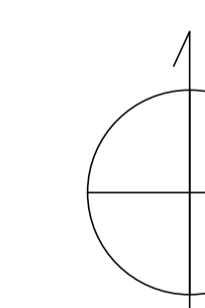

Kapitulli:

PROJEKTI ELEKTRIK

Titulli:

**PLANI I PERGJITHSEM I
INFRASTRUKTURES
TELEKOMUNIKACION**

Shkalla:

1:5000

Nr :

E-19

Data:

2022

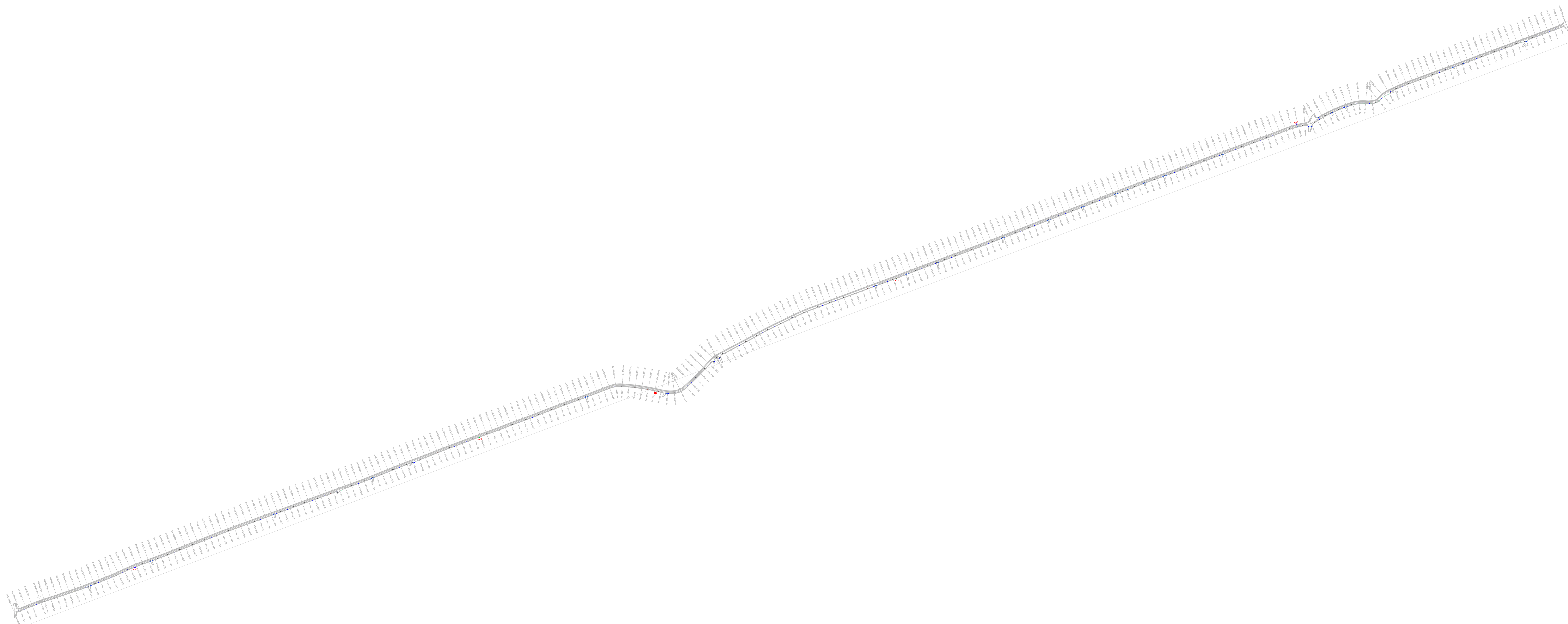



SEKSIONI TËRTHOR TIP -1
(rasti me kufizim të murit rrethues majtas)

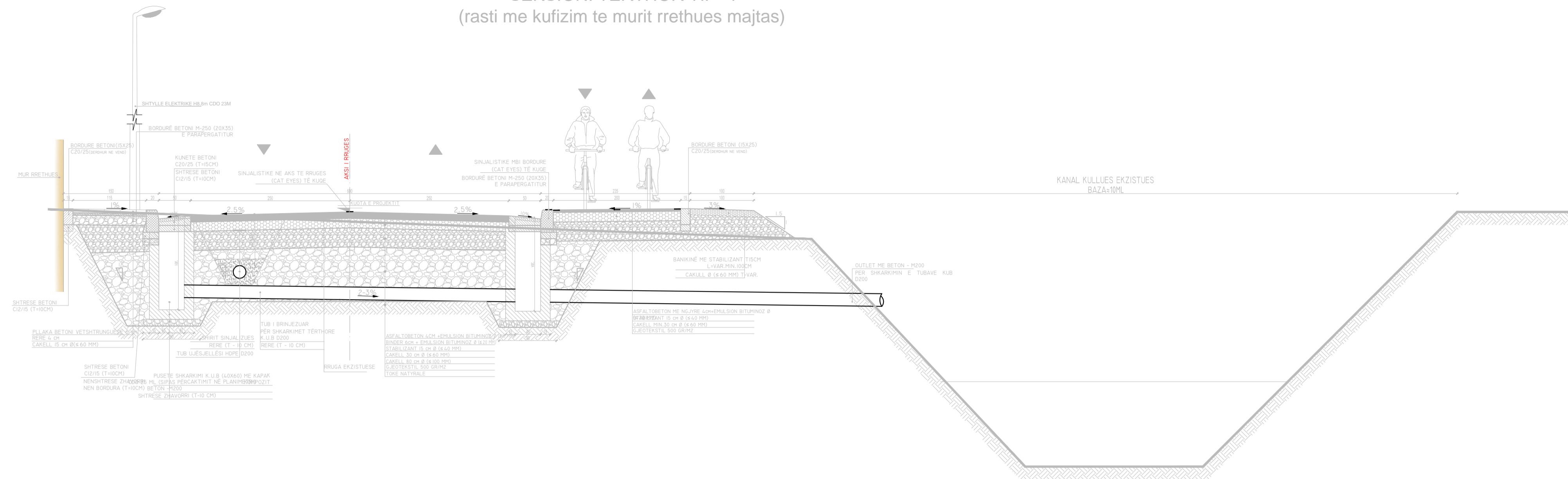

SEKSIONI TËRTHOR TIP -2
(rasti me mbushje me shkallëzim të trupit të rrugës në të dyja krahët)

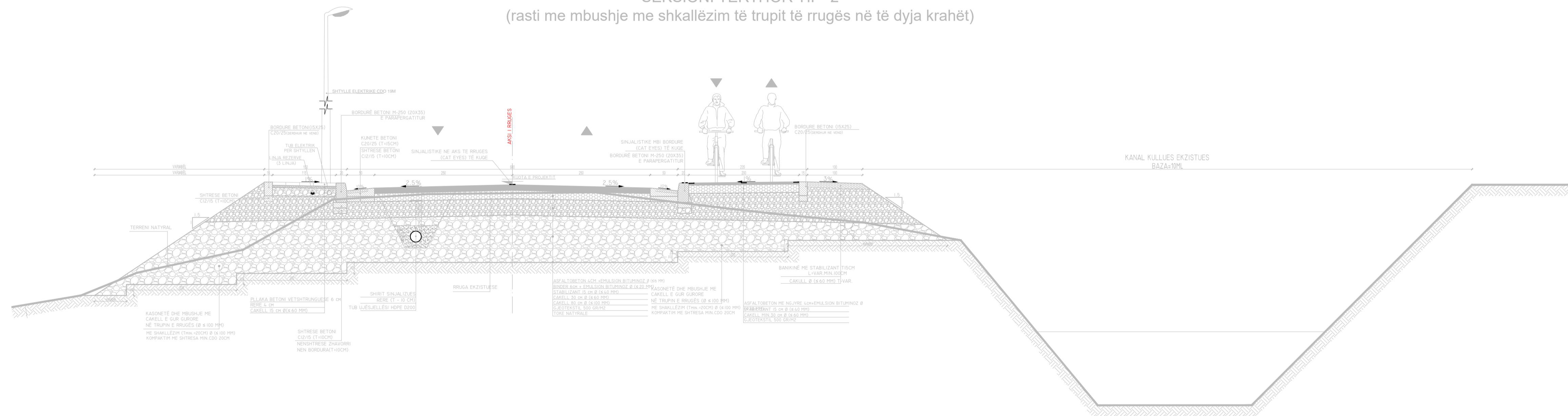

SEKSIONI TËRTHOR TIP -3
(rasti me gërmim në skarpatë majtas dhe mbushje me shkallëzim djathtas)

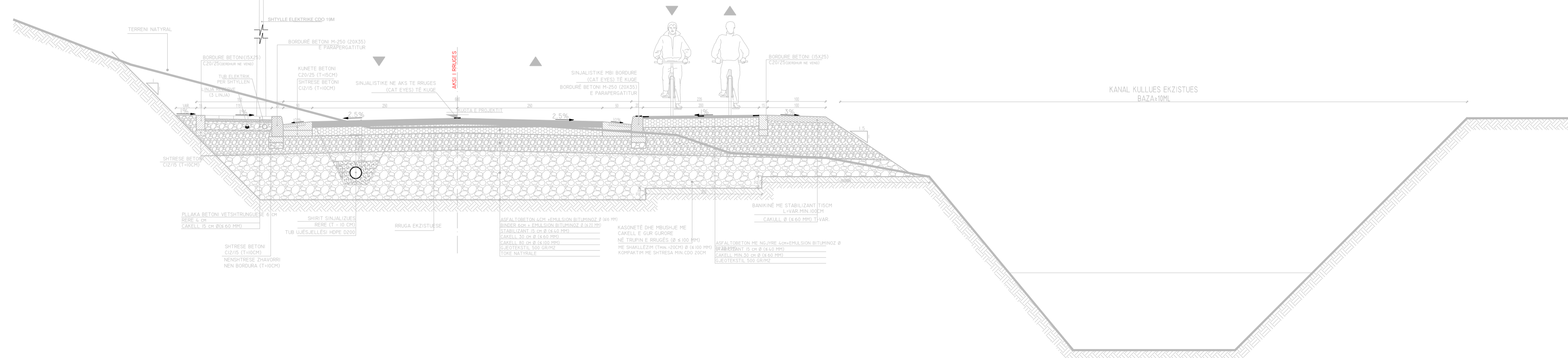

Klienti:

BASHKIA LEZHË

Titulli i Projektit:

**NDËRTIMI I RRUGËS
SUPERSTRADË -
HIDROVOR (TALE)**

Faza:

PROJEKT ZBATIMI

Projektuesi:

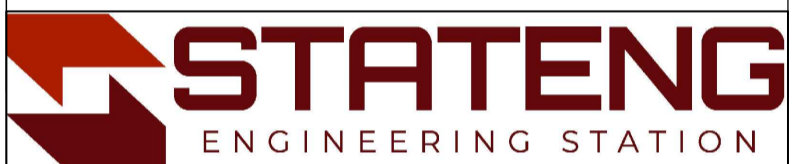

"STATENG" SH.P.K		N. 6965/3
Inxh.Ndërt.	ALTIN SERANAJ	K. 2455/2
Inxh.Ndërt.	ARSELA VOGLI	
Inxh.Elek.	ARJAN SHYTI	E. 1126/3
Inxh.Gjeodet	ERION LAMI	T. 1111/1

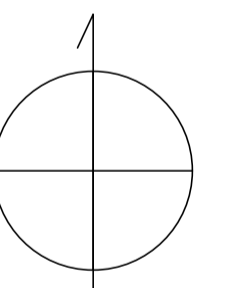

Kapitulli:

PROJEKTI ELEKTRIK

Titulli:

SEKSIONE TIP

Shkalla:

1:500

Nr :

E-20

Data:

2022



Klienti:

BASHKIA LEZHË

Titulli i Projektit:

**NDËRTIMI I RRUGËS
SUPERSTRADË -
HIDROVOR (TALE)**

Faza:

PROJEKT ZBATIMI

Projektuesi:

"STATENG" SH.P.K N. 6965/3

Inxh.Ndërt. ALTIN SERANAJ K. 2455/2

Inxh.Ndërt. ARSELA VOGLI

Inxh.Elek. ARJAN SHYTI E. 1126/3

Inxh.Gjeodet ERION LAMI T. 1111/1

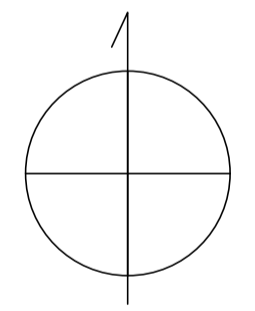

Kapitulli:

PROJEKTI ELEKTRIK

Titulli:

**SKEMA E RRJETIT ELEKTRIK TE
NDRICIMIT TE RRUGES**

Shkalla:

N/A

Nr :

E-21

Data:

2022



DETAJ INSTALIMI SHTYLLE ME GAJTESI 8.8m

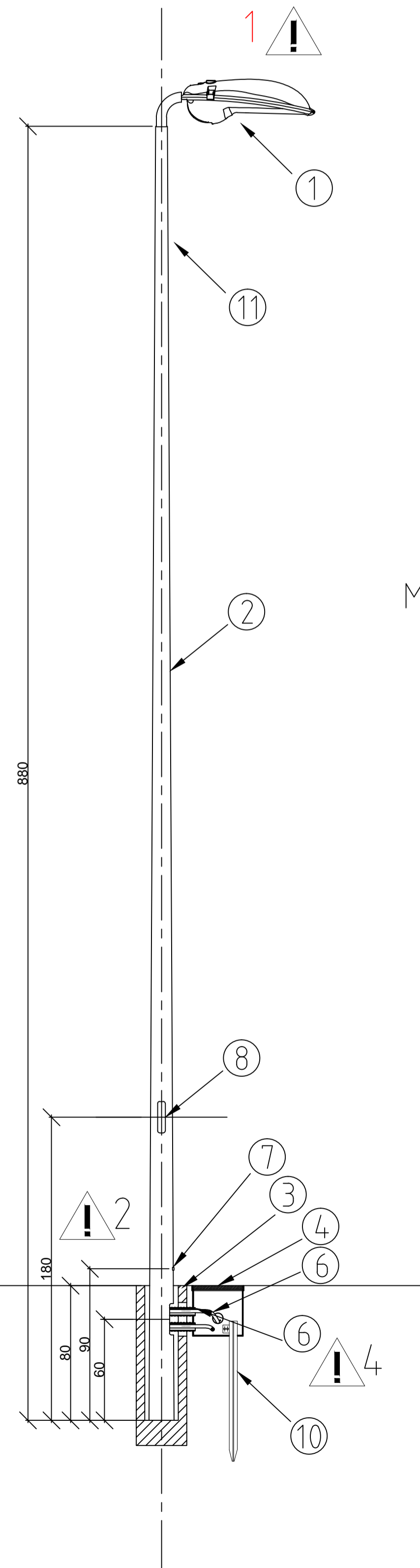

MORSETERIA E SHTYLLËS

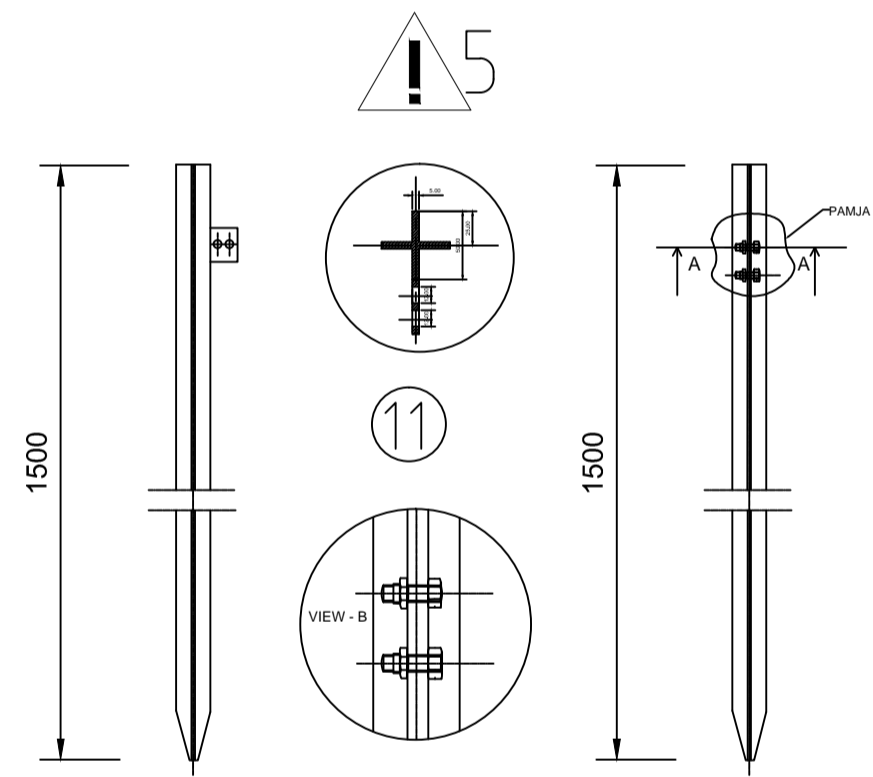
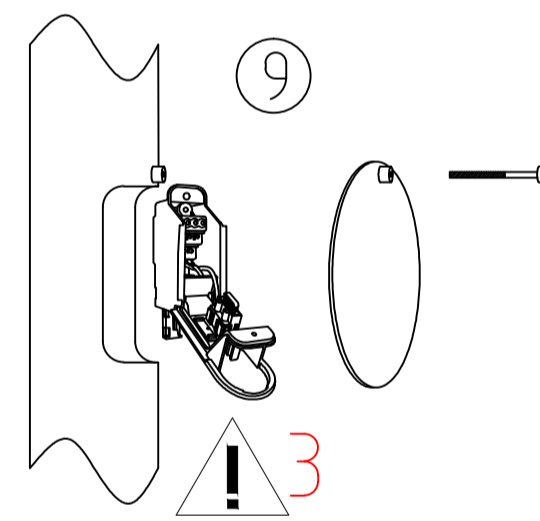

BAZAMENT SHTYLLE METALIKE PER GJATESI 8.8m



Tabela e Materjaleve

No	Pershkrimi i materjalit	Sasia	Njesia
1	Ndricules rrugor IP65 me llamp LED 116W	1	cope
2	Shtylle konike metalike e galvanizuar H=8.8 m	1	cope
3	Morseteri shtylle ndricimi 230-400V e paisur mesigurese	1	cope
4	Kapak i morseteris se shtylles	1	cope
5	Bazament shtylle ndricimi i parapregatiur M150	1	cope
6	Puset plastike RIC 1084+1086 dim = 30x30x30 cm	1	cope
7	Tub fleksibel i rende Ø32	1	ml
8	Kabell FROR 3x1.5 mm ² , per lidhje nga morseteria ne ndricues	8	ml
9	Percjelles NO7V-K 1x16mm ² me gjyre te verdh dhe jeshile	1	ml
10	Kapikorda bakri 16 mm ² me vrime Ø10 mm	2	cope
11	Elektrod tokezimi hekur i zinkuar L=1.5 m	1	cope
12	Morseta hekuri te zinkuara per elektrod tokezimi	1	cope

SHENIME:

- 1 Kendi i rrotullimit kundrejt planit te rruges 0°
- 2 Lidhja e trupit te shtylles me elektrodën e tokezimit te behet me precjelles te izoluar me seksion 1x16mm².
- 3 Percjellesat e kabllit te lidhen ne morseteri me feminalet e dhura, si dhe te sigurohet nje mbyllje e mire e kapakut te morseteris se shtylles.
- 4 Tubi i korroguar qe do te futet ne zgavren e poshteme te shtylles duhet te shkoje deri ne brendesi te saj dhe ekstremi i tubit duhet te formoj nje hark ne drejtimin e morseteris se kabllave.
- 5 Elektrodat e tokezimit do te vendosen cdo shtylle ndricimi.
- 6 Pas vendosjes se bazamentit te shtylles dhe pusetes elekK-ike ne pozicionin perfundimtar, hapsira rrethuase te mbushet me beton.

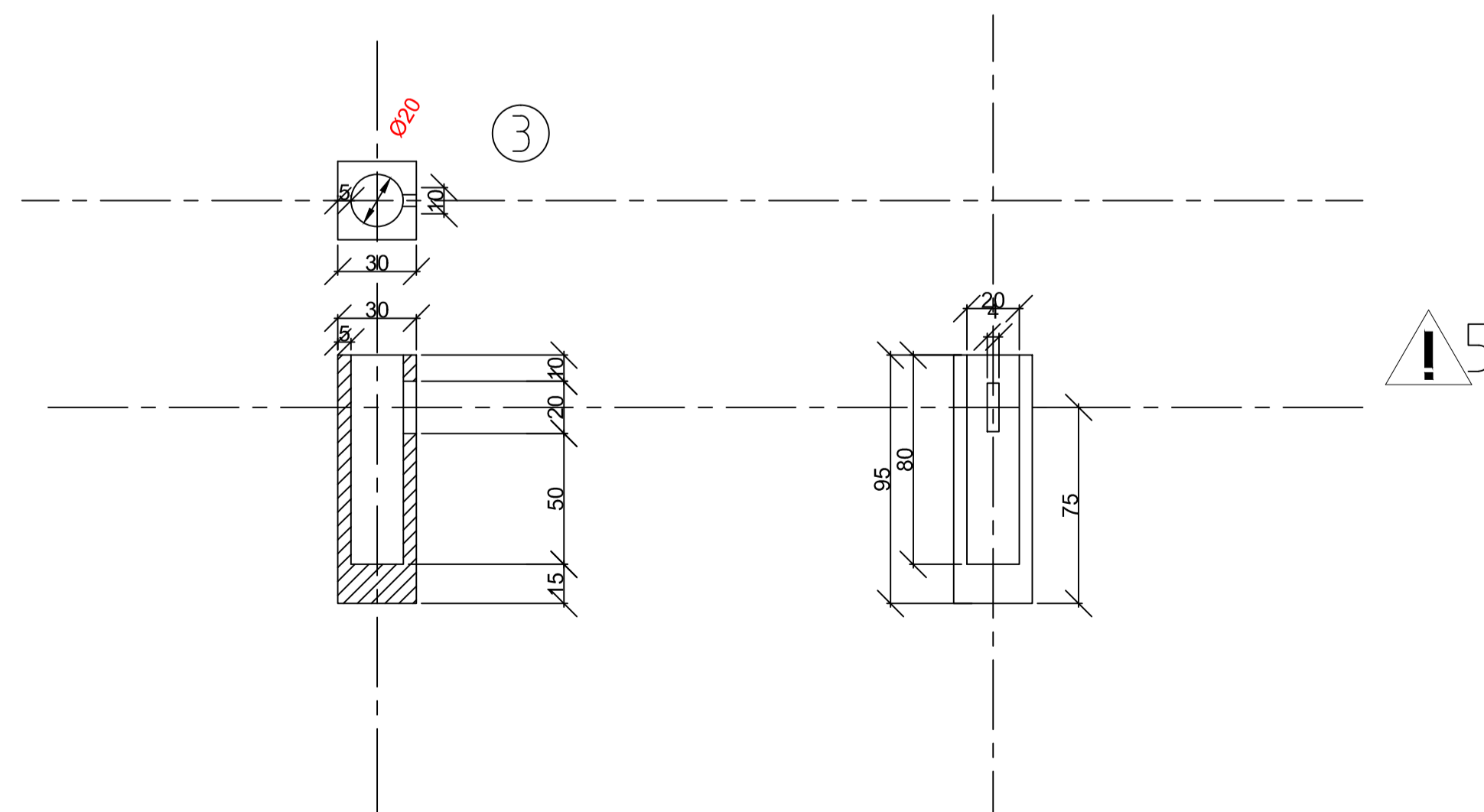
- 1 Ndricules rrugor IP65 me llamp LED 116W
- 2 Shtylle konike metalike e galvanizuar H=8.8 m
- 3 Bazament shtylle ndricimi i parapregatiur M150
- 4 Puset plastike RIC 1084+1086 30x30x30 cm
- 5 Tub i korroguar Ø32 i vendosur ne thellesine 20cm nga siperfaqja e tokes.
- 6 Kabell FG16R16 , per lidhje nga shtylla ne shtylle
- 7 Pike mosetererie per tokezimin e shtylles
- 8 Morseteri shtylle ndricimi 230-400V e paisur me sigures
- 9 Tub fleksibel i rende Ø32
- 10 Elektrod tokezimi hekur i galvanizuar L=1.5 m
- 11 Krahe shtylle ndricimi i zinkuar L=1 m



Klienti:

BASHKIA LEZHË

Titulli i Projektit:

**NDËRTIMI I RRUGËS
SUPERSTRADË -
HIDROVOR (TALE)**

Faza:

PROJEKT ZBATIMI

Projektuesi:



"STATENG" SH.P.K N. 6965/3

Inxh.Ndërt. ALTIN SERANAJ K. 2455/2

Inxh.Ndërt. ARSELA VOGLI

Inxh.Elek. ARJAN SHYTI E. 1126/3

Inxh.Gjeodet ERION LAMI T. 1111/1

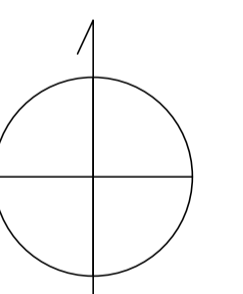

Kapitulli:

PROJEKTI ELEKTRIK

Titulli:

**DETAJE INSTALIMI TE SHTYLLAVE TE
NDRICIMIT**

Shkalla:

1:500

Nr :

E-22

Data:

2022



Klienti:

BASHKIA LEZHË

Titulli i Projektit:

**NDËRTIMI I RRUGËS
SUPERSTRADË -
HIDROVOR (TALE)**

Faza:

PROJEKT ZBATIMI

Projektuesi:



"STATENG" SH.P.K N. 6965/3

Inxh.Ndërt. ALTIN SERANAJ K. 2455/2

Inxh.Ndërt. ARSELA VOGLI

Inxh.Elek. ARJAN SHYTI E. 1126/3

Inxh.Gjeodet ERION LAMI T. 1111/1

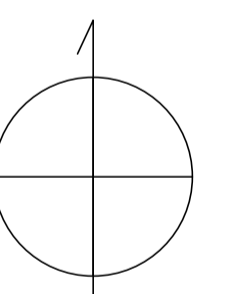

Kapitulli:

PROJEKTI ELEKTRIK

Titulli:

**DETAJE INSTALIMI PUSETA E
SHTYLLËS SE NDRICIMIT**

Shkalla:

N/A

Nr :

E-23

Data:

2022

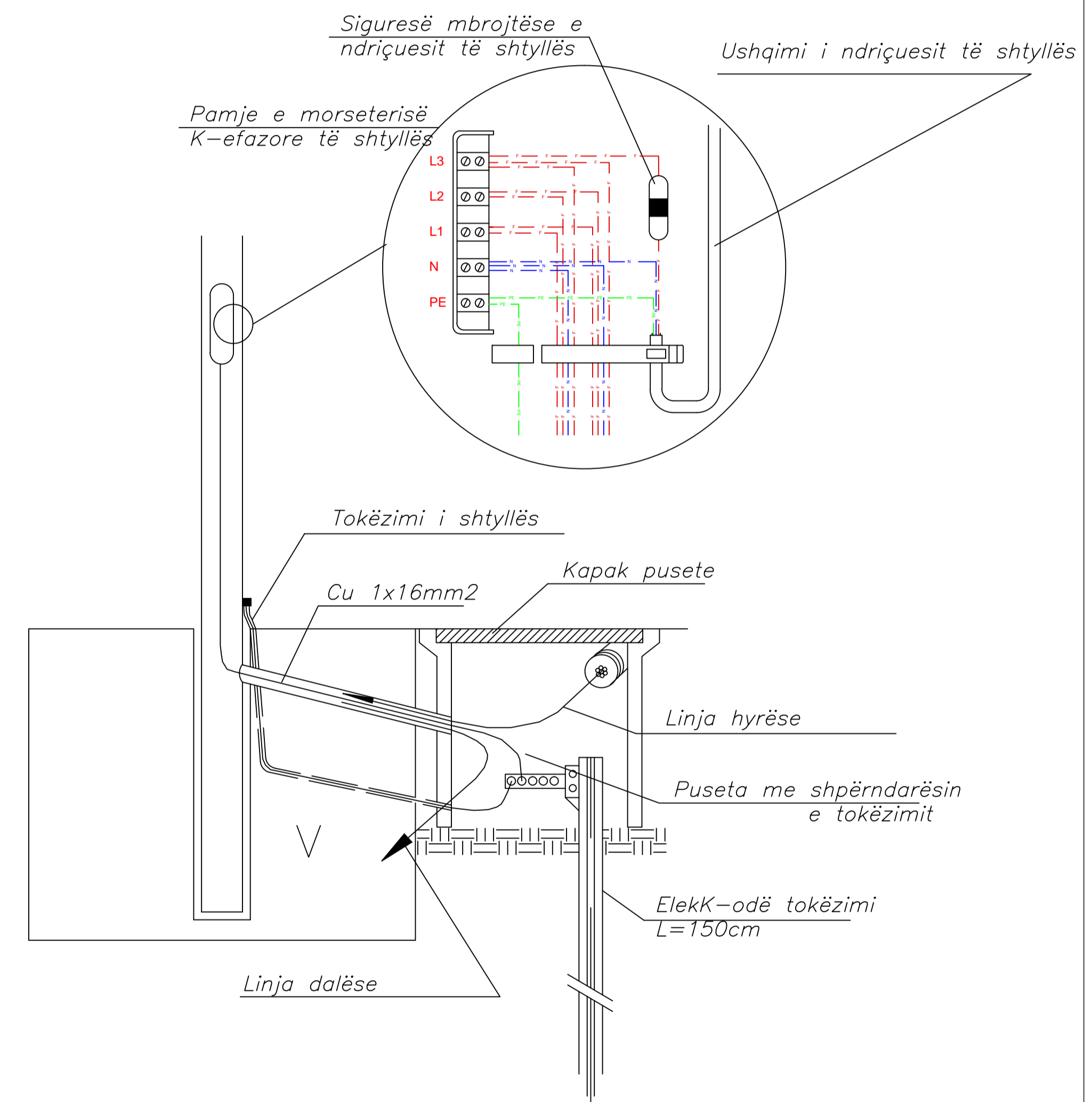
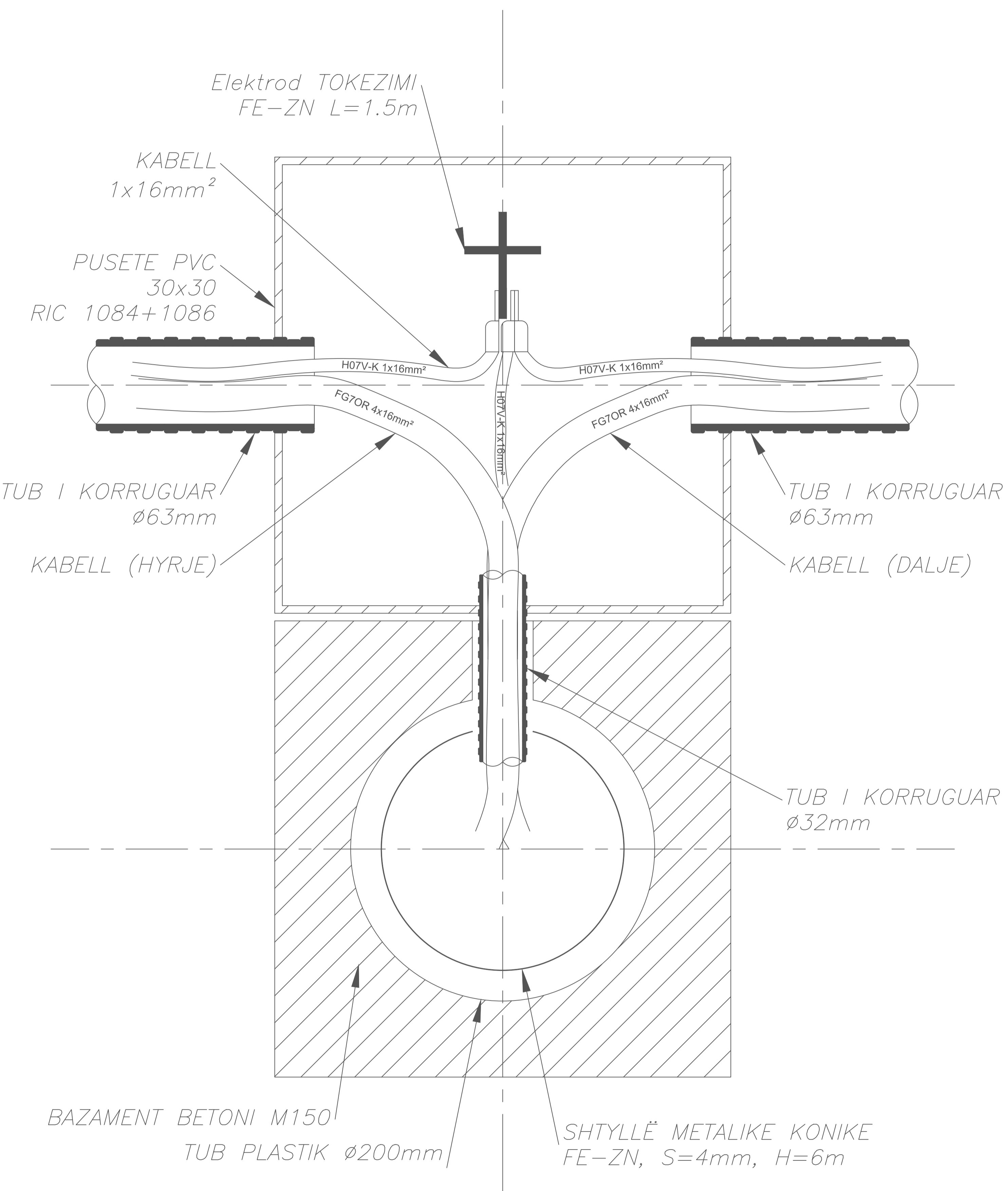

PRERJA TERTHORE E KANALIT PER SHK-IRJE TUBACIONEVE REZERVE TU & TELEKOM GJATE RRUGEVE TE ASFALTUARA

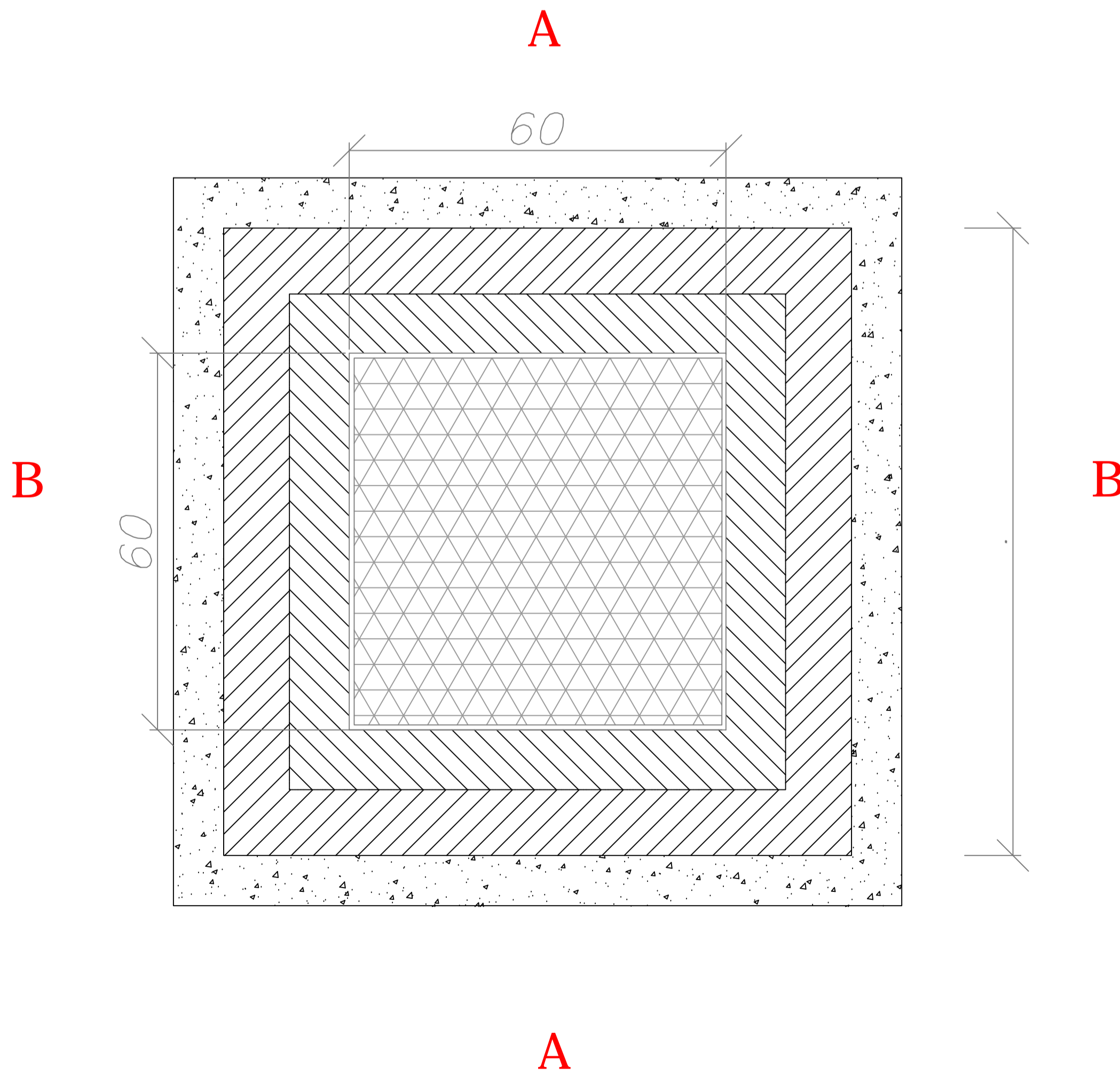
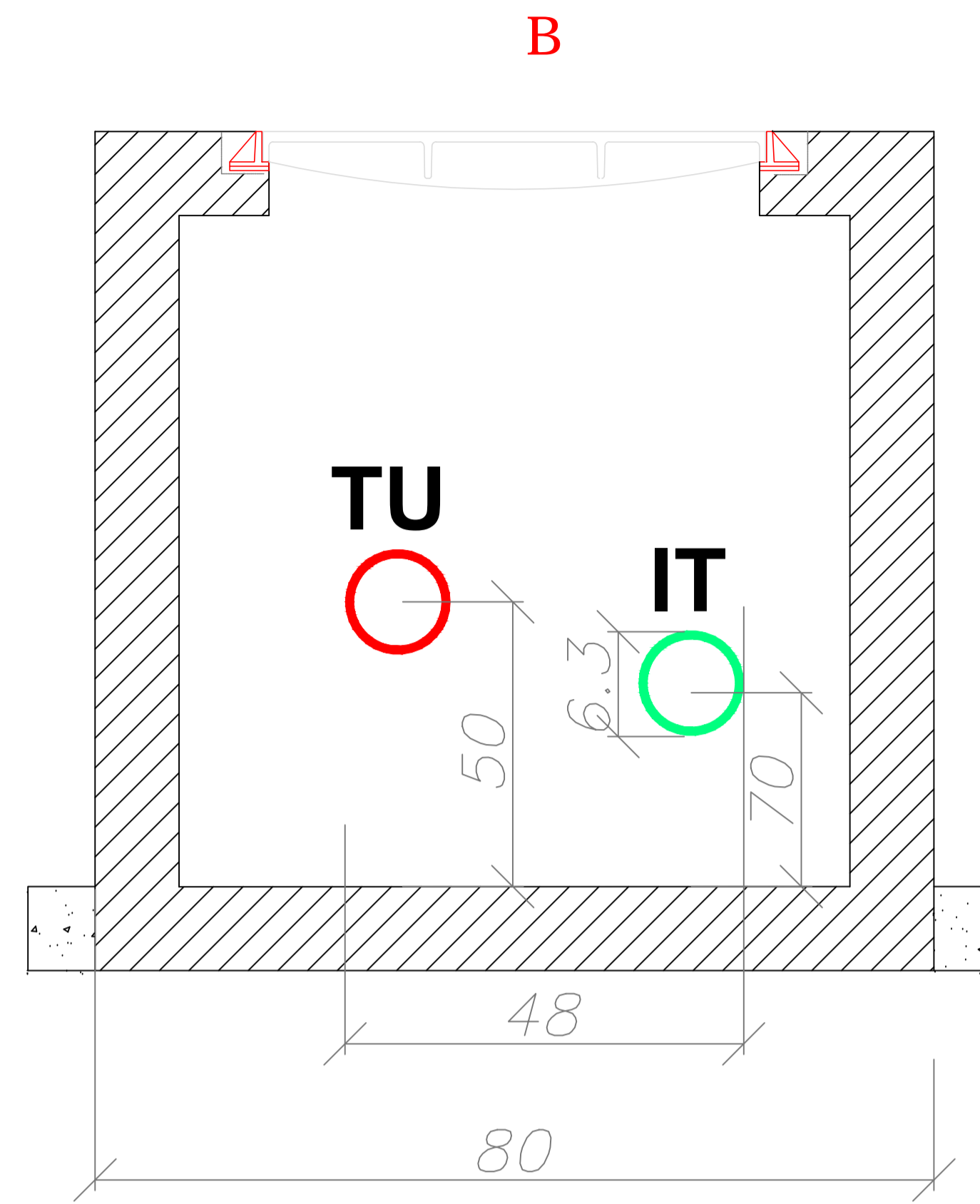
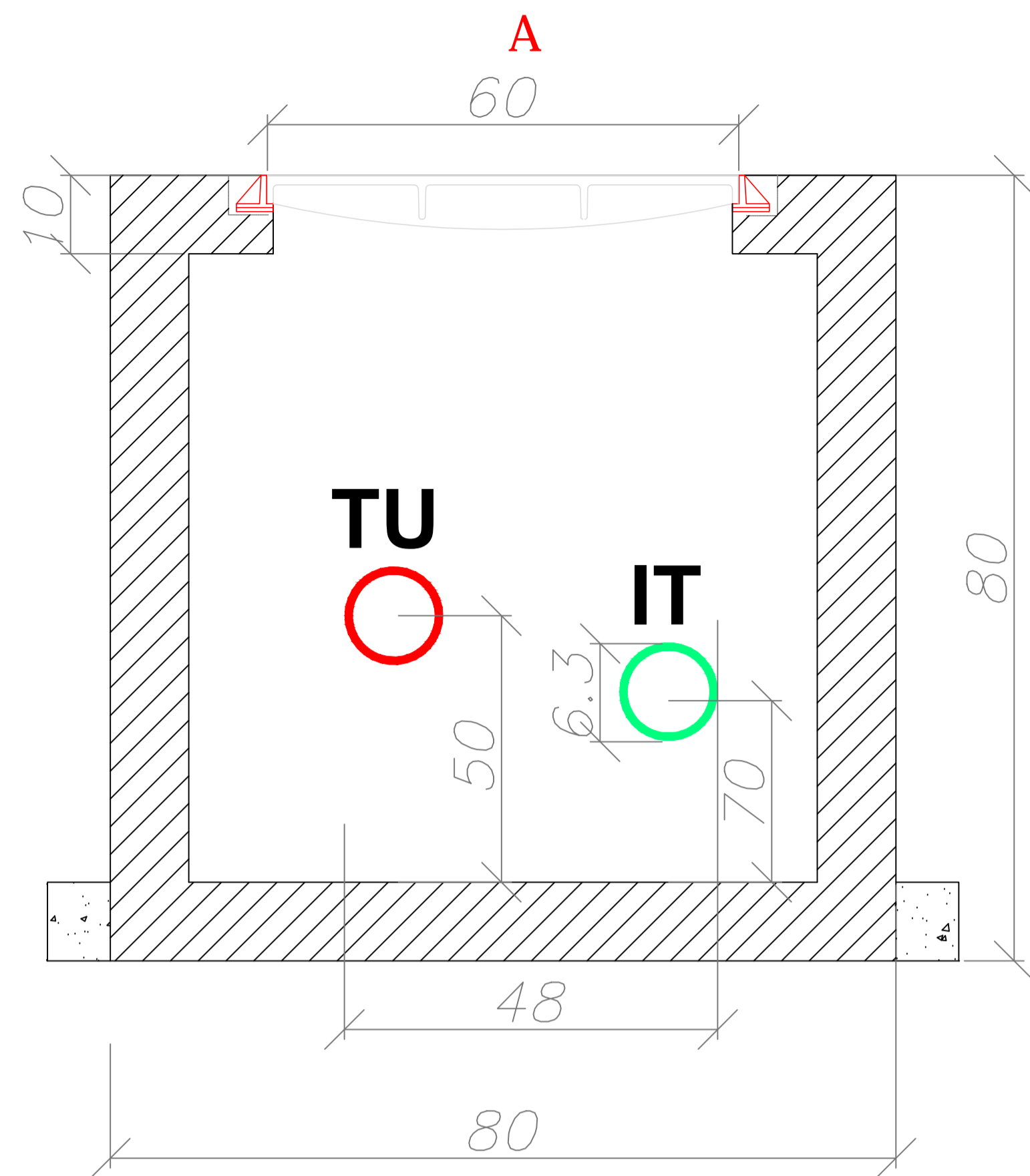
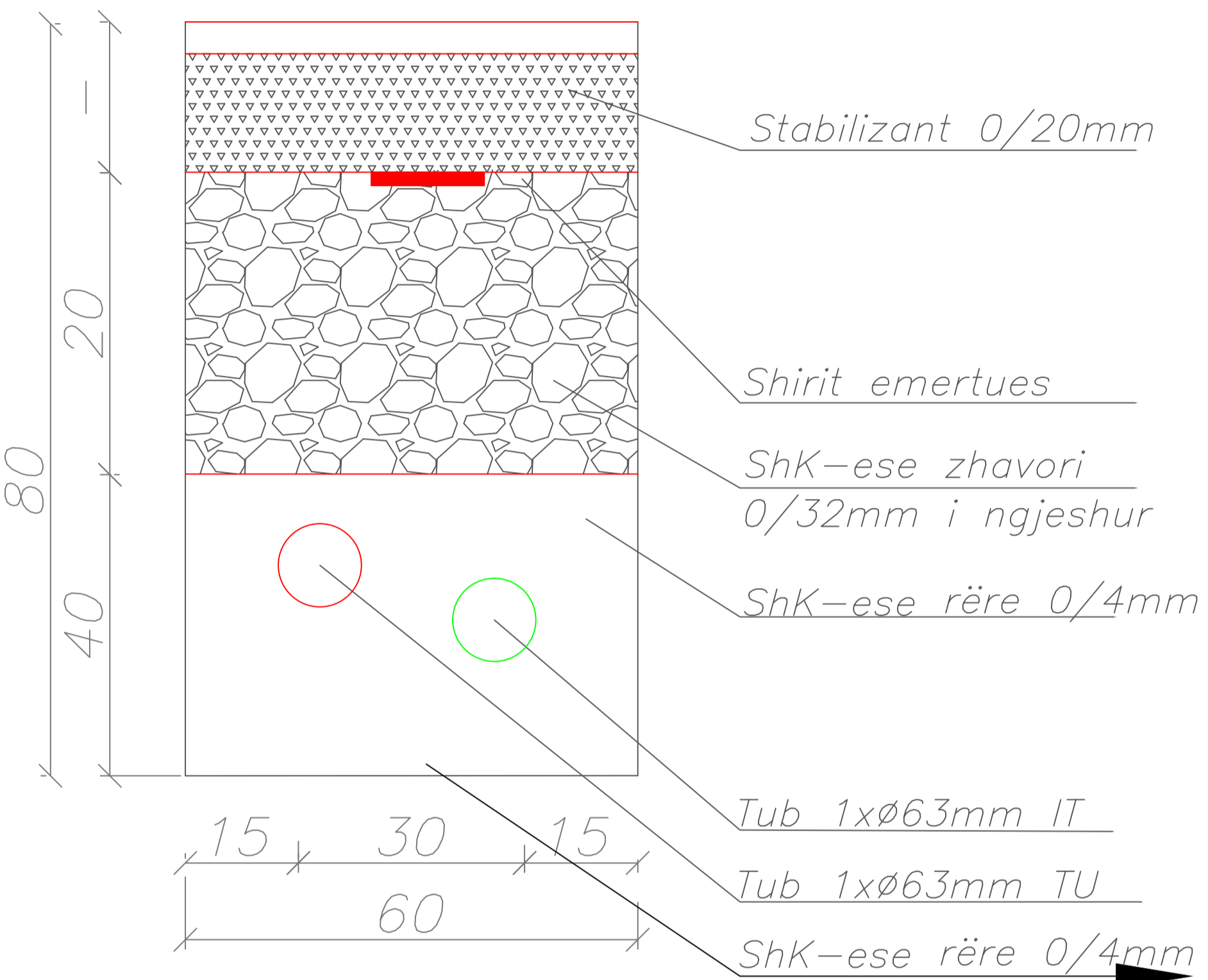

Klienti:
BASHKIA LEZHË

Titulli i Projektit:
NDËRTIMI I RRUGËS SUPERSTRADË - HIDROVOR (TALE)

Faza:
PROJEKT ZBATIMI

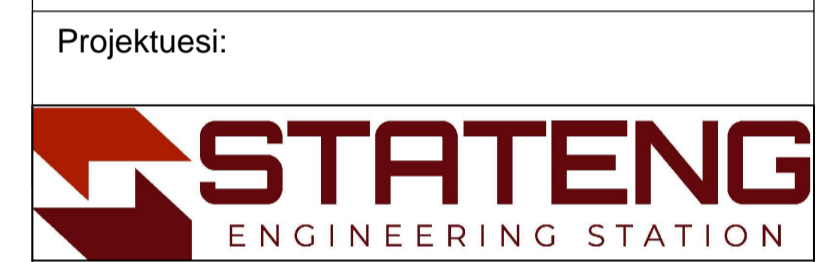

"STATENG" SH.P.K		N. 6965/3
Inxh.Ndërt.	ALTIN SERANAJ	K. 2455/2
Inxh.Ndërt.	ARSELA VOGLI	
Inxh.Elek.	ARJAN SHYTI	E. 1126/3
Inxh.Gjeodet	ERION LAMI	T. 1111/1

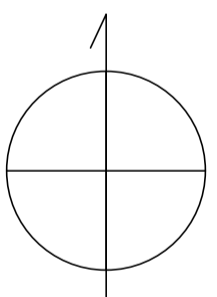

Kapitulli:
PROJEKTI ELEKTRIK

Titulli:
DETAJE TRANSHEVE & PUSHTAVE TE BETONIT

Shkalla:
N/A

Nr :
E-24

Data:
2022

Planimetria e instalimit të rrjetit kabllor të ndriçimit,

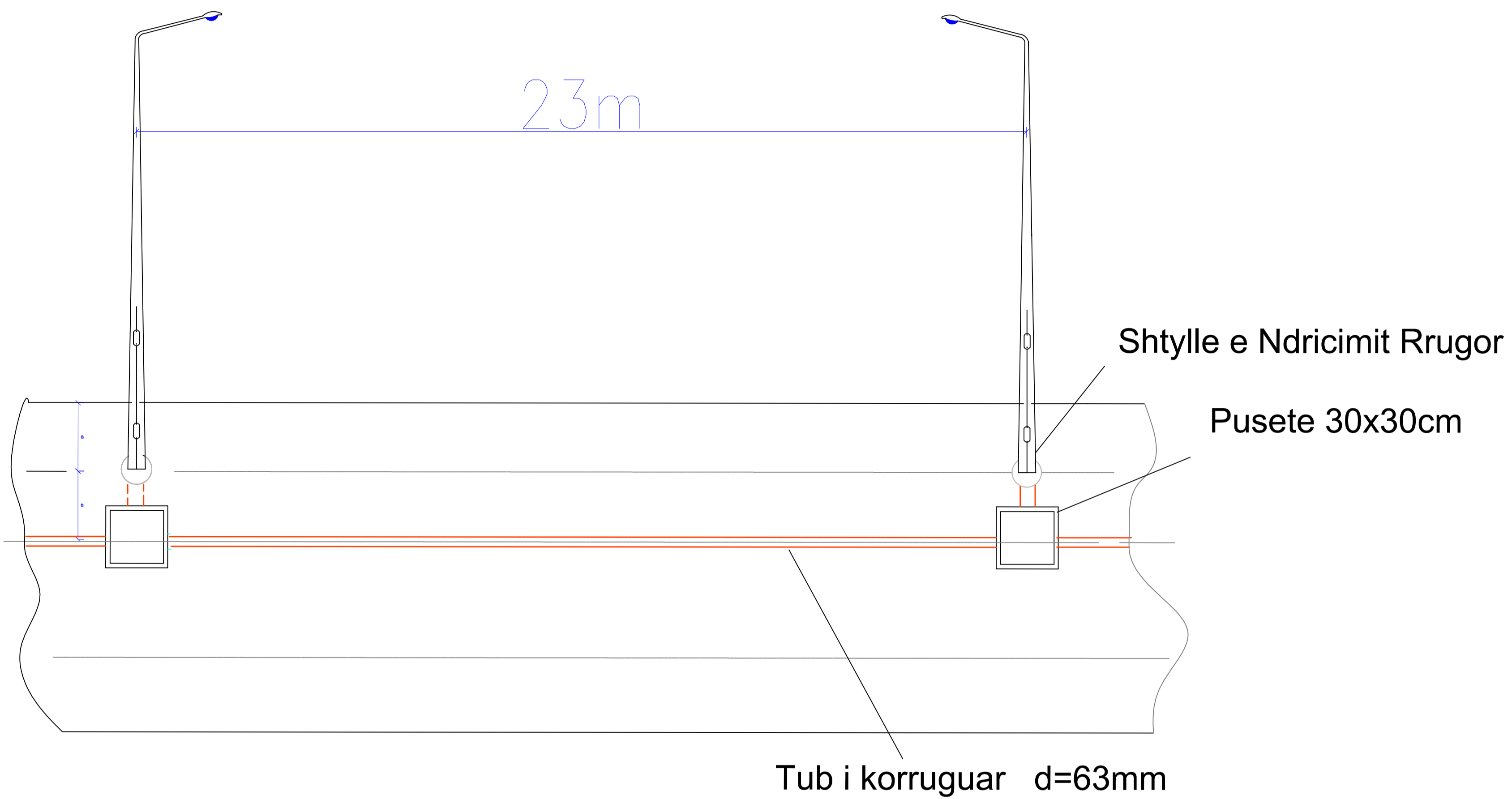

Prerje e vendosjes së pusetave

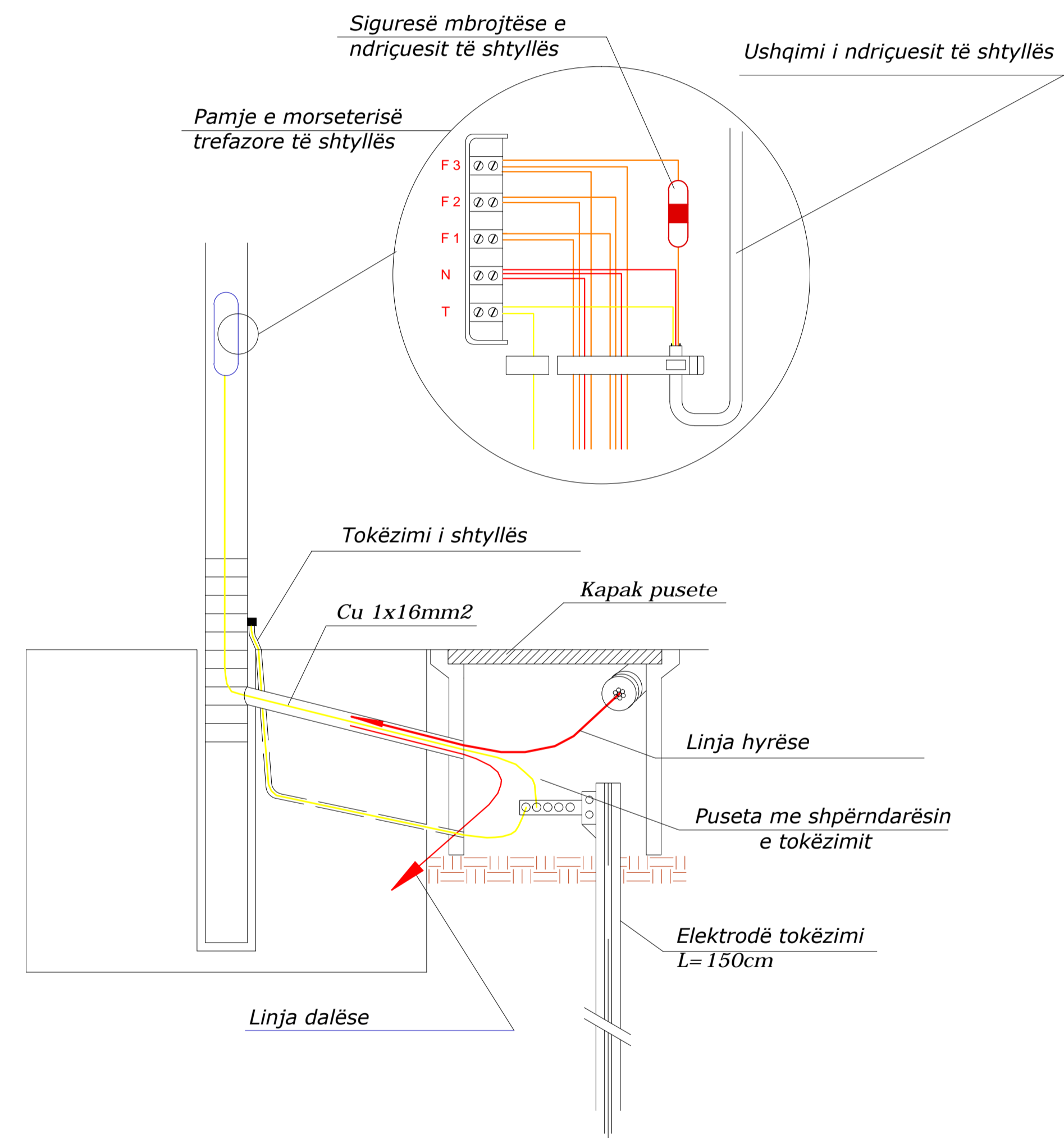
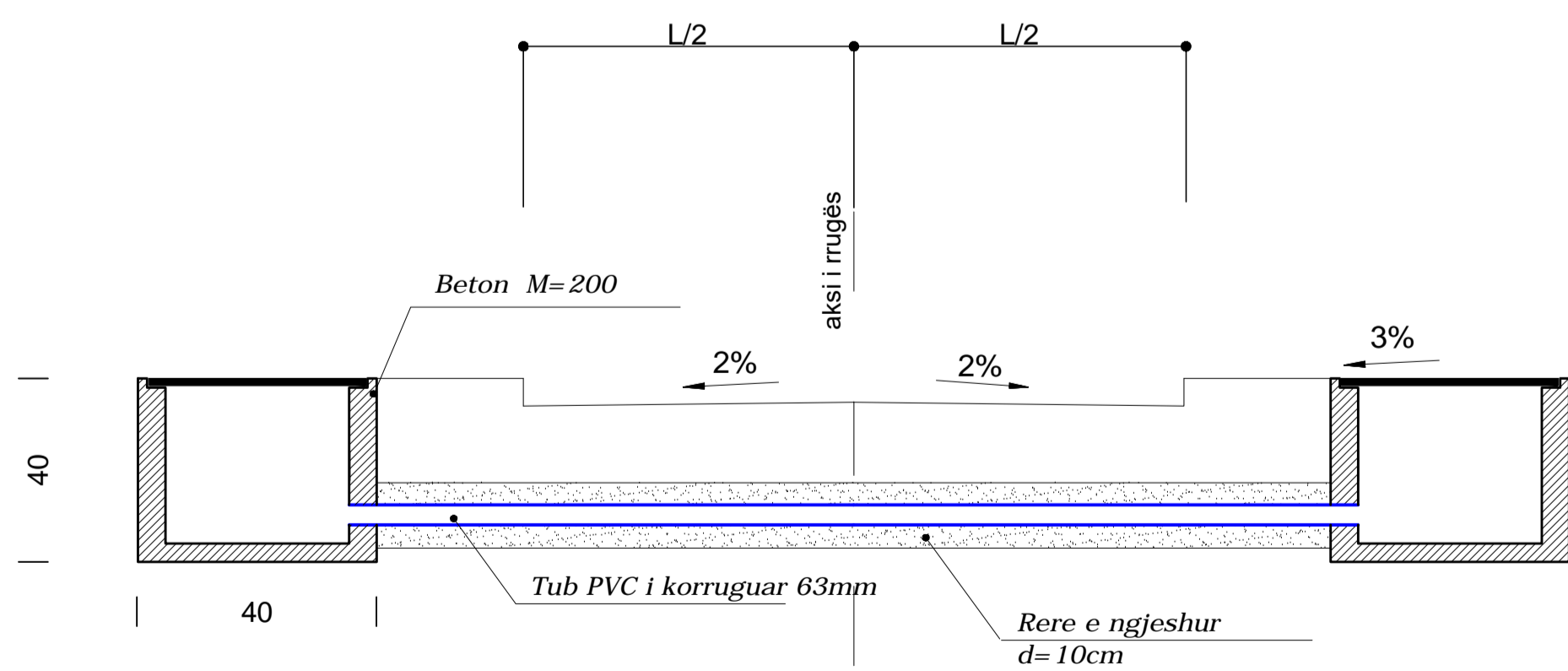

Klienti:

BASHKIA LEZHË

Titulli i Projektit:

**NDËRTIMI I RRUGËS
SUPERSTRADË -
HIDROVOR (TALE)**

Faza:

PROJEKT ZBATIMI

Projektuesi:



"STATENG" SH.P.K N. 6965/3

Inxh.Ndërt. ALTIN SERANAJ K. 2455/2

Inxh.Ndërt. ARSELA VOGLI

Inxh.Elek. ARJAN SHYTI E. 1126/3

Inxh.Gjeodet ERION LAMI T. 1111/1

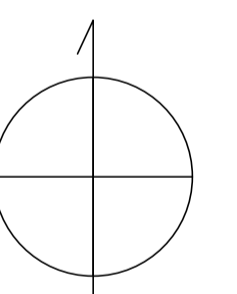

Kapitulli:

PROJEKTI ELEKTRIK

Titulli:

**DETAJ INSTALIMI TE TUBAVE
ELEKTRIK**

Shkalla:

N/A

Nr :

E-25

Data:

2022



Klienti:

BASHKIA LEZHË

Titulli i Projektit:

**NDËRTIMI I RRUGËS
SUPERSTRADË -
HIDROVOR (TALE)**

Faza:

PROJEKT ZBATIMI

Projektuesi:



"STATENG" SH.P.K N. 6965/3

Inxh.Ndërt. ALTIN SERANAJ K. 2455/2

Inxh.Ndërt. ARSELA VOGLI

Inxh.Elek. ARJAN SHYTI E. 1126/3

Inxh.Gjeodet ERION LAMI T. 1111/1

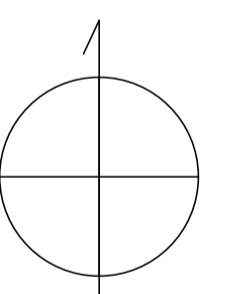

Kapitulli:

PROJEKTI ELEKTRIK

Titulli:

**DETAJ INSTALIMI TE TUBAVE
ELEKTRIK**

Shkalla:

N/A

Nr :

E-26

Data:

2022

HOLLËSI E INKASTRIMIT TË KOLONËS SË NDRIÇUESIT ME LARTESI H=9M

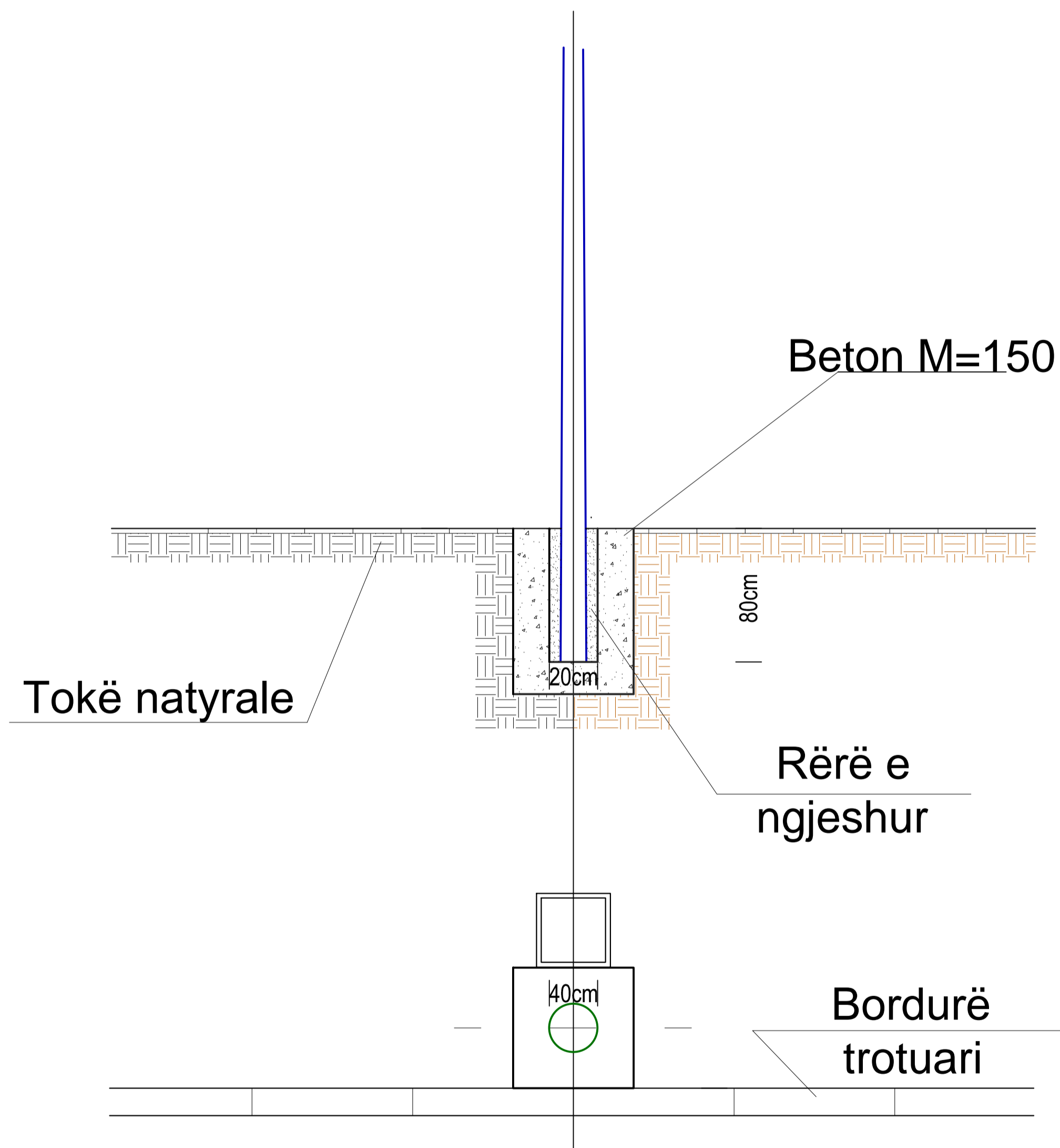

VENDOSJES SË PUSËTËS PËR TUB 63mm

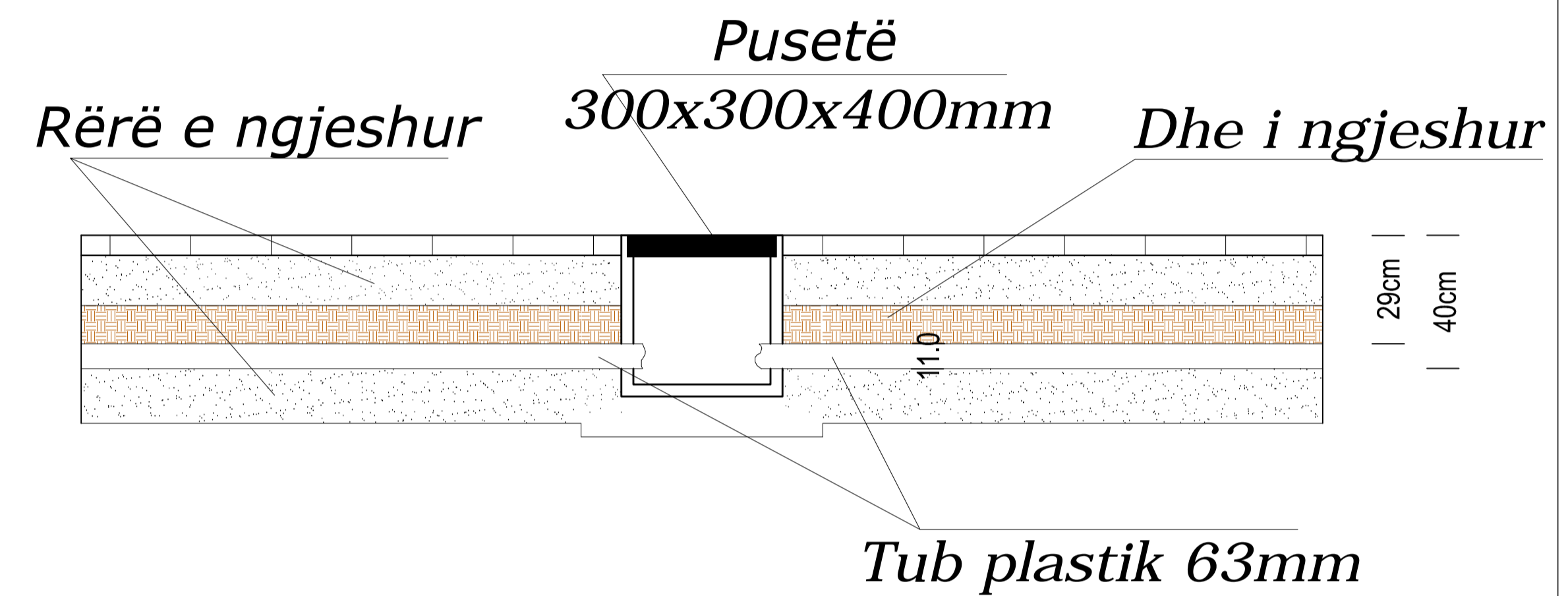



Klienti:

BASHKIA LEZHË

Titulli i Projektit:

**NDËRTIMI I RRUGËS
SUPERSTRADË -
HIDROVOR (TALE)**

Faza:

PROJEKT ZBATIMI

Projektuesi:



"STATENG" SH.P.K N. 6965/3

Inxh.Ndërt. ALTIN SERANAJ K. 2455/2

Inxh.Ndërt. ARSELA VOGLI

Inxh.Elek. ARJAN SHYTI E. 1126/3

Inxh.Gjeodet ERION LAMI T. 1111/1

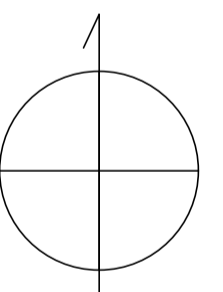

Kapitulli:

PROJEKTI ELEKTRIK

Titulli:

**SKEMA ELEKTRIKE PANELI
KEN-01**

Shkalla:

N/A

Nr :

E-27

Data:

2022

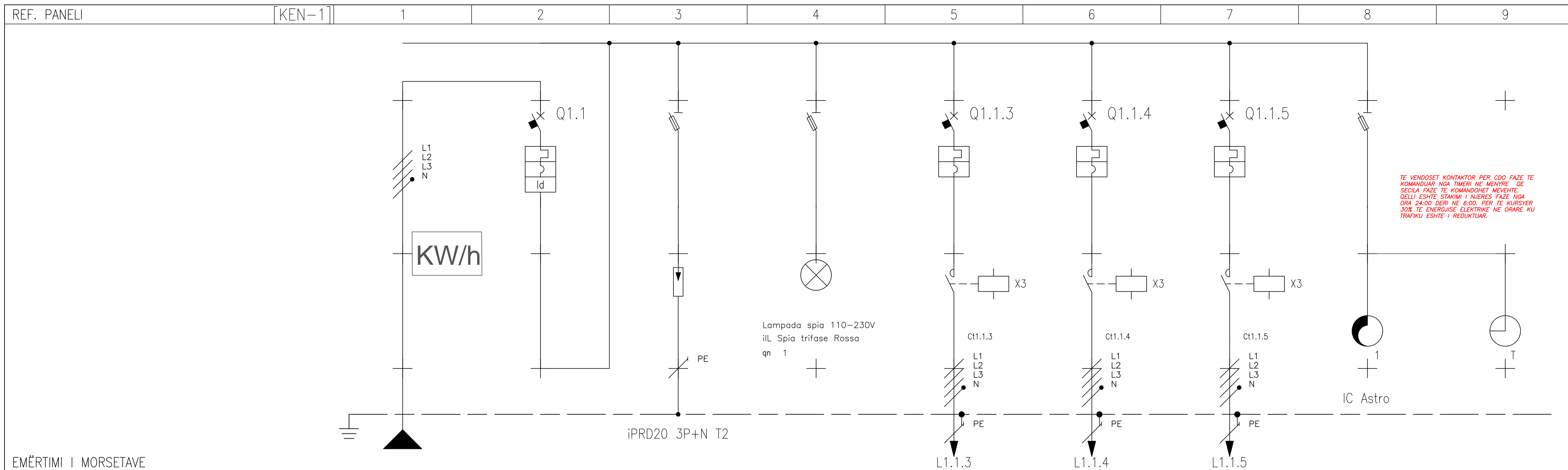

EMËRTIMI I MORSETAVE

EMËRTIMI I QARKUT	SHPËRNDARJA	1	L1L2L3NPE	1	RSTN	2	L1L2L3NPE	3	L1L2L3NPE	4	L1L2L3NPE	5	L1L2L3NPE	6	L1L2L3NPE	7	L1L2L3NPE	8	DISTR
PËRSHKRIMI I QARKUT		1		1		SPD		LLAMPE SINJALI		K-1-L1		K-1-L2		K-1-L3		7		TIMER	
TIPI I APARATUËS				iC40 a	STI	3P+N Fus NFC (8,5x13)		3P+N Fus NFC (10,3x38)		iC40 a		iC40 a		iC40 a		STI		3P+N Fus NFC (10,3x38)	
NDARËSI	Icu [kA]			6						6		6		6					
	N. POLE			3P+N	16					3P+N	16	3P+N	16	3P+N	16				
	KURBA MBROJTESE			C						C		C		C					
	I _r [A]			16						16		16		16					
	I _{sd} [A]			160						160		160		160					
	I _i [A]																		
DIFERENCIALI	TIPI			Vigi	AC														
	I _{dn} [A]			0.03	Istantaneo														
KONTAKTOR TELERUTORI	TIPI									iCT Na	AC7a	iCT Na	AC7a	iCT Na	AC7a				
	BOBINA [V]									230ca	4P	20	230ca	4P	20	230ca	4P	20	
TERMIKE	TIPI																		
SIGURESA	N. POLE																		
TË TJERA AP.	TIPI																		
KABLLAZHI	TIPI I IZOLACIONIT			EPR	13			EPR		EPR	61	EPR	61	EPR	61				
	SEKSIONI FAZA-N-PE/PEN [mmq]			1x16	1x16	1x16				1x16	1x16	1x16	1x4	1x4	1x4	1x16	1x16	1x16	
	I _b [A]			15.7	23			0		5.3	71	3.5	31.5	6.9	71				
	U _n [V]			400	10.32			400	0	400	3.48	400	2.32	400	4.52				
FUNDI I LINJËS	I _{cc min} [kA]			3	5.8			0		0	0.2	0	0.1	0.1	0.2				
	GJATËSIA [m]			1	0.1					1160	3.8	450	3.8	900	3.8				
SHËNIME			FG160R16-0,6/1 kV Cca-s3,d1,a3							FG160R16-0,6/1 kV Cca-s3,d1,a3		FG160R16-0,6/1 kV Cca-s3,d1,a3		FG160R16-0,6/1 kV Cca-s3,d1,a3					

KLIENTI **BASHKIA LEZHË**

OBJEKTI **Ndricimi Rrugor K-1-(L1; L2: L3)
Rruga Rille**

Nr i Vizatimit: **E-27** FILE **KEN-1_[Q01]_[KEN-1].dwg**

LICENCË: **E.1126/3** DATA **3/5/2022** REVIZIONI **0**

PROJEKTUES: **ING. ARJAN SHYTI** FAQA **3** FAQA PASUESE

FIRMA



Klienti:

BASHKIA LEZHË

Titulli i Projektit:

**NDËRTIMI I RRUGËS
SUPERSTRADË -
HIDROVOR (TALE)**

Faza:

PROJEKT ZBATIMI

Projektuesi:



"STATENG" SH.P.K N. 6965/3

Inxh.Ndërt. ALTIN SERANAJ K. 2455/2

Inxh.Ndërt. ARSELA VOGLI

Inxh.Elek. ARJAN SHYTI E. 1126/3

Inxh.Gjeodet ERION LAMI T. 1111/1

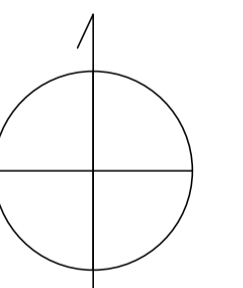

Kapitulli:

PROJEKTI ELEKTRIK

Titulli:

**SKEMA ELEKTRIKE PANELI
KEN-02**

Shkalla:

N/A

Nr :

E-28

Data:

2022

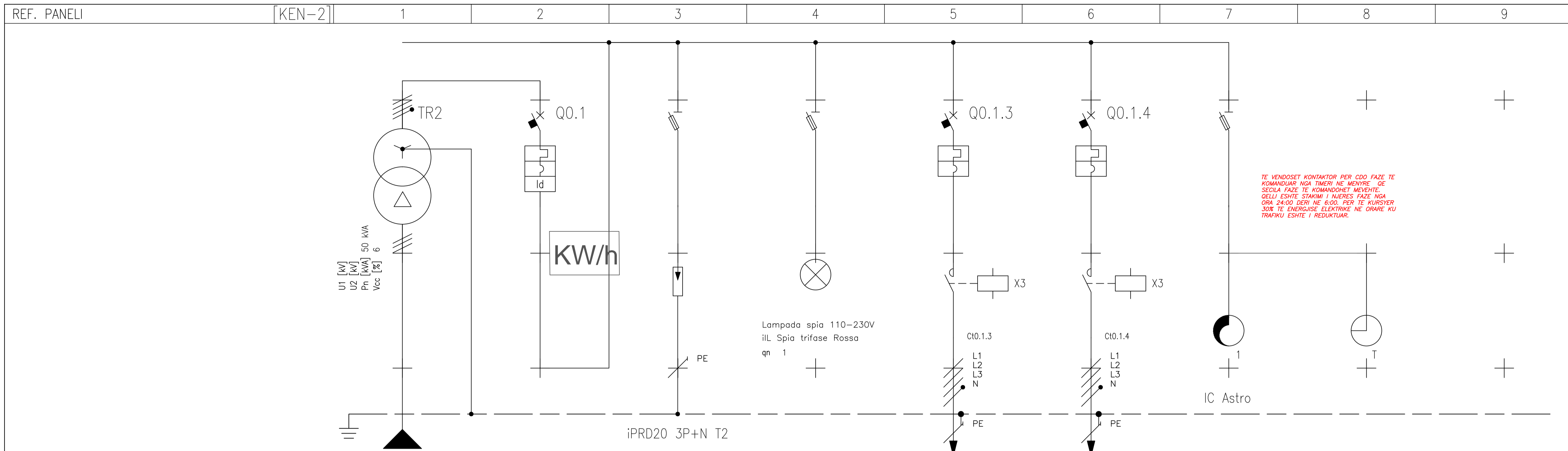

EMËRTIMI I MORSETAVE

EMËRTIMI I QARKUT	SHPËRNDARJA	L1L2L3NPE	1	RSTN	2	L1L2L3NPE	3	L1L2L3NPE	4	L1L2L3NPE	5	L1L2L3NPE	6	L1L2L3NPE	8	
PËRSHKRIMI I QARKUT		1	1	SPD	LLAMPE SINJALI	K-2-L1	K-2-L2	RELE KREPUSKULARE	TIMER							
TIPI I APARATUËS			NSX250 B STI	3P+N Fus NFC (8,5x31,38)	3P+N Fus NFC (10,3x38)	iC40 a	iC40 a	STI	3P+N Fus NFC (10,3x38)							
NDARËSI	Icu [kA]		25			6	6									
	N. POLE	In [A]	4P	40		3P+N	16	3P+N	16							
	KURBA MBROJTESE		MicroL4.2 Vigi				C	C								
	I _r [A]	t _r [s]	16.2	0.9x			16	16								
	I _{sd} [A]	t _{sd} [s]	162	10x			160	160								
	I _l [A]															
DIFERENCIALI	TIPI	KLASI	Micrologic Vigi	A												
	I _{dn} [A]	t _{dn} [ms]	0.03	0												
KONTAKTOR TELERUTORI	TIPI	KLASI				iCT Na	AC7a	iCT Na	AC7a							
	BOBINA [V]	N. POLE	In [A]			230ca	4P	20	230ca	4P	20					
TERMIKE	TIPI	I _{rth} [A]														
SIGURESA	N. POLE	In [A]														
TË TJERA AP.	TIPI															
KABLLAZHI	TIPI I IZOLACIONIT	INSTALIMI	EPR	13		EPR	EPR	61	EPR	61						
	SEKSIONI FAZA-N-PE/PEN [mmq]		1x25	1x25	1x25				1x16	1x16	1x16	1x16	1x16	1x16		
	I _b [A]	I _z [A]	14	246					7	71	6.9	71				
	U _n [V]	P _n [kW]	400		9.16				400	4.64	400	4.52				
FUNDI I LINJËS	I _{cc min} [kA]	I _{cc max} [kA]	3.4	4.2					0.1	0.2	0	0.2				
	GJATËSIA [m]	dV TOTALE [%]	1	0					910	3.8	965	4				
SHËNIME			FG160R16-0,6/1 kV						FG160R16-0,6/1 kV		FG160R16-0,6/1 kV					
			Cca-s3,d1,a3						Cca-s3,d1,a3		Cca-s3,d1,a3					

KLIENTI **BASHKIA LEZHË**

Nr i Vizatimit: E-28 FILE ken-2_[Q00]_[KEN-2].dwg

LICENCË: E.1126/3 DATA 3/5/2022 REVIZIONI 0

PROJEKTUES: ING. ARJAN SHYTI FAQA 3 FAQA PASUESE

OBJEKTI **Ndricimi Rrugor K-2-(L1; L2)
Rruga Rille**

FIRMA



Klienti:

BASHKIA LEZHË

Titulli i Projektit:

**NDËRTIMI I RRUGËS
SUPERSTRADË -
HIDROVOR (TALE)**

Faza:

PROJEKT ZBATIMI

Projektuesi:



"STATENG" SH.P.K N. 6965/3

Inxh.Ndërt. ALTIN SERANAJ K. 2455/2

Inxh.Ndërt. ARSELA VOGLI

Inxh.Elek. ARJAN SHYTI E. 1126/3

Inxh.Gjeodet ERION LAMI T. 1111/1

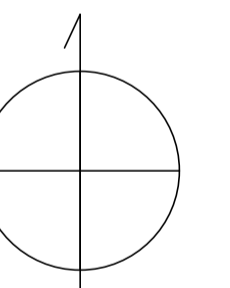

Kapitulli:

PROJEKTI ELEKTRIK

Titulli:

**SKEMA ELEKTRIKE PANELI
KEN-03**

Shkalla:

N/A

Nr :

E-29

Data:

2022

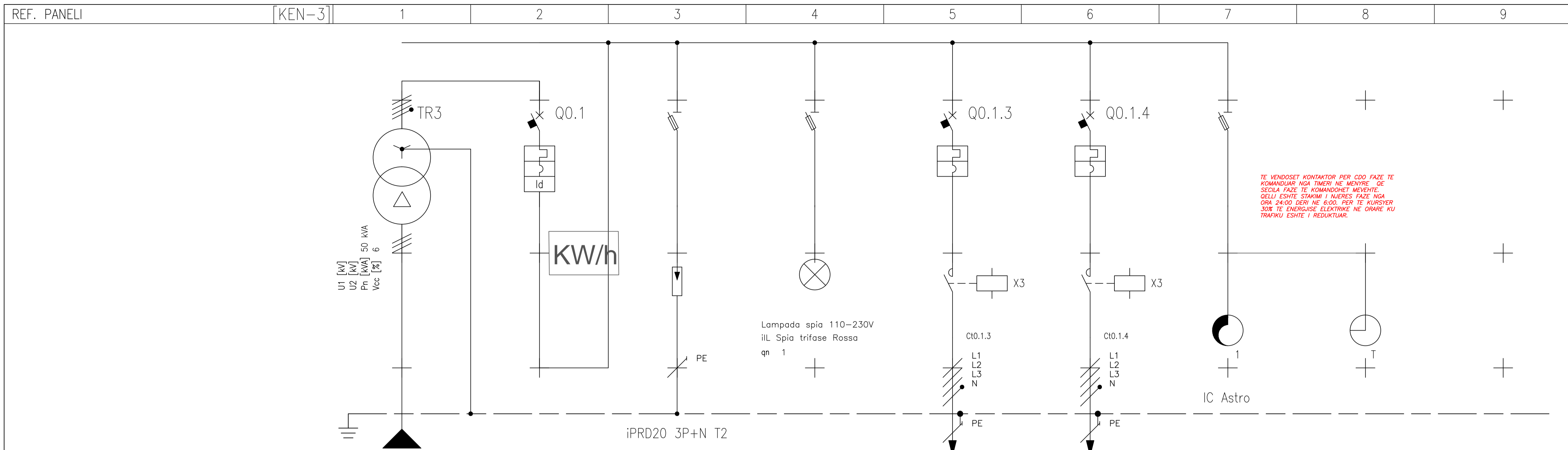

TE VENDOSJET KONTAKTOR PER CDO FAZE TE
KOMANDUAR NGA TIMERI NE MENYRE QE
SECIJA FAZE TE KOMANDOHET MEVEHTE
QELLI ESHTE STAKIM I NJERES FAZE NGA
ORA 24:00 DERI NE 6:00. PER TE KURSYER
JOS TE ENERJISE ELEKTRIKE NE ORARE KU
TRAFIKU ESHTE I REDUKTUAR.

EMËRTIMI I MORSETAVE		EMËRTIMI I QARKUT		SHPËRNDARJA		L1L2L3NPE		1		RSTN		2		L1L2L3NPE		3		L1L2L3NPE		4		L1L2L3NPE		5		L1L2L3NPE		6		L1L2L3NPE		8				
PËRSHKRIMI I QARKUT		1		1		SPD		LLAMPE SINJALI		K-3-L1		K-3-L2		RELE KREPUSKULARE		TIMER																				
TIPI I APARATUËS		NSX250 B STI		3P+N Fus NFC (8,5x31,5)		3P+N Fus NFC (10,3x38)		iC40 a		iC40 a		STI		3P+N Fus NFC (10,3x38)																						
NDARËSI	Icu [kA]	25						6		6																										
	N. POLE	In [A]	4P	40					3P+N	16	3P+N	16																								
	KURBA MBROJTESE		MicroL4.2 Vigi						C		C																									
	Ir [A]	tr [s]	16.2	0.9x					16		16																									
	I _{sd} [A]	tsd [s]	162	10x					160		160																									
	Ii [A]																																			
DIFERENCIALI	TIPI	KLASI	Micrologic Vigi A																																	
	I _{dn} [A]	t _{dn} [ms]	0.03	0																																
KONTAKTOR TELERUTORI	TIPI	KLASI							iCT Na AC7a		iCT Na AC7a																									
	BOBINA [V]	N. POLE	In [A]						230ca	4P	20	230ca	4P	20																						
TERMIKE	TIPI	I _{rth} [A]																																		
SIGURESA	N. POLE	In [A]																																		
TË TJERA AP.	TIPI																																			
KABLLAZHI	TIPI I IZOLACIONIT	INSTALIMI	EPR	13					EPR		EPR		EPR		EPR																					
	SEKSIONI FAZA-N-PE/PEN [mmq]	1x25	1x25	1x25							1x16		1x16		1x16		1x16		1x16		1x16		1x16													
	I _b [A]	I _z [A]	14.2	246					0		7		71		7		71																			
	Un [V]	P _n [kW]	400		9.28			400		0		400		4.64		400		4.64																		
FUNDI I LINJËS	I _{cc min} [kA]	I _{cc max} [kA]	3.4	4.2					0		0.2		0		0.2																					
	GJATËSIA [m]	dV TOTALE [%]	1	0					935		4		935		4																					
SHËNIME	FG160R16-0,6/1 kV Cca-s3,d1,a3								FG160R16-0,6/1 kV Cca-s3,d1,a3		FG160R16-0,6/1 kV Cca-s3,d1,a3																									

-	-	-	-	KLIENTI	BASHKIA LEZHË	Nr i Vizatimit:	E-29	FILE	KEN-3_[Q00]_[KEN-3].dwg		
				OBJEKTI	Ndricimi Rrugor K-3-(L1; L2) Rruga Rille	LICENCË:	E.1126/3	DATA	3/5/2022	REVIZIONI	0
						PROJEKTUES:	ING. ARJAN SHYTI	FAQA	3	FAQA PASUESE	



Klienti:

BASHKIA LEZHË

Titulli i Projektit:

**NDËRTIMI I RRUGËS
SUPERSTRADË -
HIDROVOR (TALE)**

Faza:

PROJEKT ZBATIMI

Projektuesi:



"STATENG" SH.P.K N. 6965/3

Inxh.Ndërt. ALTIN SERANAJ K. 2455/2

Inxh.Ndërt. ARSELA VOGLI

Inxh.Elek. ARJAN SHYTI E. 1126/3

Inxh.Gjeodet ERION LAMI T. 1111/1

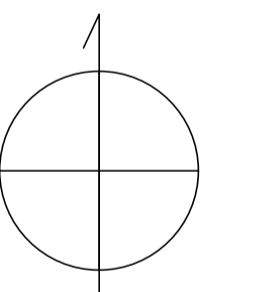

Kapitulli:

PROJEKTI ELEKTRIK

Titulli:

**SKEMA ELEKTRIKE PANELI
KEN-04**

Shkalla:

N/A

Nr :

E-30

Data:

2022

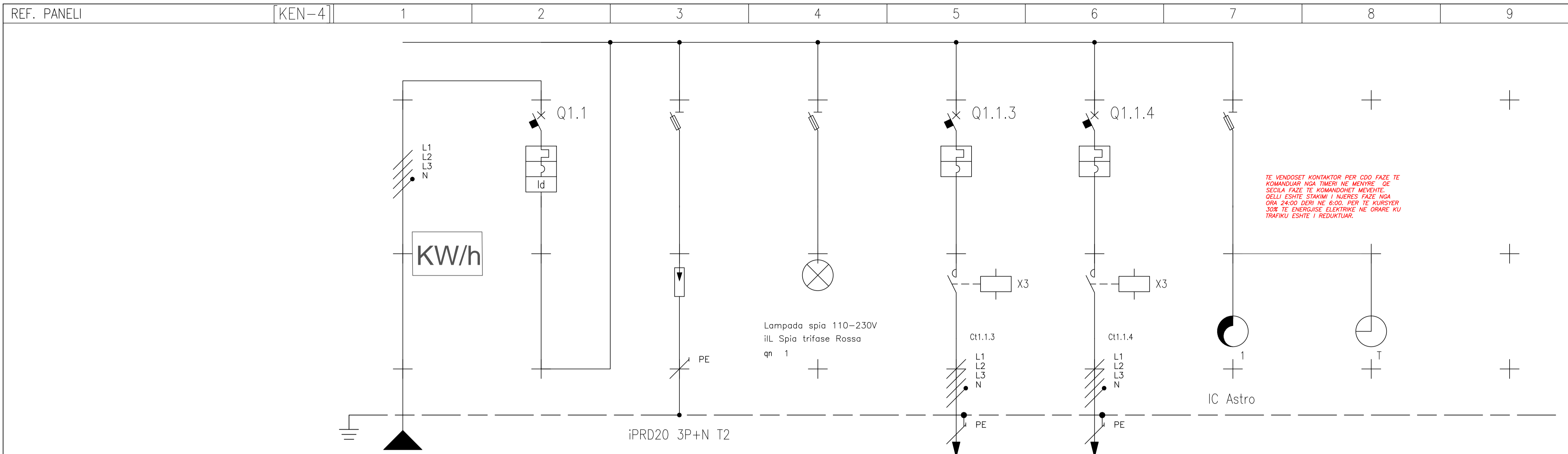

EMËRTIMI I MORSETAVE		EMËRTIMI I QARKUT		SHPËRNDARJA		L1L2L3NPE		1		RSTN		2		L1L2L3NPE		3		L1L2L3NPE		4		L1L2L3NPE		5		L1L2L3NPE		6		L1L2L3NPE		8			
PËRSHKRIMI I QARKUT		1		1		SPD		LLAMPE SINJALI		K-4-L1		K-4-L2		6		TIMER																			
TIPI I APARATUËS		iC40 a		STI		3P+N Fus NFC (8,5x13)		3P+N Fus NFC (10,3x38)		iC40 a		iC40 a		STI		3P+N Fus NFC (10,3x38)																			
NDARËSI	Icu [kA]	6								6		6																							
	N. POLE	In [A]	3P+N		10						3P+N		16		3P+N		16																		
	KURBA MBROJTESE		C								C		C																						
	Ir [A]	tr [s]	10								16		16																						
	I _{sd} [A]	tsd [s]	100								160		160																						
	I _{li} [A]																																		
DIFERENCIALI	TIPI	KLASI		Vigi		AC																													
	I _{dn} [A]	tdn [ms]		0.03		Istantaneo																													
KONTAKTOR TELERUTORI	TIPI	KLASI								iCT Na		AC7a		iCT Na		AC7a																			
	BOBINA [V]	N. POLE	In [A]							230ca		4P		20		230ca		4P		20															
TERMIKE	TIPI	I _{rth} [A]																																	
SIGURESA	N. POLE	In [A]																																	
TË TJERA AP.	TIPI																																		
KABLLAZHI	TIPI I IZOLACIONIT	INSTALIMI		EPR		13				EPR		EPR		61		EPR		61																	
	SEKSIONI FAZA-N-PE/PEN [mmq]	1x16	1x16	1x16							1x10		1x10	1x10	1x6	1x6	1x6																		
	I _b [A]	I _z [A]		8.3		23				0		4.4		54.2		3.9		40.4																	
	U _n [V]	P _n [kW]		400		5.45		5.45		400		0		400		2.9		400		2.55															
FUNDI I LINJËS	I _{cc min} [kA]	I _{cc max} [kA]		3		5.8				0		0.2		0		0.2																			
	GJATËSIA [m]	dV TOTALE [%]		1		0.1				620		2.6		540		3.3																			
SHËNIME			FG160R16-0,6/1 kV		Cca-s3,d1,a3						FG160R16-0,6/1 kV		Cca-s3,d1,a3		FG160R16-0,6/1 kV		Cca-s3,d1,a3																		

-	KLIENTI	BASHKIA LEZHË	Nr i Vizatimit:	E-30	FILE	KEN-4_[Q01]_[KEN-4].dwg
	-	-	LICENCË:	E.1126/3	DATA	3/5/2022
	-	OBJEKTI	Ndricimi Rrugor K-4-(L1; L2) Rruga Rille	PROJEKTUES:	ING. ARJAN SHYTI	FAQA
-					FIRMA	



Klienti:

BASHKIA LEZHË

Titulli i Projektit:

**NDËRTIMI I RRUGËS
SUPERSTRADË -
HIDROVOR (TALE)**

Faza:

PROJEKT ZBATIMI

Projektuesi:



"STATENG" SH.P.K N. 6965/3

Inxh.Ndërt. ALTIN SERANAJ K. 2455/2

Inxh.Ndërt. ARSELA VOGLI

Inxh.Elek. ARJAN SHYTI E. 1126/3

Inxh.Gjeodet ERION LAMI T. 1111/1

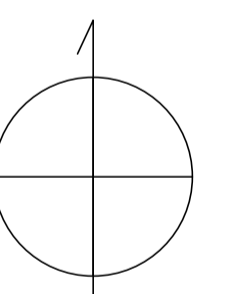

Kapitulli:

PROJEKTI ELEKTRIK

Titulli:

**KABINA ELEKTRIKE 2 & 3
(KABINA TE REJA 50KVA)**

Shkalla:

N/A

Nr :

E-31

Data:

2022

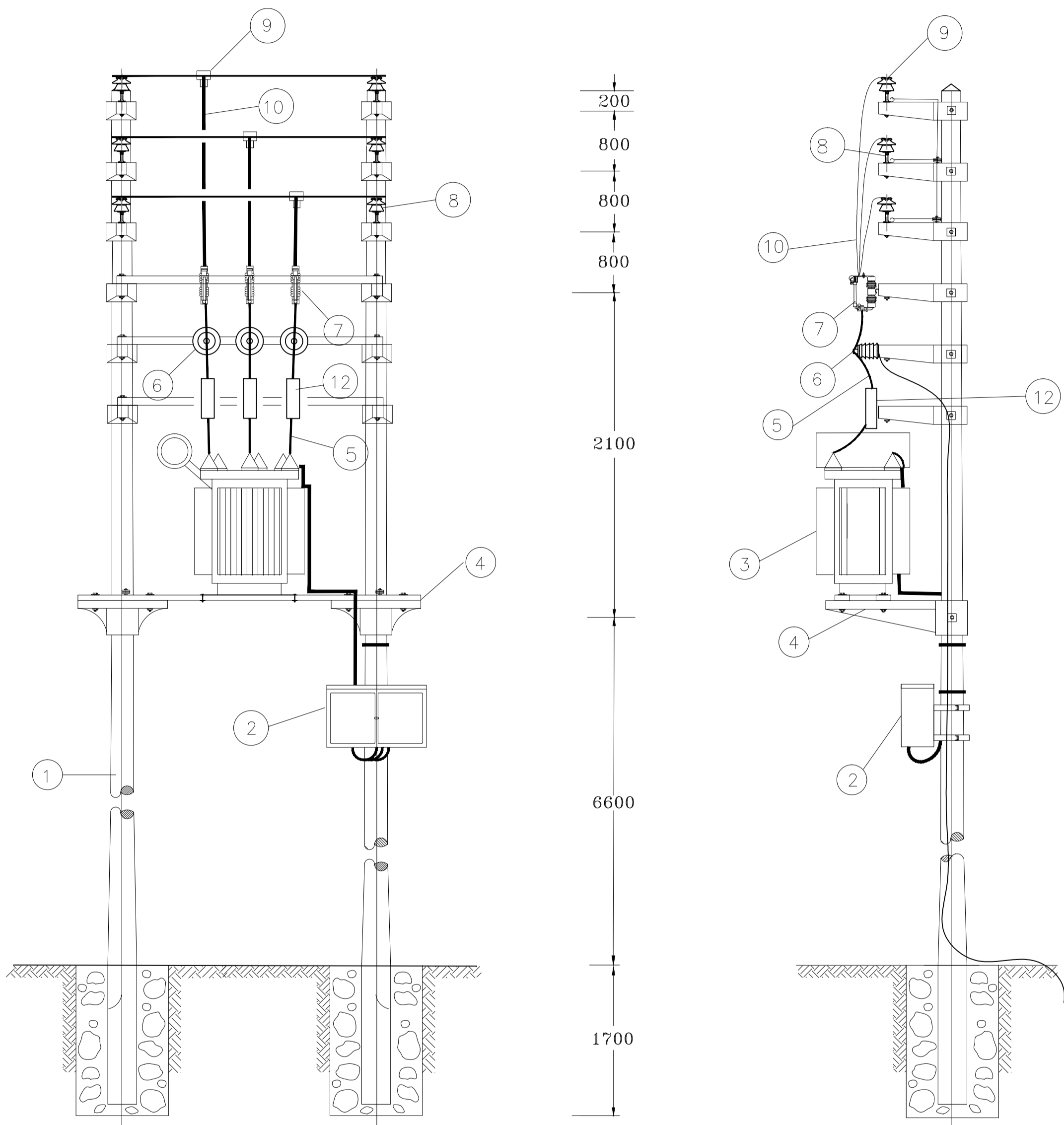

PAMJE BALLORE

MBROJTJA NGA MBITENSIONET		
TIP	11KV, 10 KA	SHKARKUES

PAMJE ANESORE

1	SHTYLLE BETONI CENTIFUGALE 12/300 H=12m MARKA E BETONIT C300
2	PANEL TENSIONI I ULET (PE-TU) I RI
3	TRANSFORMATOR 10/0.4kv ME FTOHJE NATYRALE ME VAJ
4	TRANVERS METALIKE
5	PERCJELLES BAKRI 240mm ²
6	SHKARKUES MBITENSIONI
7	THIKE NDARSE TM
8	IZOLATOR TM 6.3kv
9	MORSETA ALUMINI
10	PERCJELLES ALUMINI
11	MORSETA ALUMINI
12	SIGURESA TM BOG 25A

BETONIMI I SHTYLLAVE TE BETONIT (SHTYLL H=12 m)

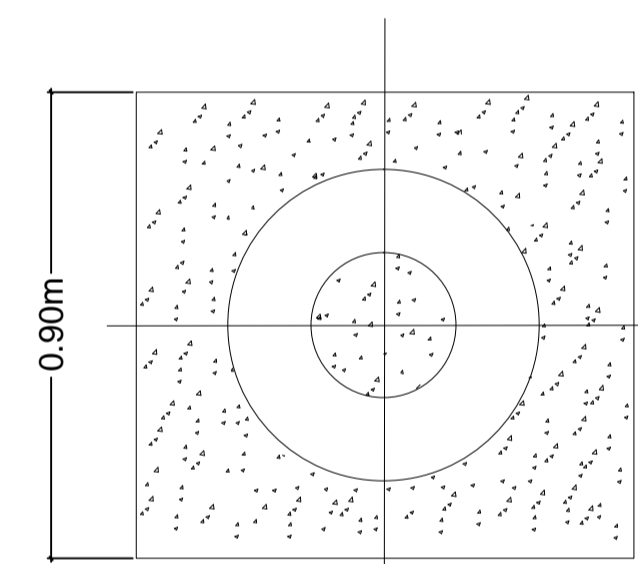
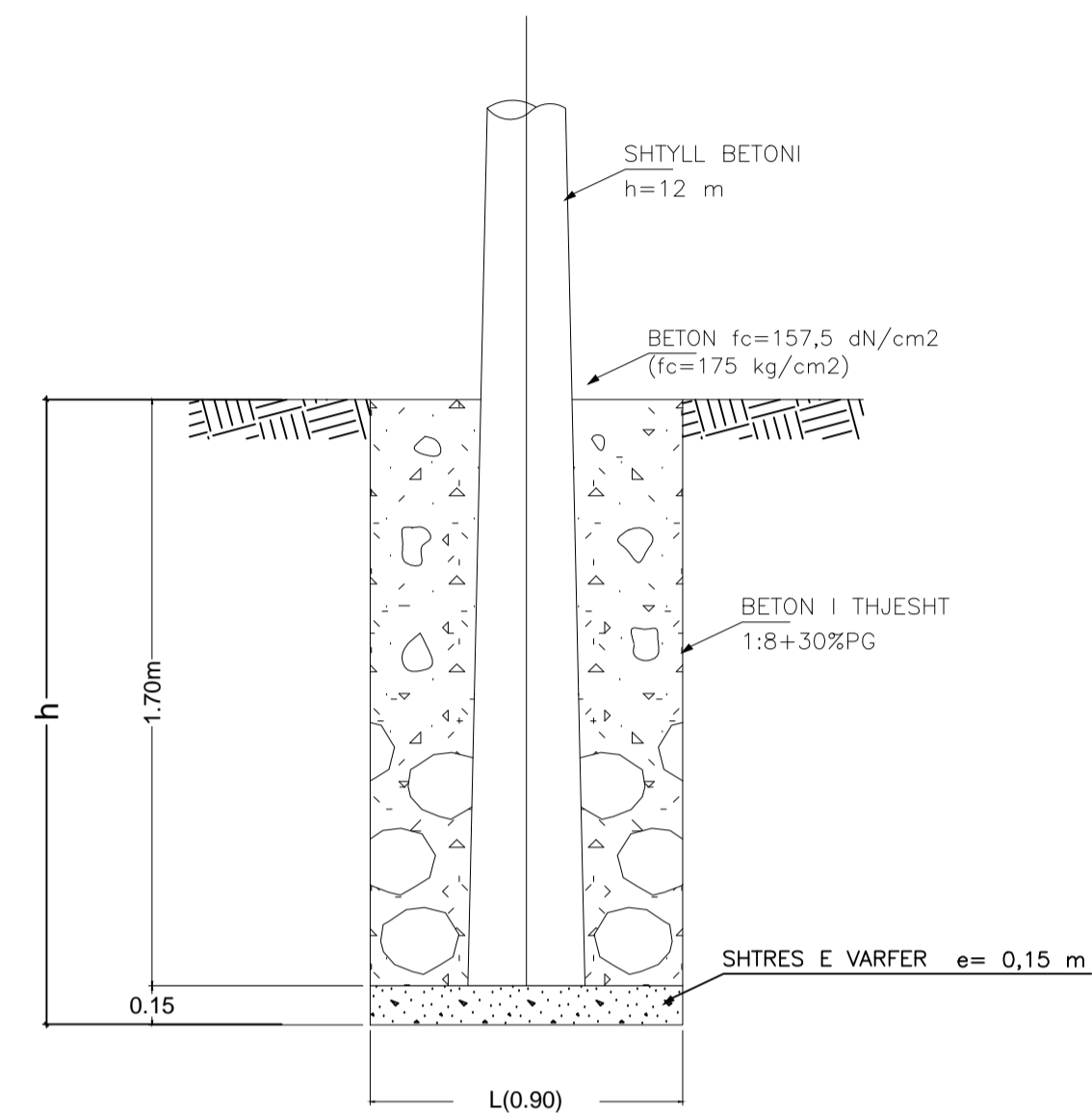

SHTYLLA BETONI NE TOKE TIP CM-I

SHTYLLA	GJERESI (L)	THELL (h) m	GERMIM m ³	MBUSHJE (m ³)
12/200				
12/300	0,90	1,85	1,50	1,24
12/400				

TUPI I TERENIT
- TOKE ARGJILOSE KONGLOMERATE

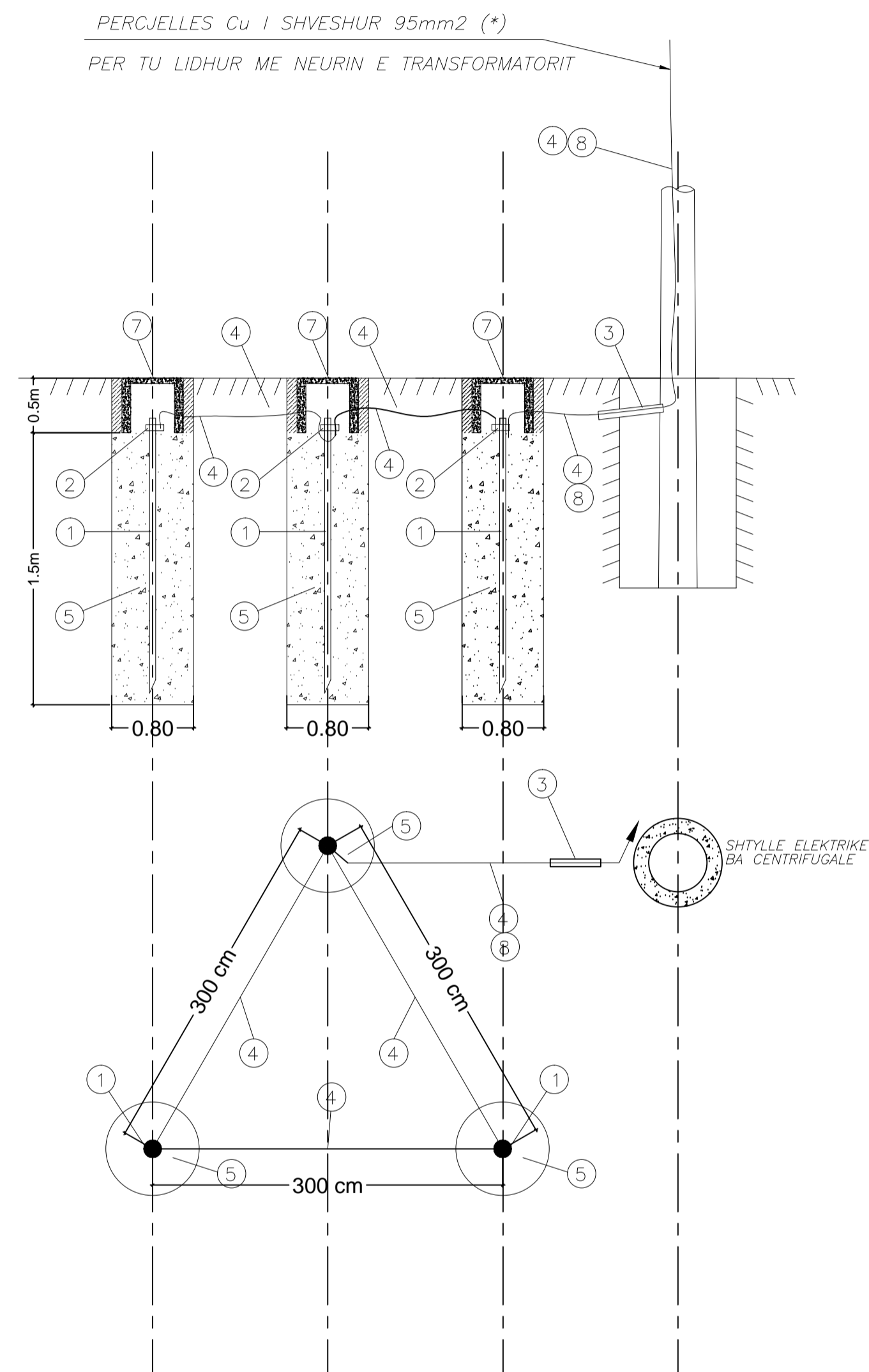

8	KABELL HD7-VK 95 mm ²
7	KAPAK PUSETE TOKEZIMI 500X500X450 mm,
6	KONEKTOR Cu (SPLIT BOLT) TIP PERNO PER LIDHJE TE PERCJELLSIT Cu 95mm ²
5	TOKE E HEDHUR (m ³)
4	PERCJELLES Cu I SHVESHUR 95mm ² (*)
3	TUBO PVC 32ø (mm)
2	MORSET METALIKE E ZINKUAR PER LIDHJE TE ELEKTRODES ME RRJETIN E TOKEZIMIT
1	ELEKTROD TOKEZIMI E ZINKUAR 1,5m