



















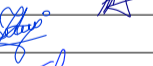

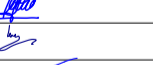

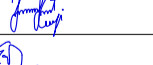

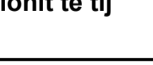
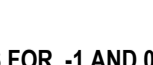
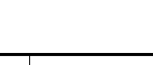
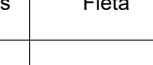
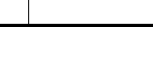

Kati -1

### Legjenda/Legend

-  Kanalina metalike për rrjetin e fuqisë, gjëresi 20 cm/Metallic cable tray, 20 cm width for power system network
-  Brryl 90 ° për kanalina me gjëresi 20 cm për rrjetin e fuqisë/Elbow with 90 ° for cable tray with 20 cm width for power system network
-  Degëzim për kanalina me gjëresi 20 cm për rrjetin e fuqisë/Branch for cable tray with 20 cm width for power system network
-  Kryqëzim për kanalina me gjëresi 20 cm për rrjetin e fuqisë/Junction for cable tray with 20 cm width for power system network
-  Kanalina metalike për rrjetin e sinjaleve, gjëresi 10 cm/Metallic cable tray, 10 cm width for data system network
-  Brryl 90 ° për kanalina me gjëresi 10 cm për rrjetin e sinjaleve/ Elbow with 90 ° for cable tray with 10 cm width for data system network
-  Degëzim për kanalina me gjëresi 10 cm për rrjetin e sinjaleve/Branch for cable tray with 10 cm width for data system network
-  Kryqëzim për kanalina me gjëresi 10 cm për rrjetin e sinjaleve/Junction for cable tray with 10 cm width for data system network

00		Tetor 2024		Projekt Lejë	
RISH. NR.	DATA	QËLLIMI I DORËZIMIT	SHENIM / PËRSHKRIM		
 <b>FONDI SHOIPTAR I ZHVILLIMIT</b>					
<b>KONSULENTI INXHINIERIK</b> Nr. Licencës: N.5221/16  <b>ICE</b> ILLYRIAN CONSULTING ENGINEERS Adresa: Rr. "Sami Frashëri", Pallat "Hogos", Katë 11, Tiranë, SHQIPËRI Telefoni: +355 4 200 972, E-mail: info@ice.al www.ice.al					
Përgatiti:	Pozicioni	Emri	Nr. Licencës	Firma	
	Arkitekt	Edmond MANAHASA	A.0903/2		
	Ing. Strukturist	Anila SPAHIU	K.1068/4		
	Ing. Strukturist	Aida VOKA	K.1340/2		
	Ing. Hidroteknik	Artjola ZOTAJ	K.3443		
	Ing. Hidroteknik	Silvia GJONAJ			
	Ing. Hidroteknik	Anzhela BICI	K.3452		
	Ing. Elektrik	Enis HAVERIKU	E.1450		
	Ing. Elektrik	Ilber PUCI			
	Ing. Mekanik	Marsel PYLLA	M.1288/1		
Kontrolloi:	Ing. Mekanik	Besnik KARAJ	M.0256/2		
	Koordinator Projekti	Abdurrahman SPAHIU	K.1571/5		
	Ing. Strukturist	Taulant KARRIQI	K.1547/6		
	Ing. Elektrik	Emira BERISHA	E.0550/4		
Miratoi:	Drejues Projekti	Olset HAXHIU	K.1619/5		
<b>TITULLI I PROJEKTIT</b> <b>INVESTIME PILOT PËR TRANSFORMIMIN E INFRASTRUKTURËS SË SHËRBBIMEVE DHE RRTJES SË STANDARDIT TË JETËS NË KOMUNITET</b> <b>Objekti: Ndërrhyrje për rikonstrukcionin e spitalit të Peqinit dhe ndryshim i pjesshëm i funksionit të tij</b>					
<b>EMRI I DOKUMENTIT</b> <b>PLANVENDOSJA E KANALINAVE ELEKTRIKE NË KATIN -1 DHE 0 / PLANVIEW OF ELECTRICAL CABLE TRAYS FOR -1 AND 0 FLOOR</b>					
FAZA E PROJEKTIT					
PROJEKT LEJE	Nr. i Dokumentit	Shkalla	Rishikimi	Përmasa e fletës	Fleta
	E-01	1:150	00	A1 (841x594mm)	1/15

## Legjenda/Legend

-  Kanalina metalike për rrjetin e fuqisë, gjërësi 20 cm/Metallic cable tray, 20 cm width for power system network
-  Bryll 90 ° për kanalina me gjërësi 20 cm për rrjetin e fuqisë/Elbow with 90 ° for cable tray with 20 cm width for power system network
-  Degëzim për kanalina me gjërësi 20 cm për rrjetin e fuqisë/Branch for cable tray with 20 cm width for power system network
-  Kryqëzim për kanalina me gjërësi 20 cm për rrjetin e fuqisë/Junction for cable tray with 20 cm width for power system network
-  Kanalina metalike për rrjetin e sinjaleve, gjërësi 10 cm/Metallic cable tray, 10 cm width for data system network
-  Bryll 90 ° për kanalina me gjërësi 10 cm për rrjetin e sinjaleve/ Elbow with 90 ° for cable tray with 10 cm width for data system network
-  Degëzim për kanalina me gjërësi 10 cm për rrjetin e sinjaleve/Branch for cable tray with 10 cm width for data system network
-  Kryqëzim për kanalina me gjërësi 10 cm për rrjetin e sinjaleve/Junction for cable tray with 10 cm width for data system network

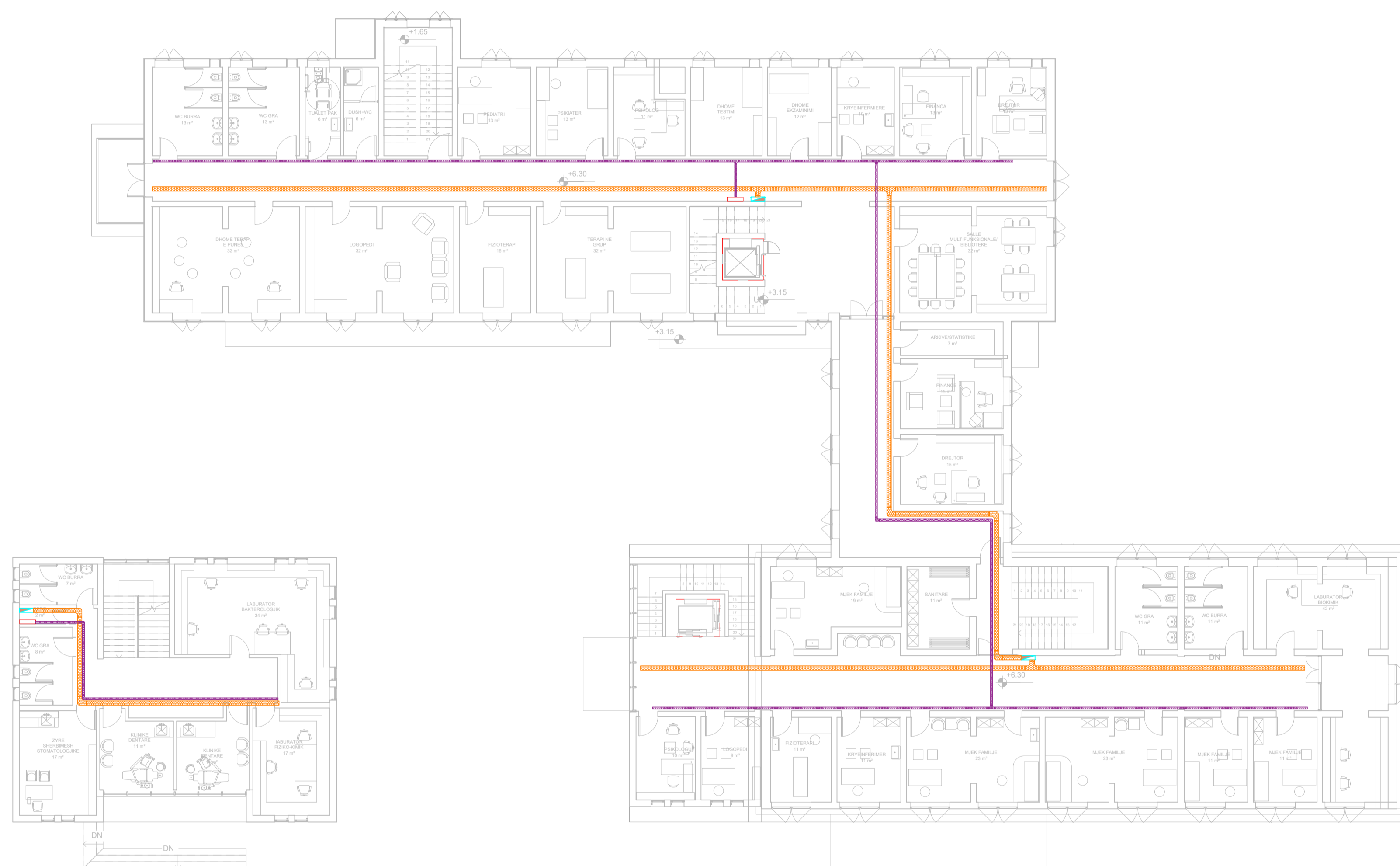

00	Tetor 2024	Projekt Lejë	

RISH. NR.	DATA	QËLLIMI I DORËZIMIT	SHENIM / PËRSHKRIM
-----------	------	---------------------	--------------------

INVESTITORI



**FONDI SHQIPTAR I ZHVILLIMIT**

KONSULENTI INXHINIERIK

Nr. Licencës: N.5221/16



**ICE**  
ILLYRIAN CONSULTING ENGINEERS  
Adresa: Rr. "Sami Frashëri", Pallat "Hoges", Katë 11, Tiranë, SHQIPËRI  
Tel/Fax: +355 4 200 911; Email: [office@ice.al](mailto:office@ice.al)  
[www.ice.al](http://www.ice.al)

Përgatit:	Pozicioni	Emri	Nr. Licencës	Firma
	Arkitekt	Edmond MANAHASA	A.0903/2	
	Ing. Strukturist	Anila SPAHIU	K.1068/4	
	Ing. Strukturist	Aida VOKA	K.1340/2	
	Ing. Hidroteknik	Artjola ZOTAJ	K.3443	
	Ing. Hidroteknik	Silvia GJONAJ		
	Ing. Hidroteknik	Anzhele BICI	K.3452	
	Ing. Elektrik	Enis HAVERIKU	E.1450	
	Ing. Elektrik	Ilber PUCI		
	Ing. Mekanik	Marsel PYLLA	M.1288/1	
Kontrollo:	Ing. Mekanik	Besnik KARAJ	M.0256/2	
	Koordinator Projekti	Abdurrahman SPAHIU	K.1571/5	
	Ing. Strukturist	Taulant KARRIQI	K.1547/6	
	Ing. Elektrik	Emira BERISHA	E.0550/4	
Mirato:	Drejues Projekti	Olset HAXHIU	K.1619/5	

TITULLI I PROJEKTIT

**INVESTIME PILOT PËR TRANSFORMIMIN E INFRASTRUKTURËS SË SHËRBBIMEVE DHE RRRITJES SË STANDARDIT TË JETËS NË KOMUNITET**









Objekti: Ndërhyrje për rikonstruksionin e spitalit të Peqinit dhe ndryshim i pjesshëm i funksionit të tij

EMRI I DOKUMENTIT



**PLANVENDOSJA E KANALINAVE ELEKTRIKE NË KATIN 1 / PLANVIEW OF ELECTRICAL CABLE TRAYS FOR 1ST FLOOR**

FAZA E PROJEKTIT PROJEKT LEJE	Nr. i Dokumentit	Shkalla	Rishikimi	Përmasa e fletës	Fleta
	E-01	1:150	00	A1 (841x594mm)	2/15



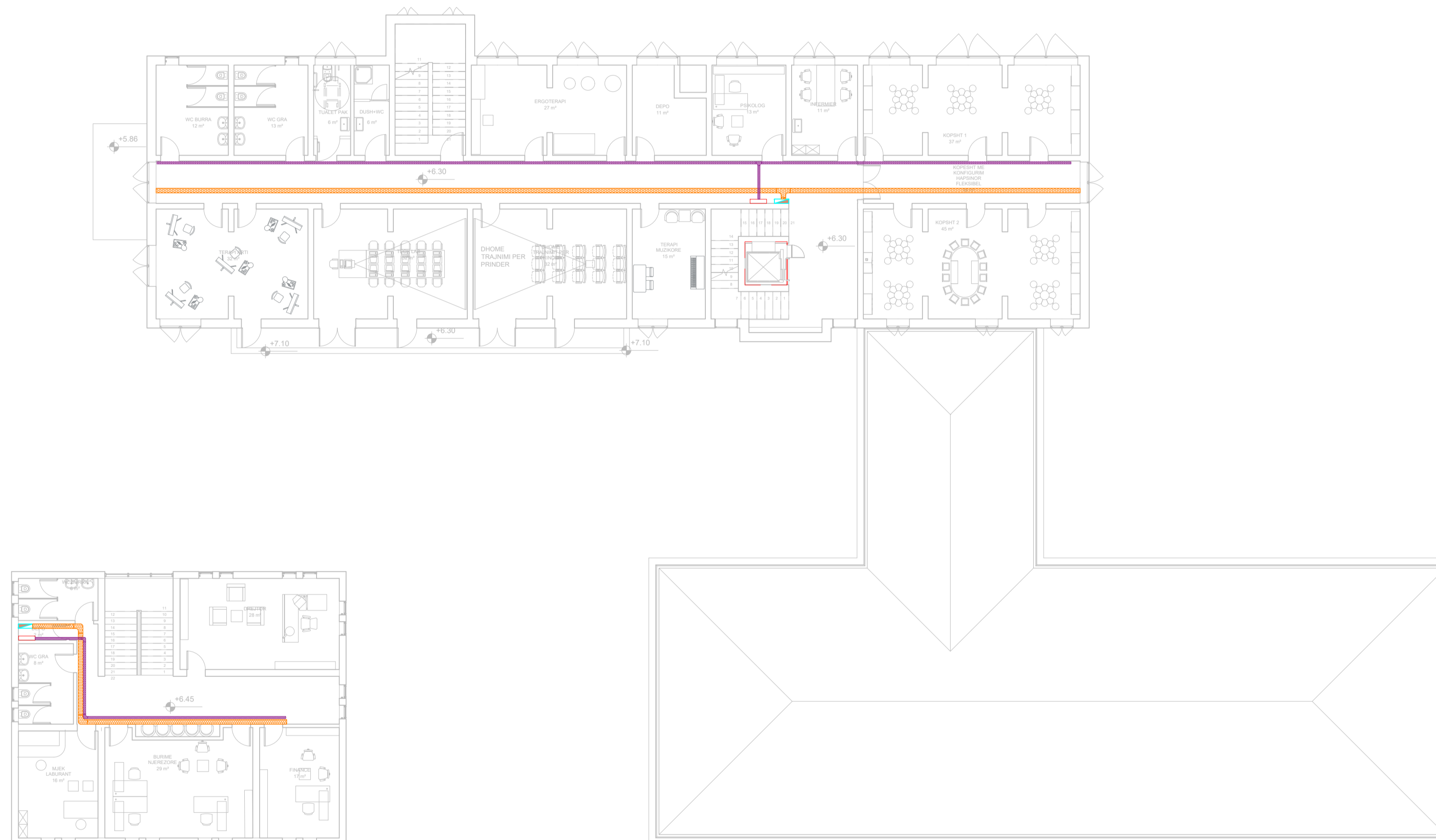





## Legjenda/Legend

-  Kanalina metalike për rrjetin e fuqisë, gjërësi 20 cm/Metallic cable tray, 20 cm width for power system network
-  Bryll 90 ° për kanalina me gjërësi 20 cm për rrjetin e fuqisë/Elbow with 90 ° for cable tray with 20 cm width for power system network
-  Degëzim për kanalina me gjërësi 20 cm për rrjetin e fuqisë/Branch for cable tray with 20 cm width for power system network
-  Kryqëzim për kanalina me gjërësi 20 cm për rrjetin e fuqisë/Junction for cable tray with 20 cm width for power system network
-  Kanalina metalike për rrjetin e sinjaleve, gjërësi 10 cm/Metallic cable tray, 10 cm width for data system network
-  Bryll 90 ° për kanalina me gjërësi 10 cm për rrjetin e sinjaleve/ Elbow with 90 ° for cable tray with 10 cm width for data system network
-  Degëzim për kanalina me gjërësi 10 cm për rrjetin e sinjaleve/Branch for cable tray with 10 cm width for data system network
-  Kryqëzim për kanalina me gjërësi 10 cm për rrjetin e sinjaleve/Junction for cable tray with 10 cm width for data system network





00		Tetor 2024		Projekt Lejë		
RISH. NR.	DATA	QËLLIMI I DORËZIMIT	SHENIM / PËRSHKRIM			
 <b>FONDI SHQIPTAR I ZHVILLIMIT</b>						
<b>KONSULENTI INXHINIERIK</b> Nr. Liqencës: N.5221/16  <b>ICÉ</b> ILLYRIAN CONSULTING ENGINEERS Adresa: Rr. "Sami Frashëri", Pallat "Hogea", Katë 11, Tiranë, SHQIPËRI Tel/Fax: +355 4 200 972, Email: info@ice.al www.ice.al						
Përgatiti:	Pozicioni	Emri	Nr. Licencës	Firma		
	Arkitekt	Edmond MANAHASA	A.0903/2	[Signature]		
	Ing. Strukturist	Anila SPAHIU	K.1068/4	[Signature]		
	Ing. Strukturist	Aida VOKA	K.1340/2	[Signature]		
	Ing. Hidroteknik	Artjola ZOTAJ	K.3443	[Signature]		
	Ing. Hidroteknik	Silvia GJONAJ		[Signature]		
	Ing. Hidroteknik	Anzhela BICI	K.3452	[Signature]		
	Ing. Elektrik	Enis HAVERIKU	E.1450	[Signature]		
	Ing. Elektrik	Ilber PUCI		[Signature]		
	Ing. Mekanik	Marsel PYLLA	M.1288/1	[Signature]		
Kontrolloi:	Ing. Mekanik	Besnik KARAJ	M.0256/2	[Signature]		
	Koordinator Projekti	Abdurrahman SPAHIU	K.1571/5	[Signature]		
	Ing. Strukturist	Taulant KARRIQI	K.1547/6	[Signature]		
	Ing. Elektrik	Emira BERISHA	E.0550/4	[Signature]		
Miratoi:	Drejues Projekti	Olset HAXHIU	K.1619/5	[Signature]		
<b>TITULLI I PROJEKTIT</b> <b>INVESTIME PILOT PËR TRANSFORMIMIN E INFRASTRUKTURËS SË SHËRBIEMEVE DHE RRTJES SË STANDARDIT TË JETËS NË KOMUNITET</b> <b>Objekti: Ndërrhyrje për rikonstruksionin e spitalit të Peqinit dhe ndryshim i pjesshëm i funksionit të tij</b>						
<b>EMRI I DOKUMENTIT</b> <b>PLANVENDOSJA E KANALINAVE ELEKTRIKE NË KATIN 2 / PLANVIEW OF ELECTRICAL CABLE TRAYS FOR 2ND FLOOR</b>						
FAZA E PROJEKTIT		Nr. i Dokumentit	Shkalla	Rishikimi	Përmasa e fletës	Fleta
PROJEKT LEJE		E-01	1:150	00	A1 (841x594mm)	3/15

## Legjenda/Legend

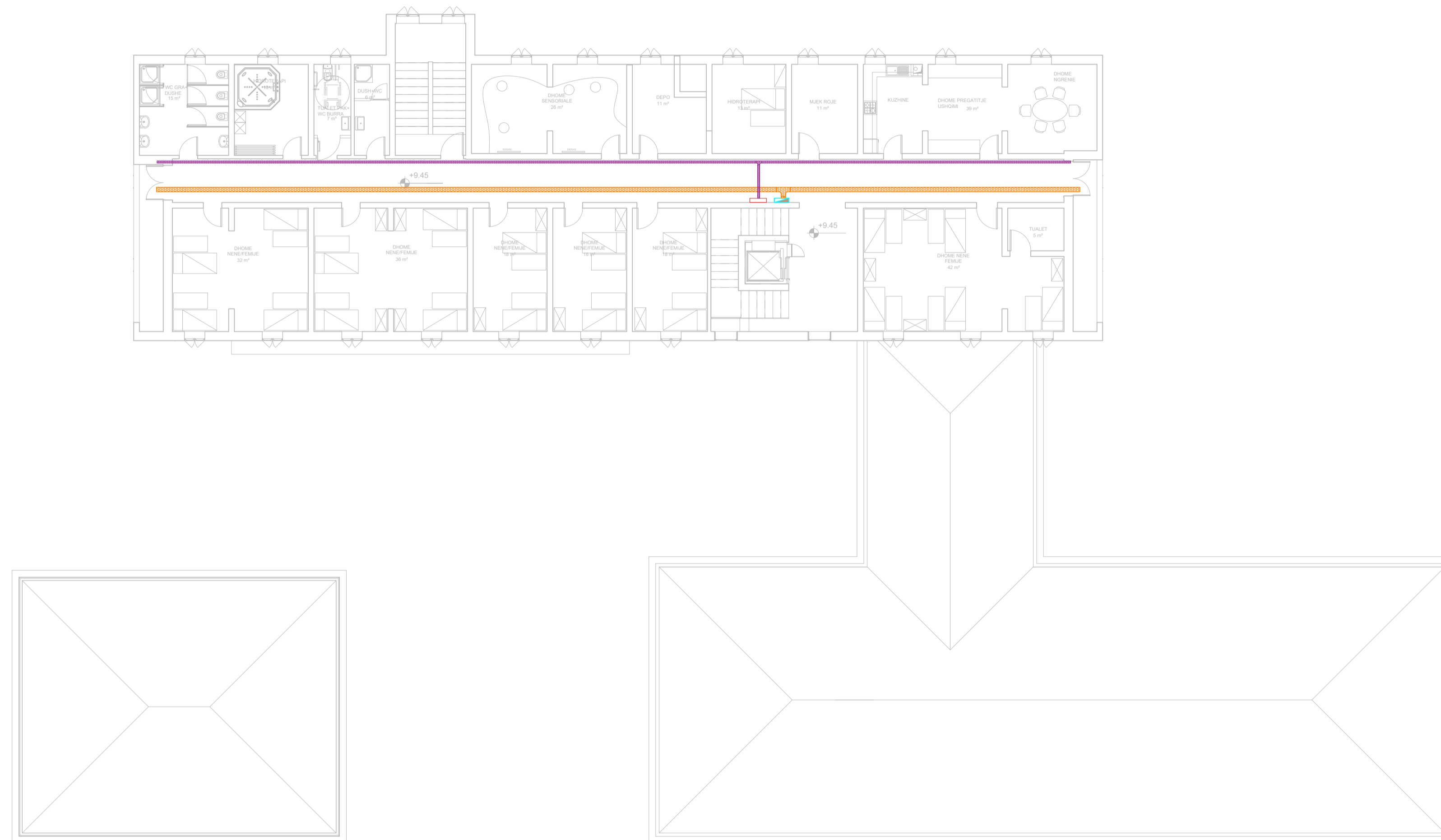
-  Kanalina metalike për rrjetin e fuqisë, gjërësi 20 cm/Metallic cable tray, 20 cm width for power system network
-  Bryll 90 ° për kanalina me gjërësi 20 cm për rrjetin e fuqisë/Elbow with 90 ° for cable tray with 20 cm width for power system network
-  Degëzim për kanalina me gjërësi 20 cm për rrjetin e fuqisë/Branch for cable tray with 20 cm width for power system network
-  Kryqëzim për kanalina me gjërësi 20 cm për rrjetin e fuqisë/Junction for cable tray with 20 cm width for power system network
-  Kanalina metalike për rrjetin e sinjaleve, gjërësi 10 cm/Metallic cable tray, 10 cm width for data system network
-  Bryll 90 ° për kanalina me gjërësi 10 cm për rrjetin e sinjaleve/ Elbow with 90 ° for cable tray with 10 cm width for data system network
-  Degëzim për kanalina me gjërësi 10 cm për rrjetin e sinjaleve/Branch for cable tray with 10 cm width for data system network
-  Kryqëzim për kanalina me gjërësi 10 cm për rrjetin e sinjaleve/Junction for cable tray with 10 cm width for data system network



00	Tetor 2024	Projekt Lejë	
RISH. NR.	DATA	QËLLIMI I DORËZIMIT	SHËNIMI / PËRSHKRIM
 <b>FONDI SHQIPTAR I ZHVILLIMIT</b>			
<b>KONSULENTI INXHINIERIK</b> Nr. Licencës: N.5221/16  <b>ICE</b> ILLYRIAN CONSULTING ENGINEERS Adresa: Rr. "Sami Frashëri", Pallat "Hogea", Katë 11, Tiranë, SHQIPËRI Tel/Fax: +355 4 200 972, Email: <a href="mailto:info@ice.al">info@ice.al</a> <a href="http://www.ice.al">www.ice.al</a>			
Përgatiti:	Pozicioni	Emri	Nr. Licencës
	Arkitekt	Edmond MANAHASA	A.0903/2
	Ing. Strukturist	Anila SPAHIU	K.1068/4
	Ing. Strukturist	Aida VOKA	K.1340/2
	Ing. Hidroteknik	Artjola ZOTAJ	K.3443
	Ing. Hidroteknik	Silvia GJONAJ	
	Ing. Hidroteknik	Anzhela BICI	K.3452
	Ing. Elektrik	Enis HAVERIKU	E.1450
	Ing. Elektrik	Ilber PUCI	
	Ing. Mekanik	Marsel PYLLA	M.1288/1
Kontrolloi:	Ing. Mekanik	Besnik KARAJ	M.0256/2
	Koordinator Projekti	Abdurrahman SPAHIU	K.1571/5
	Ing. Strukturist	Taulant KARRIQI	K.1547/6
	Ing. Elektrik	Emira BERISHA	E.0550/4
Miratoi:	Drejues Projekti	Olset HAXHIU	K.1619/5
<b>TITULLI I PROJEKTIT</b> <b>INVESTIME PILOT PËR TRANSFORMIMIN E INFRASTRUKTURËS SË SHËRBYEMEVE DHE RRRITJES SË STANDARDIT TË JETËS NË KOMUNITET</b> <b>Objekti: Ndërrhyrje për rikonstruksionin e spitalit të Peqinit dhe ndryshim i pjesshëm i funksionit të tij</b>			
<b>EMRI I DOKUMENTIT</b> <b>PLANVENDOSJA E KANALINAVE ELEKTRIKE NË KATIN 3 / PLANVIEW OF ELECTRICAL CABLE TRAYS FOR 3RD FLOOR</b>			
FAZA E PROJEKTIT	Nr. i Dokumentit	Shkalla	Rishikimi
PROJEKT LEJE	E-01	1:150	00
			Përmasa e fletës
			A1 (841x594mm)
			Fleta
			4/15

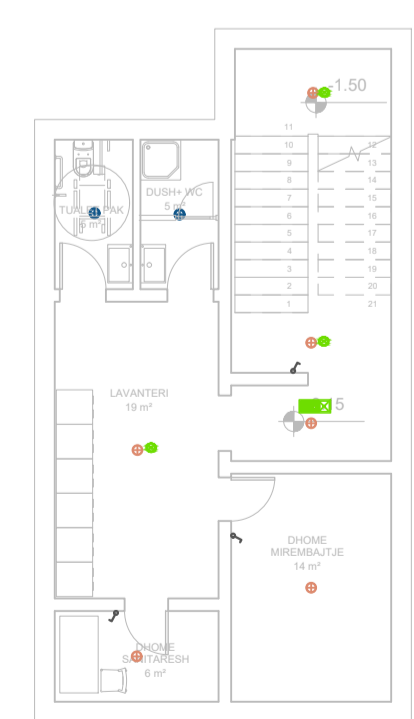

Kati -1

## Legjenda/Legend

- Kuader elektrik/Electric switchboard
- Prizë elektrike tip C/Electric socket, type C
- Prizë elektrike tip C me gjenerator /Electric socket, type C generator supply
- Prizë elektrike tip C m UPS /Electric socket, type C UPS supply
- Prizë elektrike tip C me transformator izolues /Electric socket, type C
- Prizë elektrike tip C dhe L në dysHEME/Electric Socket type C and L mounted on floor
- Çelës elektrik i thejsthtë/Universal switch
- Çelës elektrik deviator/Three way switch
- Çelës elektrik invertitor/Four way switch
- Ndrriqes elektrik LED, 60x60 /LED luminary, 60x60
- Ndrriqes elektrik LED, tip spot/LED luminary, spot type
- Ndrriqes elektrik LED, tip spot i komanduar me sensor/LED luminary, spot type controlled by sensor
- Ndrriqes elektrik LED mural, tip spot/LED luminary wall-mounted, spot type
- Ndrriqes elektrik LED i jashtem, i montuar ne shylle / Outdoor LED luminary, pole mounted
- Ndrriqes elektrik projektor LED, i montuar ne mur/ Projector LED luminary, wall mounted
- Ndrriqes emergjence LED, për montim në tavan/Emergency LED luminary, for mounting on ceiling
- Shenjë e ndriqar LED për evakuim (djalhtas ose majtas)
- Shenjë e ndriqar LED për evakuim (poshtë ose lart)
- Linja e furnizimit të prizave të fuqisë/Electric socket power supply line
- Linja e furnizimit të ndriqimit emergjent/Emergency lighting power supply line

00	Tetor 2024	Projekt Lejë			
RISH. NR.	DATA	QELIMI I DORËZIMIT	SHENIM / PERSHKRIM		
<p><b>FONDI SHQIPTAR I ZHVILLIMIT</b></p>					
<p>KONSULENTI INXHINIERIK</p> <p>Nr. Licencës: N.5221/16</p> <p><b>ICE</b> ILLYRIAN CONSULTING ENGINEERS Adresa: Rr. "Sami Frashëri", Pallat "Rruga", Kati 11, Tiranë, SHQIPËRI Tel/Fax: +355 4 200 972, Email: info@ice.al www.ice.al</p>					
Përgatiti:	Pozicioni	Emri	Nr. Licencës	Firma	
	Arktekt	Edmond MANAHASA	A.0903/2		
	Ing. Strukturist	Anila SPAHIU	K.1068/4		
	Ing. Strukturist	Aida VOKA	K.1340/2		
	Ing. Hidroteknik	Artjola ZOTAJ	K.3443		
	Ing. Hidroteknik	Silvia GJONAJ			
	Ing. Hidroteknik	Anzhela BICI	K.3452		
	Ing. Elektrik	Enis HAVERIKU	E.1450		
	Ing. Elektrik	Ilber PUCI			
	Ing. Mekanik	Marsel PYLLA	M.1288/1		
Kontrolloi:	Ing. Mekanik	Besnik KARAJ	M.0256/2		
	Koordinator Projekti	Abdurrahman SPAHIU	K.1571/5		
	Ing. Strukturist	Taulant KARRIQI	K.1547/6		
	Ing. Elektrik	Emira BERISHA	E.0550/4		
Miratoi:	Drejtes Projekti	Oset HAXHIU	K.1619/5		
<p>TITULLI I PROJEKTIT</p> <p><b>INVESTIME PILOT PËR TRANSFORMIMIN E INFRASTRUKTURËS SË SHËRBIMEVE DHE RRIJTJES SË STANDARDIT TË JETËS NË KOMUNITET</b></p> <p><b>Objekti: Ndërrhyrje për rikonstrukcionin e spitalit të Peqinit dhe ndryshim i pjesshëm i funksionit të tij</b></p>					
<p>EMRI I DOKUMENTIT</p> <p><b>PLANVENDOSJA E PRIZAVE, NDRIQËSVE NORMAL, EMERGJENCË, SHENJAVE TË EVAKUIMIT, SENSORËVE TË KOMANDIMIT TË NDRIQIMIT TË BRNDSHËM DHE TË JASHTËM NË KATIN -1 DHE 0 //PLANVIEW OF NORMAL AND EMERGENCY LUMINARIES, EVACUATION SIGNS AND OUTDOOR AND INDOOR LIGHTING CONTROL SENSORS FOR FLOOR -1 AND 0</b></p>					
FAZA E PROJEKTIT	Nr. i Dokumentit	Shkalla	Rishikimi	Përmasa e fletës	Fleta
PROJEKT LEJE	E-01	1:150	00	A1 (841x594mm)	5/15

Legjenda/Legend

- Kuader elektrik/Electric switchboard
- Prizë elektrike tip C/Electric socket, type C
- Prizë elektrike tip C me gjenerator /Electric socket, type C generator supply
- Prizë elektrike tip C m UPS /Electric socket, type C UPS supply
- Prizë elektrike tip C me transformator izolues /Electric socket, type C
- Prizë elektrike tip C dhe L në dyshe/Electric Socket type C and L mounted on floor
- Çelës elektrik i thejshëm/Universal switch
- Çelës elektrik deviator/Three way switch
- Çelës elektrik invertitor/Four way switch
- Ndiçues elektrik LED, 60x60 /LED luminary, 60x60
- Ndiçues elektrik LED, tip spot/LED luminary, spot type
- Ndiçues elektrik LED, tip spot i komanduar me sensor/LED luminary, spot type controlled by sensor
- Ndiçues elektrik LED mural, tip spot/LED luminary wall-mounted, spot type
- Ndiçues elektrik LED i jashtëm, i montuar ne shylle / Outdoor LED luminary, pole mounted
- Ndiçues elektrik projektor LED, i montuar ne mur/ Projector LED luminary, wal. mounted
- Ndiçues emergjence LED, për montim në tavan/Emergency LED luminary, for mounting on ceiling
- Sherjë e ndriçuar LED për evakuim (djathtas ose majtas)
- Sherjë e ndriçuar LED për evakuim (poshtë ose lart)
- Linja e furnizimit të prizave të fuqisë/Electric socket power supply line
- Linja e furnizimit të ndriçimit emergjent/Emergency lighting power supply line

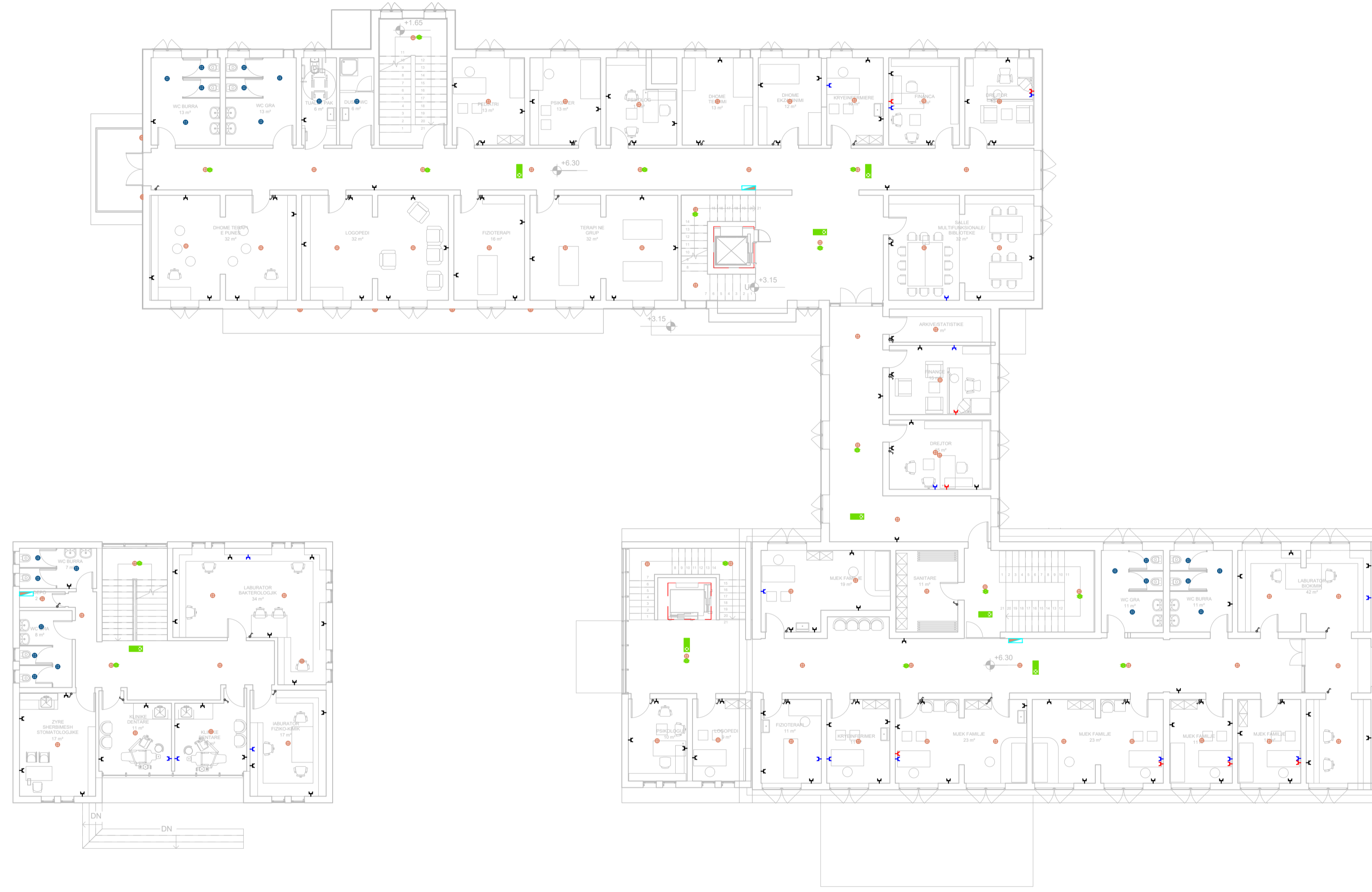

00	Tetor 2024	Projekt Lejë					
RISH. NR.	DATA	QELIMI I DORËZIMIT	SHENIM / PERSHKRIM				

**FONDI SHQIPTAR I ZHVILLIMIT**

**KONSULENTI INXHINIERIK**  
 Nr. Licencës: N.5221/16  
**ICE**  
ILLYRIAN CONSULTING ENGINEERS  
 Adresa: Rr. "Sami Frashëri", Pallat "Rigori", Kati 11, Tiranë, SHQIPËRI  
 Tel/Fax: +355 4 200 972, Email: info@ice.al  
 www.ice.al

Përgatiti:	Pozicioni	Emri	Nr. Licencës	Firma
	Arktekt	Edmond MANAHASA	A.0903/2	
	Ing. Strukturist	Anila SPAHIU	K.1068/4	
	Ing. Strukturist	Aida VOKA	K.1340/2	
	Ing. Hidroteknik	Artjola ZOTAJ	K.3443	
	Ing. Hidroteknik	Silvia GJONAJ		
	Ing. Hidroteknik	Anzhela BICI	K.3452	
	Ing. Elektrik	Enis HAVERIKU	E. 1450	
	Ing. Elektrik	Ilber PUCI		
	Ing. Mekanik	Marsel PYLLA	M.1288/1	
	Ing. Mekanik	Besnik KARAJ	M.0256/2	
Kontrollor:	Koordinator Projekti	Abdurrahman SPAHIU	K.1571/5	
	Ing. Strukturist	Taulant KARRIQI	K.1547/6	
	Ing. Elektrik	Emira BERISHA	E.0550/4	
Mirator:	Drejues Projekti	Oset HAXHIU	K.1619/5	

**TITULLI I PROJEKTIT**  
**INVESTIME PILOT PËR TRANSFORMIMIN E INFRASTRUKTURËS SË SHËRBIMEVE DHE RRRITJES SË STANDARDIT TË JETËS NË KOMUNITET**  
**Objekti: Ndërrhyrje për rikonstrukcionin e spitalit të Peqinit dhe ndryshim i pjesshëm i funksionit të tij**







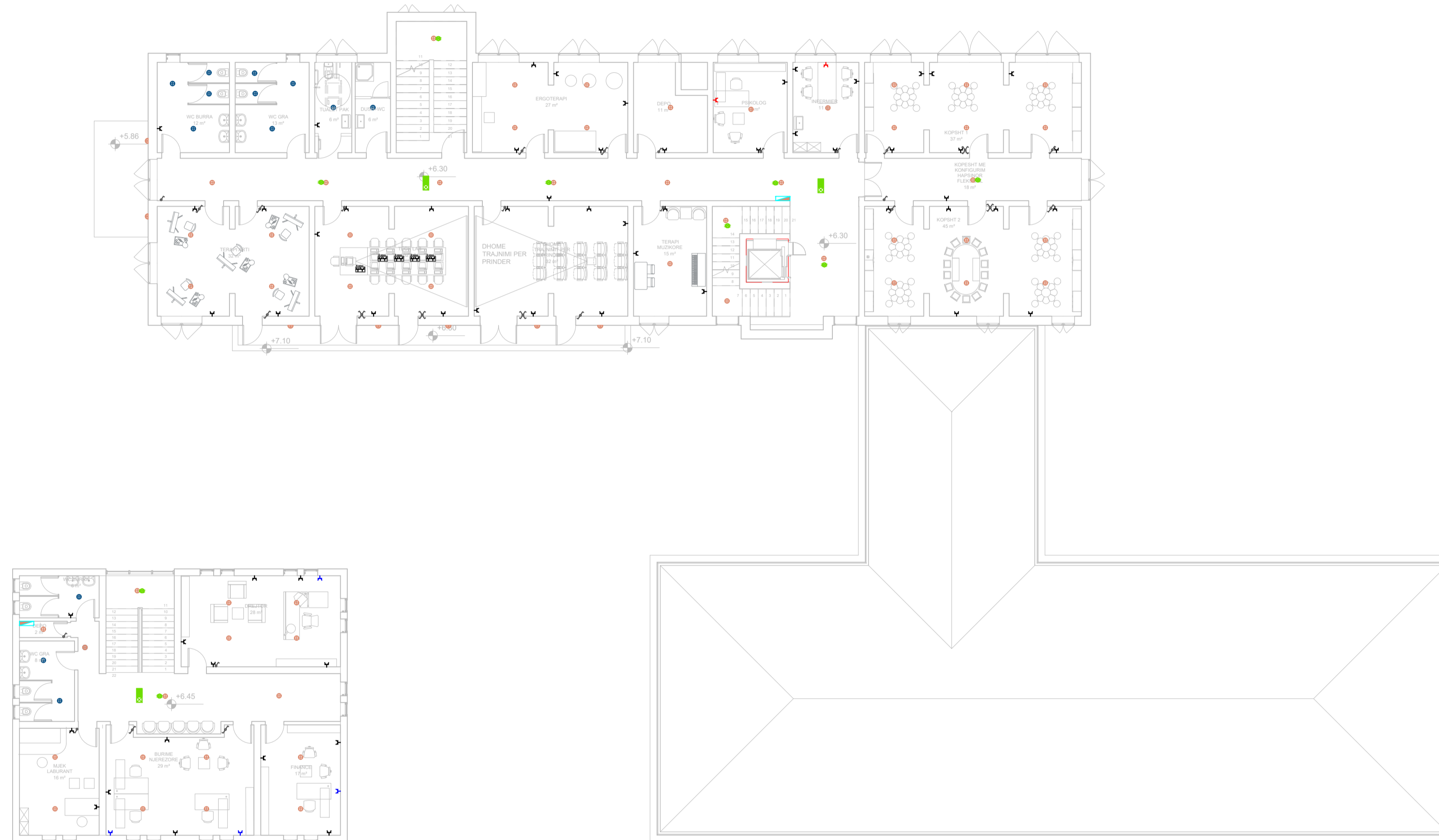

**EMRI I DOKUMENTIT**  
**PLANVENDOSJA E PRIZAVE, NDIÇUESVE NORMAL, EMERGJENCË, SHENJAVE TË EVAKUIMIT, SENSORËVE TË KOMANDIMIT TË NDIÇIMIT NË KATIN 1 //PLANVIEW OF NORMAL AND EMERGENCY LUMINARIES, EVACUATION SIGNS AND LIGHTING CONTROL SENSORS FOR 1ST FLOOR**

FAZA E PROJEKTIT	Nr. i Dokumentit	Shkalla	Rishikimi	Përmasa e fletës	Fleta
PROJEKT LEJE	E-01	1:150	00	A1 (841x594mm)	6/15

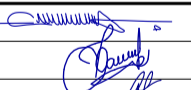
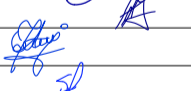
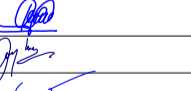
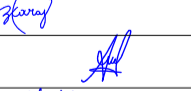
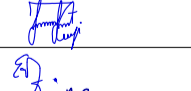

















## Legjenda/Legend

-  Kuader elektrik/Electric switchboard
-  Prizë elektrike tip C/Electric socket, type C
-  Prizë elektrike tip C me gjenerator /Electric socket, type C generator supply
-  Prizë elektrike tip C m UPS /Electric socket, type C UPS supply
-  Prizë elektrike tip C me transformator izolues /Electric socket, type C
-  Prizë elektrike tip C dhe L në dysHEME/Electric Socket type C and L mounted on floor
-  Çelës elektrik i thejshëm/Universal switch
-  Çelës elektrik deviator/Three way switch
-  Çelës elektrik invertitor/Four way switch
-  Ndrichues elektrik LED, 60x60 /LED luminary, 60x60
-  Ndrichues elektrik LED, tip spot/LED luminary, spot type
-  Ndrichues elektrik LED, tip spot i komanduar me sensor/LED luminary, spot type controlled by sensor
-  Ndrichues elektrik LED mural, tip spot/LED luminary wall-mounted, spot type
-  Ndrichues elektrik LED i jashtem, i montuar ne shylle / Outdoor LED luminary, pole mounted
-  Ndrichues elektrik projektor LED, i montuar ne mur/ Projector LED luminary, wall-mounted
-  Ndrichues emergjence LED, për montim në tavan/Emergency LED luminary, for mounting on ceiling
-  Shenjë e ndriqar LED për evakuim (djalhtas ose majtas)
-  Shenjë e ndriqar LED për evakuim (poshtë ose lart)
-  Linja e furnizimit të prizave të fuqisë/Electric socket power supply line
-  Linja e furnizimit të ndriçimit emergjent/Emergency lighting power supply line





00	Tetor 2024	Projekt Lejë			
RISH. NR.	DATA	QELIMI I DORËZIMIT	SHENIMI / PËRSHKRIM		
 <b>FONDI SHQIPTAR I ZHVILLIMIT</b>					
<b>KONSULENTI INXHINIERIK</b> Nr. Licencës: N.5221/16  ILLYRIAN CONSULTING ENGINEERS Adresa: Rr. "Sami Frashëri", Pallat "Hera", Katë 11, Tiranë, SHQIPËRI Tel/Fax: +355 4 200 972, Email: info@ice.al, www.ice.al					
Përgatiti:	Pozicioni	Emri	Nr. Licencës	Firma	
	Arkitekt	Edmond MANAHASA	A.0903/2		
	Ing. Strukturist	Anila SPAHIU	K.1068/4		
	Ing. Strukturist	Aida VOKA	K.1340/2		
	Ing. Hidroteknik	Artjola ZOTAJ	K.3443		
	Ing. Hidroteknik	Silvia GJONAJ			
	Ing. Hidroteknik	Anzhela BICI	K.3452		
	Ing. Elektrik	Enis HAVERIKU	E.1450		
	Ing. Elektrik	Ilber PUCI			
	Ing. Mekanik	Marsel PYLLA	M.1288/1		
Kontrolloi:	Ing. Mekanik	Besnik KARAJ	M.0256/2		
	Koordinator Projekti	Abdurrahman SPAHIU	K.1571/5		
	Ing. Strukturist	Taulant KARRIQI	K.1547/6		
	Ing. Elektrik	Emira BERISHA	E.0550/4		
Miratoi:	Drejues Projekti	Olset HAXHIU	K.1619/5		
<b>TITULLI I PROJEKTIT</b> <b>INVESTIME PILOT PËR TRANSFORMIMIN E INFRASTRUKTURËS SË SHËRBIEMEVE DHE RRRITJES SË STANDARDIT TË JETËS NË KOMUNITET</b> <b>Objekti: Ndërrhyrje për rikonstrukcionin e spitalit të Peqinit dhe ndryshim i pjesshëm i funksionit të tij</b>					
<b>EMRI I DOKUMENTIT</b> <b>PLANVENDOSJA E PRIZAVE, NDRICHËSVE NORMAL, EMERGJENCË, SHENJAVE TË EVAKUIMIT, SENSORËVE TË KOMANDIMIT TË NDRICHIMIT NË KATIN 2 //PLANVIEW OF NORMAL AND EMERGENCY LUMINARIES, EVACUATION SIGNS AND LIGHTING CONTROL SENSORS FOR 2ND FLOOR</b>					
FAZA E PROJEKTIT	Nr. i Dokumentit	Shkalla	Rishikimi	Përmasa e fletës	Fleta
PROJEKT LEJË	E-01	1:150	00	A1 (841x594mm)	7/15

# Legjenda/Legend

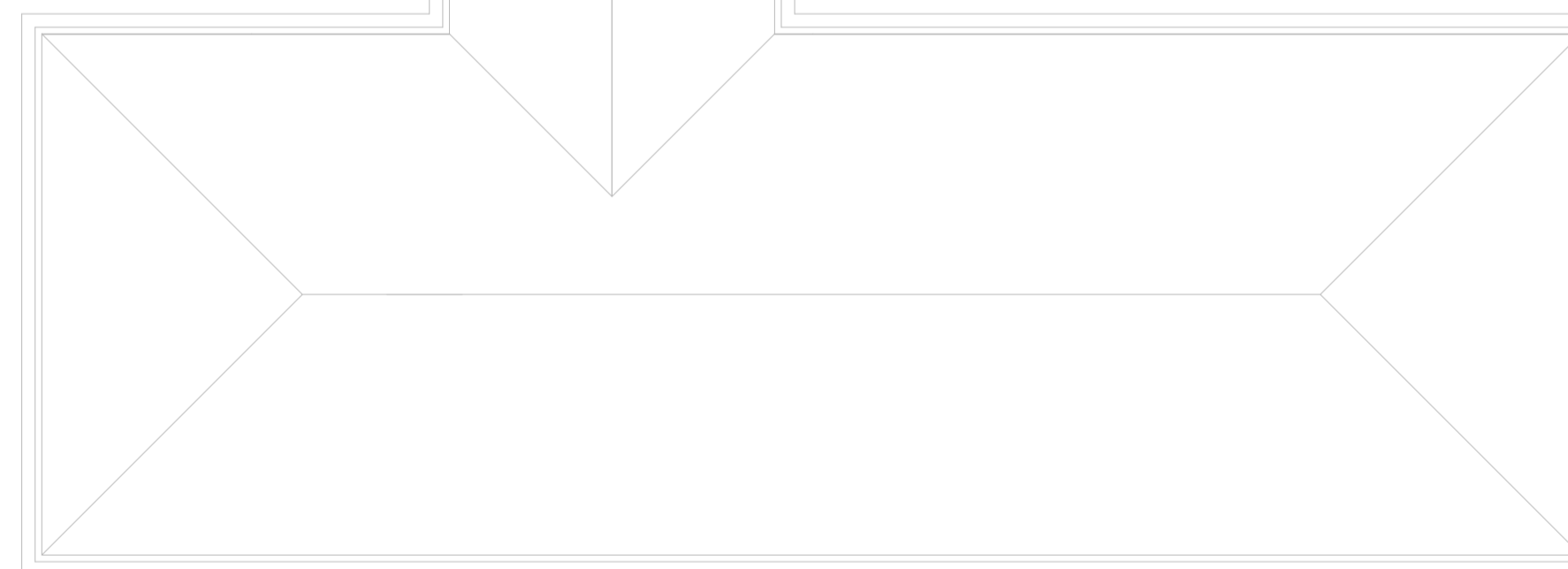
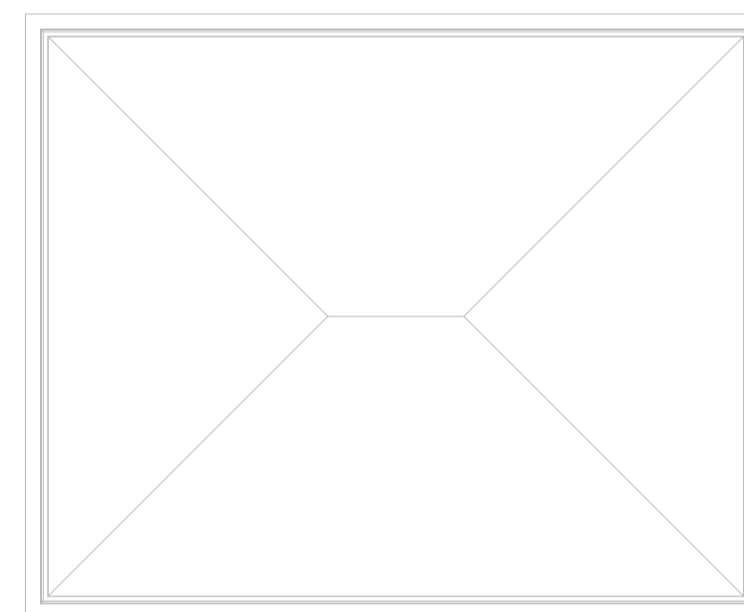
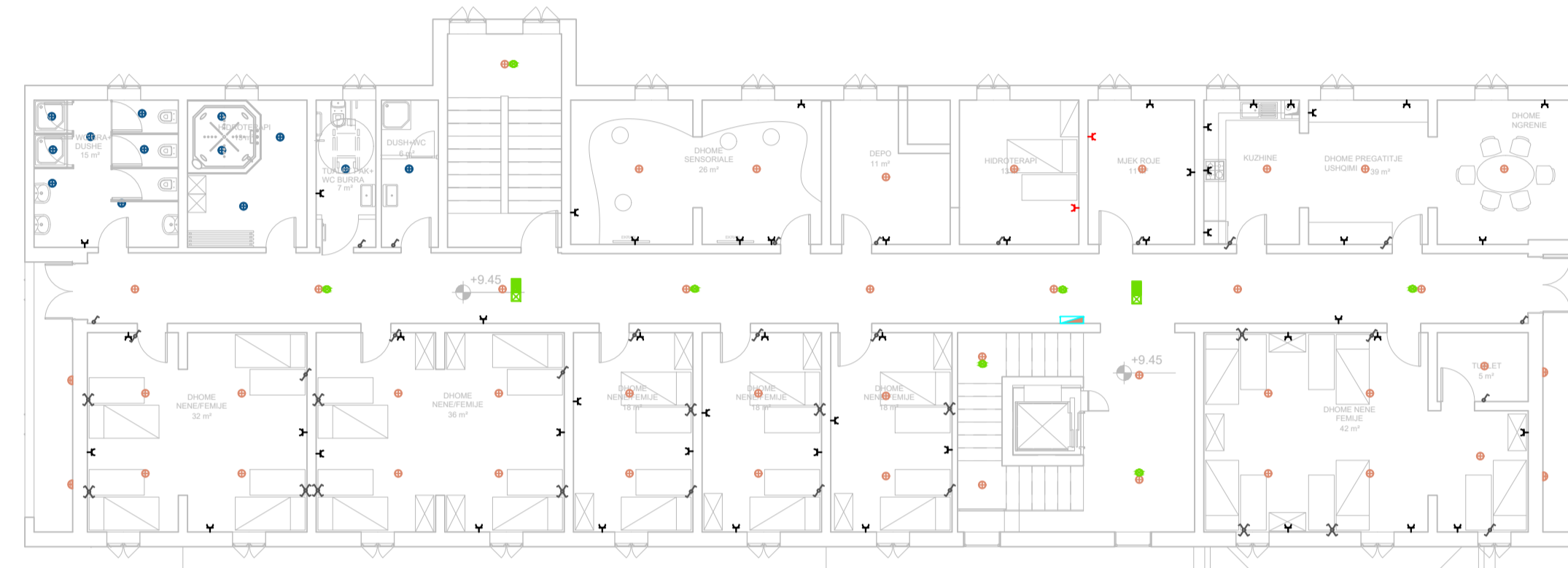
-  Kuader elektrik/Electric switchboard
-  Prizë elektrike tip C/Electric socket, type C
-  Prizë elektrike tip C me gjenerator /Electric socket, type C generator supply
-  Prizë elektrike tip C m UPS /Electric socket, type C UPS supply
-  Prizë elektrike tip C me transformator izolues /Electric socket, type C
-  Prizë elektrike tip C dhe L në dysHEME/Electric Socket type C and L mounted on floor
-  Çelës elektrik i thejshëm/Universal switch
-  Çelës elektrik deviator/Three way switch
-  Çelës elektrik invertitor/Four way switch
-  Ndrriqes elektrik LED, 60x60 /LED luminary, 60x60
-  Ndrriqes elektrik LED, tip spot/LED luminary, spot type
-  Ndrriqes elektrik LED, tip spot i komanduar me sensor/LED luminary, spot type controlled by sensor
-  Ndrriqes elektrik LED mural, tip spot/LED luminary wall-mounted, spot type
-  Ndrriqes elektrik LED i jashtem, i montuar ne shylle / Outdoor LED luminary, pole mounted
-  Ndrriqes elektrik projektor LED, i montuar ne mur/ Projector LED luminary, wal. mounted
-  Ndrriqes emergency LED, për montim në tavan/Emergency LED luminary, for mounting on ceiling
-  Sherjë e ndrriqar LED për evakuim (djathtas ose majtas)
-  Sherjë e ndrriqar LED për evakuim (poshtë ose lart)
-  Linja e furnizimit të prizave të fuqisë/Electric socket power supply line
-  Linja e furnizimit të ndrriqimit emergjent/Emergency lighting power supply line







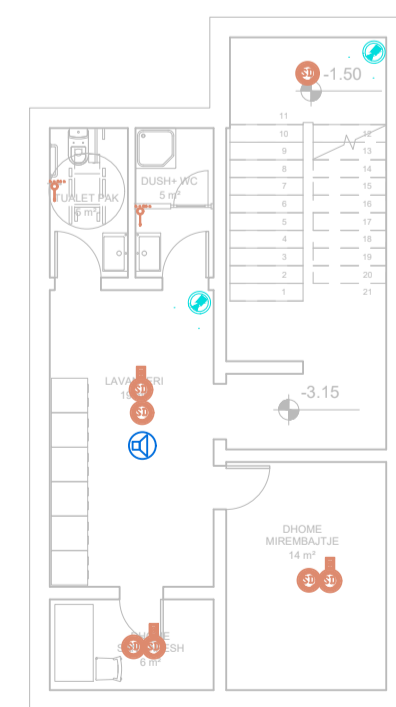











00	Tetor 2024	Projekt Lejë							
RISH. NR.	DATA	QËLLIMI I DORËZIMIT	SHENIMI / PËRSHKRIM						
 <b>FONDI SHQIPTAR I ZHVILLIMIT</b>									
<b>KONSULENTI INXHINIERIK</b> Nr. Licencës: N.5221/16  <b>ICÉ</b> ILLYRIAN CONSULTING ENGINEERS <small>Adresa: Rr. "Sami Frashëri", Pallat "Bjorin", Katë 11, Tiranë, SHQIPËRI</small> <small>Tel/Fax: +355 4 260 972; E-mail: info@ice.al</small> <small>www.ice.al</small>									
Përgatiti:	Pozicioni	Emri	Nr. Licencës	Firma					
	Arkitekt	Edmond MANAHASA	A.0903/2						
	Ing. Strukturist	Anila SPAHIU	K.1068/4						
	Ing. Strukturist	Aida VOKA	K.1340/2						
	Ing. Hidroteknik	Artjola ZOTAJ	K.3443						
	Ing. Hidroteknik	Silvia GJONAJ							
	Ing. Hidroteknik	Anzhela BICI	K.3452						
	Ing. Elektrik	Enis HAVERIKU	E.1450						
	Ing. Elektrik	Ilber PUCI							
	Ing. Mekanik	Marsel PYLLA	M.1288/1						
Kontrolloi:	Ing. Mekanik	Besnik KARAJ	M.0256/2						
	Koordinator Projekti	Abdurrahman SPAHIU	K.1571/5						
	Ing. Strukturist	Taulant KARRIQI	K.1547/6						
	Ing. Elektrik	Emira BERISHA	E.0550/4						
Miratoi:	Drejues Projekti	Olset HAXHIU	K.1619/5						
<b>TITULLI I PROJEKTIT</b> <b>INVESTIME PILOT PËR TRANSFORMIMIN E INFRASTRUKTURËS SË SHËRBIEMEVE DHE RRIJES SË STANDARDIT TË JETËS NË KOMUNITET</b> <b>Objekti: Ndërrhyrje për rikonstruksionin e spitalit të Peqinit dhe ndryshim i pjesshëm i funksionit të tij</b>									
<b>EMRI I DOKUMENTIT</b> <b>PLANVENDOSJA E PRIZAVE, NDRRIQESVE NORMAL, EMERGJENCË, SHENJAVE TË EVAKUIMIT, SENSORËVE TË KOMANDIMIT TË NDRRIQIMIT NË KATIN 3 //PLANVIEW OF NORMAL AND EMERGENCY LUMINARIES, EVACUATION SIGNS AND LIGHTING CONTROL SENSORS FOR 3RD FLOOR</b>									
FAZA E PROJEKTIT		Nr. i Dokumentit	Shkalla	Rishikimi	Përmasa e fletës	Fleta			
PROJEKT LEJË		E-01	1:150	00	A1 (841x594mm)	8/15			























Kati -1

Legjenda/Legend





-  Kuader elektrik/Electric switchboard
-  Prizë LAN / LAN socket
-  Kamera me IP, tip kupole/IP Camera, type dome
-  Sensor tymi, për montim në tavan betoni/Smoke sensor, for mounting on concrete ceiling
-  Sensor tymi me sensor shtesë, për montim në tavan gipsi/Smoke sensor with additional sensor, for mounting on concrete ceiling
-  Buton alarmi në rast zjarri/Fire protection alarm button
-  Sirenë alarmi/Alarm sirenë
-  /Shirit LED/LED strip
-  Lexues aksesi/Access reader
-  Bravë elektrike/Electric lock
-  Çelës fundor për sinjalizim në rast rreziku në nevojore/Limit switch for sharing the risk to central management in case of any risk in WC
-  Boks tavanor /Ceiling-mounted speaker
-  Linjë e të dhënave/LAN data line
-  Linjë e TV/TV Line
-  Linjë e mbrojtjes nga zjarri/Firefighting protection line
-  Linjë KNX për sistemin e menaxhimit të dhomës/KNX line for room management facilities
-  Linjë e sistemit të evakuimit zazor/Audio evacuation system line

00	Tetor 2024	Projekt Lejë			
RISH. NR.	DATA	QELIMI I DORËZIMIT	SHENIM / PERSHKRIM		
 <b>FONDI SHQIPTAR I ZHVILLIMIT</b>					
<b>KONSULENTI INXHINIERIK</b> Nr. Licencës: N.5221/16  <b>ICÉ</b> <small>ILLYRIAN CONSULTING ENGINEERS          Adresa: Rr. "Sami Frashëri", Pallat "Hogos", Katë 11, Tiranë, SHQIPËRI          Tel/Fax: +355 4 200 972, Email: info@ice.al          www.ice.al</small>					
Përgatiti:	Pozicioni	Emri	Nr. Licencës	Firma	
	Arkitekt	Edmond MANAHASA	A.0903/2		
	Ing. Strukturist	Anila SPAHIU	K.1068/4		
	Ing. Strukturist	Aida VOKA	K.1340/2		
	Ing. Hidroteknik	Artjola ZOTAJ	K.3443		
	Ing. Hidroteknik	Silvia GJONAJ			
	Ing. Hidroteknik	Anzhela BICI	K.3452		
	Ing. Elektrik	Enis HAVERIKU	E.1450		
	Ing. Elektrik	Ilber PUCI			
	Ing. Mekanik	Marsel PYLLA	M.1288/1		
Kontrolli:	Ing. Mekanik	Besnik KARAJ	M.0256/2		
	Koordinator Projekti	Abdurrahman SPAHIU	K.1571/5		
	Ing. Strukturist	Taulant KARRIQI	K.1547/6		
	Ing. Elektrik	Emira BERISHA	E.0550/4		
Miratori:	Drejues Projekti	Olset HAXHIU	K.1619/5		
<b>TITULLI I PROJEKTIT</b> <b>INVESTIME PILOT PËR TRANSFORMIMIN E INFRASTRUKTURËS SË SHËRBIMEVE DHE RRTJES SË STANDARDIT TË JETËS NË KOMUNITET</b> <b>Objekti: Ndërrhyrje për rikonstrukcionin e spitalit të Peqinit dhe ndryshim i pjesshëm i funksionit të tij</b>					
<b>EMRI I DOKUMENTIT</b> <b>PLANVENDOSJA E KAMERAVE, PRIZAVE TË INTERNETIT, RRJETI I DEDEKTIMIT TË ZJARRIT, AKSES KONTROLL DHE KOMUNIKIMI ZANOR NË KATIN -1 DHE 0 //PLANVIEW OF CAMERAS, LAN SOCKETS, FIRE DETECTION, ACCESS CONTROL AND VOICE ANNOUNCEMENTS FOR FLOOR -1 AND 0</b>					
FAZA E PROJEKTIT					
PROJEKT LEJE	Nr. i Dokumentit	Shkalla	Rishikimi	Përmasa e fletës	Fleta
	E-01	1:150	00	A1 (841x594mm)	9/15



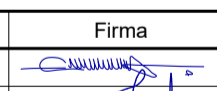
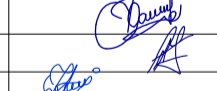

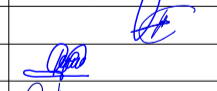
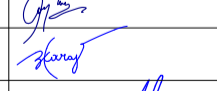
### Legjenda/Legend

-  Kuader elektrik/Electric switchboard
-  Prizë LAN / LAN socket
-  Kamera me IP, tip kupole/IP Camera, type dome
-  Sensor tymi, për montim në tavan betoni/Smoke sensor, for mounting on concrete ceiling
-  Sensor tymi me sensor shtesë, për montim në tavan gipsi/Smoke sensor with additional sensor, for mounting on concrete ceiling
-  Buton alarmi në rast zjarri/Fire protection alarm button
-  Sirenë alarmi/Alarm siren
-  /Shirit LED/LED strip
-  Lexues aksesi/Access reader
-  Bravë elektrike/Electric lock
-  Çelës fundor për sinjalizim në rast treziku në nevojore/Limit switch for sharing the risk to central management in case of any risk in WC
-  Boks tavanor /Ceiling-mounted speaker
-  Linja e të dhënave/LAN data line
-  Linja e TV/TV Line
-  Linja e mbrojtjes nga zjarri/Firefighting protection line
-  Linja KNX për sistemin e menaxhimit të dhomës/KNX line for room management facilities
-  Linja e sistemit të evakuimit zanor/Audio evacuation system line







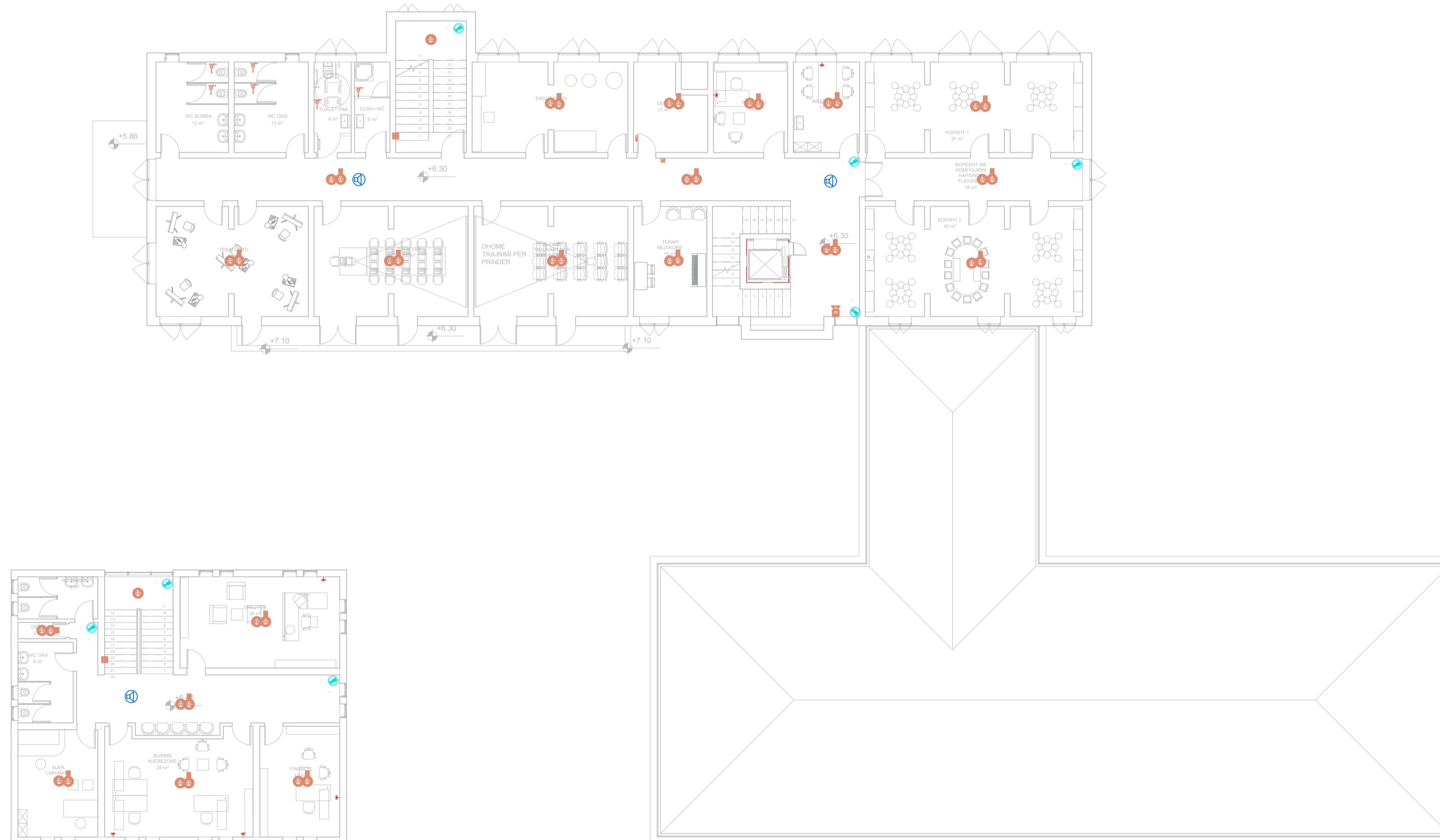

00	Tetor 2024	Projekt Lejë			
RISH. NR.	DATA	QËLLIMI I DORËZIMIT	SHENIM / PËRSHKRIM		
 <b>FONDI SHQIPTAR I ZHVILLIMIT</b>					
<b>KONSULENTI INZHINIERIK</b> <b>ice</b> <small>ILLYRIAN CONSULTING ENGINEERS Adresa: Rr. "Bambasheva", Pallat "Binga", Kat 11, Tiranë, SHQIPËRI Tëlfax: +355 4 390 912, E-mail: info@ice.al www.ice.al</small>					
Nr. Licencës: N.5221/16					
Përgatiti:	Pozicioni	Emri	Nr. Licencës	Firma	
	Arktekt	Edmond MANAHASA	A.0903/2		
	Ing. Strukturist	Anila SPAHIU	K.1068/4		
	Ing. Strukturist	Alda VOKA	K.1340/2		
	Ing. Hidroteknik	Artjola ZOTAJ	K.3443		
	Ing. Hidroteknik	Silvia GJONAJ	K.3452		
	Ing. Hidroteknik	Anzhela BICI	E.1450		
	Ing. Elektrik	Enis HAVERIKU	M.1288/1		
	Ing. Elektrik	Iiber PUCI	M.0256/2		
	Ing. Mekanik	Marsel PYLLA	K.1571/5		
Kontrolloi:	Ing. Mekanik	Besnik KARAJ	K.1547/6		
	Koordinator Projekti	Abdurrahman SPAHIU	E.0550/4		
	Ing. Strukturist	Taulant KARRIQI	K.1619/5		
Miratoi:	Ing. Elektrik	Emira BERISHA			
Direktues Projekti					
Oset HAXHIU					
TITULLI I PROJEKTTIT					
<b>INVESTIME PILOT PËR TRANSFORMIMIN E INFRASTRUKTURËS SË SHËRBIMEVE DHE RRITJES SË STANDARDIT TË JETËS NË KOMUNITET</b> <b>Objekti: Ndërhyrje për rikonstruksionin e spitalit të Peqinit dhe ndryshim i pjesshëm i funksionit të tij</b>					
EMRI I DOKUMENTIT					
<b>PLANVENDOSJA E KAMERAVE, PRIZAVE TË INTERNETIT, RRJETI I DEDEKTIMIT TË ZJARRIT, AKSES KONTROLL DHE KOMUNIKIMI ZANOR NË KATIN 1 /PLANVIEW OF CAMERAS, LAN SOCKETS, FIRE DETECTION, ACCESS CONTROL AND VOICE ANNOUNCEMENTS FOR 1ST FLOOR</b>					
FAZA E PROJEKTTIT	Nr. i Dokumentit	Shkalla	Rishikimi	Përmasa e fletës	Fleta
PROJEKT LEJE	E-01	1:150	00	A1 (841x594mm)	10/15



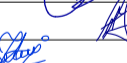
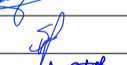

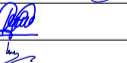
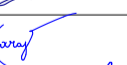
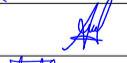
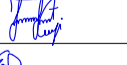
## Legjenda/Legend

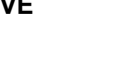
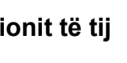
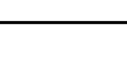
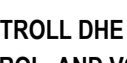
-  Kuader elektrik/Electric switchboard
-  Prizë LAN / LAN socket
-  Kamera me IP, tip kupole/IP Camera, type dome
-  Sensor tymi, për montim në tavan betoni/Smoke sensor, for mounting on concrete ceiling
-  Sensor tymi me sensor shtesë, për montim në tavan gipsi/Smoke sensor with additional sensor, for mounting on concrete ceiling
-  Buton alarmi në rast zjarri/Fire protection alarm button
-  Sirenë alarmi/Alarm sirene
-  /Shirit LED/LED strip
-  Lexues aksesit/Access reader
-  Bravë elektrike/Electric lock
-  Çelës fundor për sinjalizim në rast treziku në nevojore/Limit switch for sharing the risk to central management in case of any risk in WC
-  Boks tavanor /Ceiling-mounted speaker
-  Linjë e të dhënave/LAN data line
-  Linjë e TV/TV Line
-  Linjë e mbrojtjes nga zjarri/Firefighting protection line
-  Linjë KNX për sistemin e menaxhimit të dhomës/KNX line for room management facilities
-  Linjë e sistemit të evakuimit znanor/Audio evacuation system line





00	Tetor 2024	Projekt Lejë			
RISH. NR.	DATA	QËLLIMI I DORËZIMIT	SHËNIMI / PËRSHKRIMI		
 <b>FONDI SHOQËTAR I ZHVILLIMIT</b>					
<b>KONSULENTI INXHINIERIK</b> Nr. Licencës: N.5221/16  <b>ILLYRIAN CONSULTING ENGINEERS</b> Adresa: Rr. "Sami Frashëri", Pallat "Hogea", Katë 11, Tiranë, SHQIPËRI Tel/Fax: +355 4 200 972, Email: <a href="mailto:info@ice.al">info@ice.al</a> , <a href="http://www.ice.al">www.ice.al</a>					
Përgatiti:	Pozicioni	Emri	Nr. Licencës	Firma	
	Arkitekt	Edmond MANAHASA	A.0903/2		
	Ing. Strukturist	Anila SPAHIU	K.1068/4		
	Ing. Strukturist	Aida VOKA	K.1340/2		
	Ing. Hidroteknik	Artjola ZOTAJ	K.3443		
	Ing. Hidroteknik	Silvia GJONAJ			
	Ing. Hidroteknik	Anzhela BICI	K.3452		
	Ing. Elektrik	Enis HAVERIKU	E.1450		
	Ing. Elektrik	Ilber PUCI			
	Ing. Mekanik	Marsel PYLLA	M.1288/1		
Kontrolloi:	Ing. Mekanik	Besnik KARAJ	M.0256/2		
	Koordinator Projekti	Abdurrahman SPAHIU	K.1571/5		
	Ing. Strukturist	Taulant KARRIQI	K.1547/6		
	Ing. Elektrik	Emira BERISHA	E.0550/4		
Miratoi:	Drejues Projekti	Olset HAXHIU	K.1619/5		
<b>TITULLI I PROJEKTIT</b> <b>INVESTIME PILOT PËR TRANSFORMIMIN E INFRASTRUKTURËS SË SHËRBIEMEVE DHE RRIJTJES SË STANDARDIT TË JETËS NË KOMUNITET</b> <b>Objekti: Ndërrhyrje për rikonstrukcionin e spitalit të Peqinit dhe ndryshim i pjesshëm i funksionit të tij</b>					
<b>EMRI I DOKUMENTIT</b> <b>PLANVENDOSJA E KAMERAVE, PRIZAVE TË INTERNETIT, RRJETI I DEDEKTIMIT TË ZJARRIT, AKSES KONTROLL DHE KOMUNIKIMI ZANOR NË KATIN 2 //PLANVIEW OF CAMERAS, LAN SOCKETS, FIRE DETECTION, ACCESS CONTROL AND VOICE ANOUNCEMENTS FOR 2ND FLOOR</b>					
FAZA E PROJEKTIT	Nr. i Dokumentit	Shkalla	Rishikimi	Përmasa e fletës	Fleta
PROJEKT LEJE	E-01	1:150	00	A1 (841x594mm)	11/15



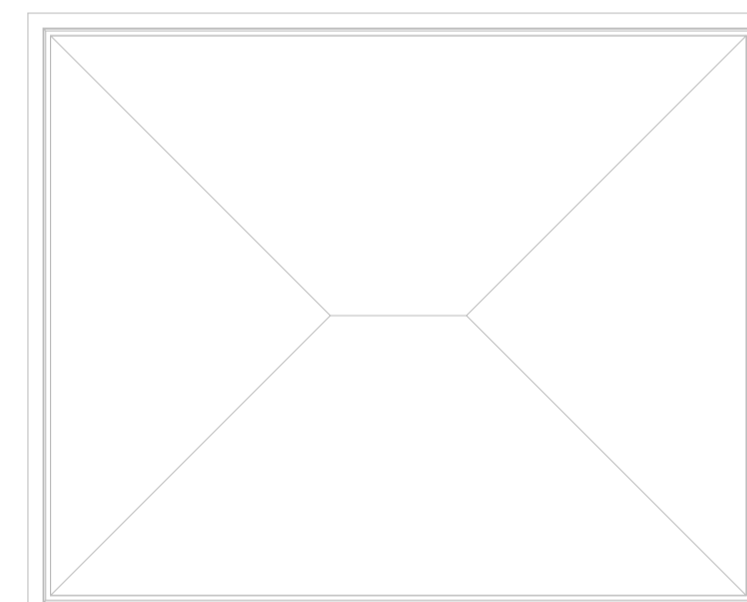
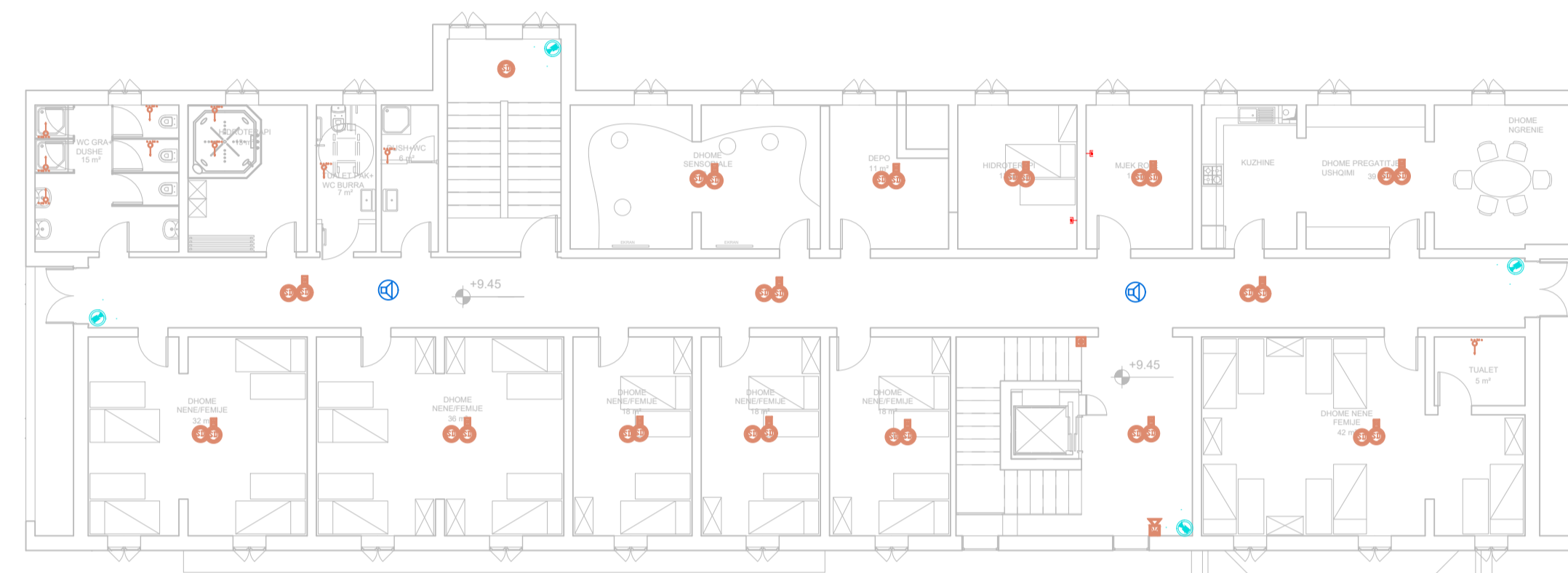



## Legjenda/Legend

-  Kuader elektrik/Electric switchboard
-  Prizë LAN / LAN socket
-  Kamera me IP, tip kupole/IP Camera, type dome
-  Sensor tymi, për montim në tavan betoni/Smoke sensor, for mounting on concrete ceiling
-  Sensor tymi me sensor shtesë, për montim në tavan gipsi/Smoke sensor with additional sensor, for mounting on concrete ceiling
-  Buton alarmi në rast zjarri/Fire protection alarm button
-  Sirenë alarmi/Alarm sirene
-  /Shirit LED/LED strip
-  Lexues aksesit/Access reader
-  Bravë elektrike/Electric lock
-  Çelës fundor për sinjalizim në rast rreziku në nevojore/Limit switch for sharing the risk to central management in case of any risk in WC
-  Boks tavanor /Ceiling-mounted speaker
-  Linjë e të dhënave/LAN data line
-  Linjë e TV/TV Line
-  Linjë e mbrojtjes nga zjarri/Firefighting protection line
-  Linjë KNX për sistemin e menaxhimit të dhomës/KNX line for room management facilities
-  Linjë e sistemit të evakuimit zvon/Audio evacuation system line





00	Tetor 2024	Projekt Lejë			
RISH. NR.	DATA	QËLLIMI I DORËZIMIT	SHENIMI / PËRSHKRIM		
 <b>FONDI SHQIPTAR I ZHVILLIMIT</b>					
<b>KONSULENTI INXHINIERIK</b> Nr. Licencës: N.5221/16  ILLYRIAN CONSULTING ENGINEERS Adresa: Rr. "Sami Frashëri", Pallat "Hogea", Katë 11, Tiranë, SHQIPËRI Tel/Fax: +355 4 200 972, Email: info@ice.al www.ice.al					
Përgatiti:	Pozicioni	Emri	Nr. Licencës	Firma	
	Arkitekt	Edmond MANAHASA	A.0903/2		
	Ing. Strukturist	Anila SPAHIU	K.1068/4		
	Ing. Strukturist	Aida VOKA	K.1340/2		
	Ing. Hidroteknik	Artjola ZOTAJ	K.3443		
	Ing. Hidroteknik	Silvia GJONAJ			
	Ing. Hidroteknik	Anzhela BICI	K.3452		
	Ing. Elektrik	Enis HAVERIKU	E.1450		
	Ing. Elektrik	Ilber PUCI			
	Ing. Mekanik	Marsel PYLLA	M.1288/1		
Kontrolloi:	Ing. Mekanik	Besnik KARAJ	M.0256/2		
	Koordinator Projekti	Abdurrahman SPAHIU	K.1571/5		
	Ing. Strukturist	Taulant KARRIQI	K.1547/6		
	Ing. Elektrik	Emira BERISHA	E.0550/4		
Miratoi:	Drejues Projekti	Oset HAXHIU	K.1619/5		
<b>TITULLI I PROJEKTIT</b> <b>INVESTIME PILOT PËR TRANSFORMIMIN E INFRASTRUKTURËS SË SHËRBIEMEVE DHE RRIJTJES SË STANDARDIT TË JETËS NË KOMUNITET</b> <b>Objekti: Ndërrhyrje për rikonstruksionin e spitalit të Peqinit dhe ndryshim i pjesshëm i funksionit të tij</b>					
<b>EMRI I DOKUMENTIT</b> <b>PLANVENDOSJA E KAMERAVE, PRIZAVE TË INTERNETIT, RRJETI I DEDEKTIMIT TË ZJARRIT, AKSES KONTROLL DHE KOMUNIKIMI ZANOR NË KATIN 3 /PLANVIEW OF CAMERAS, LAN SOCKETS, FIRE DETECTION, ACCESS CONTROL AND VOICE ANNOUNCEMENTS FOR 3RD FLOOR</b>					
FAZA E PROJEKTIT	Nr. i Dokumentit	Shkalla	Rishikimi	Përmasa e fletës	Fleta
PROJEKT LEJE	E-01	1:150	00	A1 (841x594mm)	12/15

### Legjenda/Legend

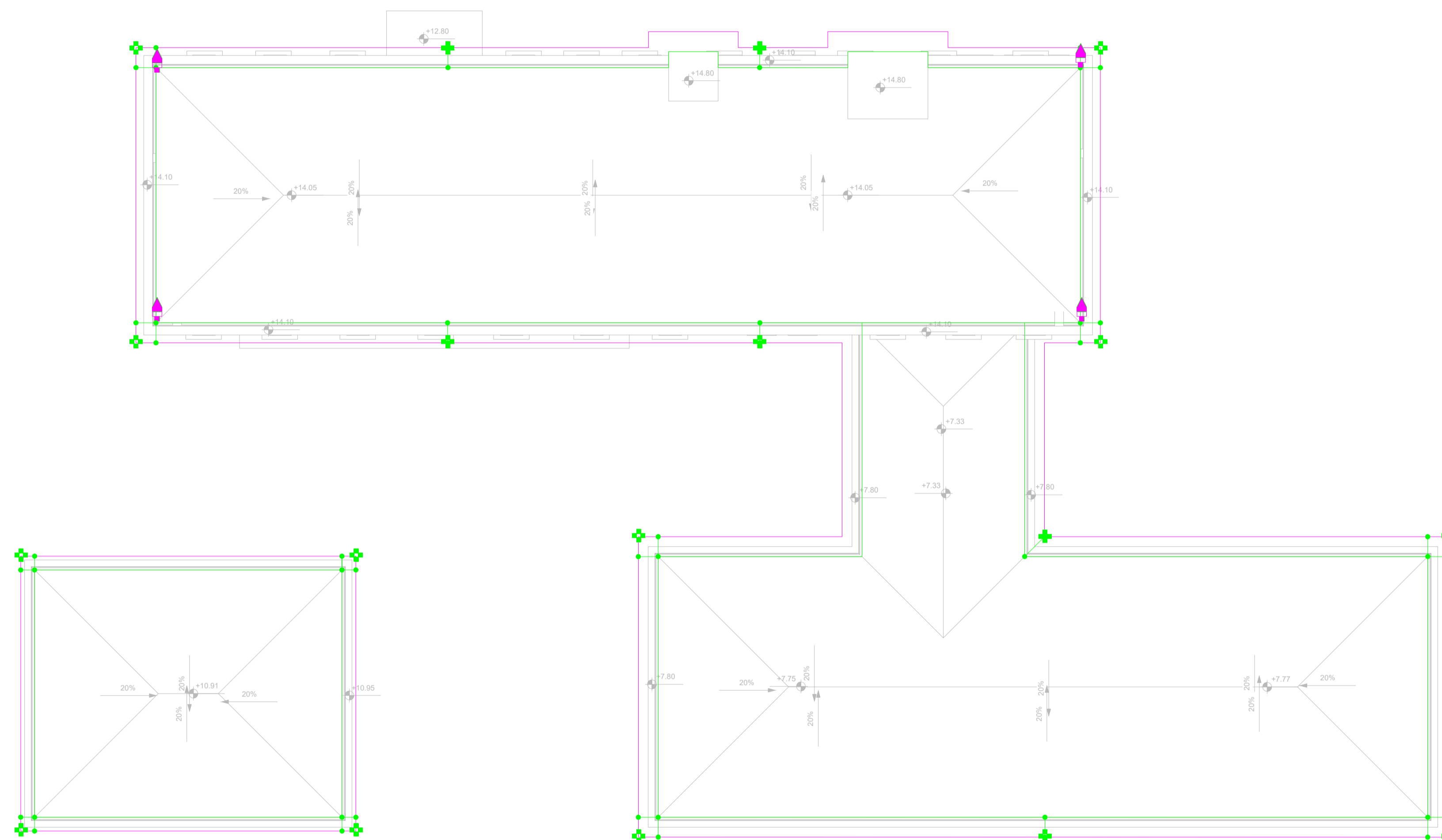
-  Rrufepritis/Lighting rod
-  Rrufepritis, tip ESE, kategoria e IV, pamja në plan/Lighting rod, type ESE, category IV, plan view
-  Elektrode tokëzimi e galvanizuar në të nxehtë, 1.5 m gjatësi, pamja në plan/Hot-dip galvanized earthing electrode, 1.5 m length, plan view
-  Elektrode tokëzimi e galvanizuar në të nxehtë, 1.5 m gjatësi, pamja ballore/Hot-dip galvanized earthing electrode, 1.5 m length, front view
-  Morsetë bashkuese/Connection clamp
-  Shirit tokëzimi i galvanizuar në të nxehtë, 30x3 cm/ Hot-dip galvanized earthing strip, 30x3 cm
-  Linja e rrethit të llogaritjes të zonës së mbulimit të rufepritisve/The circle line of the calculation of the lightning rod coverage area



00	Tetor 2024	Projekt Leje							
RISH. NR.	DATA	QELIMI I DORËZIMIT	SHENIM / PËRSHKRIM						
 <b>FONDI SHQIPTAR I ZHVILLIMIT</b>									
<b>KONSULENTI INXHINIERIK</b>  Nr. Licencës: N.5221/16									
Përgatit:	Pozicioni	Emri	Nr. Licencës	Firma					
	Arkitekt	Edmond MANAHASA	A.0903/2						
	Ing. Strukturist	Anila SPAHIU	K.1068/4						
	Ing. Strukturist	Aida VOKA	K.1340/2						
	Ing. Hidroteknik	Artjola ZOTAJ	K.3443						
	Ing. Hidroteknik	Silvia GJONAJ							
	Ing. Hidroteknik	Anzhela BICI	K.3452						
	Ing. Elektrik	Enis HAVERIKU	E.1450						
	Ing. Elektrik	Ilber PUCI							
	Ing. Mekanik	Marsel PYLLA	M.1288/1						
Kontrollo:	Ing. Mekanik	Besnik KARAJ	M.0256/2						
	Koordinator Projekti	Abdurrahman SPAHIU	K.1571/5						
	Ing. Strukturist	Taulant KARRIQI	K.1547/6						
	Ing. Elektrik	Emira BERISHA	E.0550/4						
Mirator:	Drejues Projekti	Olset HAXHIU	K.1619/5						
<b>TITULLI I PROJEKTIT</b> <b>INVESTIME PILOT PËR TRANSFORMIMIN E INFRASTRUKTURËS SË SHËRBIMEVE DHE RRTJES SË STANDARDIT TË JETËS NË KOMUNITET</b> <b>Objekti: Ndërrhyrje për rikonstrukcionin e spitalit të Peqinit dhe ndryshim i pjesshëm i funksionit të tij</b>									
<b>EMRI I DOKUMENTIT</b> <b>PLANVENDOSJA E RRUFEPRITËSVE, MORSETAVE BASHKUESE, TOKËZIMIT DHE ZONAT E MBULIMIT TË RRUFEPRITËSVE /PLANVIEW OF LIGHTNING RODS, CONNECTING CLAMPS, AND COVERING PROTECTION ZONES OF LIGHTNING ARRESTERS</b>									
FAZA E PROJEKTIT		Nr. i Dokumentit	Shkalla	Rishikimi	Përmasa e fletës	Fleta			
PROJEKT LEJE		E-01	1:150	00	A1 (841x594mm)	13/15			

## Fasada Veriore

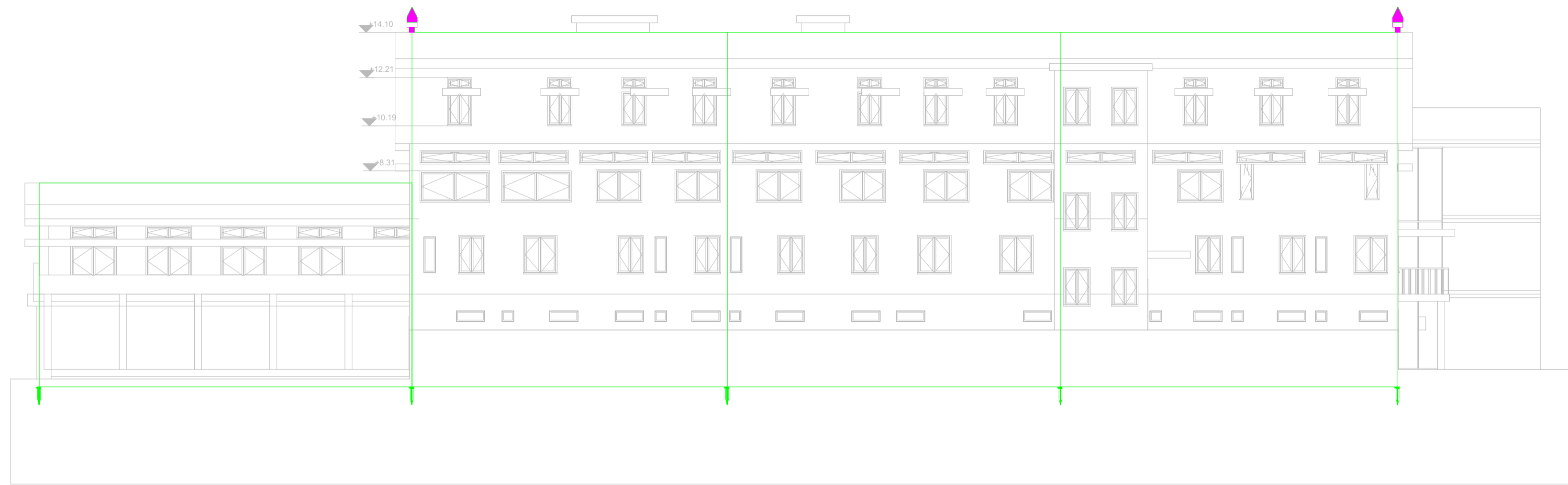

## Objekti i ri

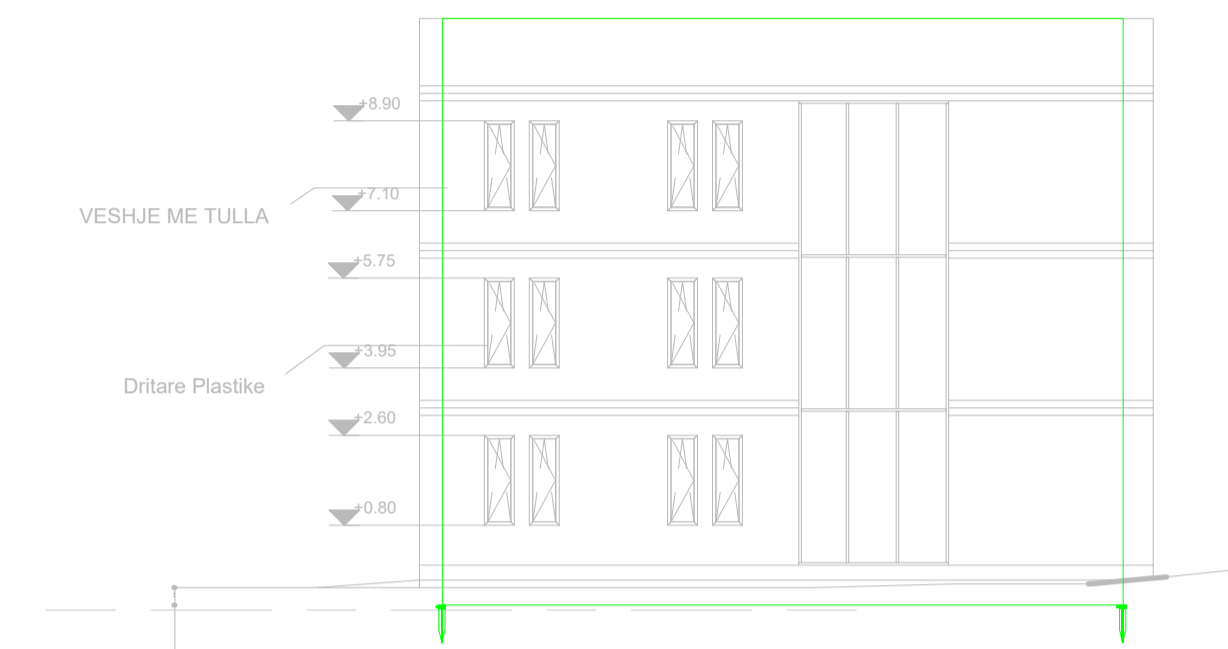

## Fasada Jugore



## Objekti i ri

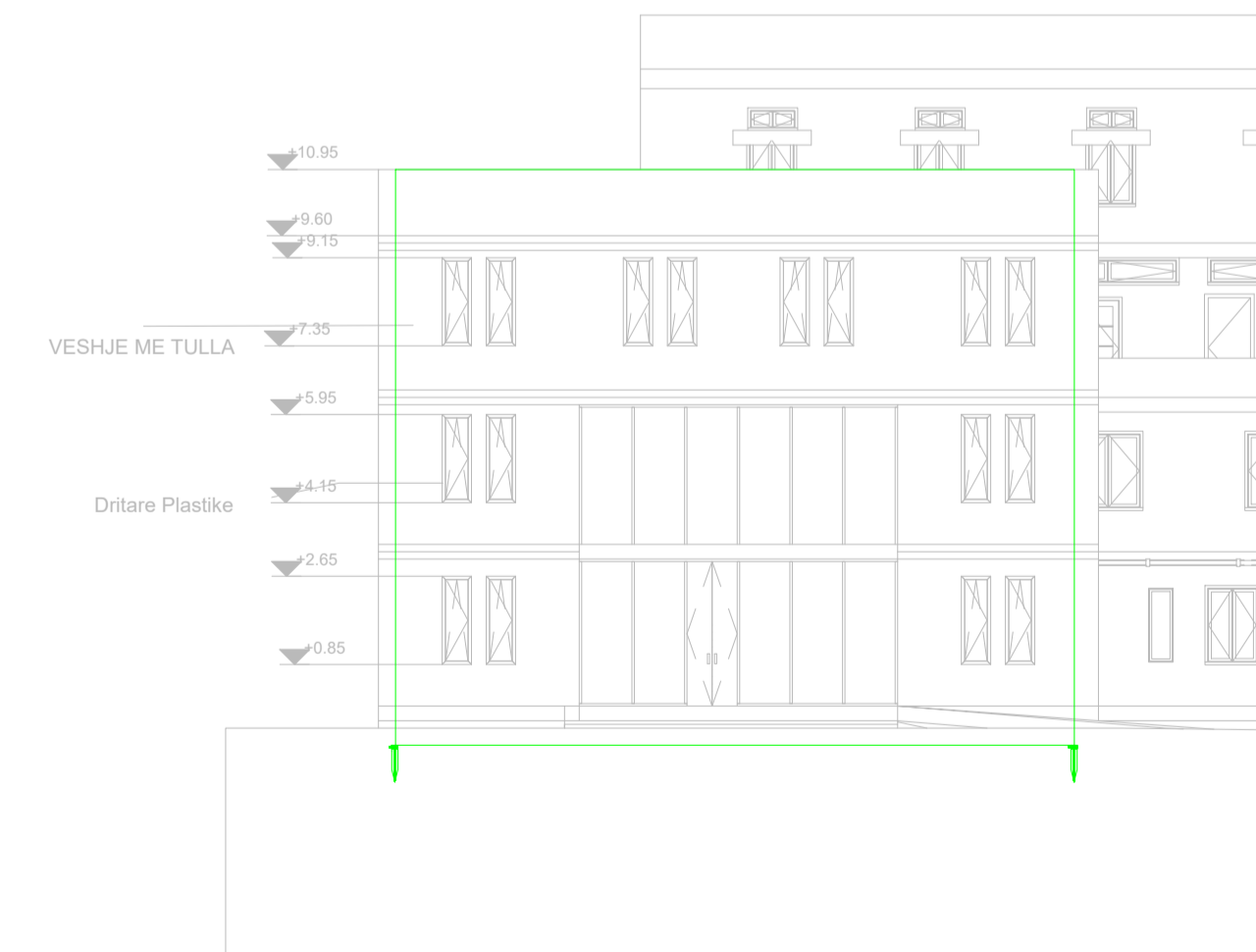

## Legjenda/Legend

- Rrufepritës/Lighting rod
- Rrufepritës, tip ESE, kategoria e IV, pamja në plan/Lighting rod, type ESE, category IV, plan view
- Elektrode tokëzimi e galvanizuar në të nxehtë, 1.5 m gjatësi, pamja në plan/Hot-dip galvanized earthing electrode, 1.5 m length, plan view
- Elektrode tokëzimi e galvanizuar në të nxehtë, 1.5 m gjatësi, pamja ballore/Hot-dip galvanized earthing electrode, 1.5 m length, front view
- Morsetë bashkuese/Connection clamp
- Shirit tokëzimi i galvanizuar në të nxehtë, 30x3 cm/ Hot-dip galvanized earthing strip, 30x3 cm
- Linja e rrethit të llogaritjes të zonës së mbulimit të rufepritësve/The circle line of the calculation of the lightning rod coverage area

00	Tetor 2024	Projekt Lejë																																									
RISH. NR.	DATA	QELIMI I DORËZIMIT	SHENIM / PËRSHKRIM																																								
 <b>FONDI SHOIPTAR I ZHVILLIMIT</b>																																											
<b>KONSULENTI INXHINIERIK</b> Nr. Licencës: N.5221/16  ILLYRIAN CONSULTING ENGINEERS Adresa: Rr. "Sami Frashëri", Pallat "Hogea", Katë 11, Tiranë, SHQIPËRI Tel/Fax: +355 4 390 972; Email: info@ice.al; www.ice.al																																											
Përgatiti:	<table border="1"> <thead> <tr> <th>Pozicioni</th> <th>Emri</th> <th>Nr. Licencës</th> <th>Firma</th> </tr> </thead> <tbody> <tr> <td>Arkitëkt</td> <td>Edmond MANAHASA</td> <td>A.0903/2</td> <td></td> </tr> <tr> <td>Ing. Strukturist</td> <td>Anila SPAHIU</td> <td>K.1068/4</td> <td></td> </tr> <tr> <td>Ing. Strukturist</td> <td>Aida VOKA</td> <td>K.1340/2</td> <td></td> </tr> <tr> <td>Ing. Hidroteknik</td> <td>Artjola ZOTAJ</td> <td>K.3443</td> <td></td> </tr> <tr> <td>Ing. Hidroteknik</td> <td>Silvia GJONAJ</td> <td></td> <td></td> </tr> <tr> <td>Ing. Hidroteknik</td> <td>Anzhela BICI</td> <td>K.3452</td> <td></td> </tr> <tr> <td>Ing. Elektrik</td> <td>Enis HAVERIKU</td> <td>E.1450</td> <td></td> </tr> <tr> <td>Ing. Elektrik</td> <td>Ilber PUCI</td> <td></td> <td></td> </tr> <tr> <td>Ing. Mekanik</td> <td>Marsel PYLLA</td> <td>M.1288/1</td> <td></td> </tr> </tbody> </table>	Pozicioni	Emri	Nr. Licencës	Firma	Arkitëkt	Edmond MANAHASA	A.0903/2		Ing. Strukturist	Anila SPAHIU	K.1068/4		Ing. Strukturist	Aida VOKA	K.1340/2		Ing. Hidroteknik	Artjola ZOTAJ	K.3443		Ing. Hidroteknik	Silvia GJONAJ			Ing. Hidroteknik	Anzhela BICI	K.3452		Ing. Elektrik	Enis HAVERIKU	E.1450		Ing. Elektrik	Ilber PUCI			Ing. Mekanik	Marsel PYLLA	M.1288/1			
Pozicioni	Emri	Nr. Licencës	Firma																																								
Arkitëkt	Edmond MANAHASA	A.0903/2																																									
Ing. Strukturist	Anila SPAHIU	K.1068/4																																									
Ing. Strukturist	Aida VOKA	K.1340/2																																									
Ing. Hidroteknik	Artjola ZOTAJ	K.3443																																									
Ing. Hidroteknik	Silvia GJONAJ																																										
Ing. Hidroteknik	Anzhela BICI	K.3452																																									
Ing. Elektrik	Enis HAVERIKU	E.1450																																									
Ing. Elektrik	Ilber PUCI																																										
Ing. Mekanik	Marsel PYLLA	M.1288/1																																									
Kontrolloi:	<table border="1"> <tbody> <tr> <td>Ing. Mekanik</td> <td>Besnik KARAJ</td> <td>M.0256/2</td> <td></td> </tr> <tr> <td>Koordinator Projekti</td> <td>Abdurrahman SPAHIU</td> <td>K.1571/5</td> <td></td> </tr> <tr> <td>Ing. Strukturist</td> <td>Taulant KARRIQI</td> <td>K.1547/6</td> <td></td> </tr> <tr> <td>Ing. Elektrik</td> <td>Emira BERISHA</td> <td>E.0550/4</td> <td></td> </tr> </tbody> </table>	Ing. Mekanik	Besnik KARAJ	M.0256/2		Koordinator Projekti	Abdurrahman SPAHIU	K.1571/5		Ing. Strukturist	Taulant KARRIQI	K.1547/6		Ing. Elektrik	Emira BERISHA	E.0550/4																											
Ing. Mekanik	Besnik KARAJ	M.0256/2																																									
Koordinator Projekti	Abdurrahman SPAHIU	K.1571/5																																									
Ing. Strukturist	Taulant KARRIQI	K.1547/6																																									
Ing. Elektrik	Emira BERISHA	E.0550/4																																									
Miratoi:	Drejues Projekti	Olset HAXHIU	K.1619/5																																								
<b>TITULLI I PROJEKTIT</b> <b>INVESTIME PILOT PËR TRANSFORMIMIN E INFRASTRUKTURËS SË SHËRBIMEVE DHE RRRITJES SË STANDARDIT TË JETËS NË KOMUNITET</b> <b>Objekti: Ndërhyrje për rikonstrukcionin e spitalit të Peqinit dhe ndryshim i pjesshëm i funksionit të tij</b>																																											
<b>EMRI I DOKUMENTIT</b> <b>PLANVENDOSJA E RRUFEPRITËSVE, MORSETAVE BASHKUESE, TOKËZIMIT DHE ZONAT E MBULIMIT TË RRUFEPRITËSVE /PLANVIEW OF LIGHTNING RODS, CONNECTING CLAMPS, AND COVERING PROTECTION ZONES OF LIGHTNING ARRESTERS</b>																																											
<table border="1"> <thead> <tr> <th>FAZA E PROJEKTIT</th> <th>Nr. i Dokumentit</th> <th>Shkalla</th> <th>Rishikimi</th> <th>Përmasa e fletës</th> <th>Fleta</th> </tr> </thead> <tbody> <tr> <td>PROJEKT LEJË</td> <td>E-01</td> <td>1:150</td> <td>00</td> <td>A1 (841x594mm)</td> <td>14/15</td> </tr> </tbody> </table>				FAZA E PROJEKTIT	Nr. i Dokumentit	Shkalla	Rishikimi	Përmasa e fletës	Fleta	PROJEKT LEJË	E-01	1:150	00	A1 (841x594mm)	14/15																												
FAZA E PROJEKTIT	Nr. i Dokumentit	Shkalla	Rishikimi	Përmasa e fletës	Fleta																																						
PROJEKT LEJË	E-01	1:150	00	A1 (841x594mm)	14/15																																						

### Fasada Perendimore

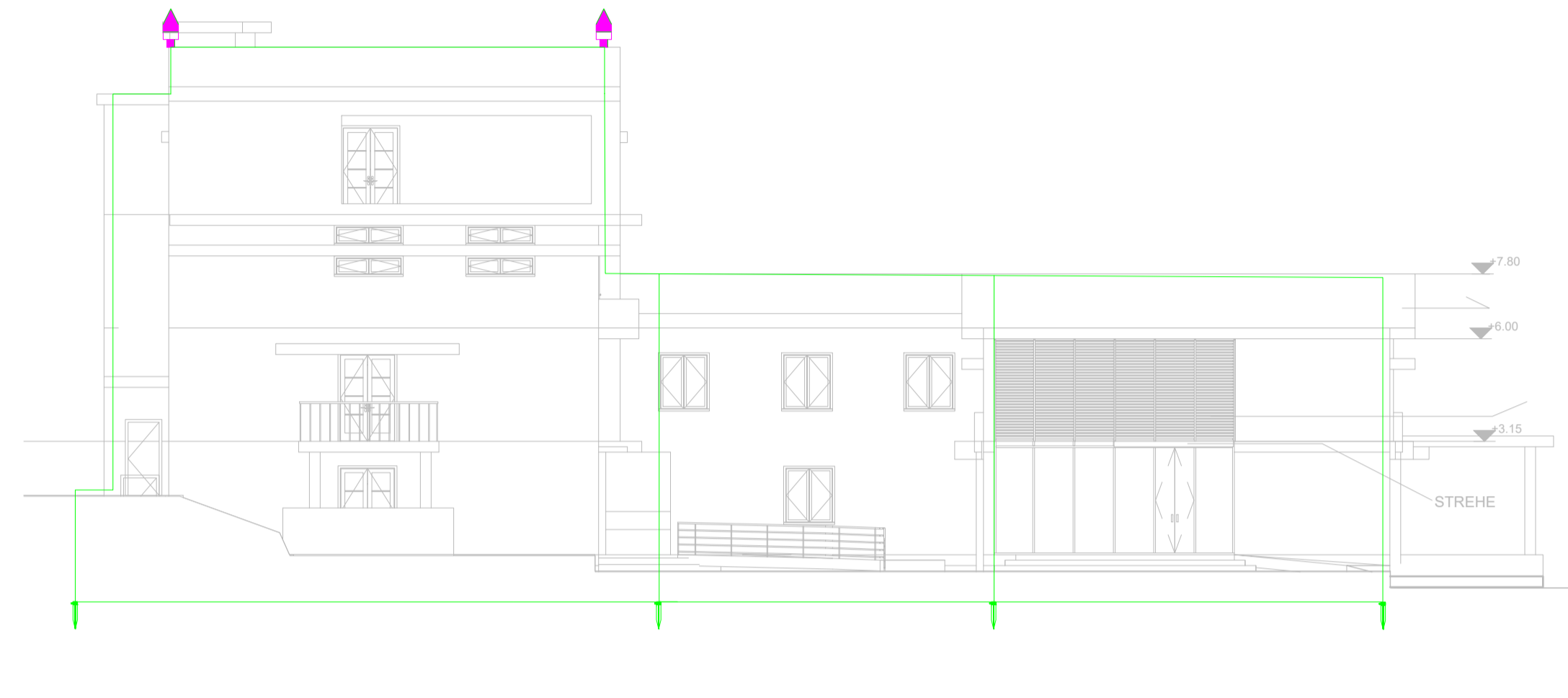

### Objekti i ri

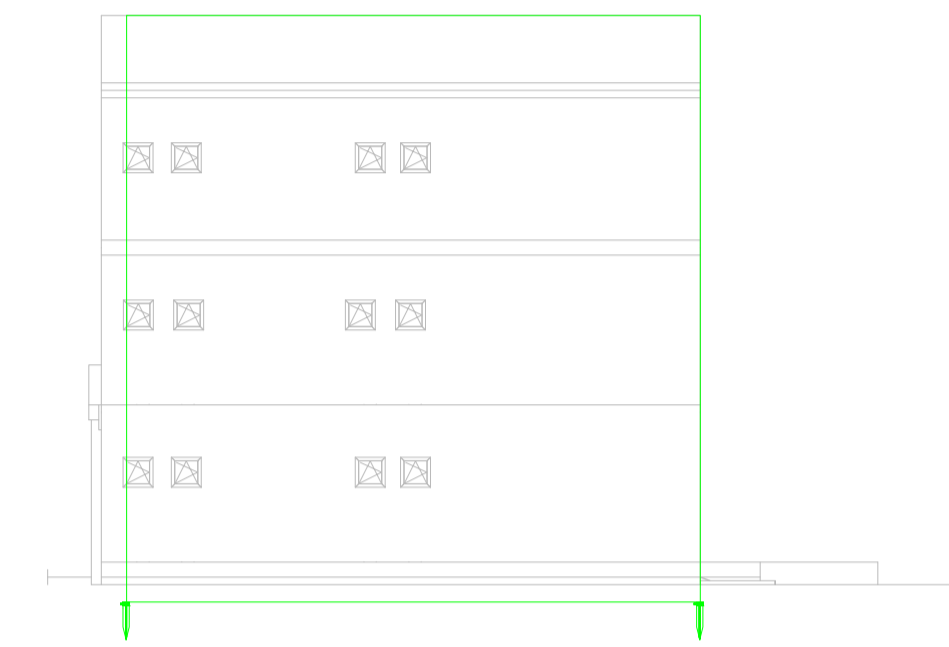

### Fasada Lindore

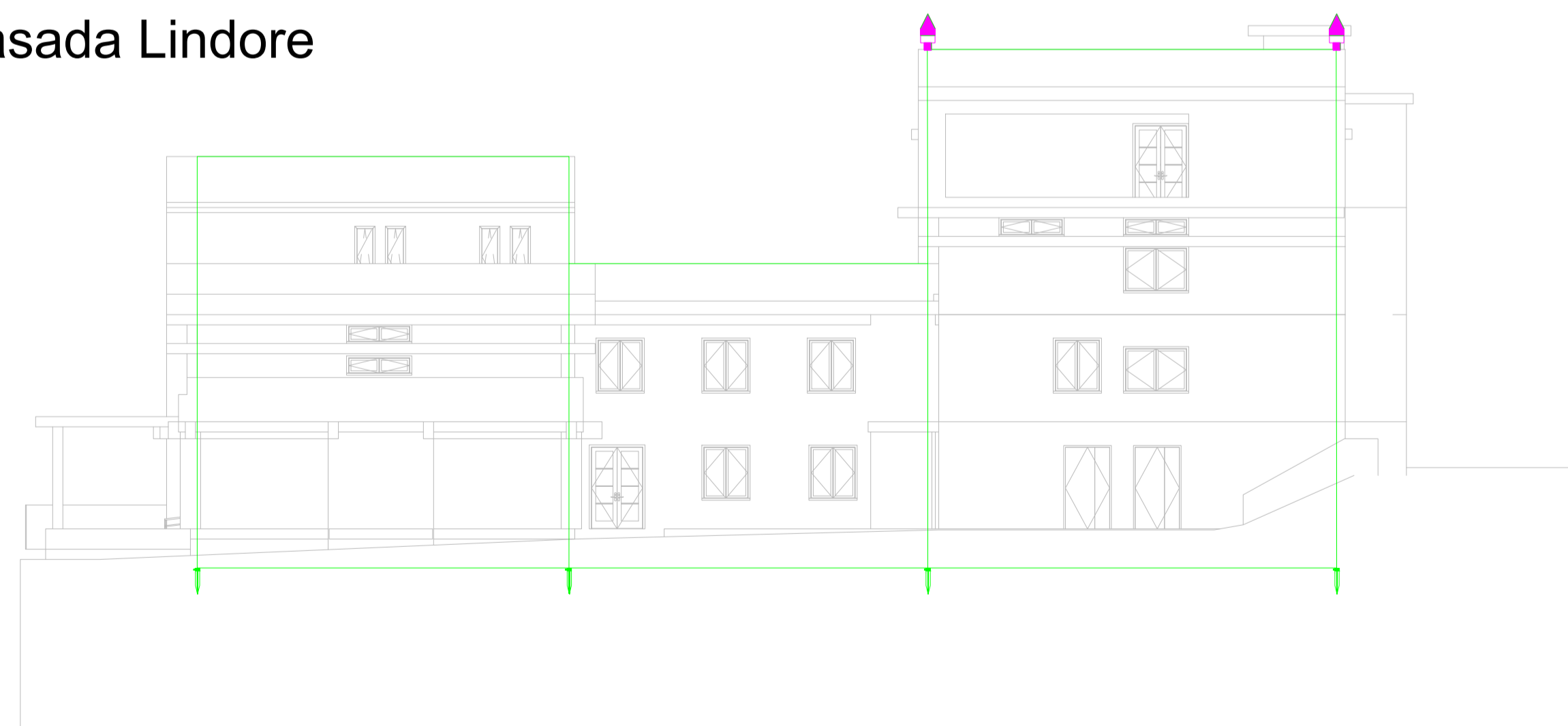

### Objekti i ri

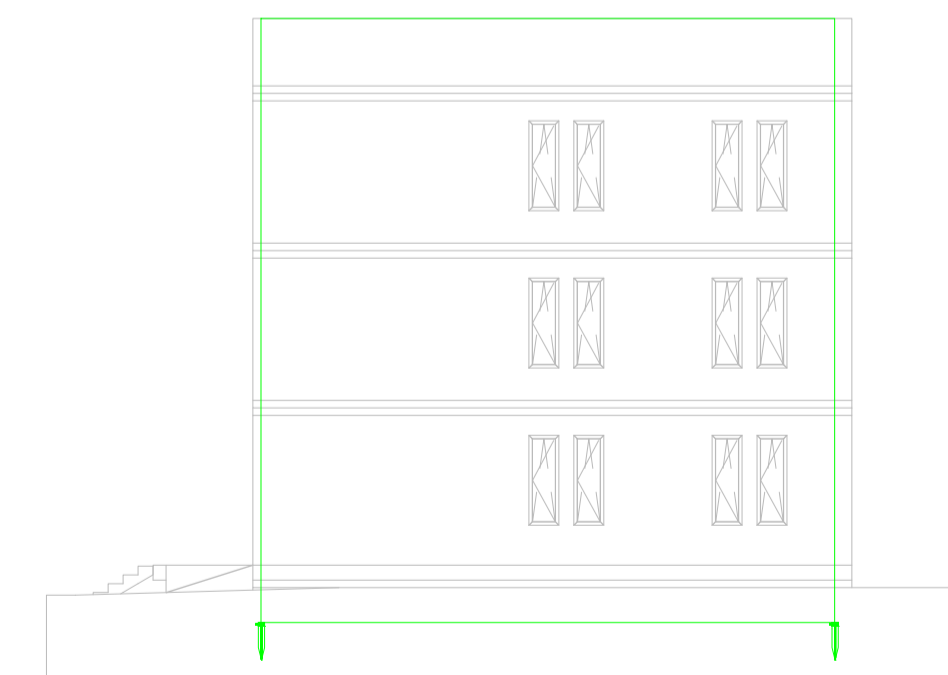

### Legjenda/Legend

- Rrufepritës/Lighting rod
- Rrufepritës, tip ESE, kategoria e IV, pamja në plan/Lighting rod, type ESE, category IV, plan view
- Elektrode tokëzimi e galvanizuar në të nxehtë, 1.5 m gjatësi, pamja në plan/Hot-dip galvanized earthing electrode, 1.5 m length, plan view
- Elektrode tokëzimi e galvanizuar në të nxehtë, 1.5 m gjatësi, pamja ballore/Hot-dip galvanized earthing electrode, 1.5 m length, front view
- Morsetë bashkuese/Connection clamp
- Shirit tokëzimi i galvanizuar në të nxehtë, 30x3 cm/ Hot-dip galvanized earthing strip, 30x3 cm
- Linja e rrethit të llogaritjes të zonës së mbulimit të rufepritësve/The circle line of the calculation of the lightning rod coverage area

00	Tetor 2024	Projekt Lejë			
RISH. NR.	DATA	QËLLIMI I DORËZIMIT	SHENIM / PËRSHKRIM		
<b>KONSULENTI INXHINIERIK</b> Nr. Licencës: N.5221/16  Adresa: Rr. "Sami Frashëri", Pallat "Hera", Katë 11, Tiranë, SHQIPËRI Tel/Fax: +355 4 200 972; Email: info@ice.al; www.ice.al					
Përgatiti:	Pozicioni	Emri	Nr. Licencës	Firma	
	Arkitëkt	Edmond MANAHASA	A.0903/2		
	Ing. Strukturist	Anila SPAHIU	K.1068/4		
	Ing. Strukturist	Aida VOKA	K.1340/2		
	Ing. Hidroteknik	Artjola ZOTAJ	K.3443		
	Ing. Hidroteknik	Silvia GJONAJ			
	Ing. Hidroteknik	Anzhela BICI	K.3452		
	Ing. Elektrik	Enis HAVERIKU	E.1450		
	Ing. Elektrik	Ilber PUCI			
	Ing. Mekanik	Marsel PYLLA	M.1288/1		
Kontrolloi:	Ing. Mekanik	Besnik KARAJ	M.0256/2		
	Koordinator Projekti	Abdurrahman SPAHIU	K.1571/5		
	Ing. Strukturist	Taulant KARRIQI	K.1547/6		
	Ing. Elektrik	Emira BERISHA	E.0550/4		
Miratoi:	Drejues Projekti	Olset HAXHIU	K.1619/5		
TITULLI I PROJEKTIT <b>INVESTIME PILOT PËR TRANSFORMIMIN E INFRASTRUKTURËS SË SHËRMBIMEVE DHE RRRITJES SË STANDARDIT TË JETËS NË KOMUNITET</b> Objekti: Ndërrhyrje për rikonstrukcionin e spitalit të Peqinit dhe ndryshim i pjesshëm i funksionit të tij					
EMRI I DOKUMENTIT <b>PLANVENDOSJA E RRUFEPRITËSVE, MORSETAVE BASHKUESE, TOKËZIMIT DHE ZONAT E MBULIMIT TË RRUFEPRITËSVE /PLANVIEW OF LIGHTNING RODS, CONNECTING CLAMPS, AND COVERING PROTECTION ZONES OF LIGHTNING ARRESTERS</b>					
FAZA E PROJEKTIT	Nr. i Dokumentit	Shkalla	Rishikimi	Përmasa e fletës	Fleta
PROJEKT LEJE	E-01	1:150	00	A1 (841x594mm)	15/15

Shënim/Note: Kuadrot e mëposhtëm janë grupuar dhe të tjerët janë sipas skemës// The following switchboards are grouped, and the remaining one stay as they are shown in the diagram.

Grupimi i Kuadrove/Switchboards grouping	Ekuivalenti/Equivalent
Q3, Q41	NJWSH Kat 0
Q31, Q411	NJWSH Kat 1
Q32, Q412	NJWSH Kat 2
Q1, Q42, Q461	QT Kat 0
Q11, Q43, Q462	QT Kat 1
Q12, Q44, Q463	QT Kat 2
Q13, Q45, Q464	QT Kat 3
Q5, Q47, Q465	Spitali Ditore/Daily Healthcare Service
Q6, Q48, Q466	Qendra Shëndetësore/ Healthcare Center

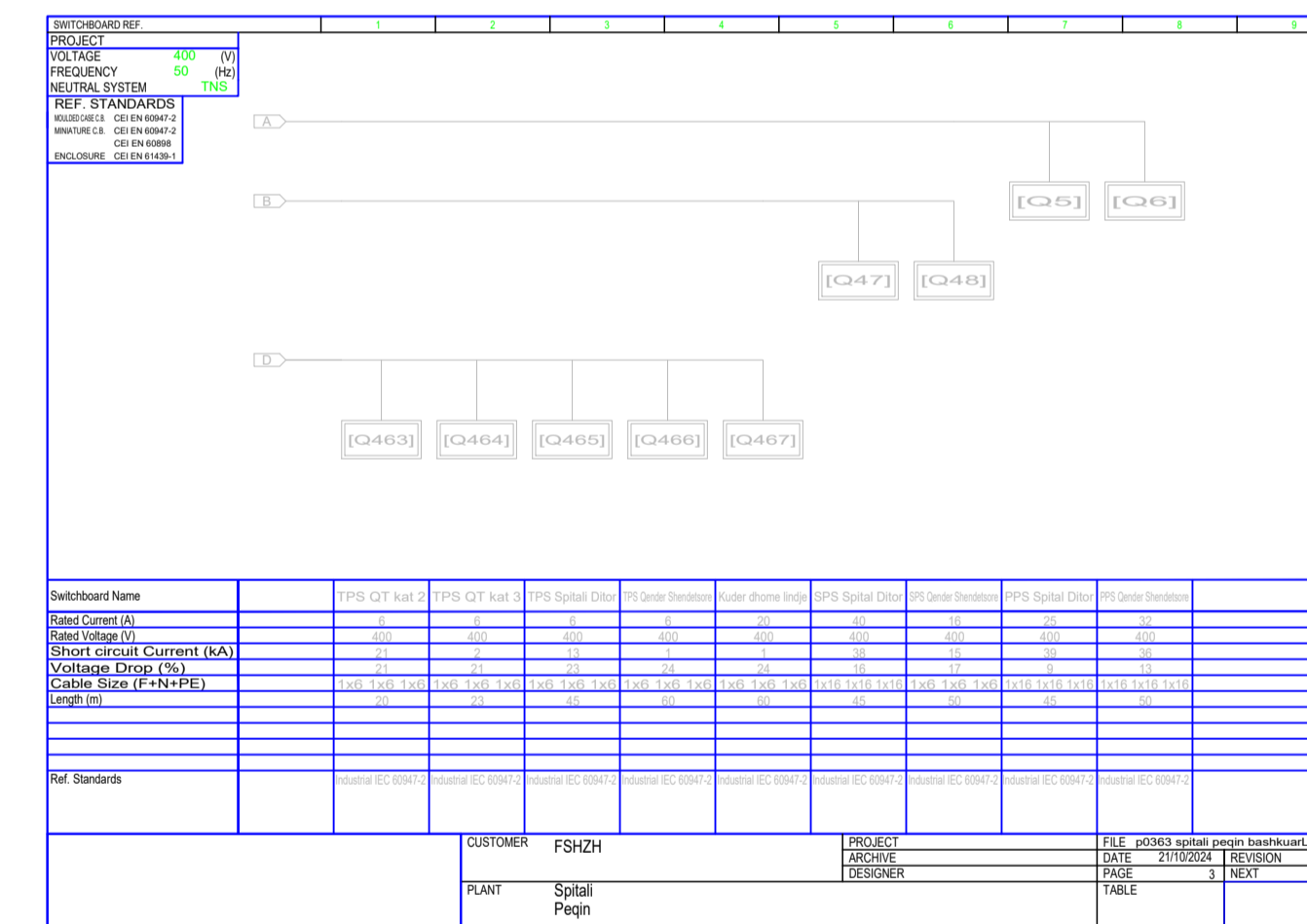
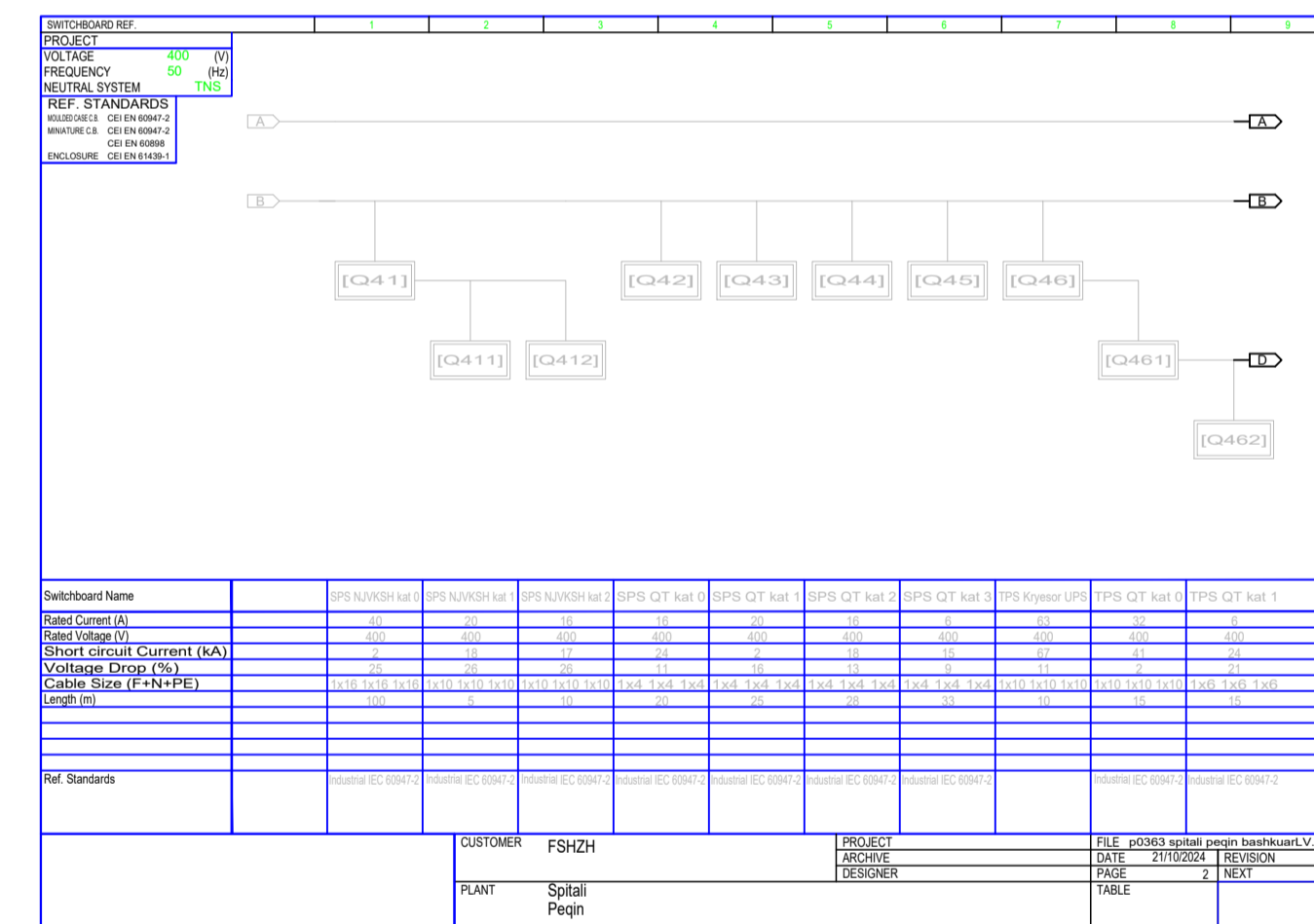
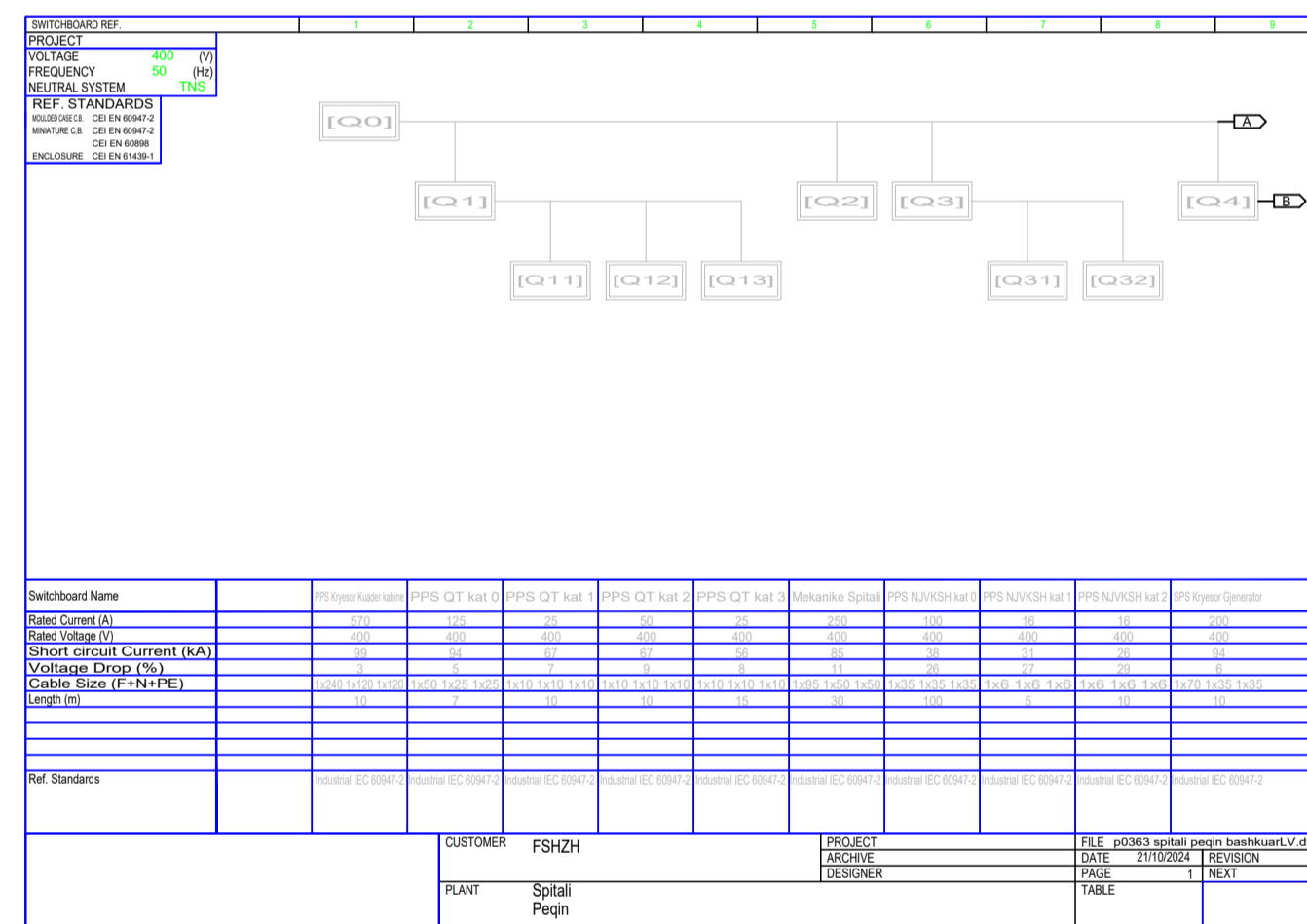

00	Tetor 2024	Projekt Lejë	
RISH NR.	DATA	QELIMI I DOREZIMIT	SHENIM / PERSHKRIM

INVESTITORI

FONDI SHOPTAR I ZHVILLIMIT

KONSULENTI INXHINIERIK

Nr. Licencës: N.5221/16

ILLYRIAN CONSULTING ENGINEERS  
Adresa: Rr. "Sami Frashëri", Pallat "Bjeshkë", Kat 11, Tiranë, SHQIPËRI  
Tel/Fax: +355 4 200 971; Email: info@ice.al  
www.ice.al

Përgatiti:	Emri	Nr. Licencës	Firma
Arkitekt	Edmond MANAHASA	A.0903/2	
Ing. Strukturist	Anila SPAHIU	K.1068/4	
Ing. Strukturist	Alda VOKA	K.1340/2	
Ing. Hidroteknik	Artjola ZOTAJ	K.3443	
Ing. Hidroteknik	Silvia GJONAJ		
Ing. Hidroteknik	Anzhela BICI	K.3452	
Ing. Elektrik	Enis HAVERIKU	E.1450	
Ing. Elektrik	Ilber PUCI		
Ing. Mekanik	Marsel PYLLA	M.1288/1	
Ing. Mekanik	Besnik KARAJ	M.0256/2	
Koordinator Projekti	Abdurrahman SPAHIU	K.1571/5	
Ing. Strukturist	Taulant KARRIQI	K.1547/6	
Ing. Elektrik	Emira BERSHA	E.0550/4	
Drejues Projekti	Olset HAXHIU	K.1619/5	

TITULLI I PROJEKTIT

**INVESTIME PILOT PËR TRANSFORMIMIN E INFRASTRUKTURËS SË SHËRBBIMEVE DHE RRTJES SË STANDARDIT TË JETËS NË KOMUNITET**

Objekti: Ndërrhyrje për rikonstrukcionin e spitalit të Peqinit dhe ndryshim i pjesshëm i funksionit të tij

EMRI I DOKUMENTIT

**SKEMAT ELEKTRIKE TË FURNIZIMIT ME ENERGI ELEKTRIKE DHE MBOJTJES SË PAJISJVE ELEKTRIKE / SINGLE LINE DIAGRAMS OF ELECTRICAL ENERGY SUPPLY AND PROTECTION OF ELECTRICAL EQUIPMENT**

FAZA E PROJEKTIT	Nr. i Dokumentit	Shkalla	Rishikimi	Përmasa e fletës	Fleta
PROJEKT LEJE	E-02	-	00	A1 (841x594mm)	1/10



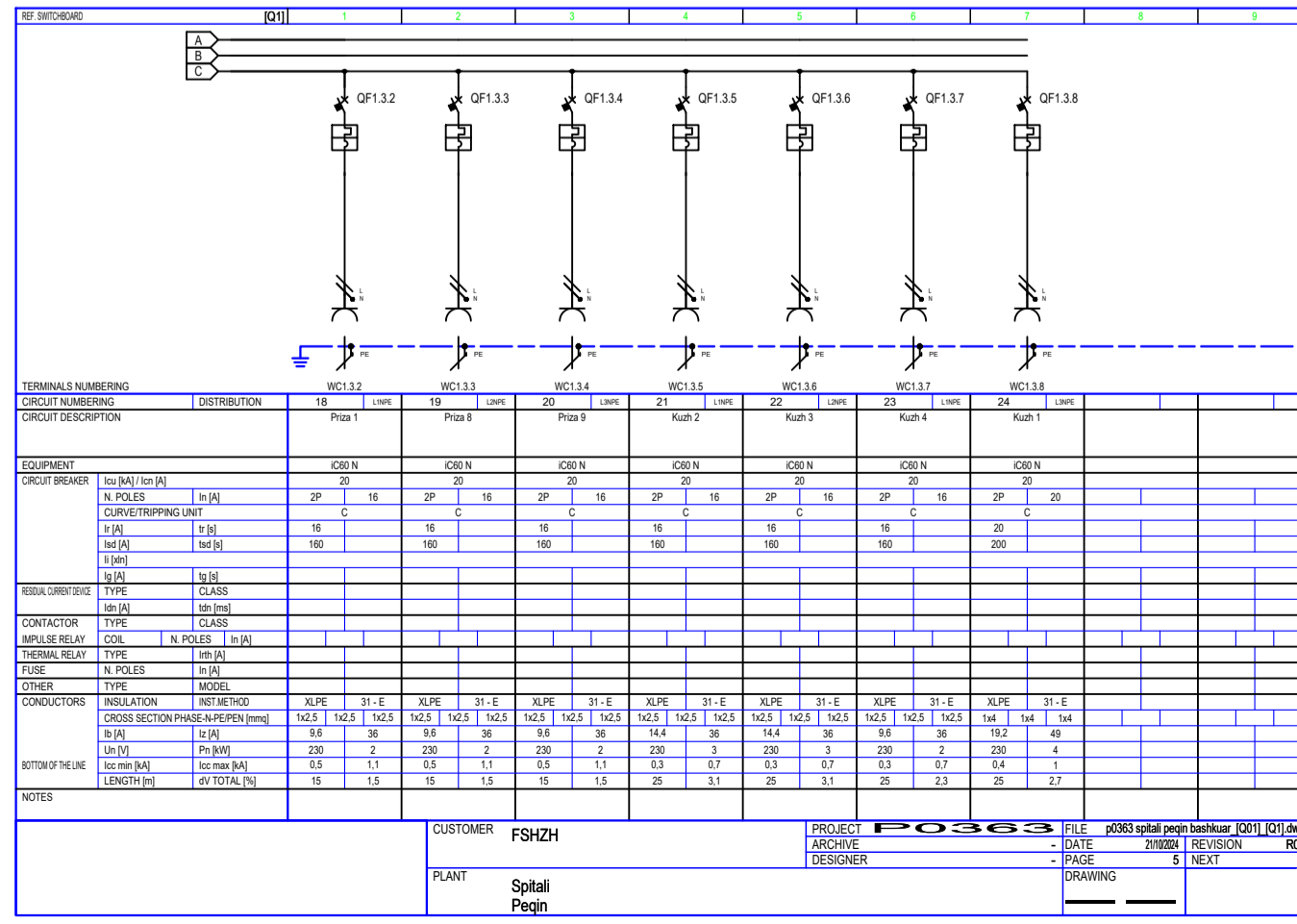
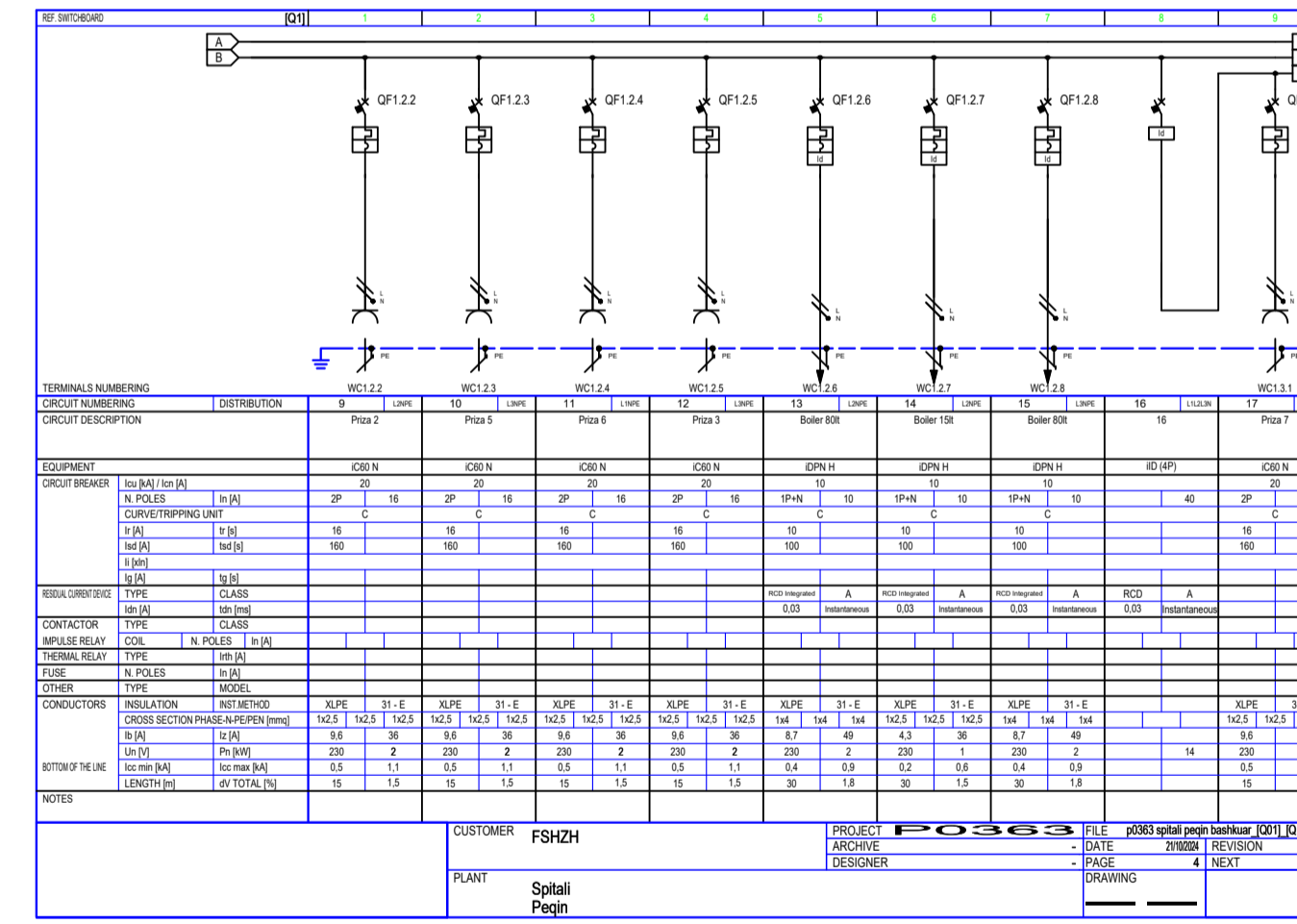
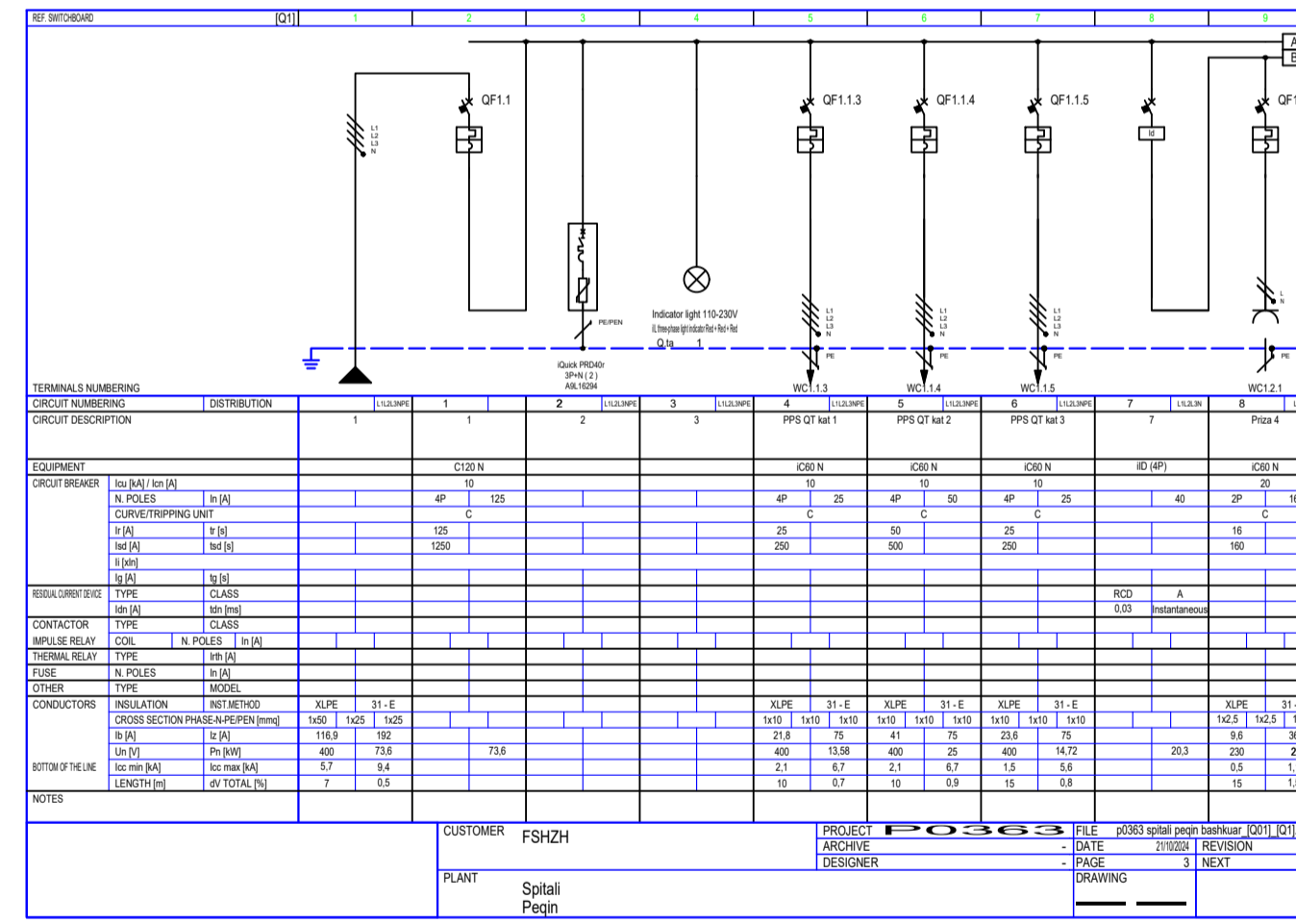
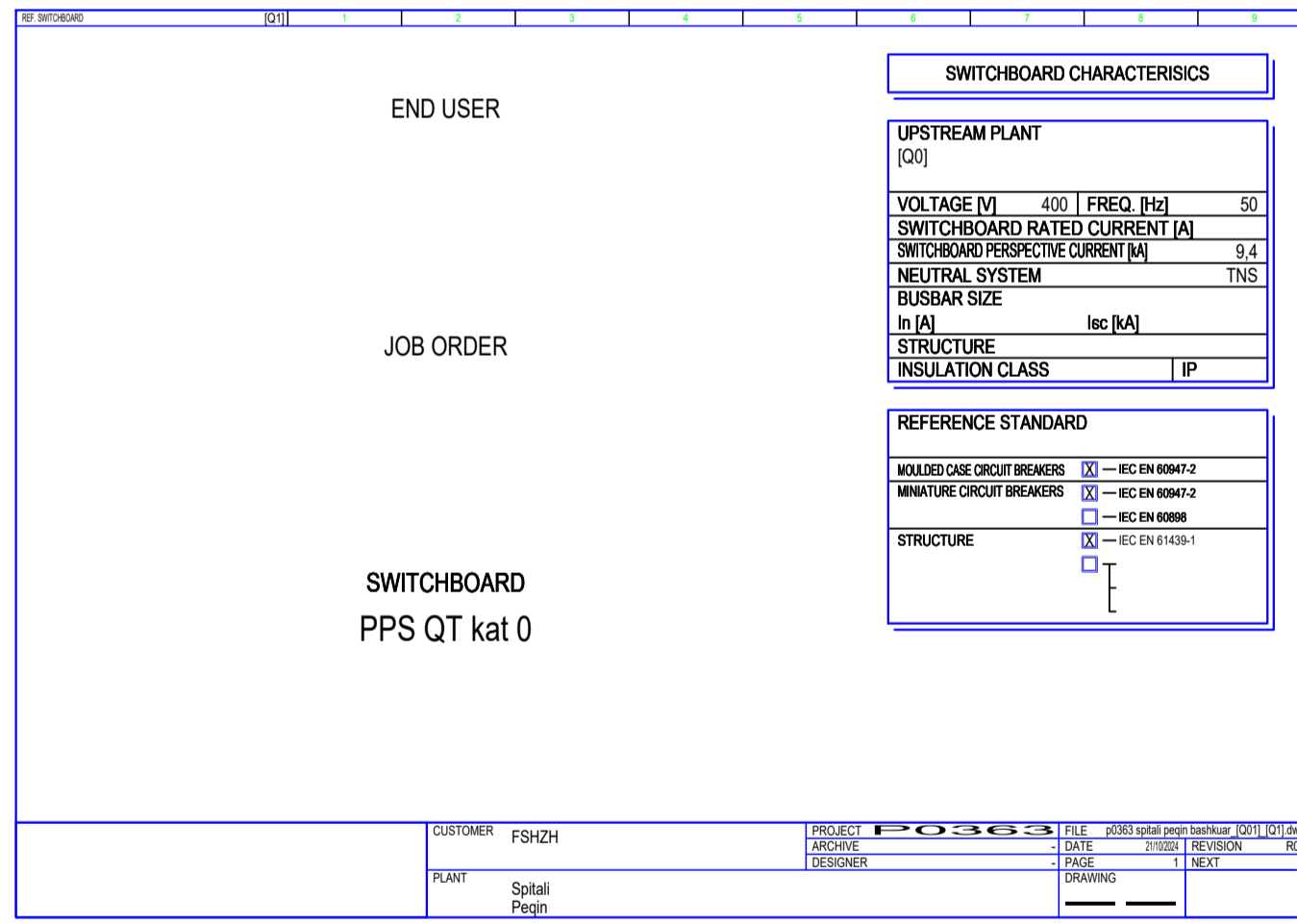
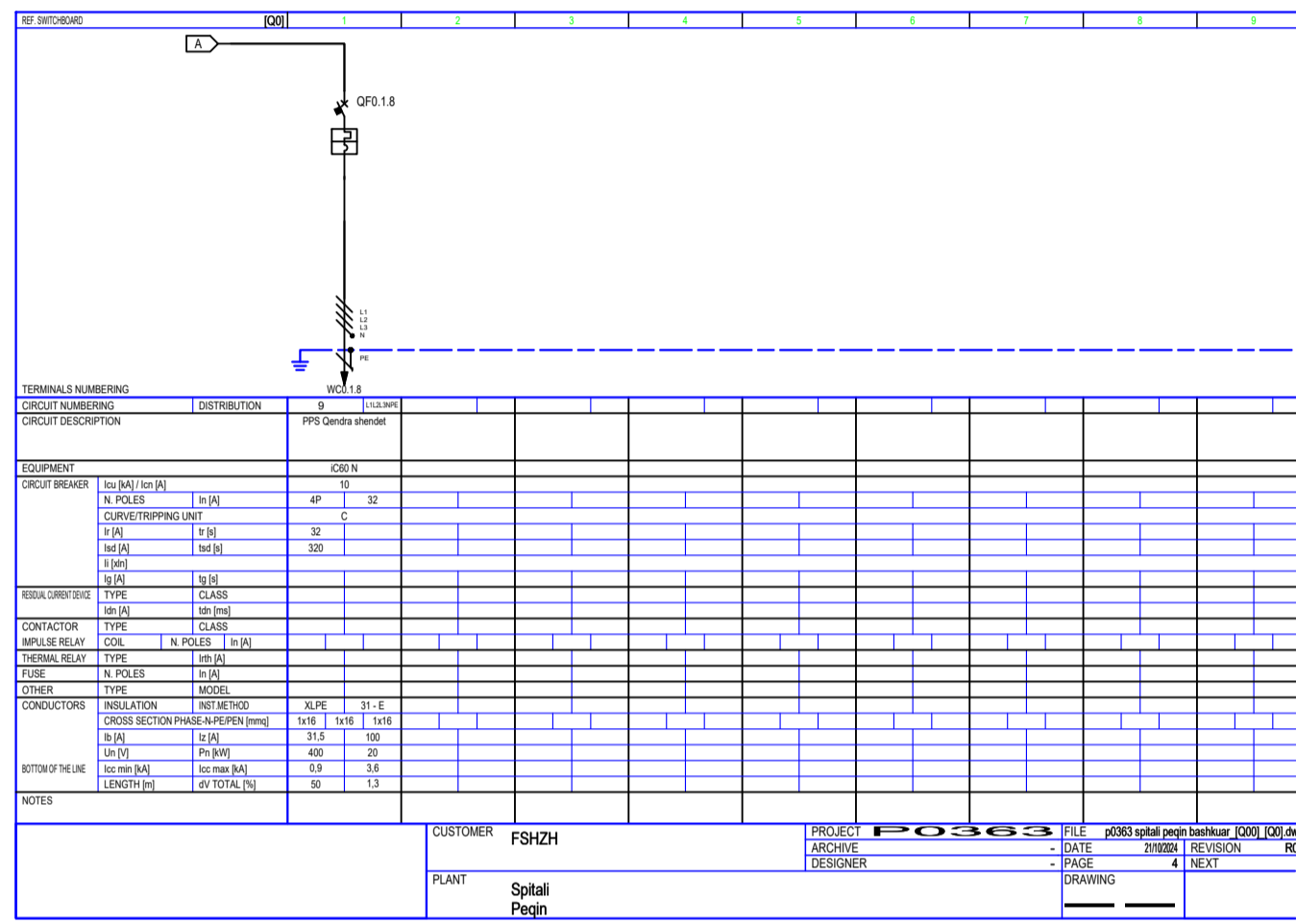
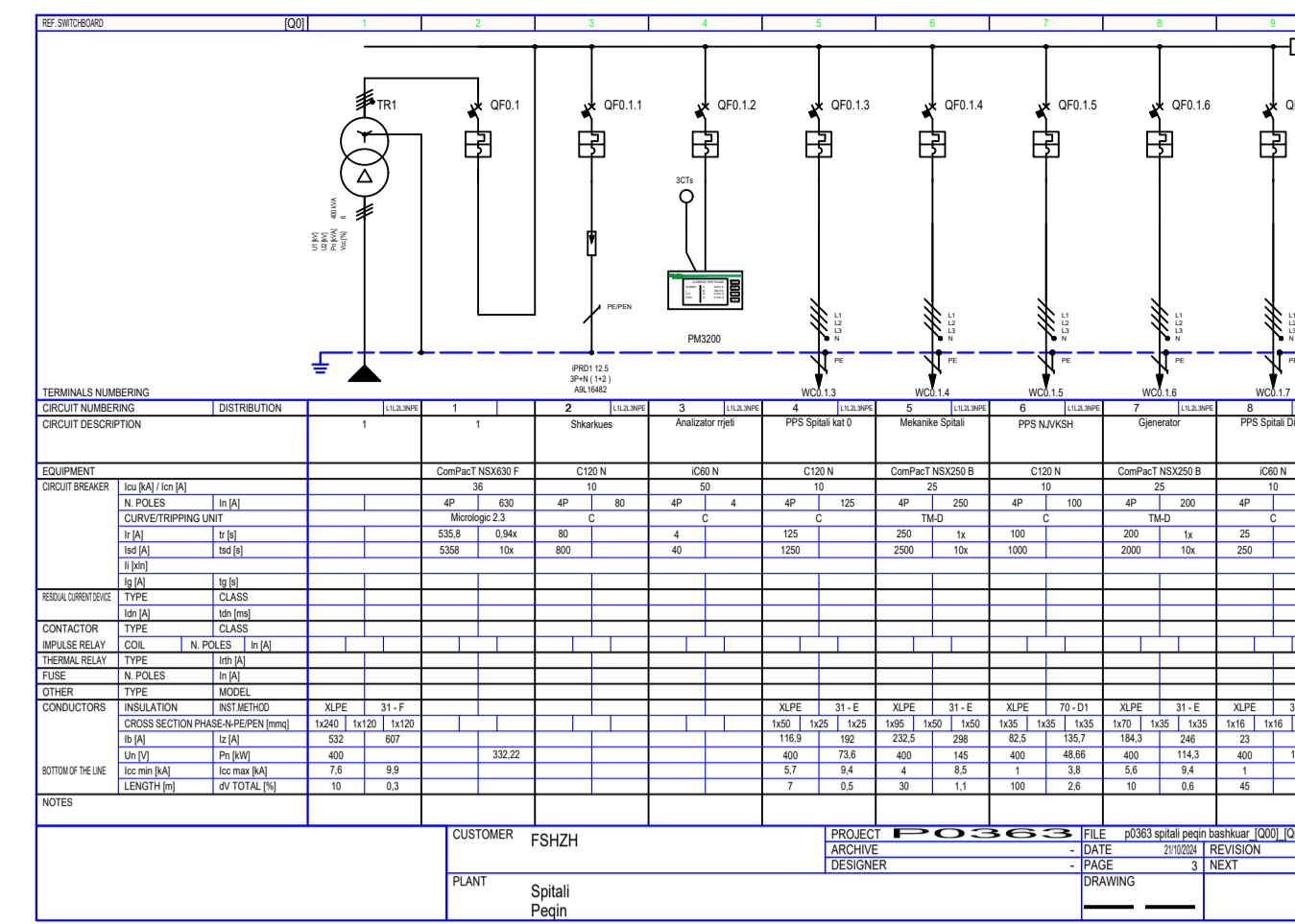
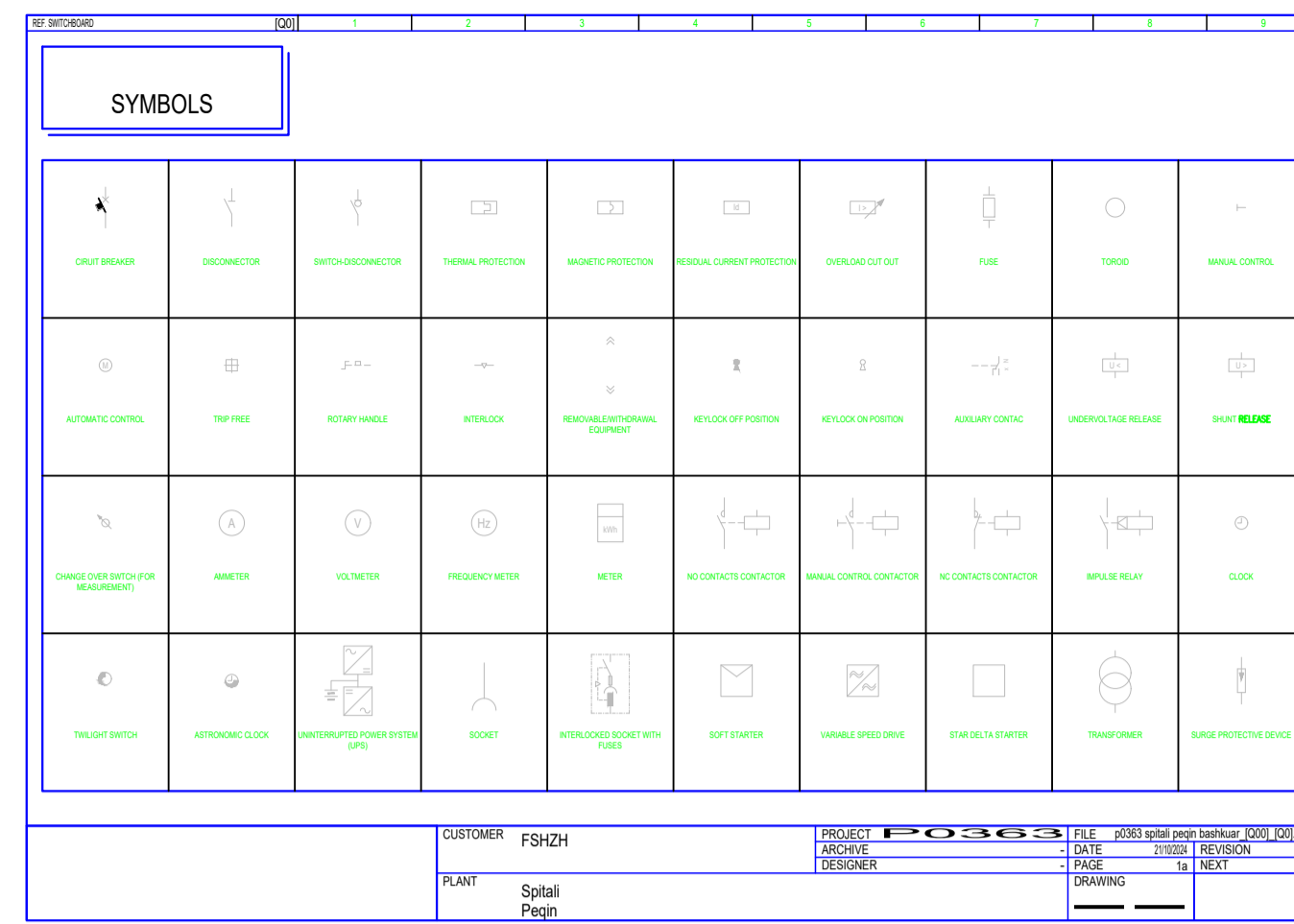
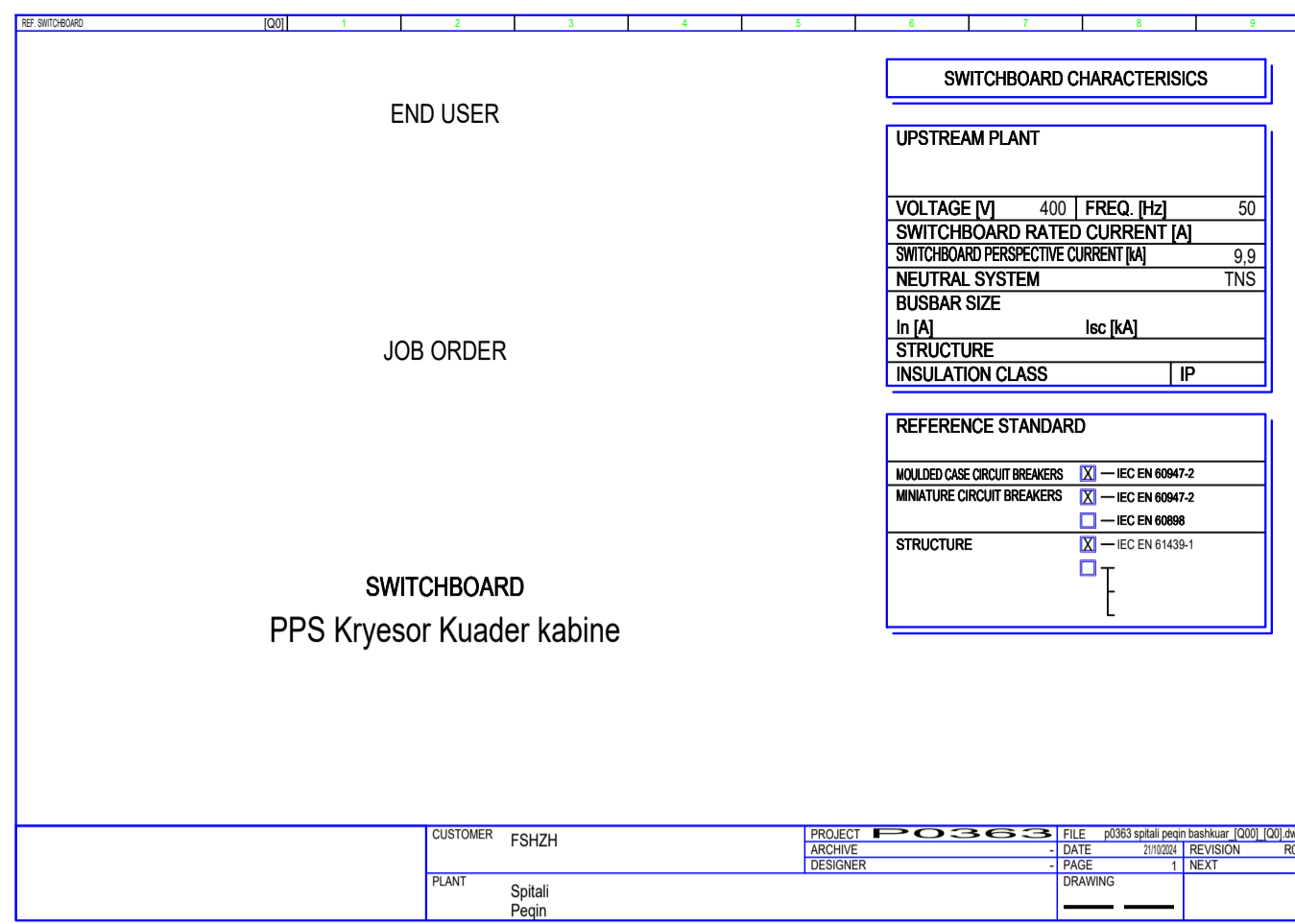

00	Tetor 2024	Projekt Leje	
RISH. NR.	DATA	QELIMI I DOREZIMIT	SHENIM / PERSHKRIM
INVESTITORI			
KONSULENTI INXHINIERIK			
Nr. Licenses: N.5221/16			
Pergatit:	Arktekt	Edmond MANAHASA	A.0903/2
	Ing. Strukturist	Anila SPAHIU	K.1068/4
	Ing. Strukturist	Alda VOKA	K.1340/2
	Ing. Hidroteknik	Artjola ZOTAJ	K.3443
	Ing. Hidroteknik	Silvia GJONAJ	1031/1031/1031
	Ing. Hidroteknik	Anzheta BICI	K.3452
	Ing. Elektrik	Enis HAVERIKU	E.1450
	Ing. Elektrik	Ilber PULCI	
	Ing. Mekanik	Marsel PYLLA	M.1288/1
Kontrolit:	Ing. Mekanik	Besnik KARAJ	M.0256/2
	Koordinator Projekti	Abdurrahman SPAHIU	K.1571/5
	Ing. Strukturist	Taulant KARRIQI	K.1547/6
	Ing. Elektrik	Emira BERSHA	E.0550/4
Mirator:	Drejtesha Projektit	Olset HAXHIU	K.1619/5
TITULLI I PROJEKTIT			
<b>INVESTIME PILOT PER TRANSFORMIMIN E INFRASTRUKTURES SE SHERBIMEVE DHE RRTJES SE STANDARDIT TE JETES NE KOMUNITET</b>			
<b>Objekti: Nderhyrje per rikonstrukcionin e spitalit te Peqinit dhe ndryshim i pjesshem i funksionit te tij</b>			
EMRI I DOKUMENTIT			
<b>SKEMAT ELEKTRIKE TE FURNIZIMIT ME ENERGIJ E ELEKTRIKE DHE MBOJTJES SE PAJISJIVE ELEKTRIKE / SINGLE LINE DIAGRAMS OF ELECTRICAL ENERGY SUPPLY AND PROTECTION OF ELECTRICAL EQUIPMENT</b>			
FAZA E PROJEKTIT	Nr. i Dokumentit	Shkalla	Rishikimi
PROJEKT LEJE	E-02	-	00
			Permasa e fletes
			A1 (841x594mm)
			Fleta
			2/10

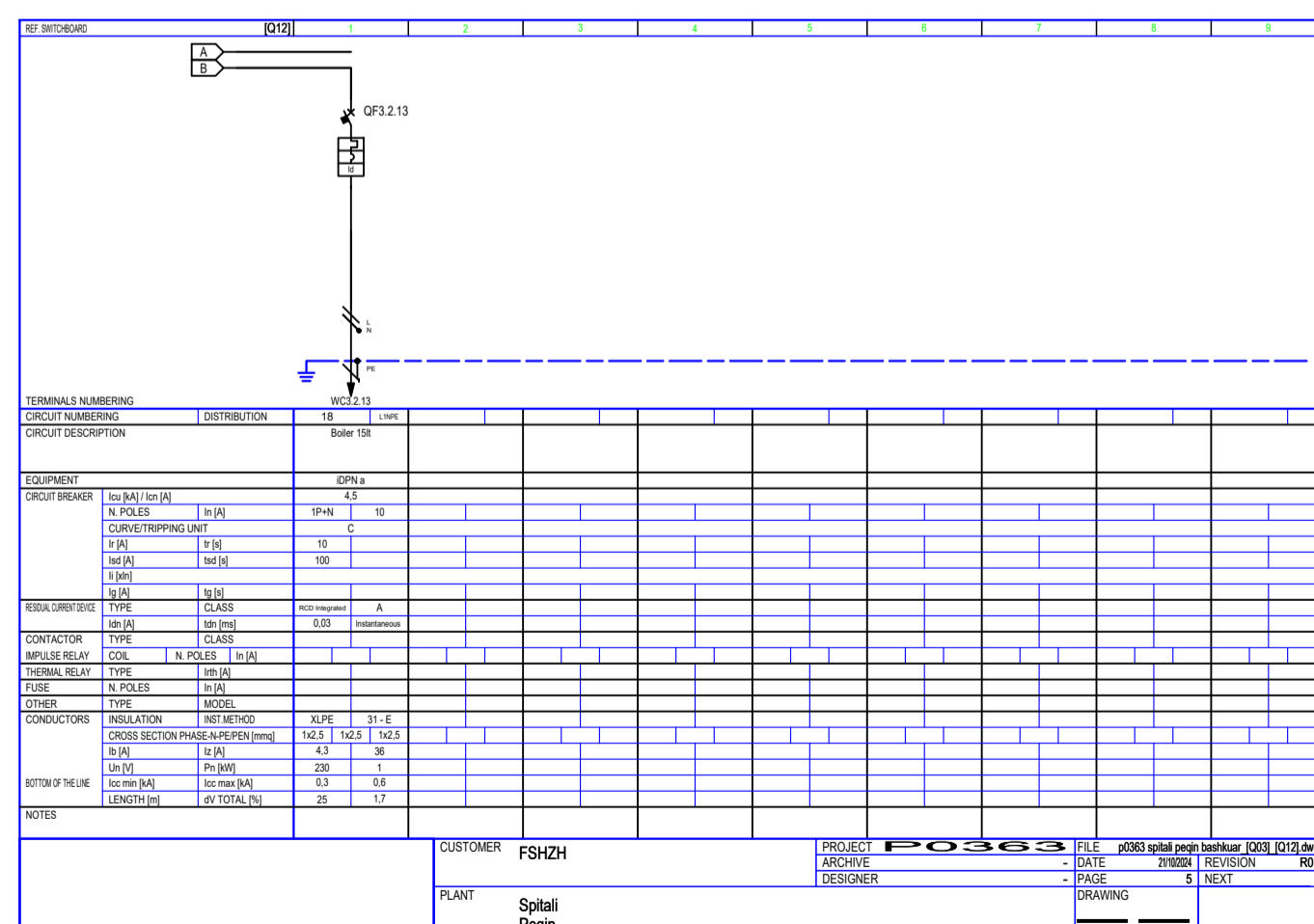
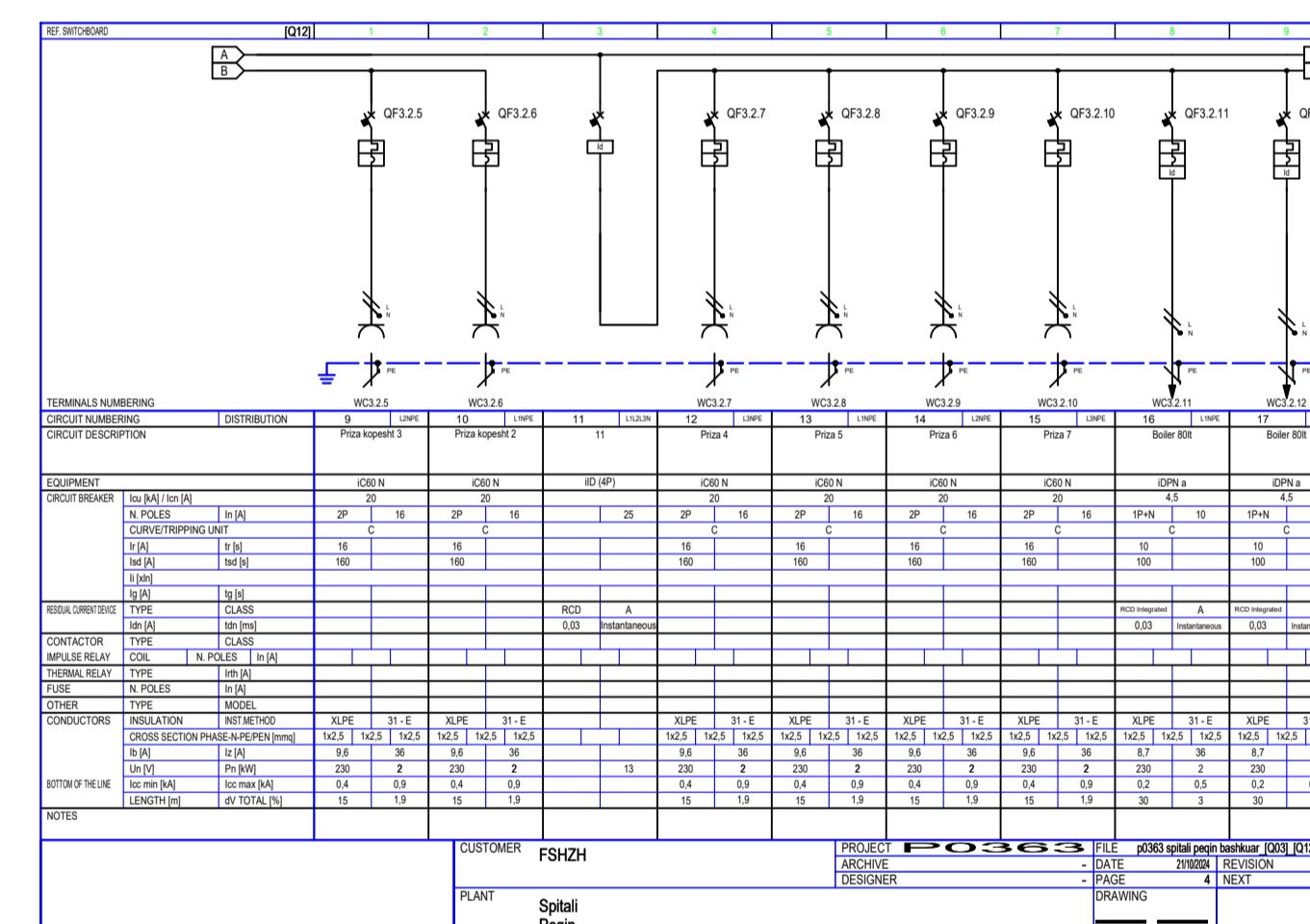
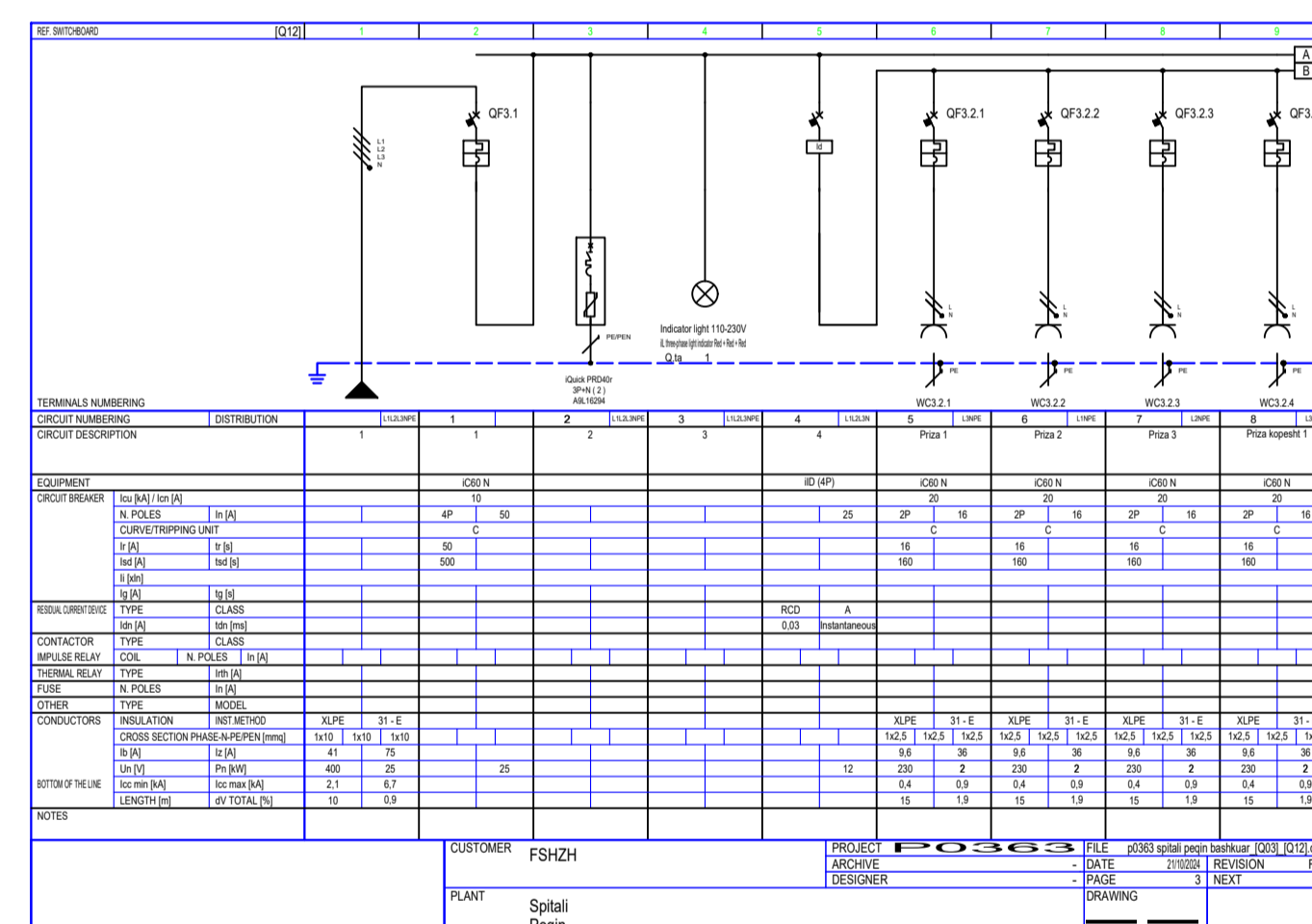
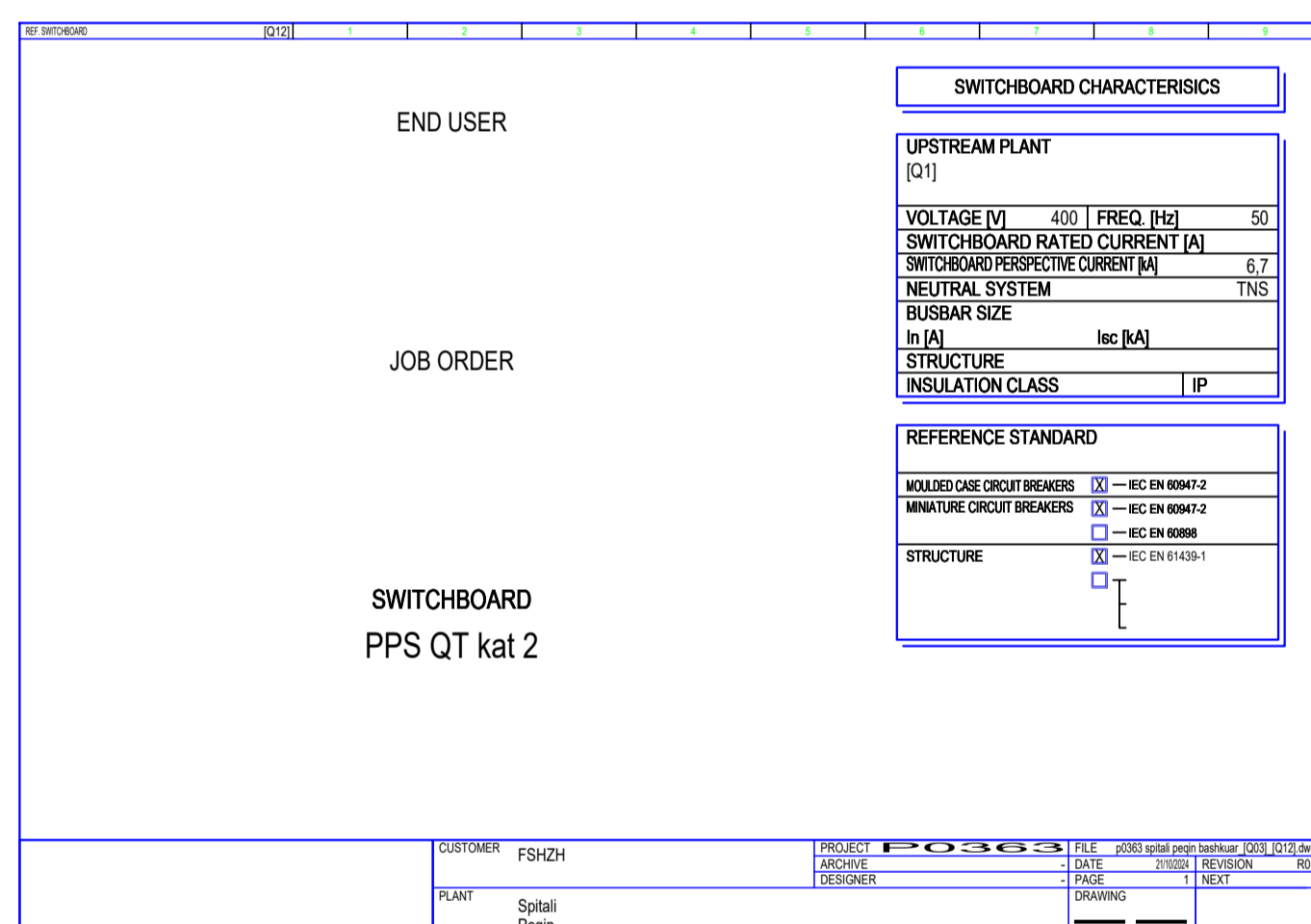
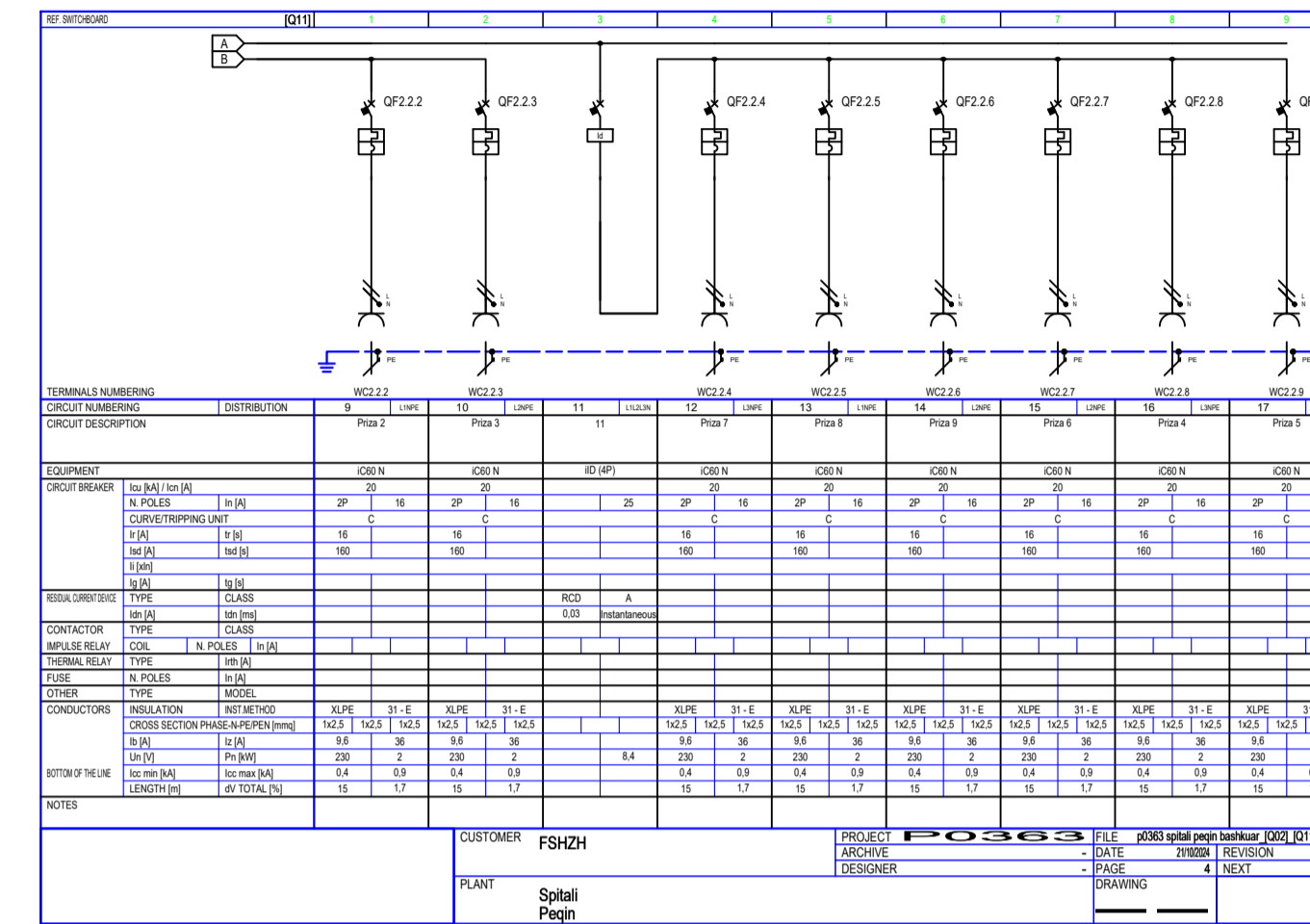
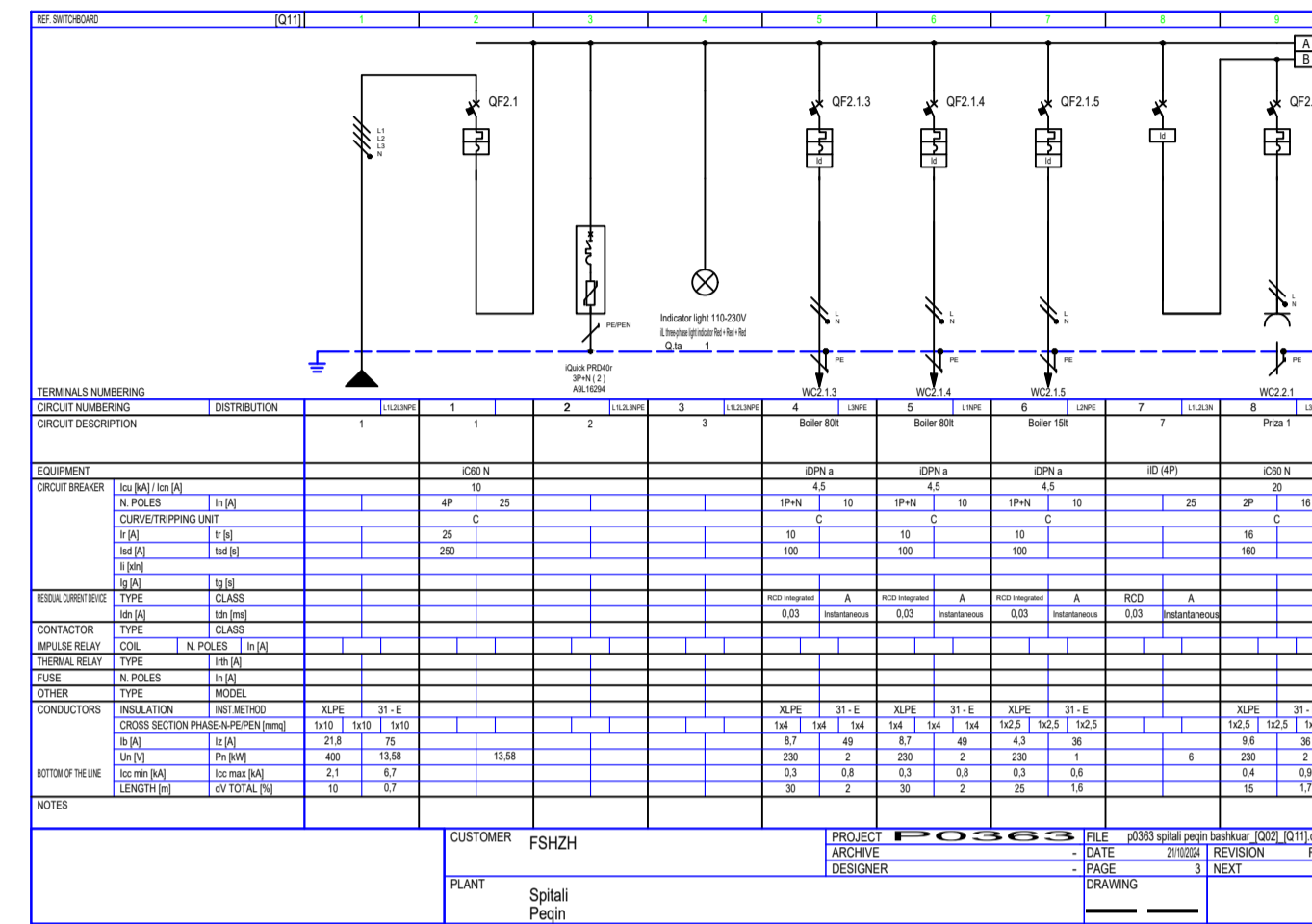
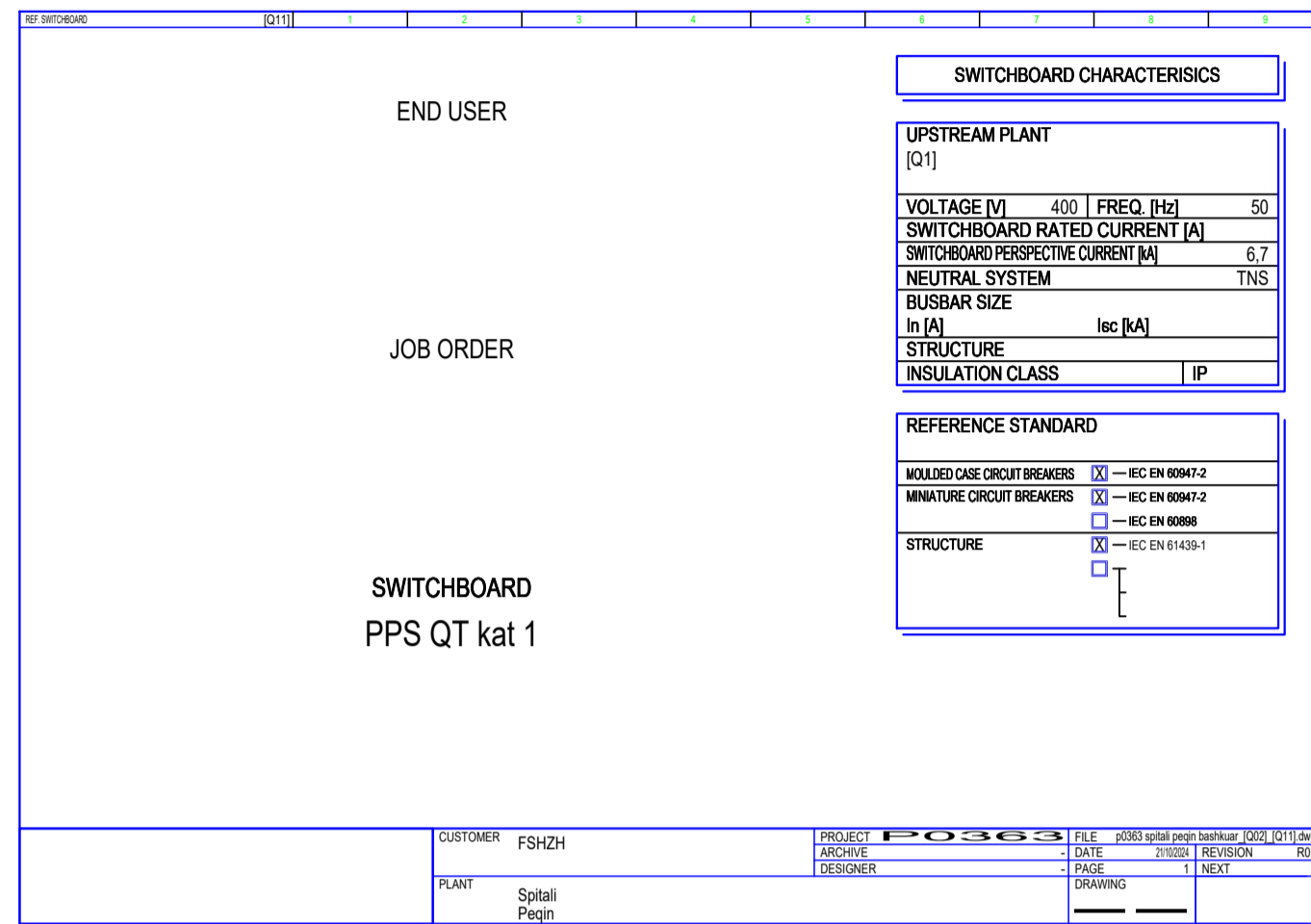

00	Tetor 2024	Projekt Leje	
RISH. NR.	DATA	QELIMI I DOREZIMIT	SHENIM / PERSHKRIM



KONSULENTI INXHINIERIK

Nr. Licenses: N.5221/16

**ICE**

ILLYRIAN CONSULTING ENGINEERS  
Adresa: Rr. "Sami Frashëri", Pallat "Hera", Kat 11, Tiranë, SHIPKRI  
Tel/Fax: +355 4 200 970, Email: info@ice.al, www.ice.al

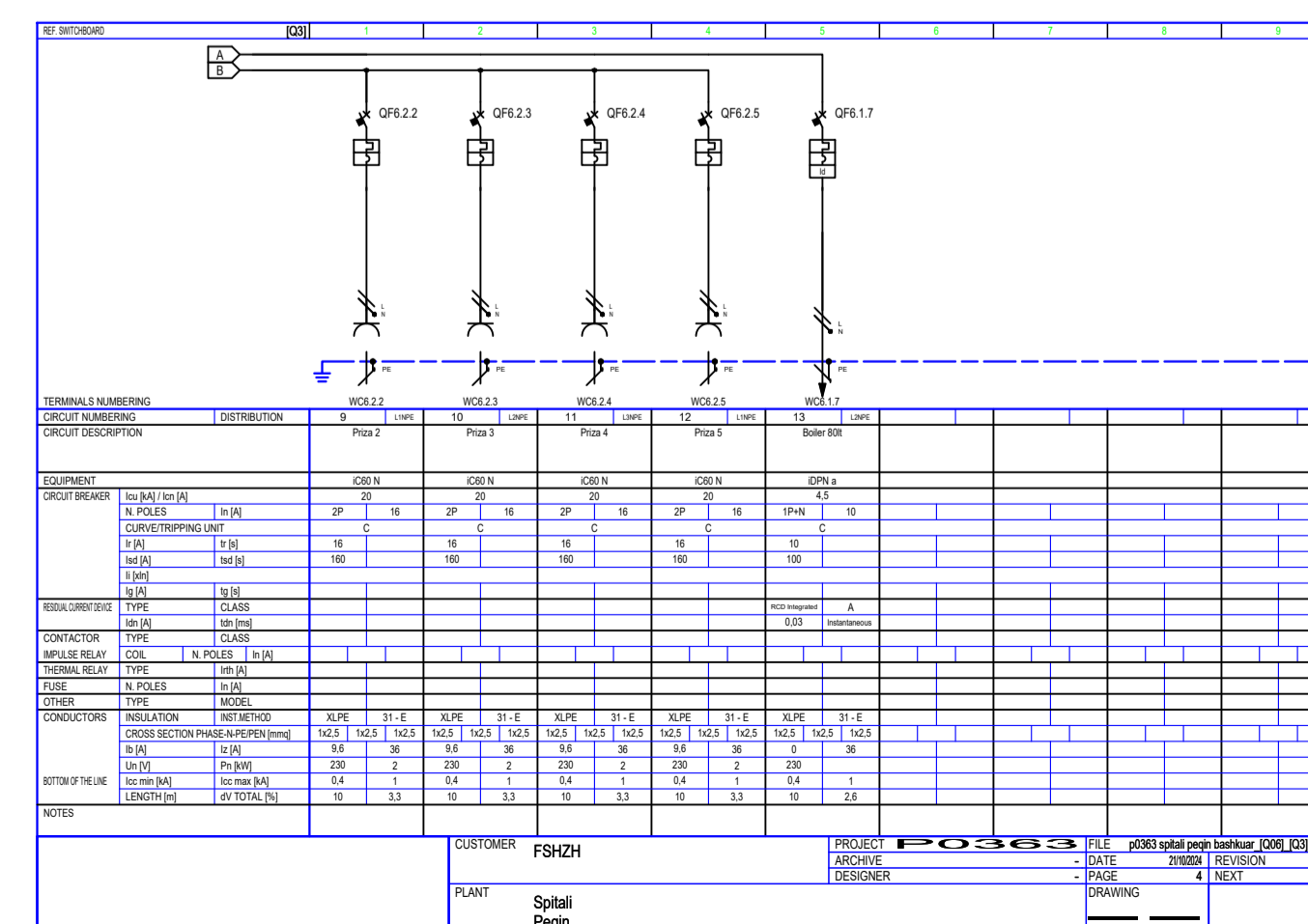
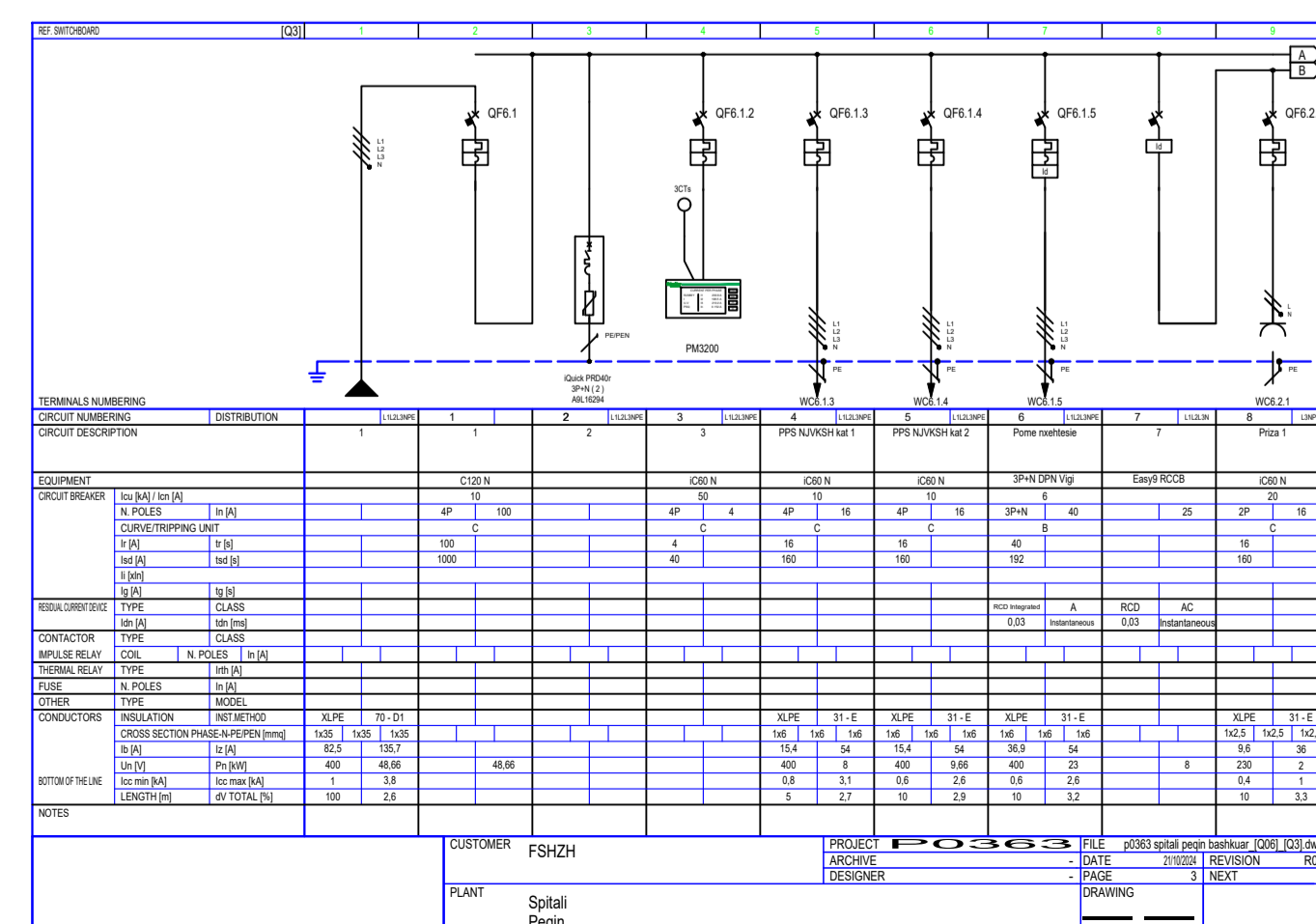
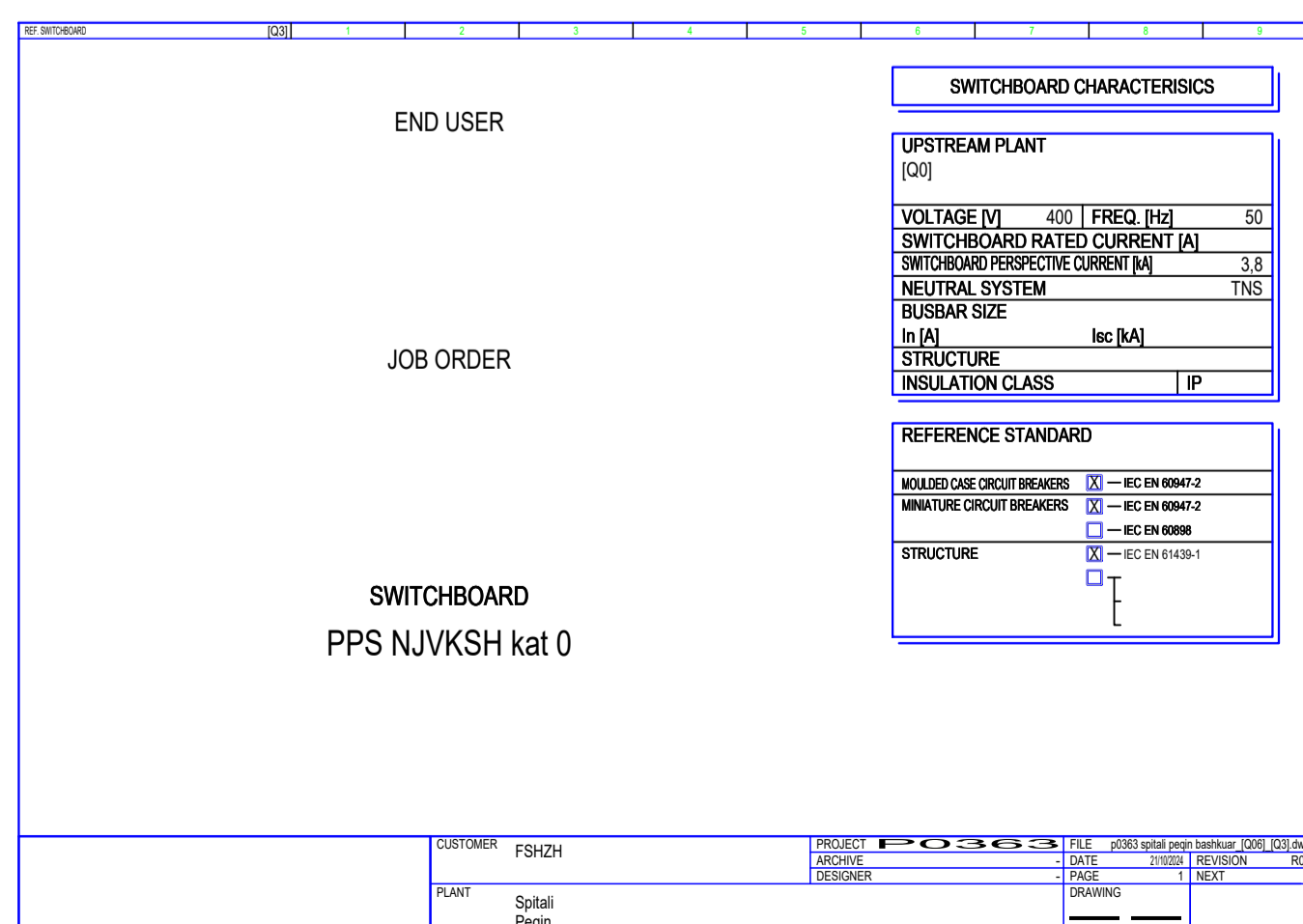
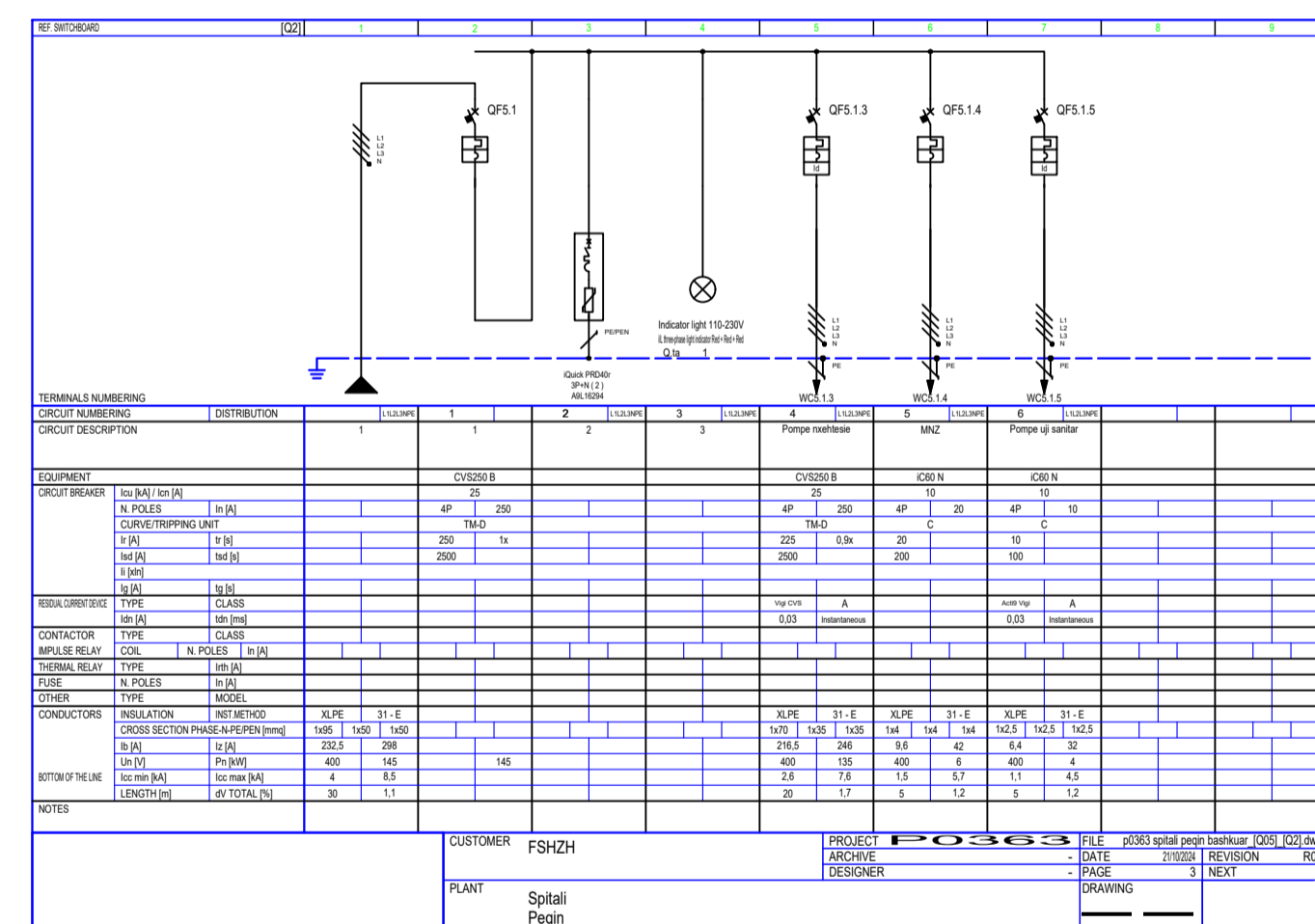
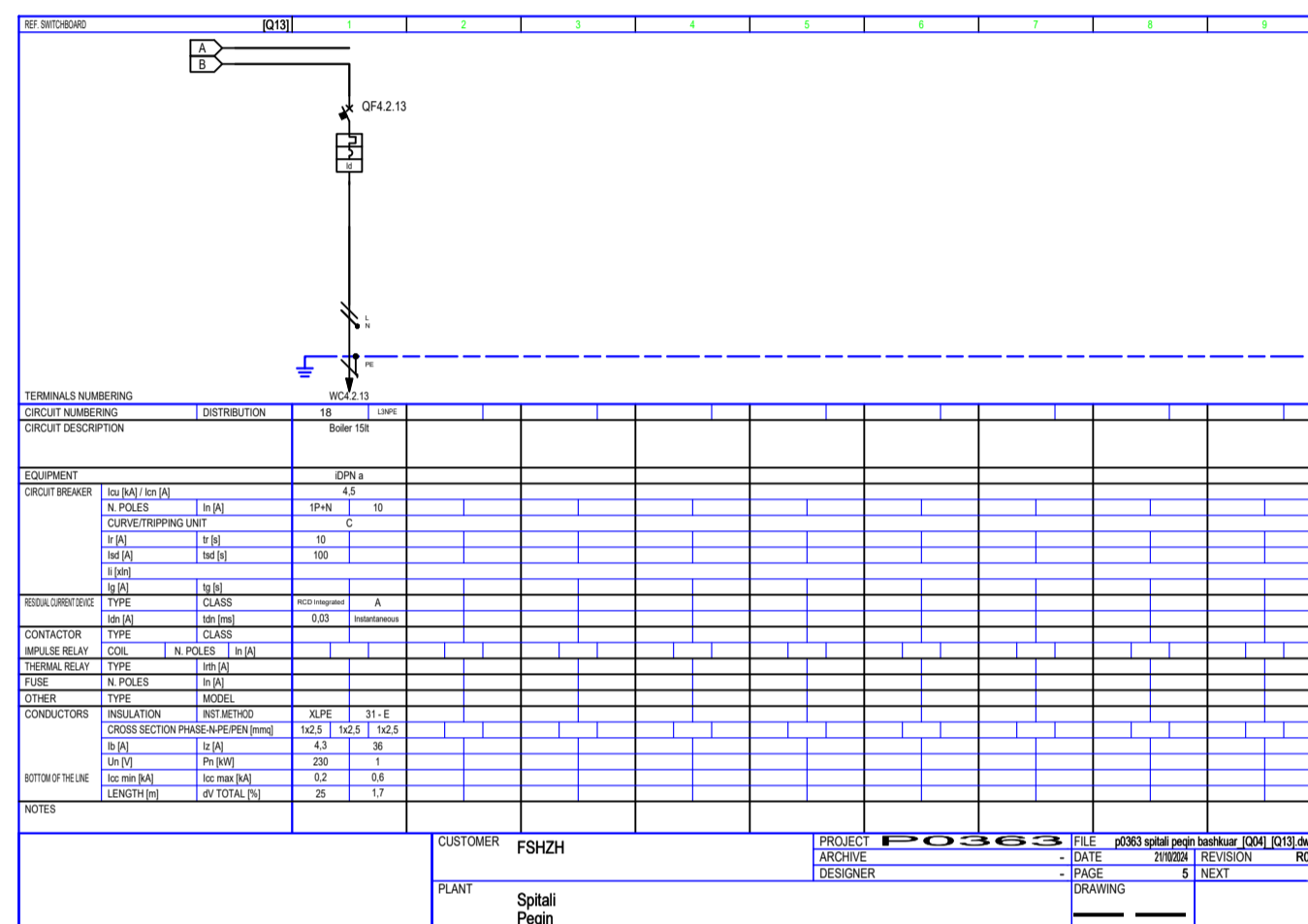
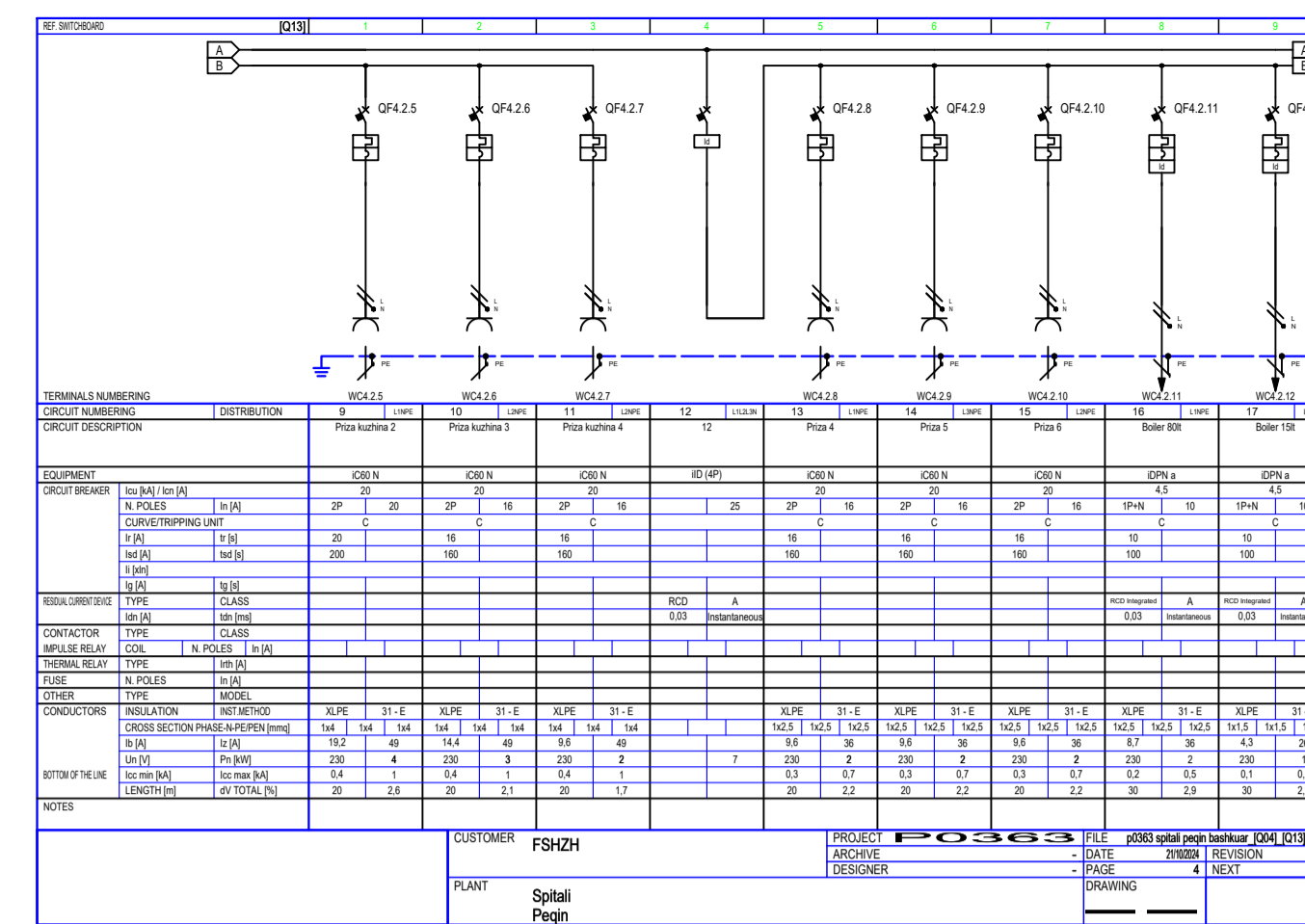
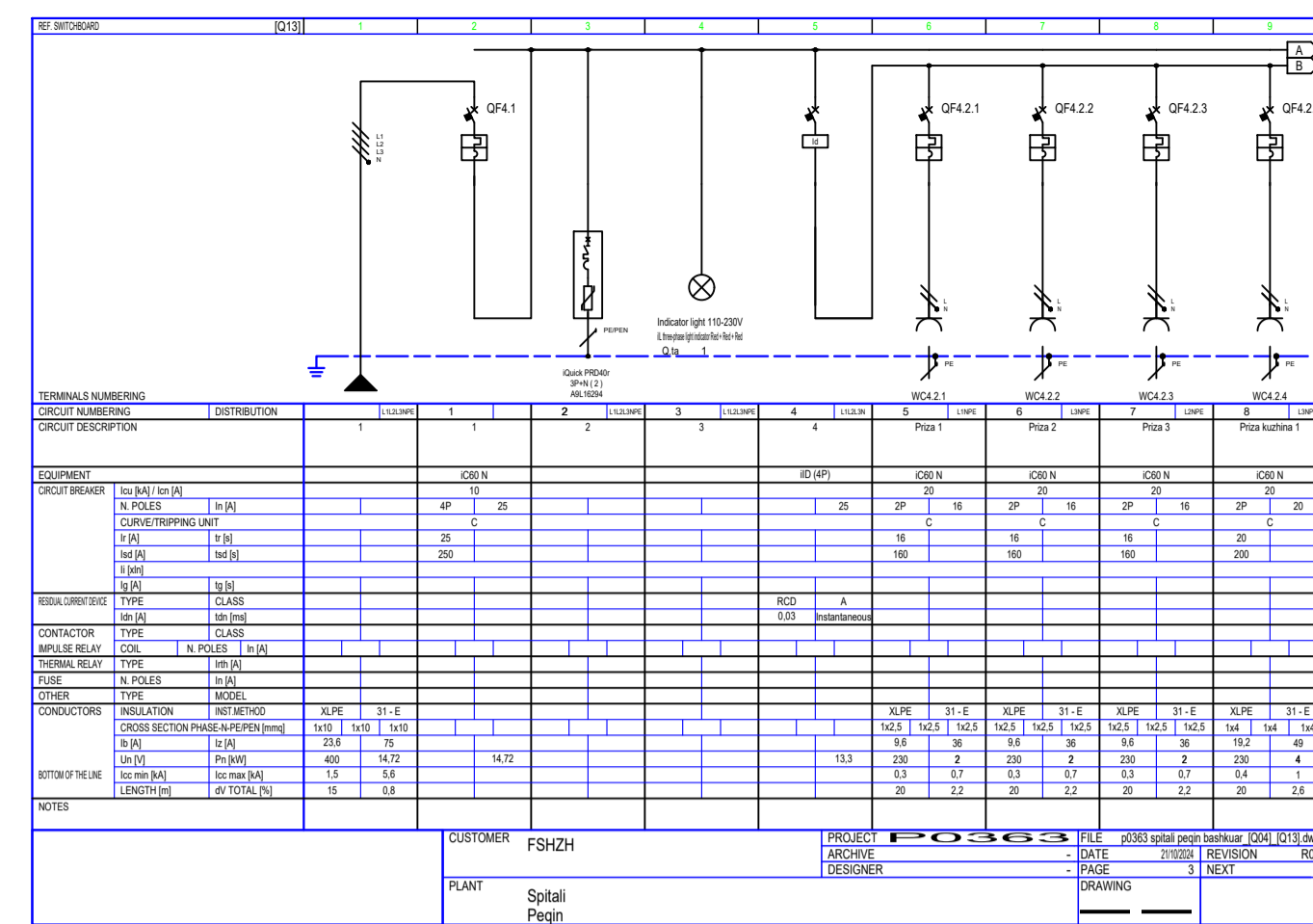
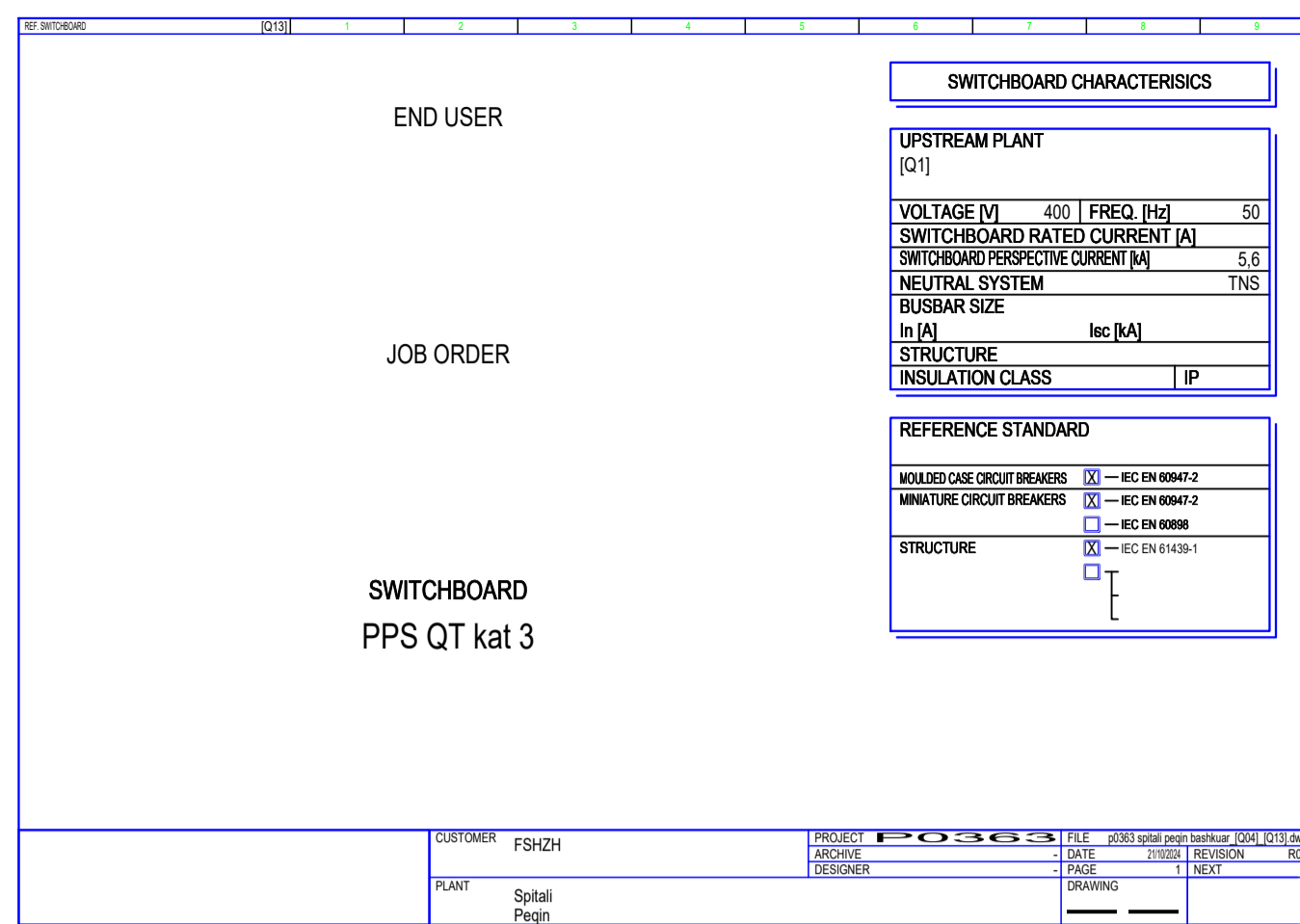

Përgatiti:	Arkitekt	Emri	Nr. Licenses	Firma
	Ing. Strukturist	Edmond MANAHASA	A.0903/2	
	Ing. Strukturist	Anila SPAHIU	K.1068/4	
	Ing. Hidroteknik	Aida VOKA	K.1340/2	
	Ing. Hidroteknik	Artjola ZOTAJ	K.3443	
	Ing. Hidroteknik	Silvia GJONAJ		
	Ing. Hidroteknik	Anzhela BICI	K.3452	
	Ing. Elektrik	Enis HAVERIKU	E.1450	
	Ing. Elektrik	Ilber PUCI		
	Ing. Mekanik	Marsel PYLLA	M.1288/1	
Kontrolli:	Ing. Mekanik	Besnik KARAJ	M.0256/2	
	Koordinator Projekti	Abdurrahman SPAHIU	K.1571/5	
	Ing. Strukturist	Taulant KARRIQI	K.1547/6	
	Ing. Elektrik	Emira BERSHA	E.0550/4	
Mirato:	Drejtes Projekt	Olset HAXHIU	K.1619/5	

TITULLI I PROJEKTIT					
INVESTIME PILOT PËR TRANSFORMIMIN E INFRASTRUKTURËS SË SHËRBIMEVE DHE RRTJES SË STANDARDIT TË JETËS NË KOMUNITET					
Objekti: Ndërrhyrje për rikonstrukcionin e sptalit të Peqinit dhe ndryshim i pjesshëm i funksionit të tij					
EMRI I DOKUMENTIT					
SKEMAT ELEKTRIKE TË FURNIZIMIT ME ENERJJI ELEKTRIKE DHE MBOJTJES SË PAJISJIVE ELEKTRIKE / SINGLE LINE DIAGRAMS OF ELECTRICAL ENERGY SUPPLY AND PROTECTION OF ELECTRICAL EQUIPMENT					
FAZA E PROJEKTIT	Nr. i Dokumentit	Shkalla	Rishikimi	Përmasa e fletës	Fleta
PROJEKT LEJE	E-02	-	00	A1 (841x594mm)	3/10

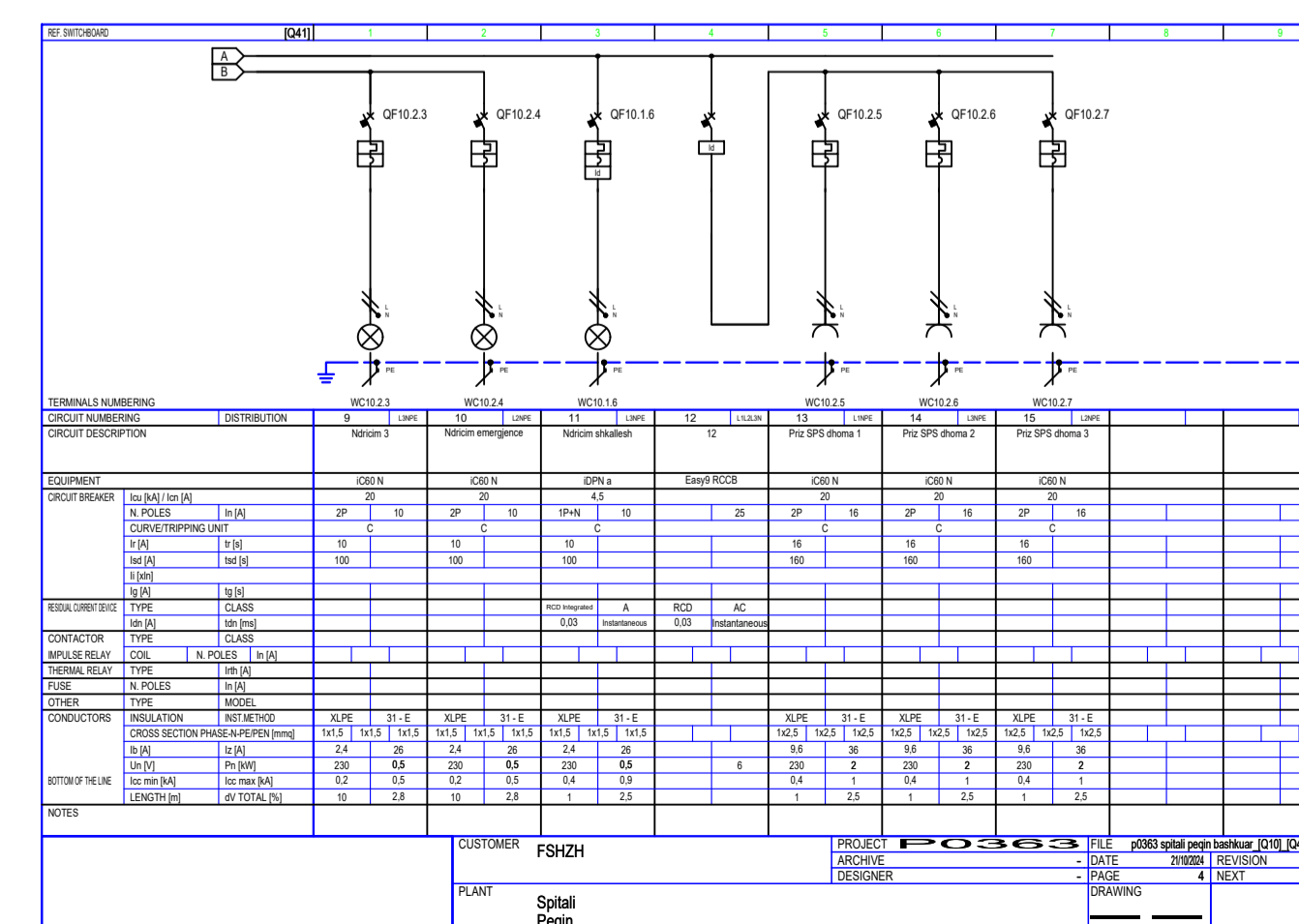
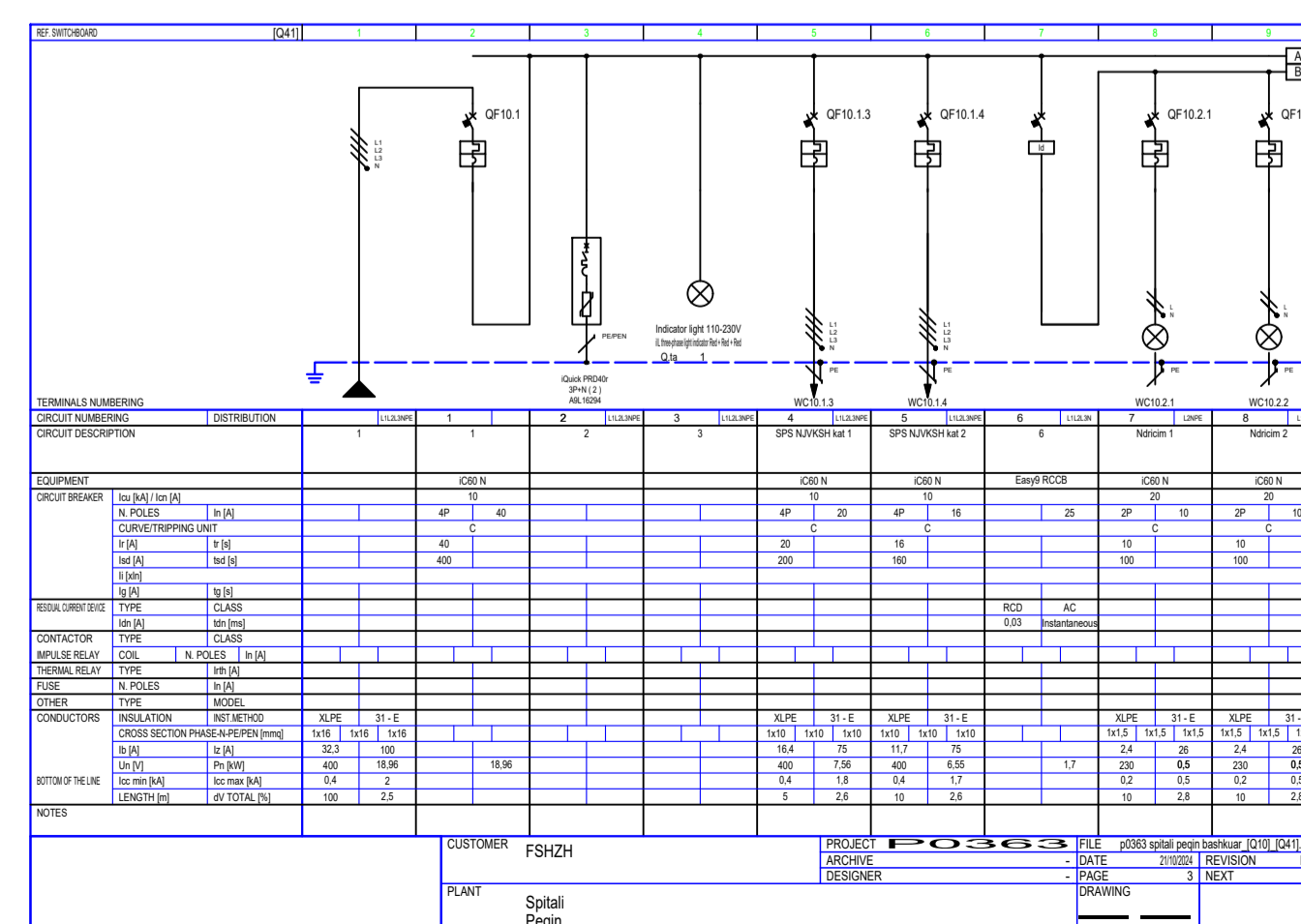
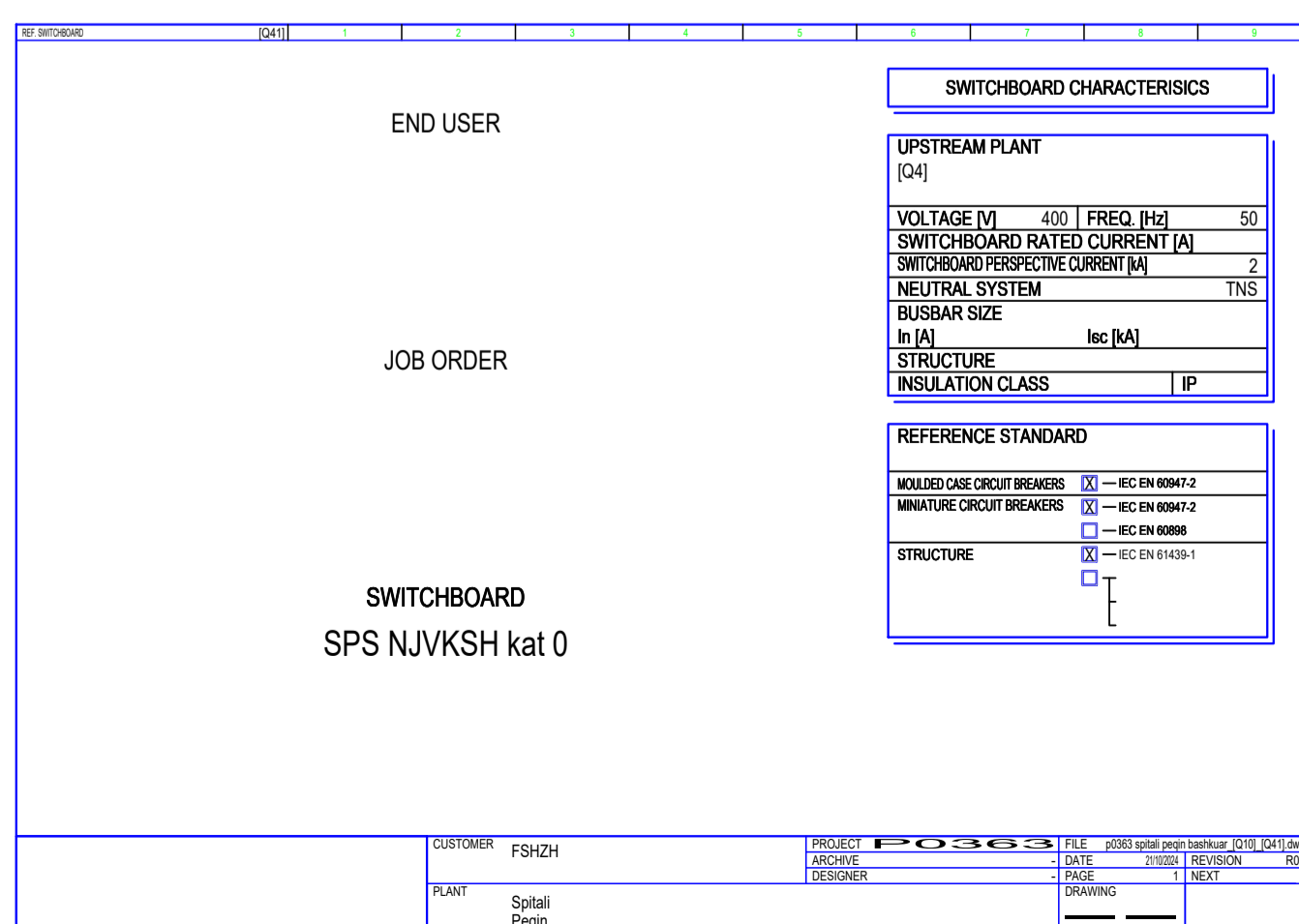
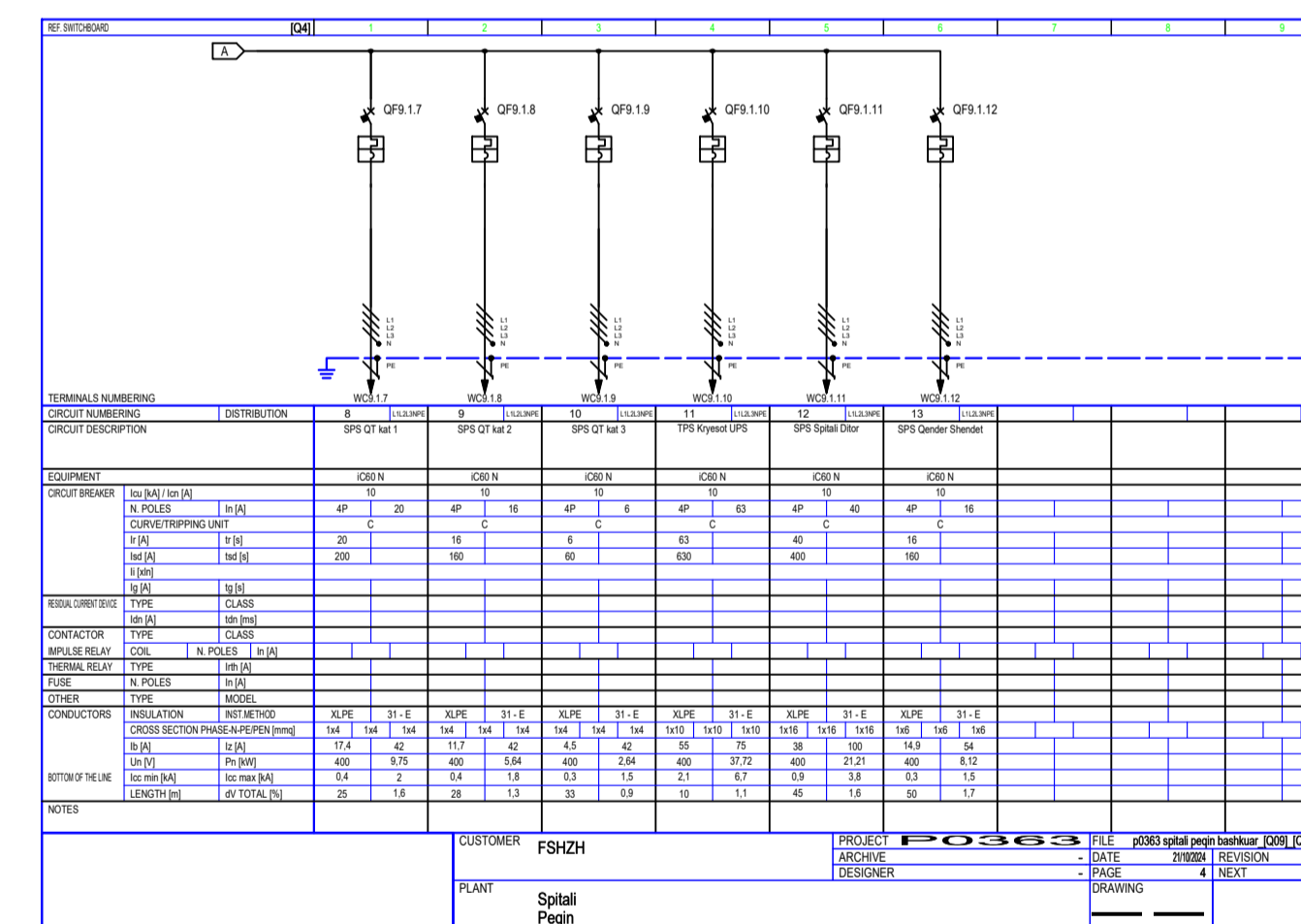
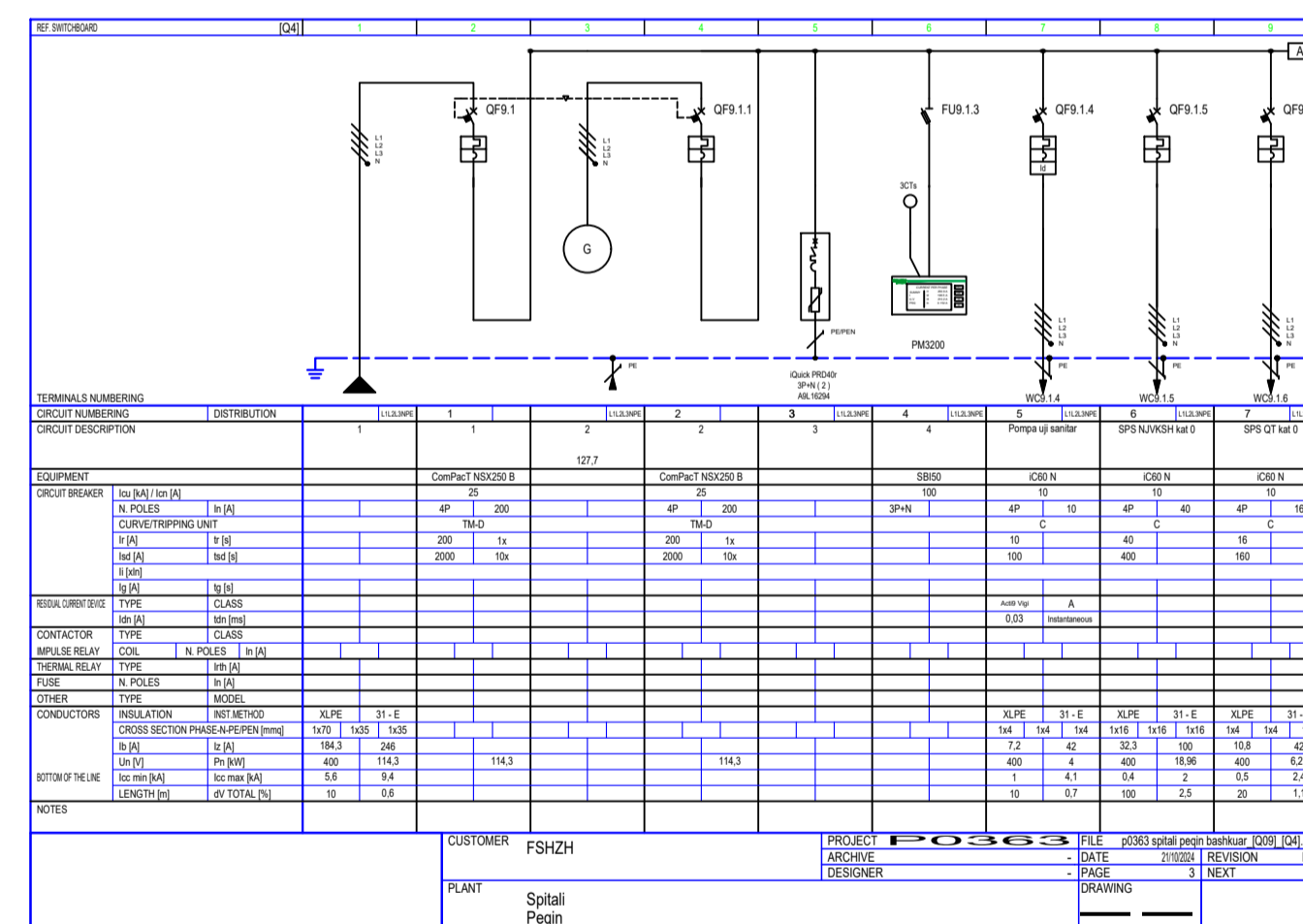
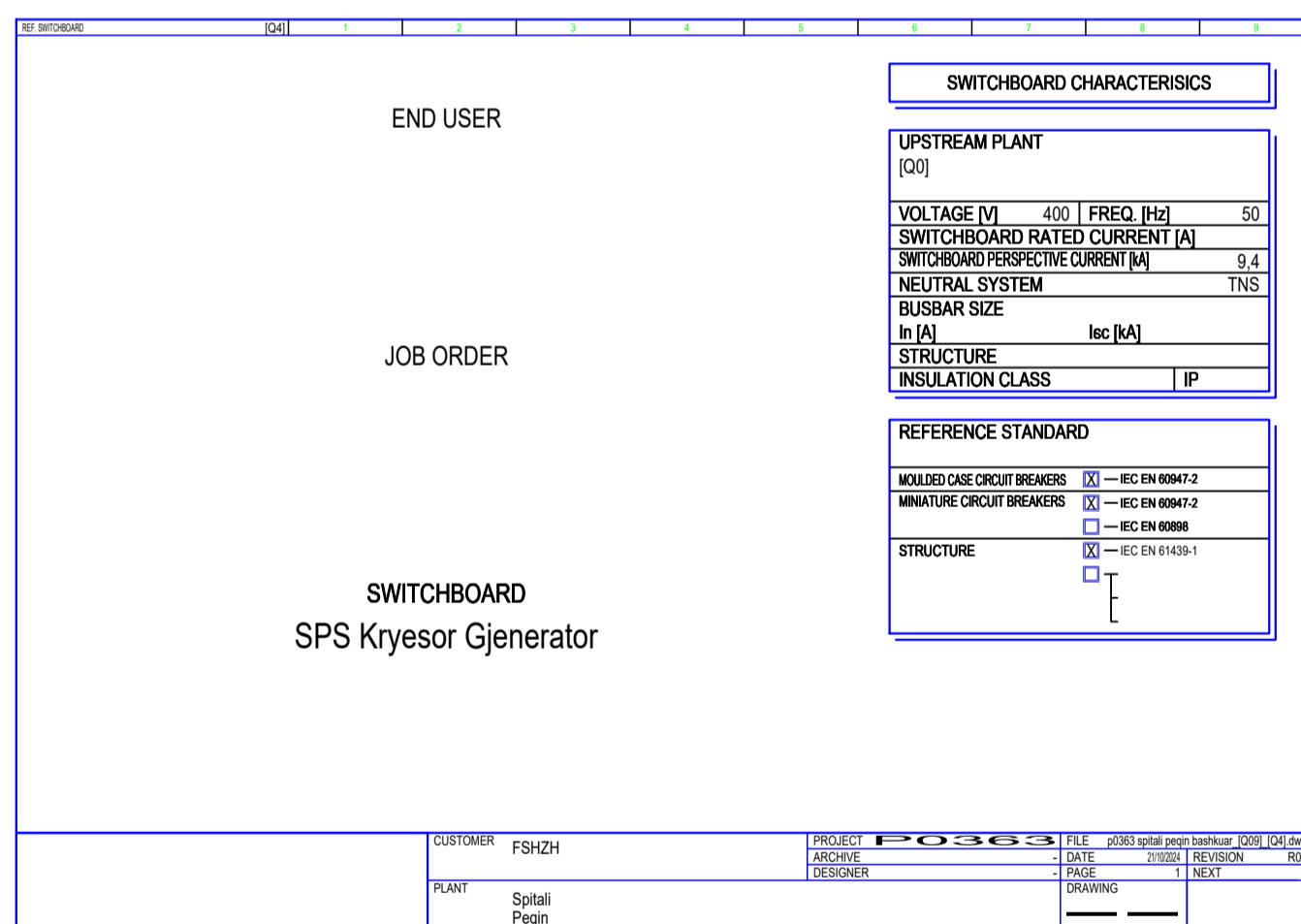
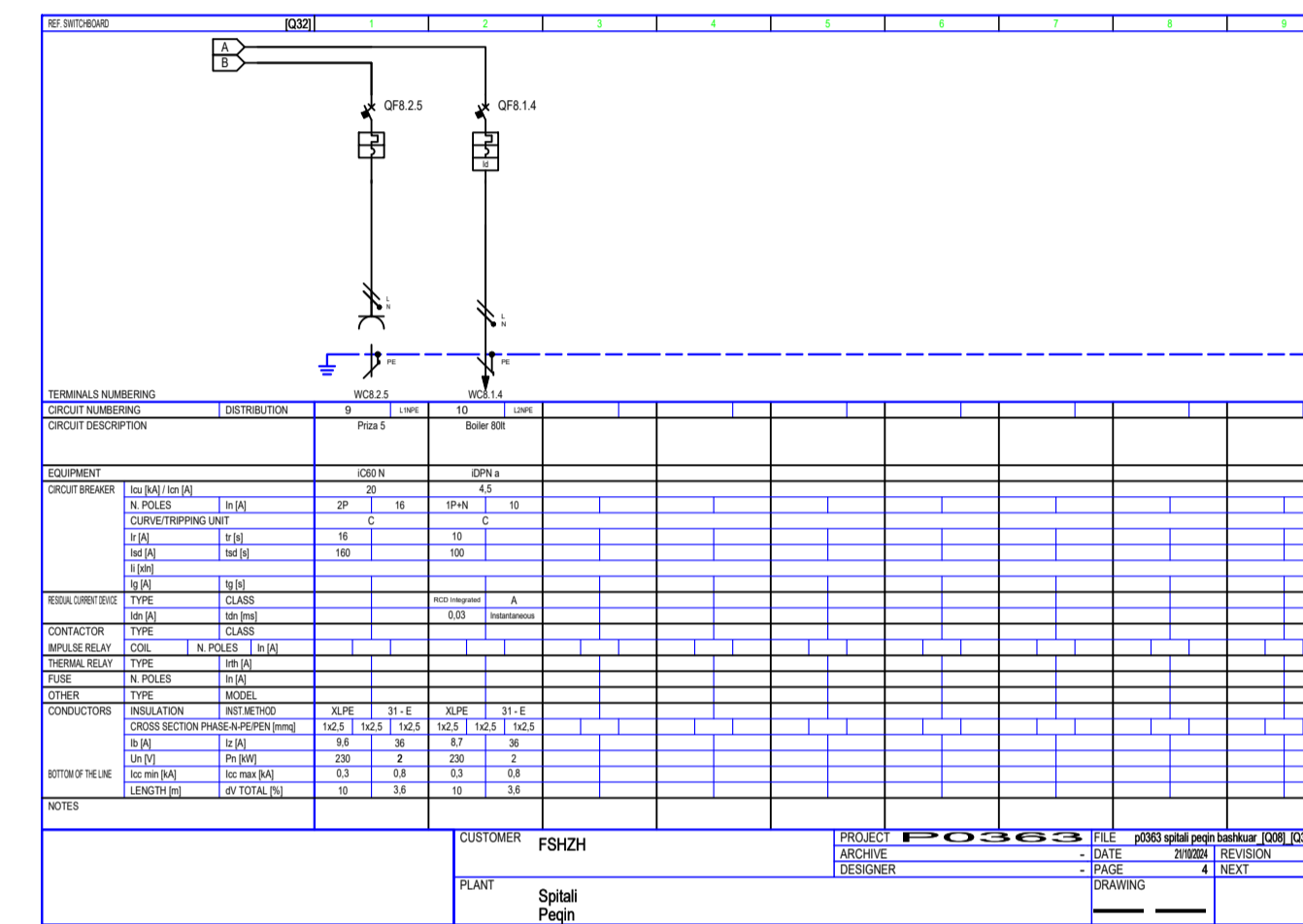
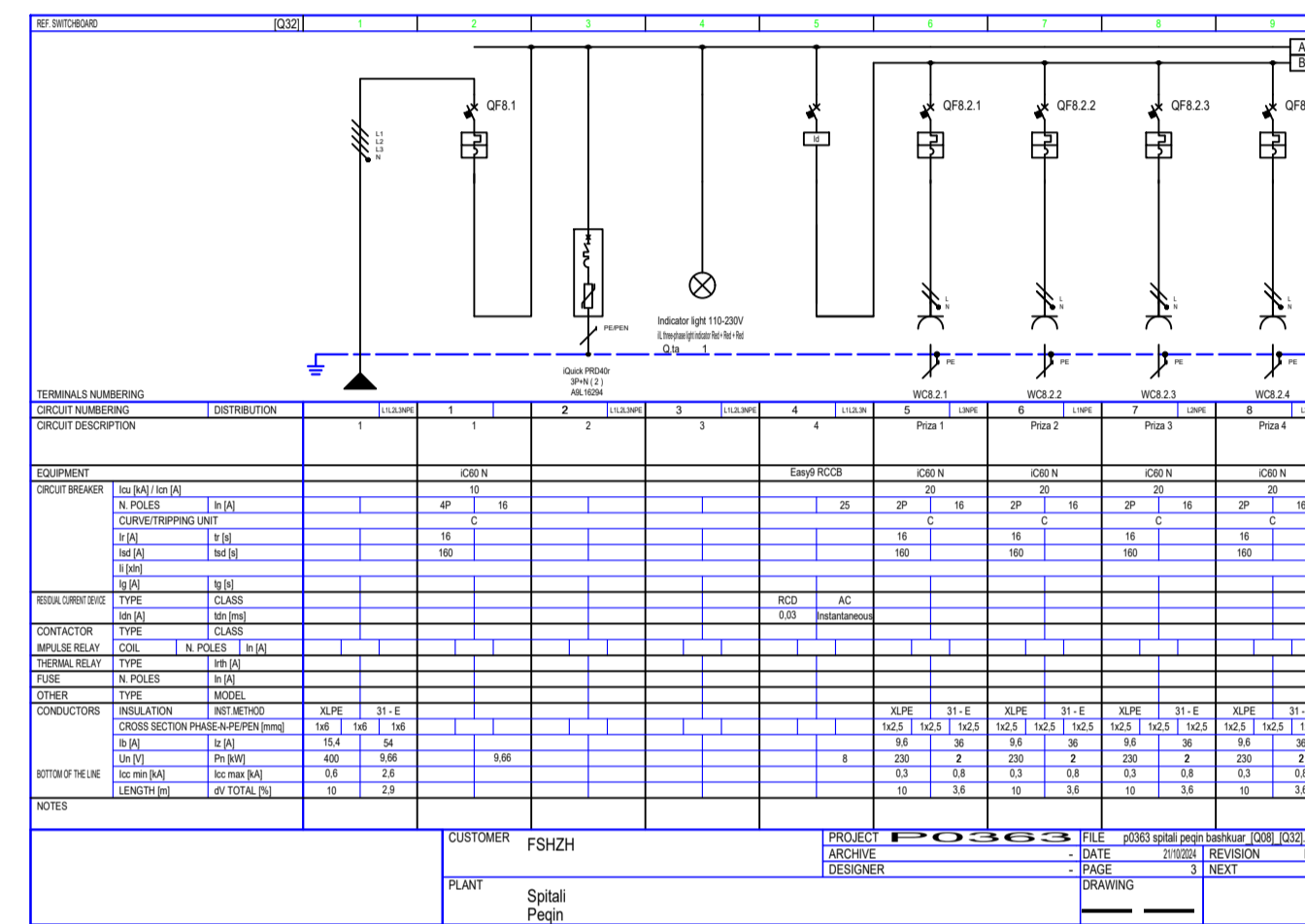
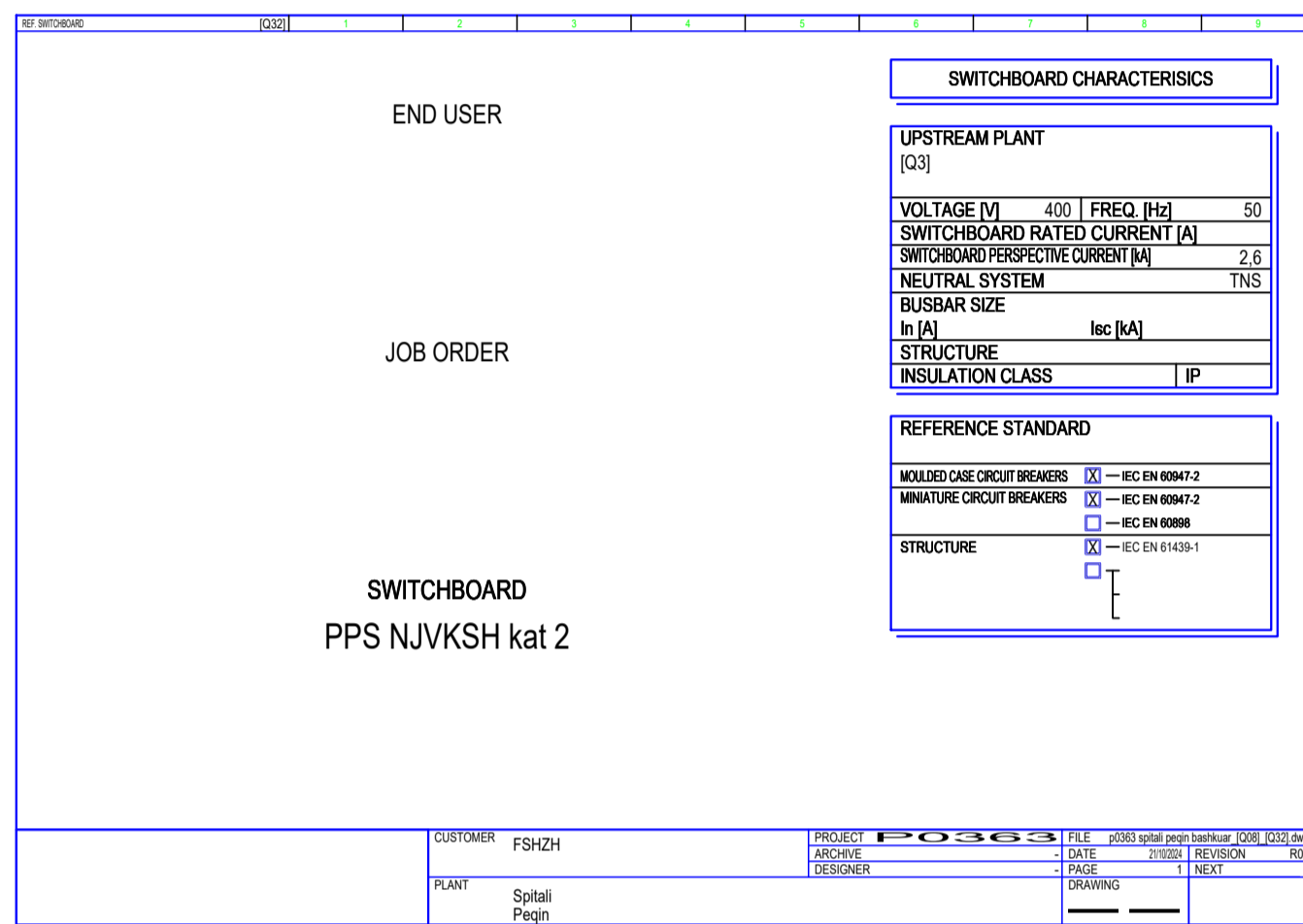
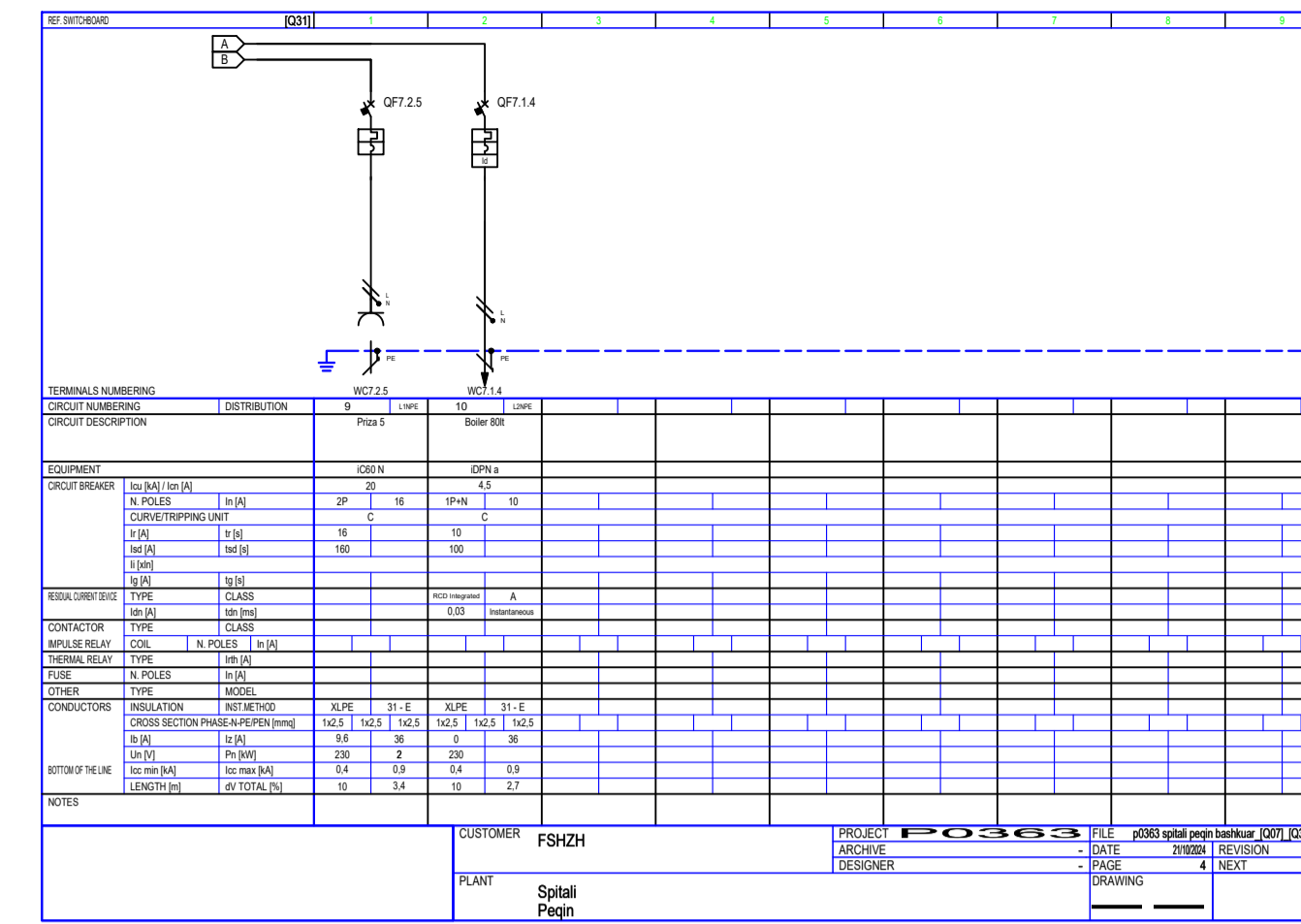
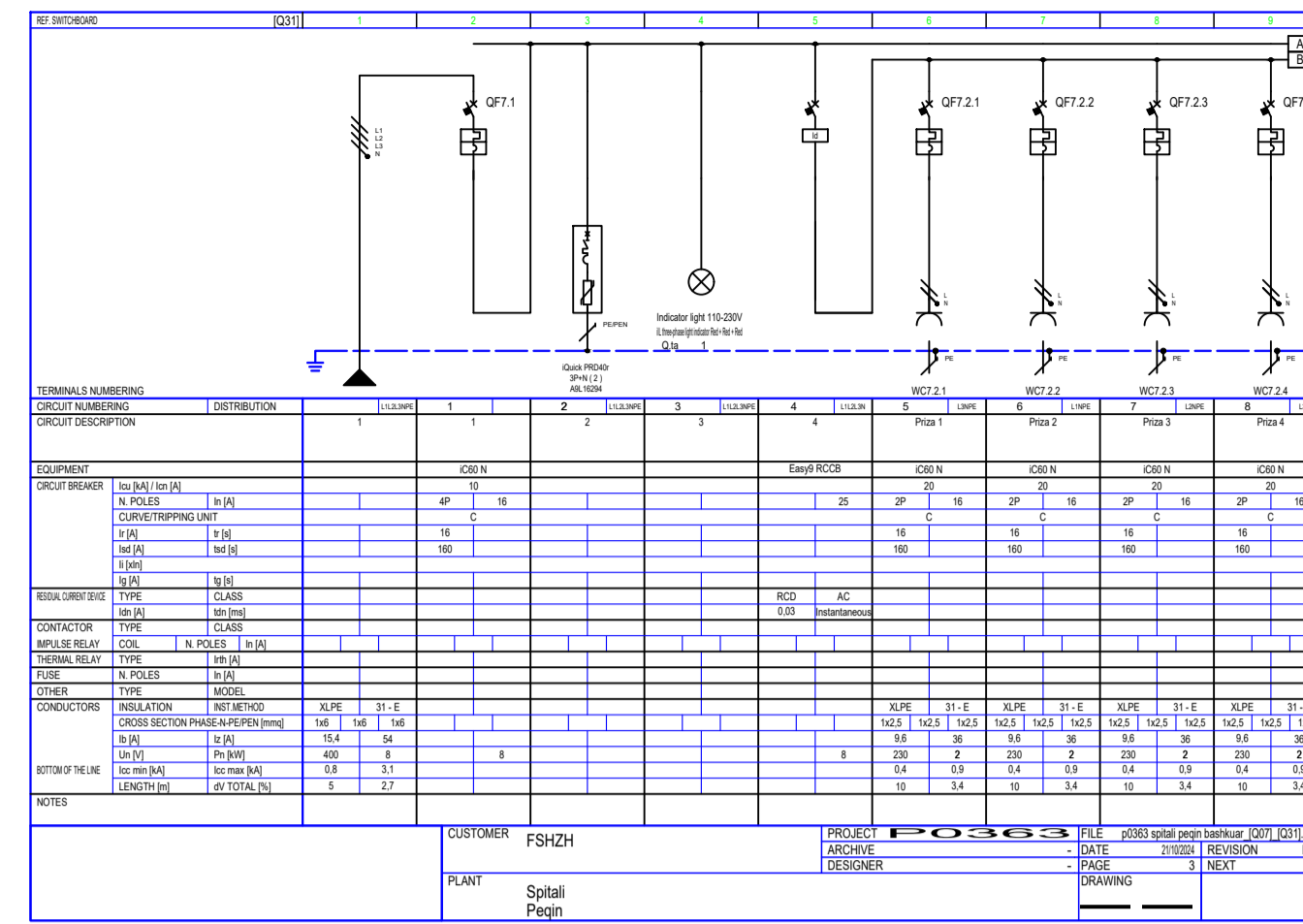
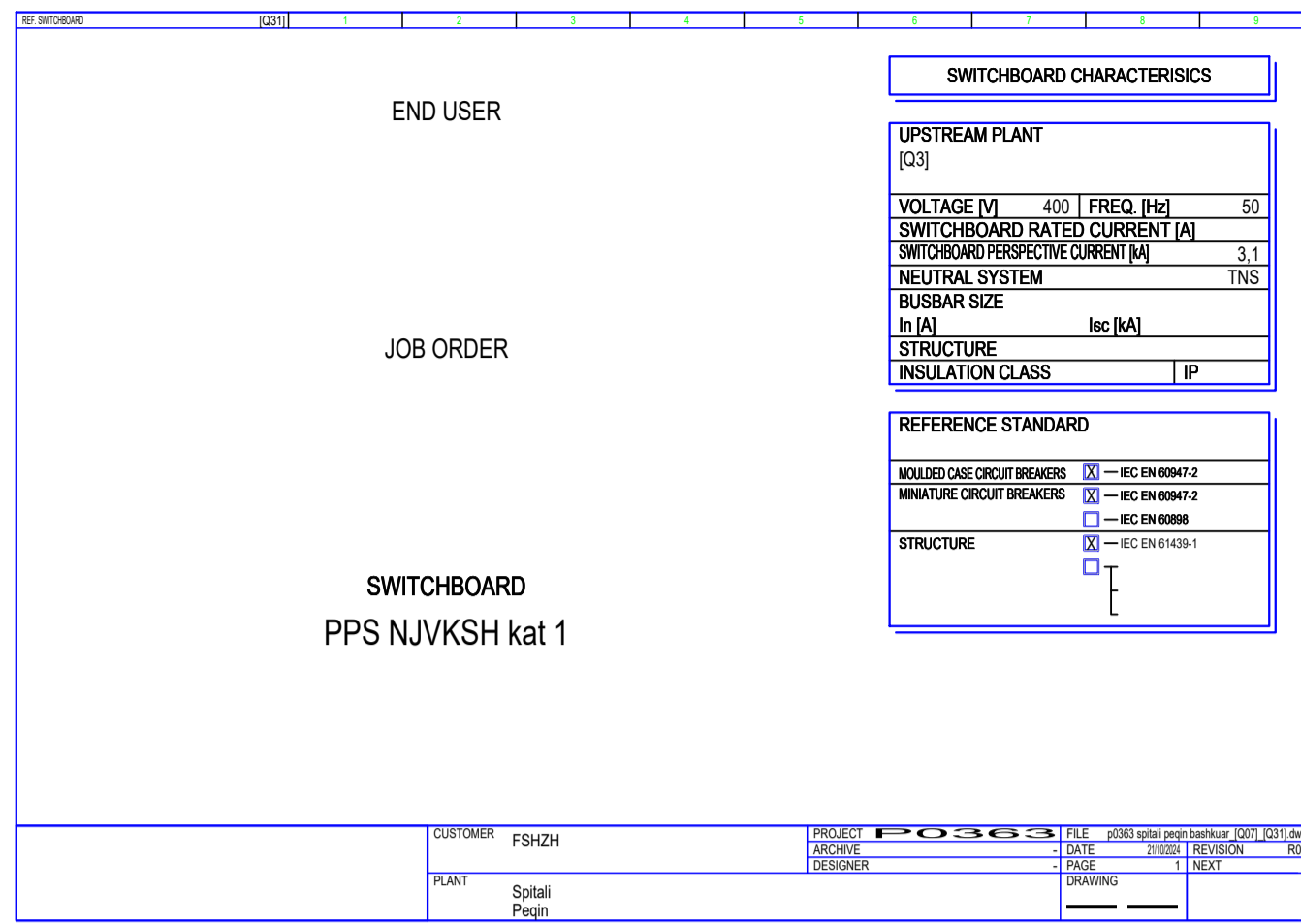

00	Tetor 2024	Projekt Leje	
RISH. NR.	DATA	QELIMI I DOREZIMIT	SHENIM / PERSHKRIM
INVESTITORI			
KONSULENTI INXHINIERIK			
Nr. Licencës: N.5221/16			
Përgatiti:	Arkitekt	Emri	Nr. Licensës
	Ing. Strukturist	Edmond MANAHASA	A.0903/2
	Ing. Strukturist	Anila SPAHIU	K.1068/4
	Ing. Hidroteknik	Alda VOKA	K.1340/2
	Ing. Hidroteknik	Artjola ZOTAJ	K.3443
	Ing. Hidroteknik	Silvia GJONAJ	
	Ing. Hidroteknik	Anzhela BICI	K.3452
	Ing. Elektrik	Enis HAVERIKU	E.1450
	Ing. Elektrik	Ilber PUCI	
	Ing. Mekanik	Marsel PYLLA	M.1288/1
Kontrolloi:	Ing. Mekanik	Besnik KARAJ	M.0256/2
	Koordinator Projekt	Abdurrahman SPAHIU	K.1571/5
	Ing. Strukturist	Taulant KARRIQI	K.1547/6
	Ing. Elektrik	Emira BERSHA	E.0550/4
Miratoi:	Drejtes Projekt	Oset HAXHIU	K.1619/5
TITULLI I PROJEKTTIT			
<b>INVESTIME PILOT PËR TRANSFORMIMIN E INFRASTRUKTURËS SË SHËRBIMEVE DHE RRTJES SË STANDARDIT TË JETËS NË KOMUNITET</b>			
<b>Objekti: Ndërrhyrje për rikonstrukcionin e spitalit të Peqinit dhe ndryshim i pjesshëm i funksionit të tij</b>			
EMRI I DOKUMENTIT			
<b>SKEMAT ELEKTRIKE TË FURNIZIMIT ME ENERGIJË ELEKTRIKE DHE MBOJTJES SË PAJISJVE ELEKTRIKE / SINGLE LINE DIAGRAMS OF ELECTRICAL ENERGY SUPPLY AND PROTECTION OF ELECTRICAL EQUIPMENT</b>			
FAZA E PROJEKTTIT	Nr. i Dokumentit	Shkalla	Rishikimi
PROJEKT LEJE	E-02	-	00
			Përmasa e fletës
			A1 (841x594mm)
			Fleta
			4/10



00	Tetor 2024	Projekt Lejë		
RISH. NR.	DATA	QELIMI I DOREZIMIT	SHENIM / PERSHKRIM	
INVESTITORI				
 <b>FONDI SHOPTAR I ZHVILLIMIT</b>				
KONSULENTI INXHINIERIK				
Nr. Licencës: N.5221/16				
 <b>icE</b> ILLYRIAN CONSULTING ENGINEERS Adresa: Rr. "Sam Frashëri", Pallat "Hoxha", Kat 11, Tiranë, SHQIPËRI Tel/Fax: +355 4 200 9712   Email: info@ice.al   www.ice.al				
Përgatiti:	Arktekt	Emri	Nr. Licencës	Firma
	Ing. Strukturist	Edmond MANAHASA	A.0903/2	
	Ing. Strukturist	Anila SPAHIU	K.1068/4	
	Ing. Hidroteknik	Alda VOKA	K.1340/2	
	Ing. Hidroteknik	Artjola ZOTAJ	K.3443	
	Ing. Hidroteknik	Silvia GJONAJ		
	Ing. Hidroteknik	Anzheta BICI	K.3452	
	Ing. Elektrik	Enis HAVERIKU	E.1450	
	Ing. Elektrik	Ilber PUCI		
	Ing. Mekanik	Marsel PYLLA	M.1288/1	
Kontrolloi:	Ing. Mekanik	Besnik KARAJ	M.0256/2	
	Koordinator Projekti	Abdurrahman SPAHIU	K.1571/5	
	Ing. Strukturist	Taulant KARRIQI	K.1547/6	
	Ing. Elektrik	Emira BERISHA	E.0550/4	
Miratoi:	Drejtes Projekt	Oset HAXHIU	K.1619/5	
TITULLI I PROJEKTTIT				
<b>INVESTIME PILOT PËR TRANSFORMIMIN E INFRASTRUKTURËS SË SHËRBIMEVE DHE RRTJES SË STANDARDIT TË JETËS NË KOMUNITET</b>				
<b>Objekti: Ndërrhyrje për rikonstrukcionin e spitalit të Pëqinit dhe ndryshim i pjesshëm i funksionit të tij</b>				
EMRI I DOKUMENTIT				
<b>SKEMAT ELEKTRIKE TË FURNIZIMIT ME ENERGIJË ELEKTRIKE DHE MBOJTJES SË PAJISJVE ELEKTRIKE / SINGLE LINE DIAGRAMS OF ELECTRICAL ENERGY SUPPLY AND PROTECTION OF ELECTRICAL EQUIPMENT</b>				
FAZA E PROJEKTTIT	Nr. i Dokumentit	Shkalla	Rishikimi	Përmasa e fletës
PROJEKT LEJË	E-02	-	00	A1 (841x594mm)
				5/10

END USER

JOB ORDER

SWITCHBOARD  
SPS NJVKSH kat 1

CUSTOMER FSHZH

PLANT Spitali Pëgn

PROJECT ARCHITECT FSHZH

DESIGNER

DATE 10.02.2024

REVISION

DRAWING 1

NEAT

SWITCHBOARD CHARACTERISTICS

UPSTREAM PLANT [D41]

VOLTAGE [V] 400 | FREQ [Hz] 50

SWITCHBOARD RATED CURRENT [A] 1.8

NEUTRAL SYSTEM TNS

BUSBAR SIZE In [A] Icc [kA]

STRUCTURE

INSULATION CLASS IP

REFERENCE STANDARD

MINI-CIRCUIT BREAKERS  — EC EN 60897-2

MINIATURE CIRCUIT BREAKERS  — EC EN 60898

STRUCTURE  — EC EN 61439-1

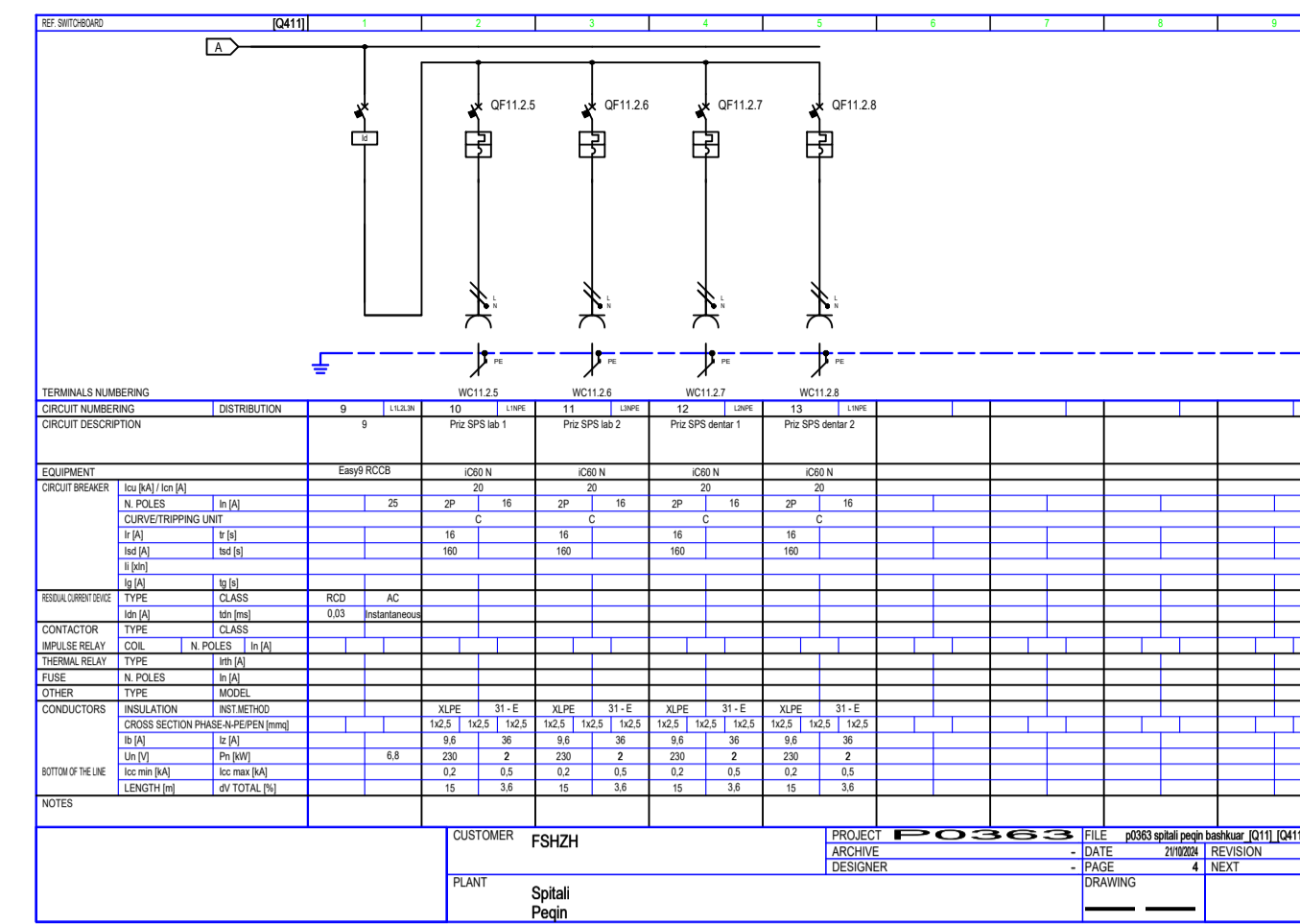
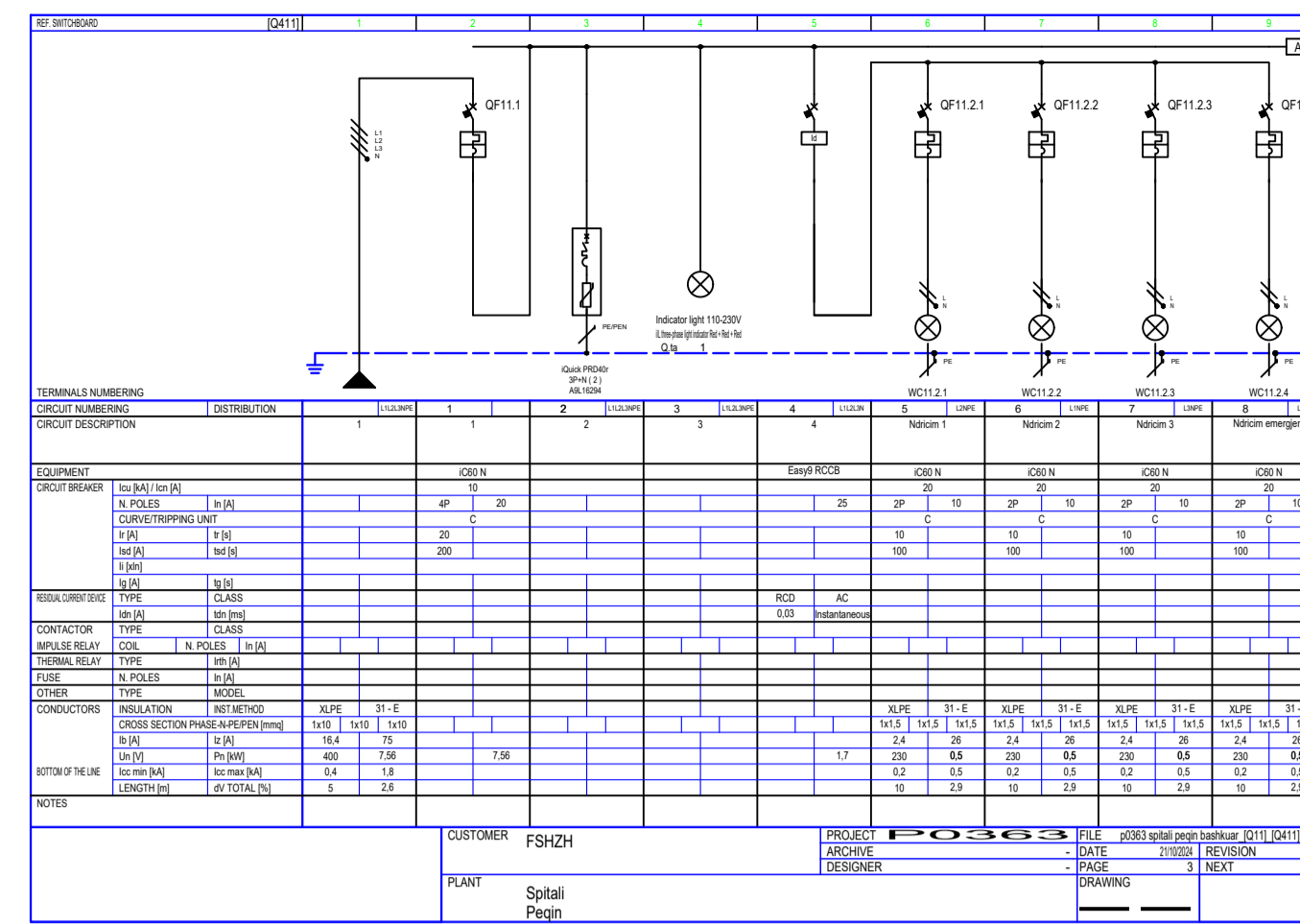

END USER

JOB ORDER

SWITCHBOARD  
SPS NJVKSH kat 2

CUSTOMER FSHZH

PLANT Spitali Pëgn

PROJECT ARCHITECT FSHZH

DESIGNER

DATE 10.02.2024

REVISION

DRAWING 1

NEAT

SWITCHBOARD CHARACTERISTICS

UPSTREAM PLANT [D41]

VOLTAGE [V] 400 | FREQ [Hz] 50

SWITCHBOARD RATED CURRENT [A] 1.7

NEUTRAL SYSTEM TNS

BUSBAR SIZE In [A] Icc [kA]

STRUCTURE

INSULATION CLASS IP

REFERENCE STANDARD

MINI-CIRCUIT BREAKERS  — EC EN 60897-2

MINIATURE CIRCUIT BREAKERS  — EC EN 60898

STRUCTURE  — EC EN 61439-1

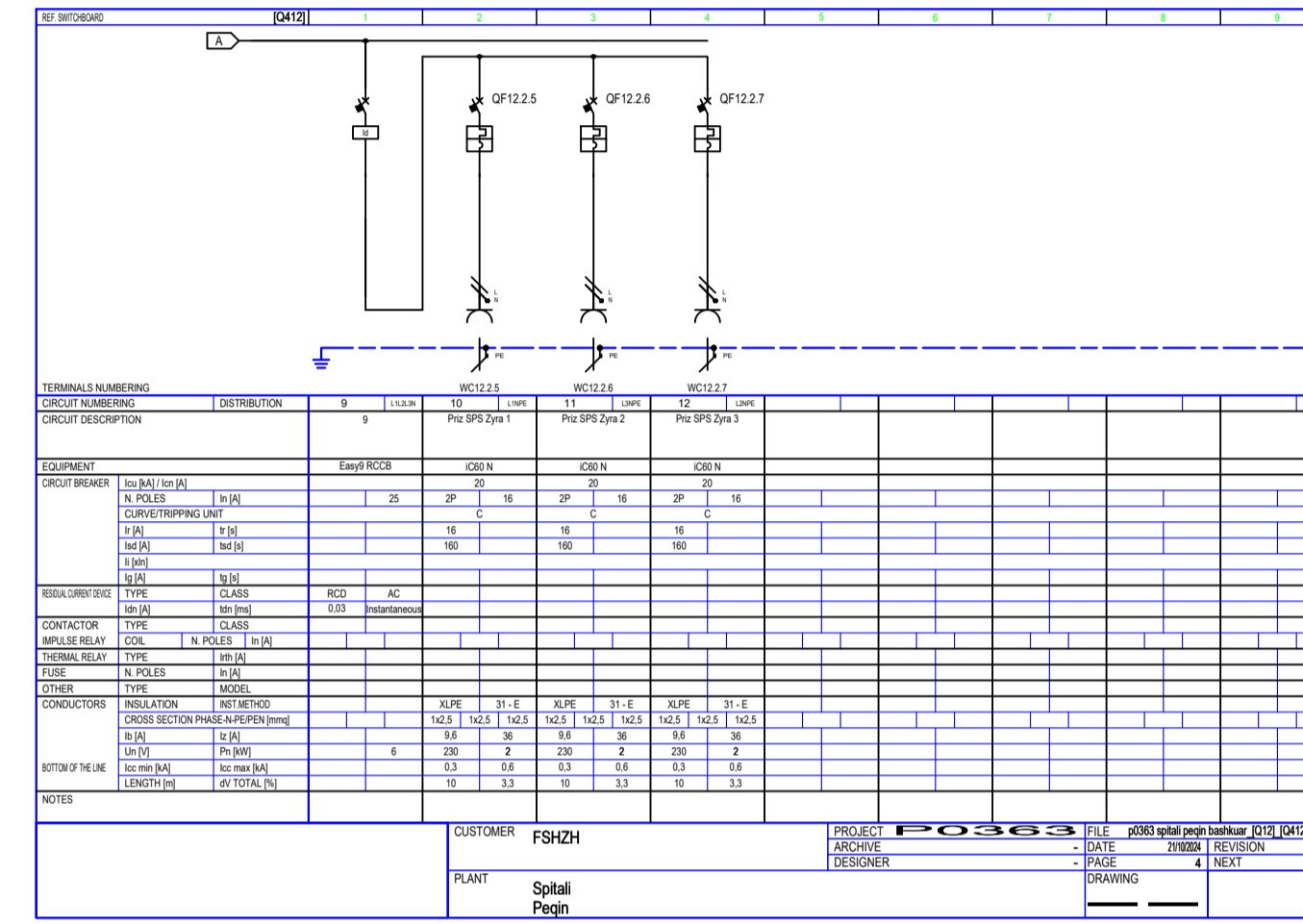
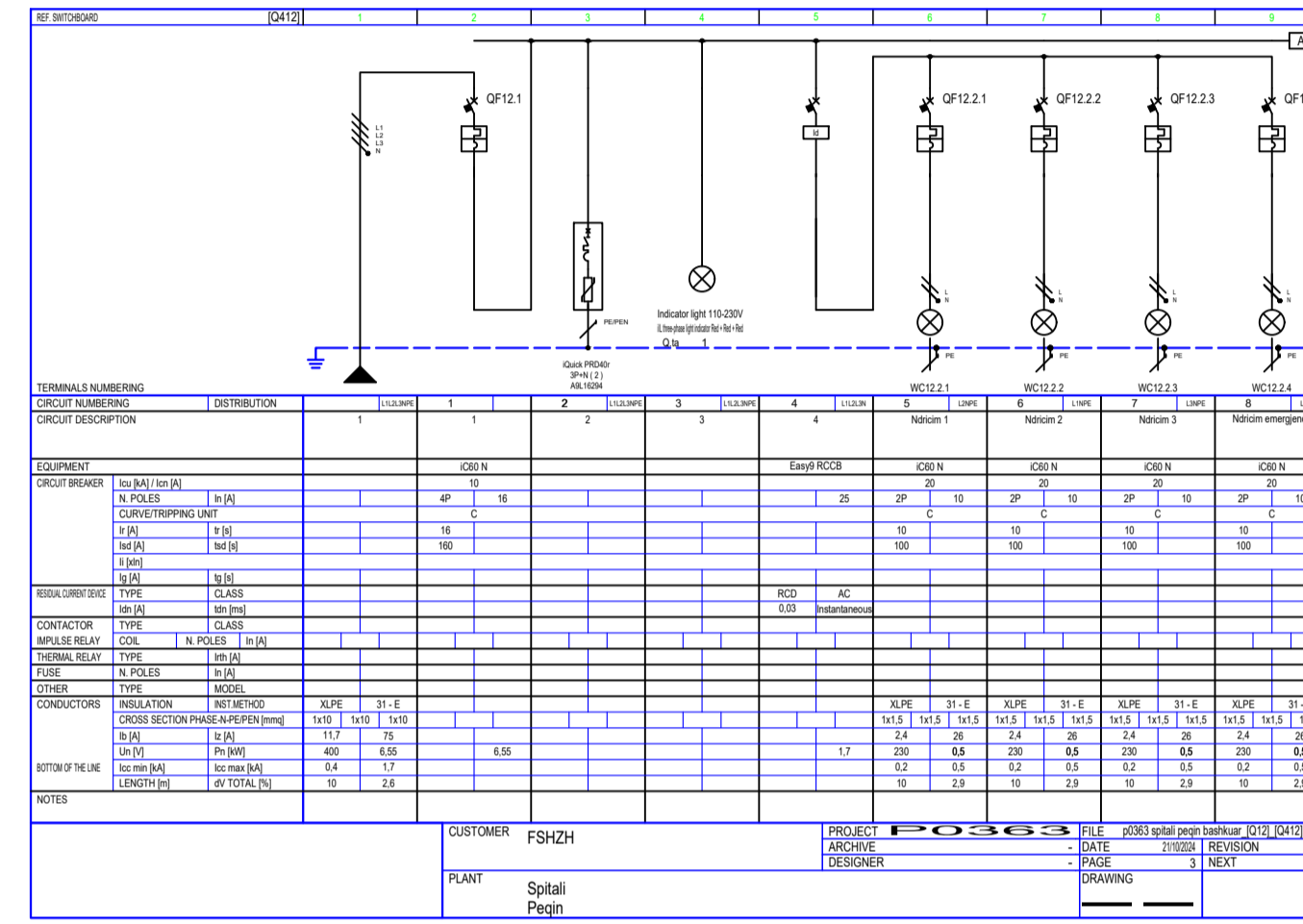

END USER

JOB ORDER

SWITCHBOARD  
SPS QT kat 0

CUSTOMER FSHZH

PLANT Spitali Pëgn

PROJECT ARCHITECT FSHZH

DESIGNER

DATE 10.02.2024

REVISION

DRAWING 1

NEAT

SWITCHBOARD CHARACTERISTICS

UPSTREAM PLANT [D41]

VOLTAGE [V] 400 | FREQ [Hz] 50

SWITCHBOARD RATED CURRENT [A] 2.4

NEUTRAL SYSTEM TNS

BUSBAR SIZE In [A] Icc [kA]

STRUCTURE

INSULATION CLASS IP

REFERENCE STANDARD

MINI-CIRCUIT BREAKERS  — EC EN 60897-2

MINIATURE CIRCUIT BREAKERS  — EC EN 60898

STRUCTURE  — EC EN 61439-1

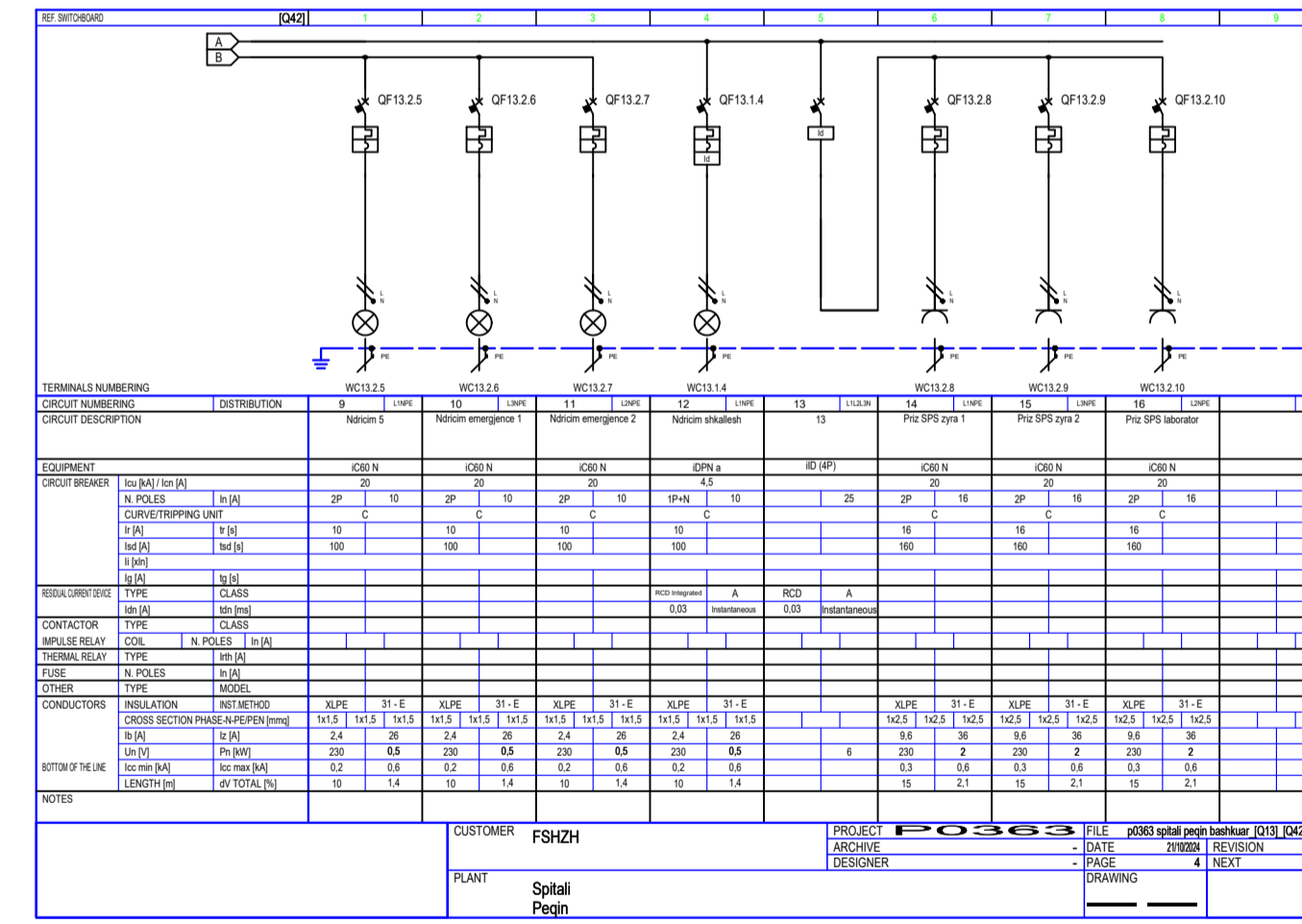
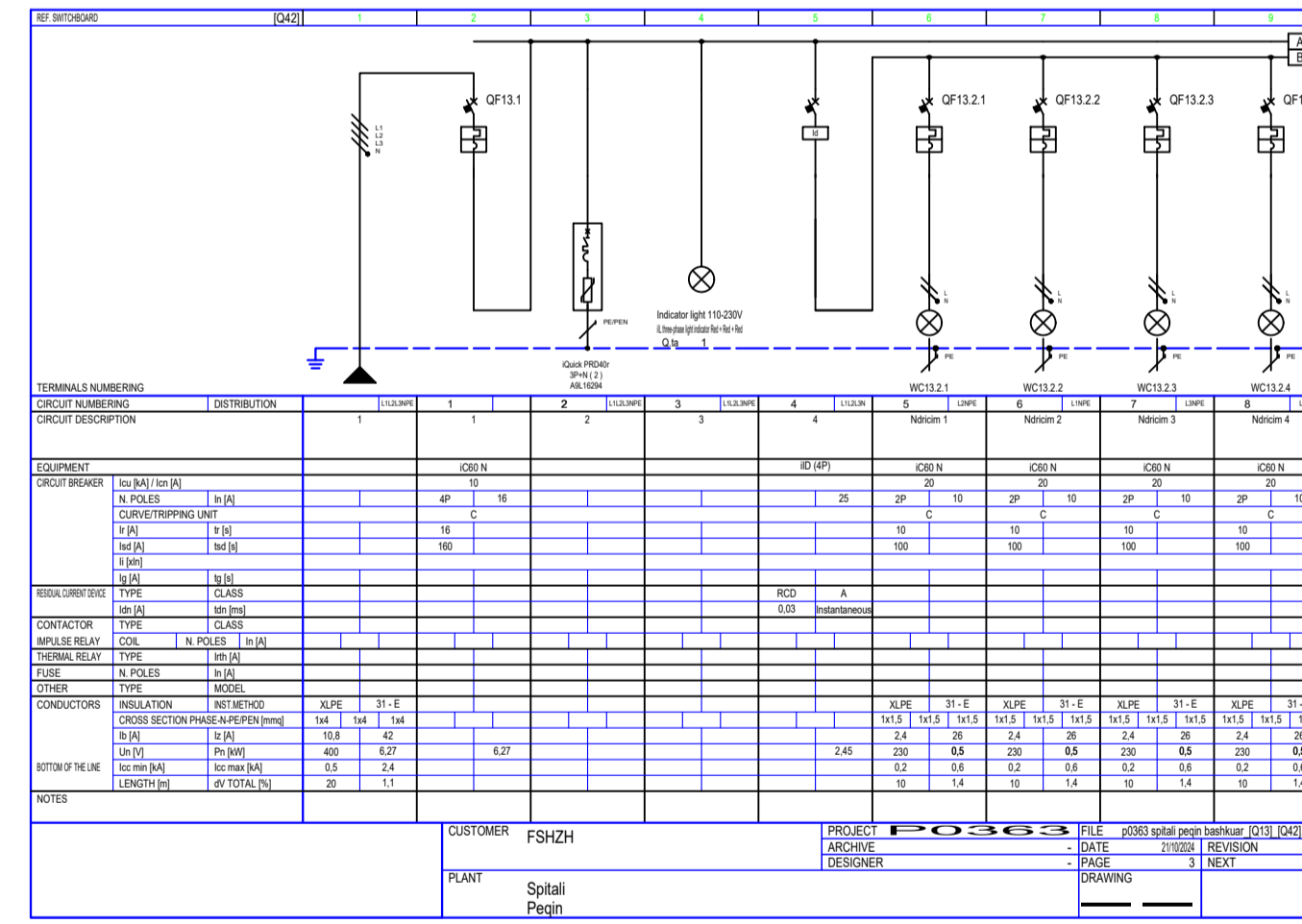

END USER

JOB ORDER

SWITCHBOARD  
SPS QT kat 1

CUSTOMER FSHZH

PLANT Spitali Pëgn

PROJECT ARCHITECT FSHZH

DESIGNER

DATE 10.02.2024

REVISION

DRAWING 1

NEAT

SWITCHBOARD CHARACTERISTICS

UPSTREAM PLANT [D41]

VOLTAGE [V] 400 | FREQ [Hz] 50

SWITCHBOARD RATED CURRENT [A] 2

NEUTRAL SYSTEM TNS

BUSBAR SIZE In [A] Icc [kA]

STRUCTURE

INSULATION CLASS IP

REFERENCE STANDARD

MINI-CIRCUIT BREAKERS  — EC EN 60897-2

MINIATURE CIRCUIT BREAKERS  — EC EN 60898

STRUCTURE  — EC EN 61439-1

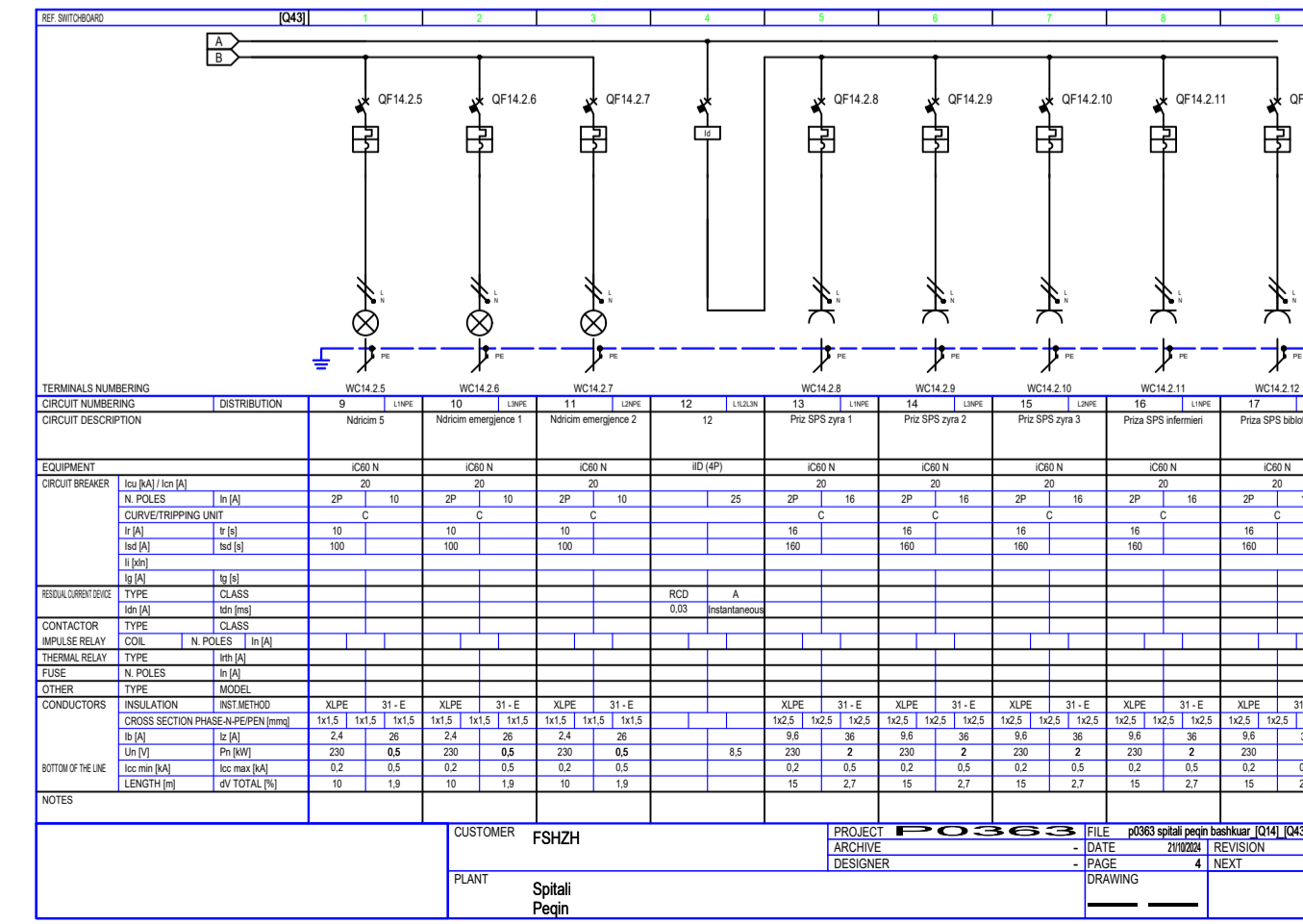
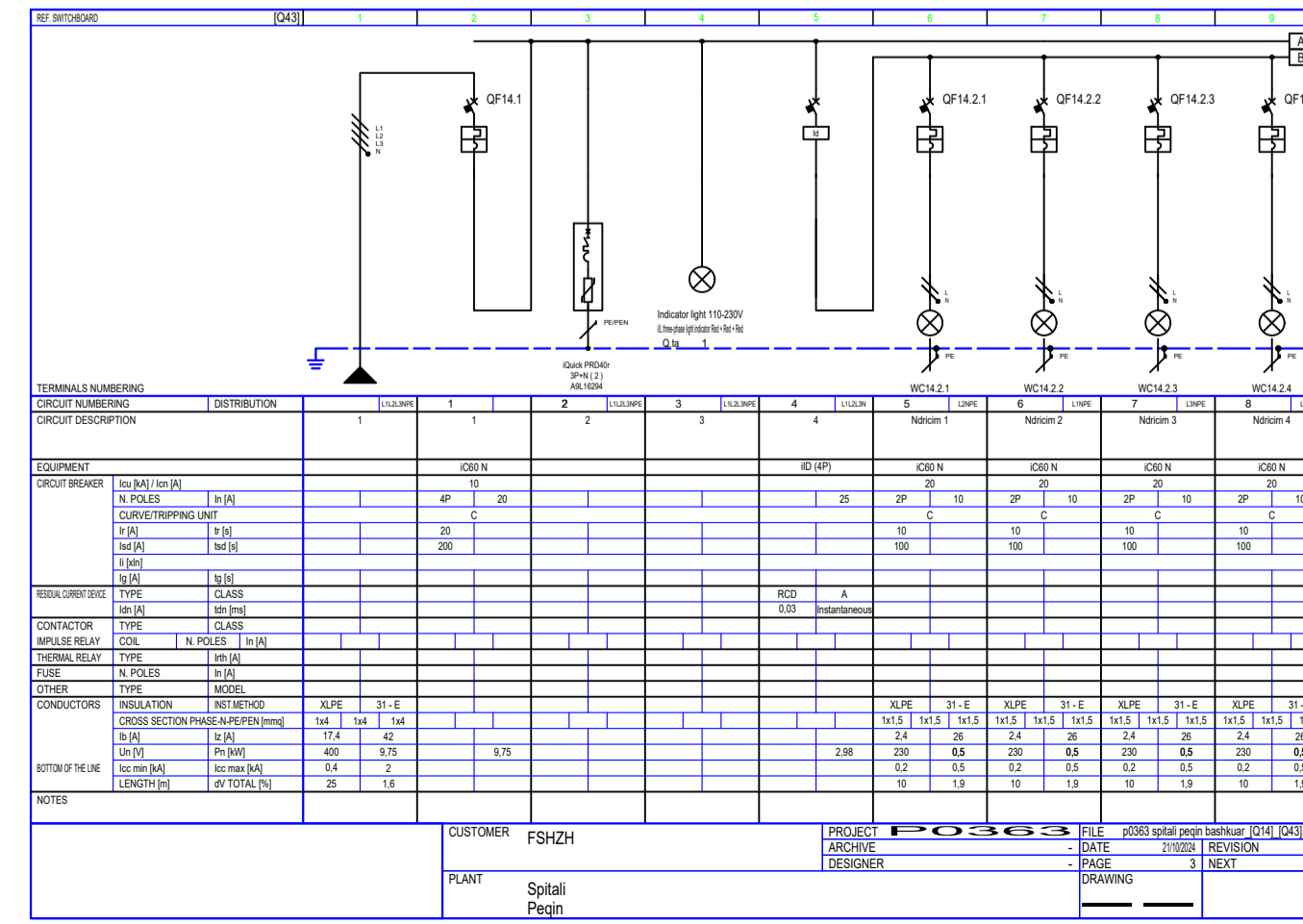

00	Tetor 2024	Projekt Lejë	SHENIM / PERSHKRIM		
RISH. NR.	DATA	QELIMI I DOREZIMIT	SHENIM / PERSHKRIM		
INVESTITORI					
KONSULENTI INXHINIERIK					
Nr. Licencës: N.5221/16					
Përgatiti:	Arkitekt	Edmond MANAHASA	A.0903/2		
	Ing. Strukturist	Anila SPAHIU	K.1068/4		
	Ing. Strukturist	Alda VOKA	K.1340/2		
	Ing. Hidroteknik	Artjola ZOTAJ	K.3443		
	Ing. Hidroteknik	Silvia GJONAJ			
	Ing. Hidroteknik	Anzheta BICI	K.3452		
	Ing. Elektrik	Enis HAVERIKU	E.1450		
	Ing. Elektrik	Ilber PUCI			
	Ing. Mekanik	Marsel PYLLA	M.1288/1		
Kontrolloi:	Ing. Mekanik	Besnik KARAJ	M.0256/2		
	Koordinator Projekti	Abdurrahman SPAHIU	K.1571/5		
	Ing. Strukturist	Taulant KARRIQI	K.1547/6		
	Ing. Elektrik	Emira BERRISHA	E.0550/4		
Miratoi:	Drejues Projekti	Oset HAXHIU	K.1619/5		
TITULLI I PROJEKTTIT					
<b>INVESTIME PILOT PËR TRANSFORMIMIN E INFRASTRUKTURËS SË SHËRBIMEVE DHE RRTJES SË STANDARDIT TË JETËS NË KOMUNITET</b> <b>Objekti: Ndërrhyrje për rikonstrukcionin e spitalit të Peqinit dhe ndryshim i pjesshëm i funksionit të tij</b>					
EMRI I DOKUMENTIT					
<b>SKEMAT ELEKTRIKE TË FURNIZIMIT ME ENERGIJË ELEKTRIKE DHE MBOJTJES SË PAJISJVE ELEKTRIKE / SINGLE LINE DIAGRAMS OF ELECTRICAL ENERGY SUPPLY AND PROTECTION OF ELECTRICAL EQUIPMENT</b>					
FAZA E PROJEKTTIT	Nr. i Dokumentit	Shkalla	Rishikimi	Përmasa e fletës	Fleta
PROJEKT LEJË	E-02	-	00	A1 (841x594mm)	6/10

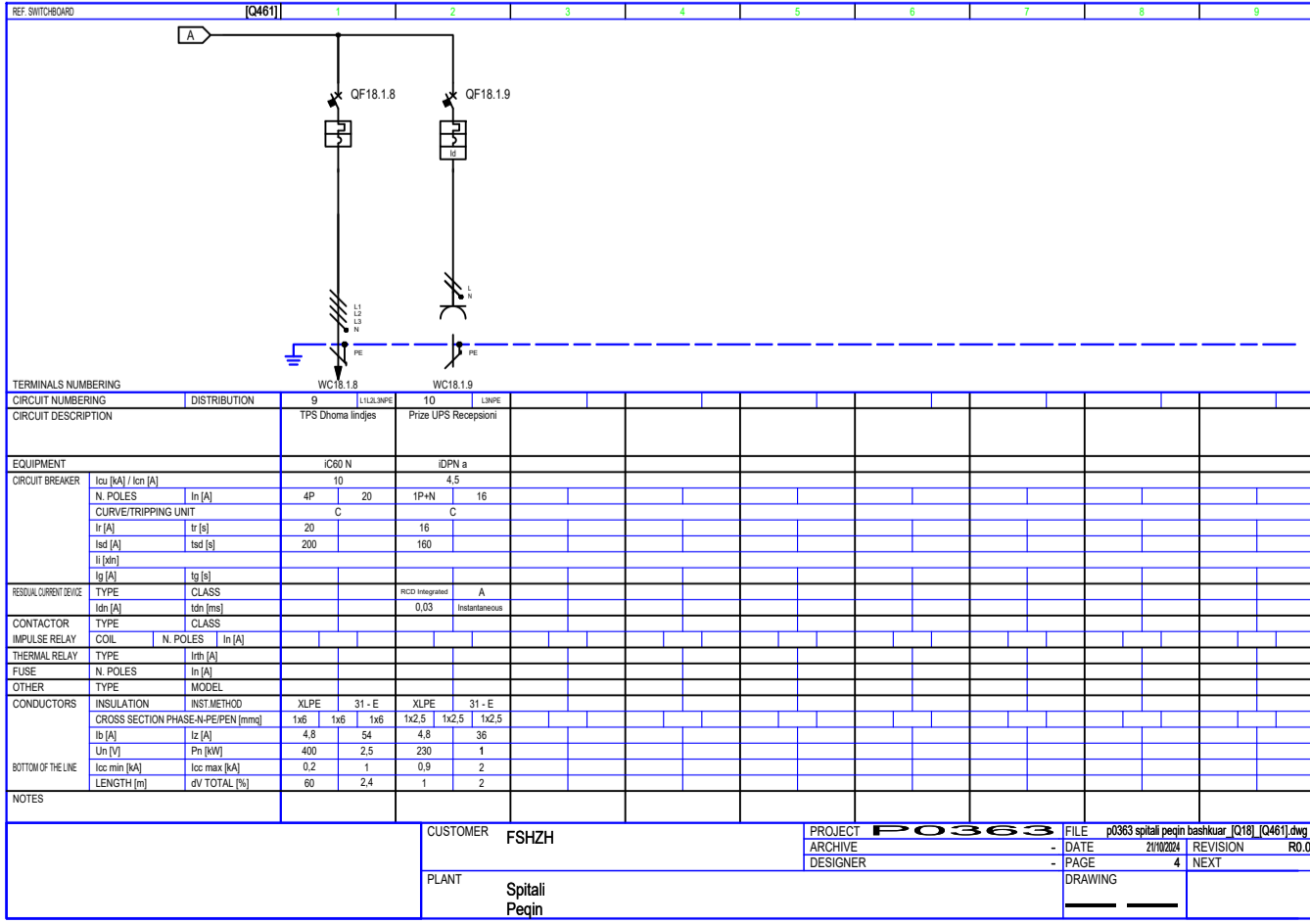
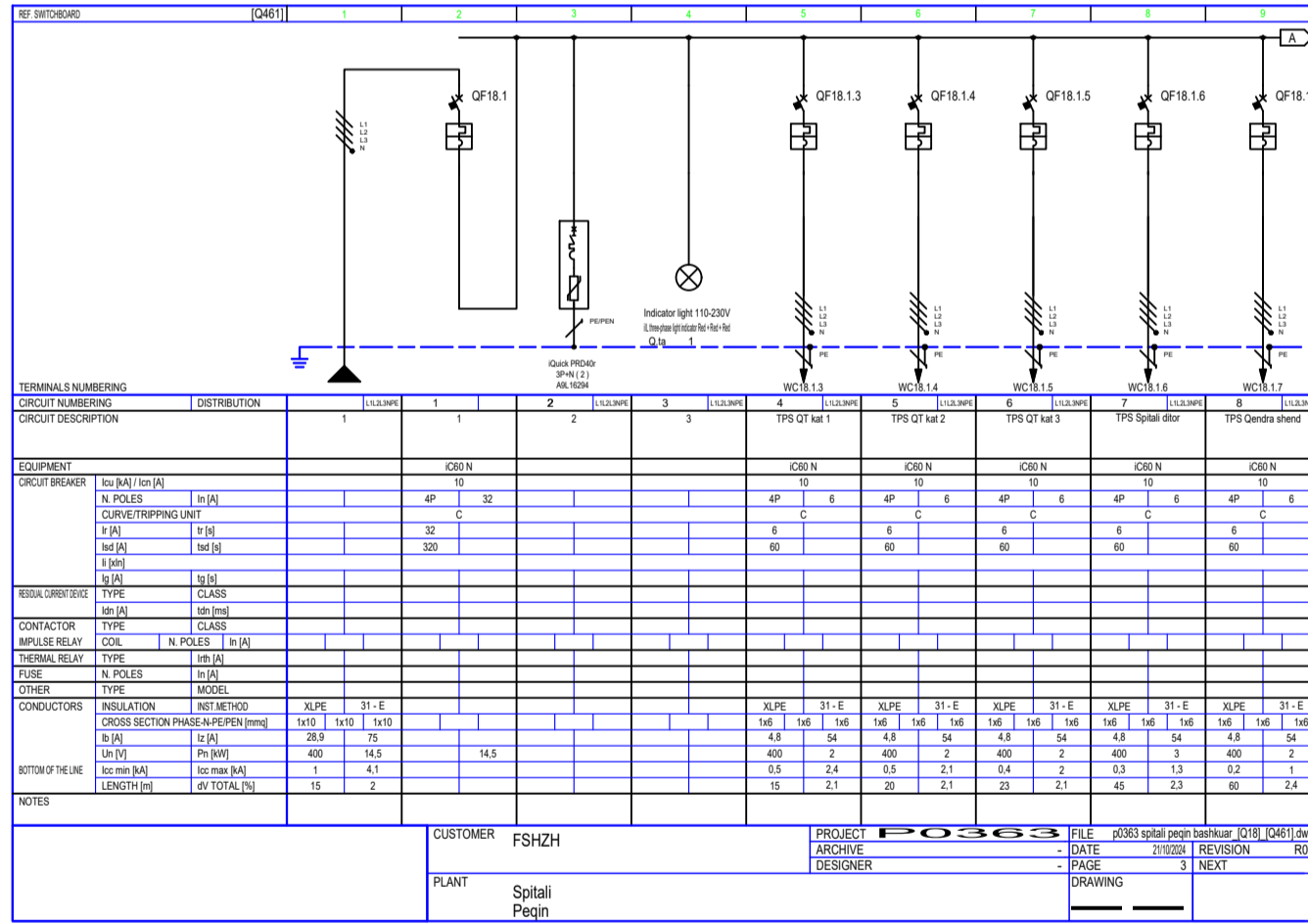
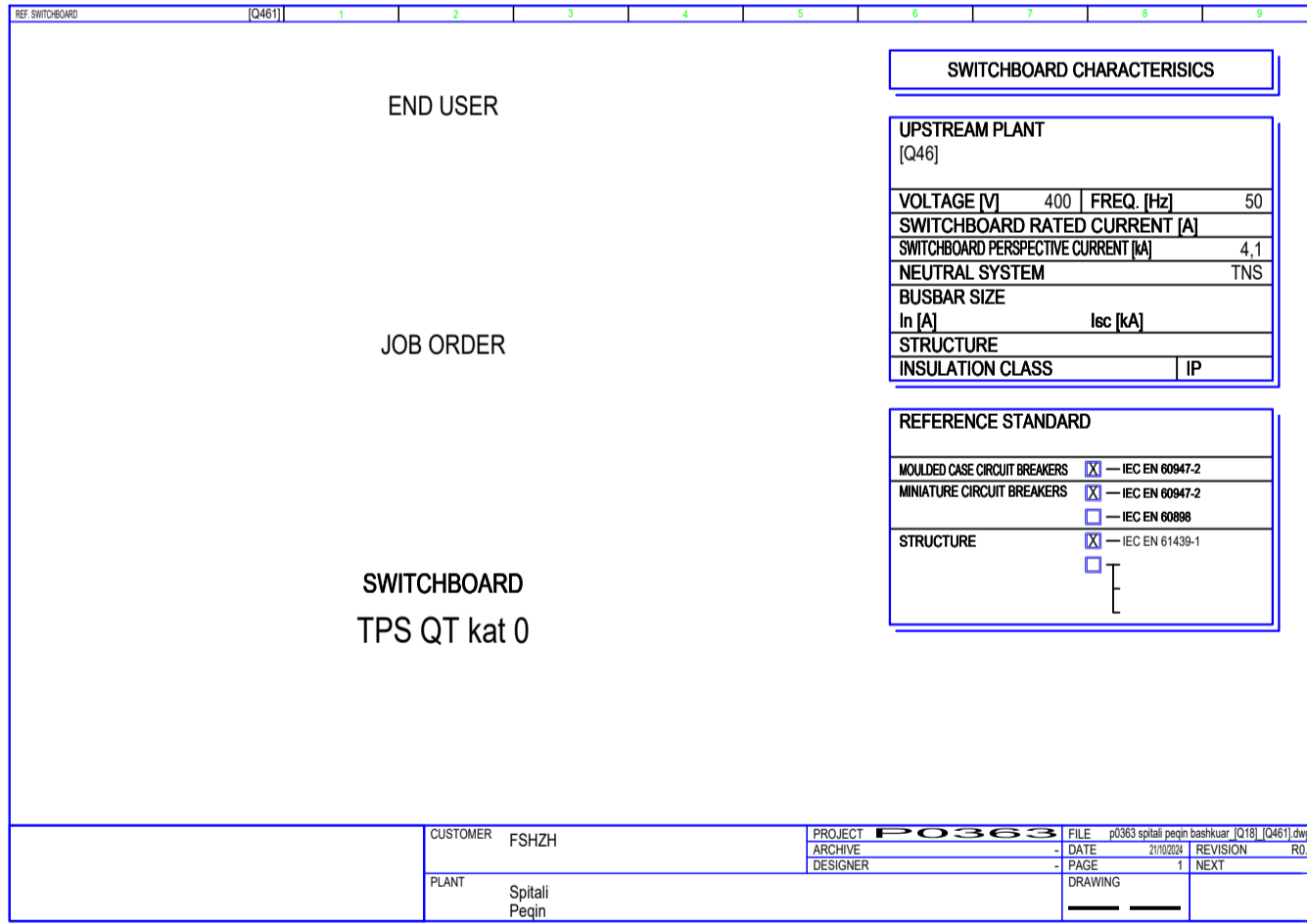
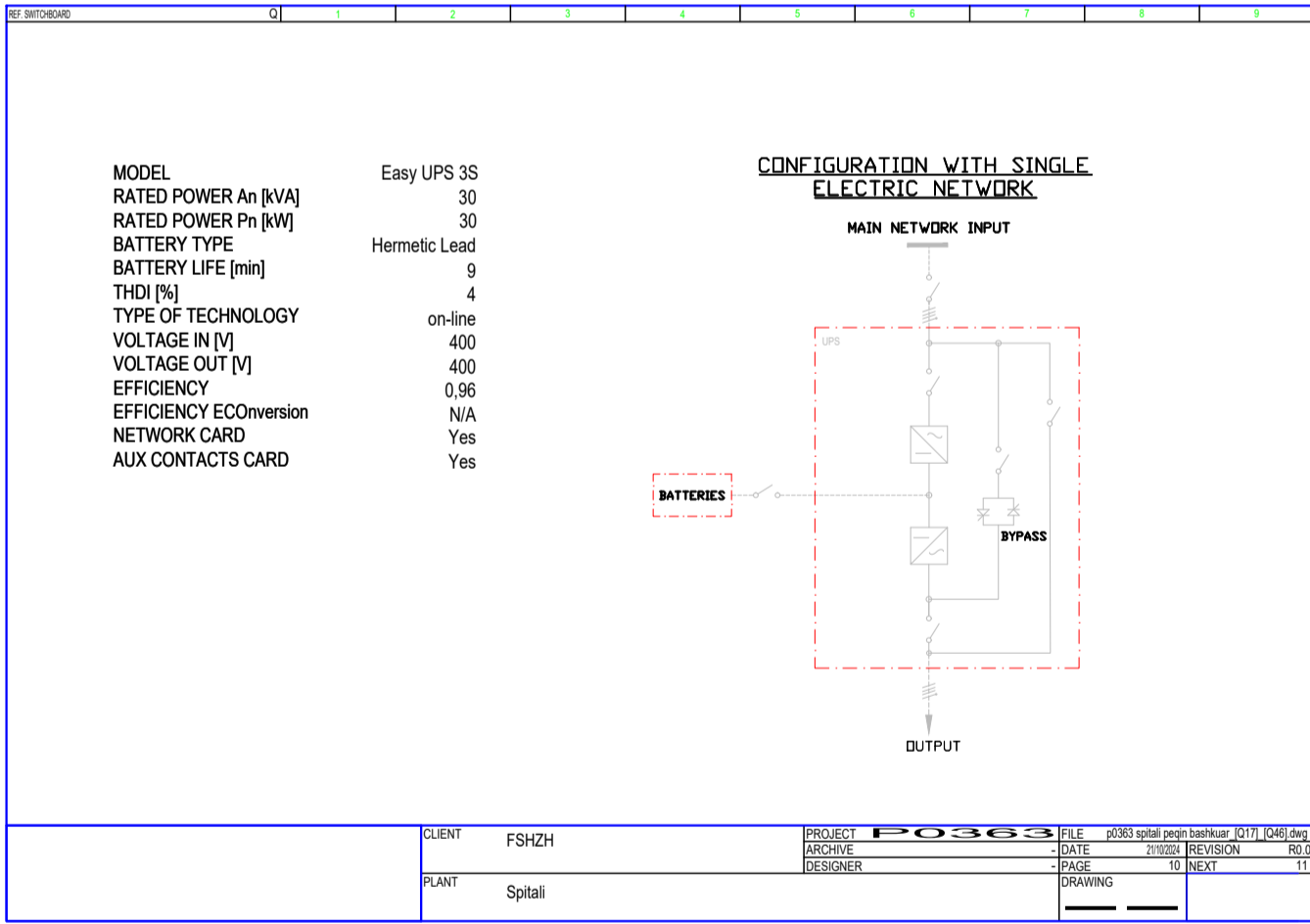
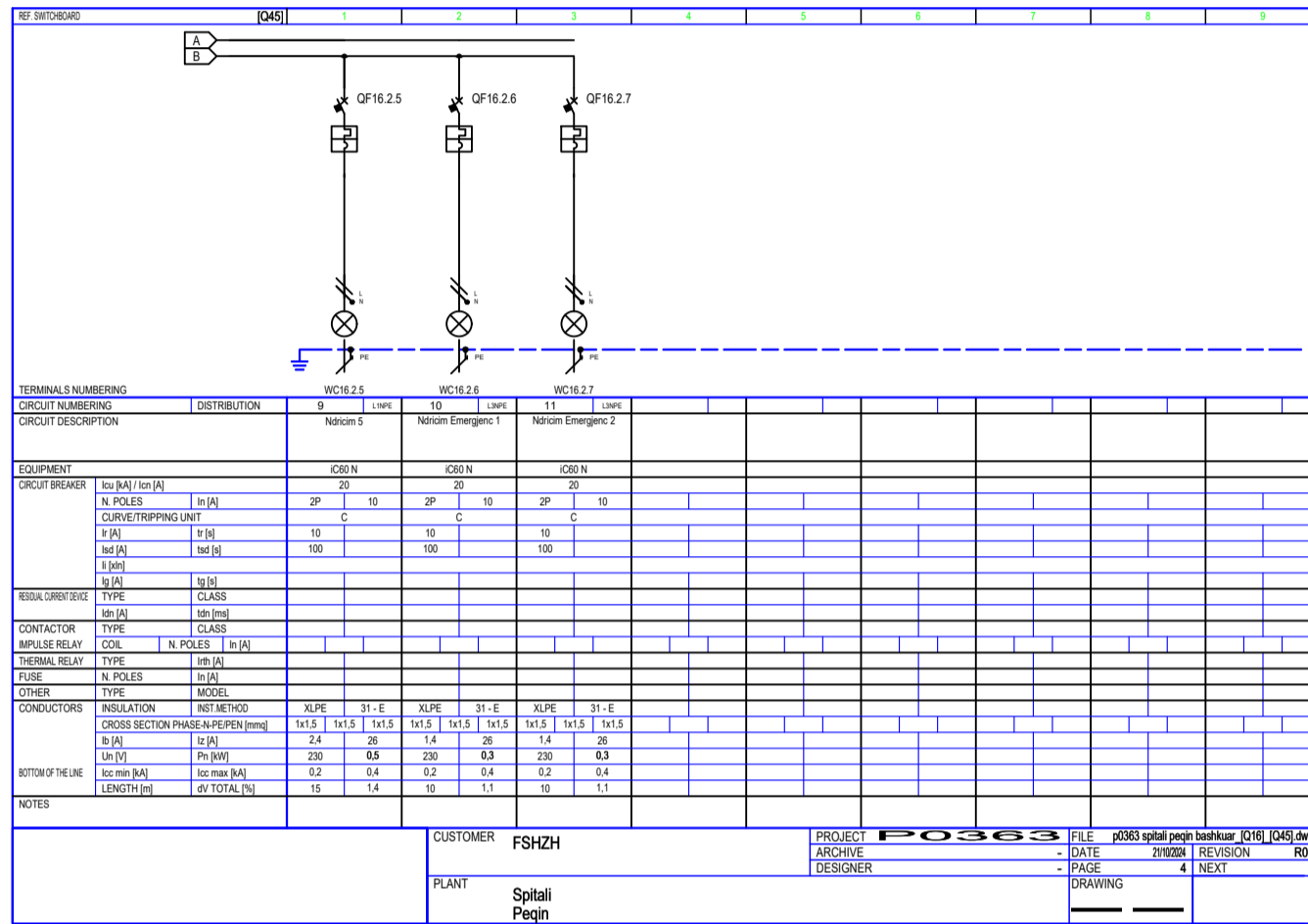
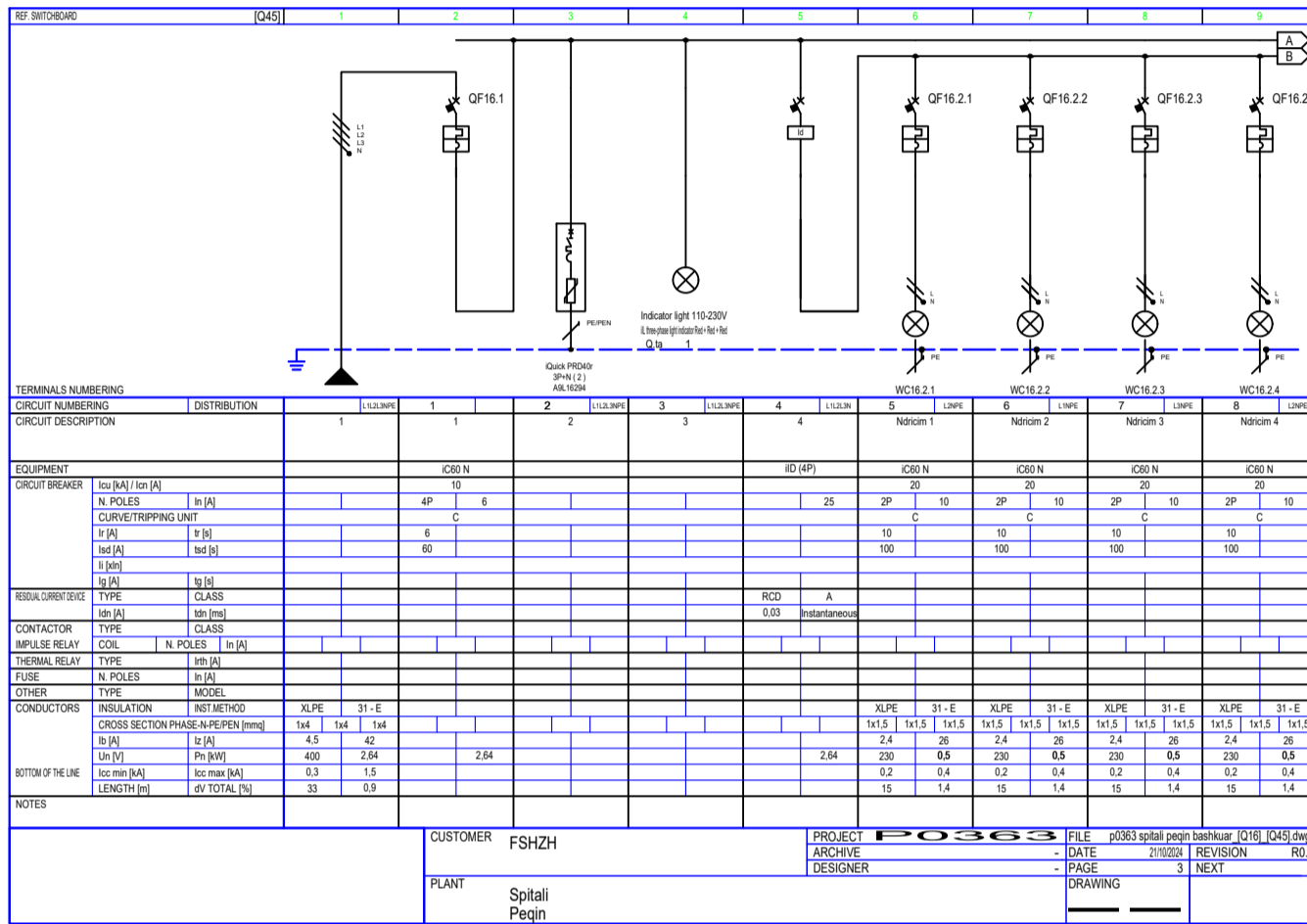
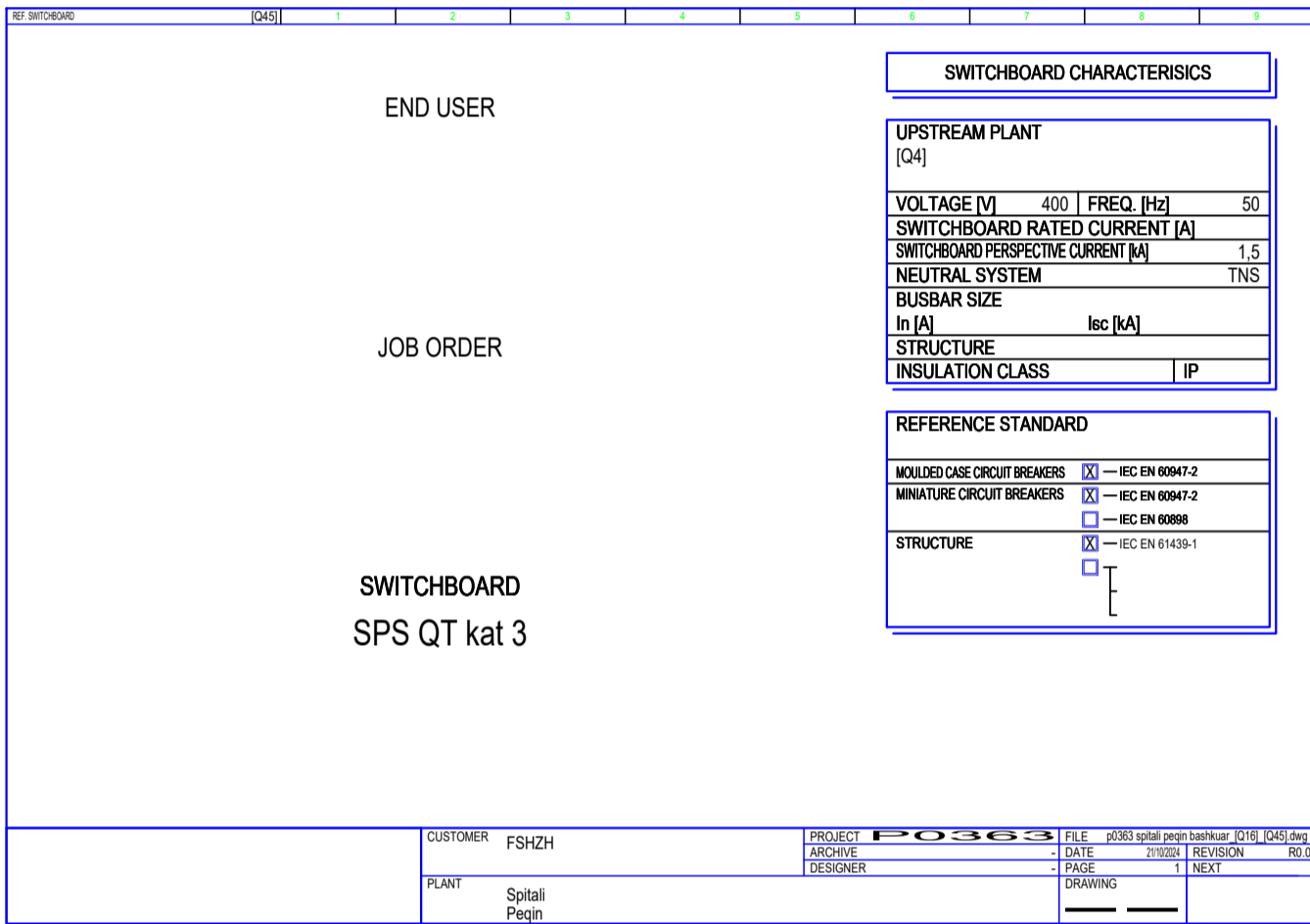
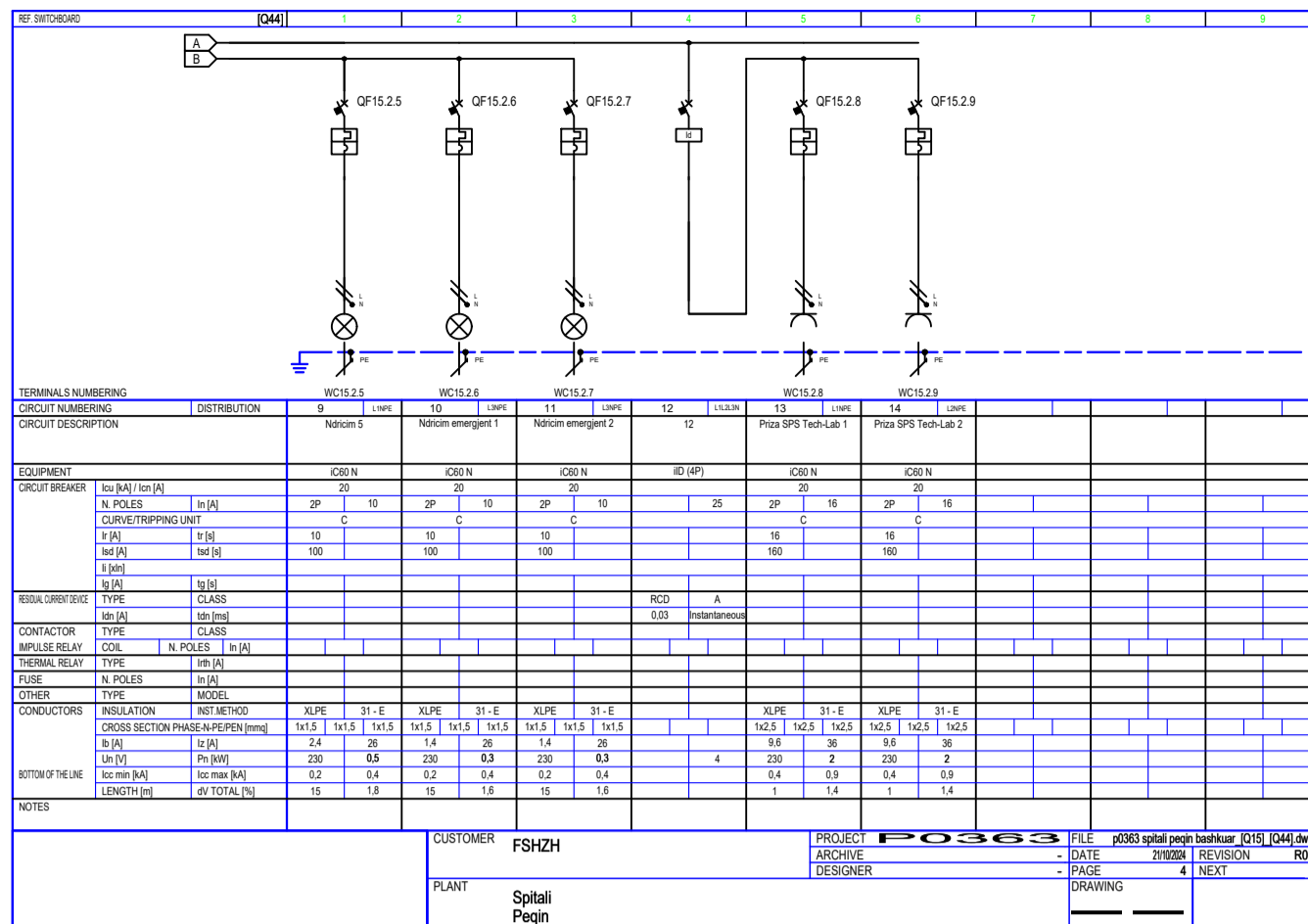
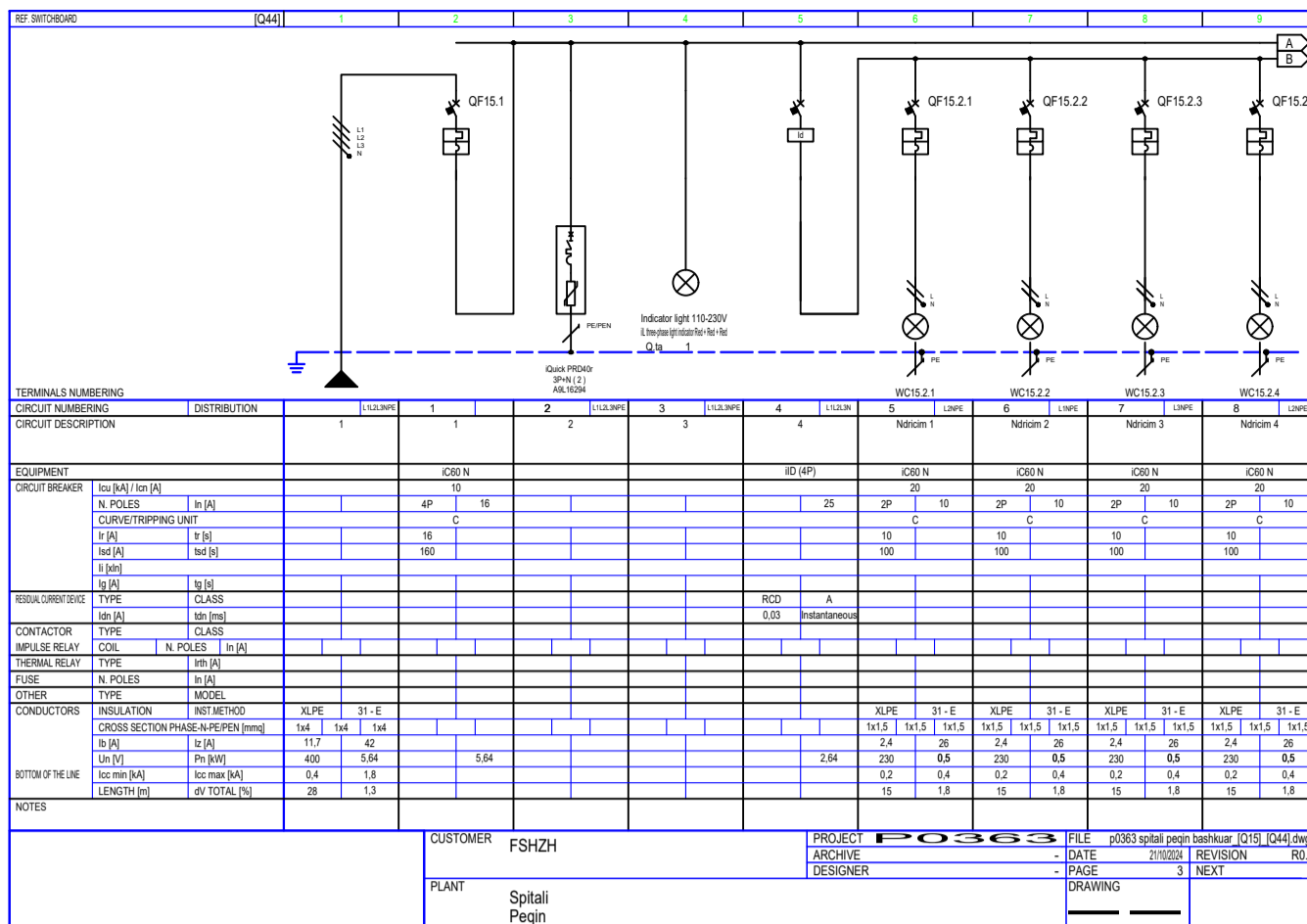
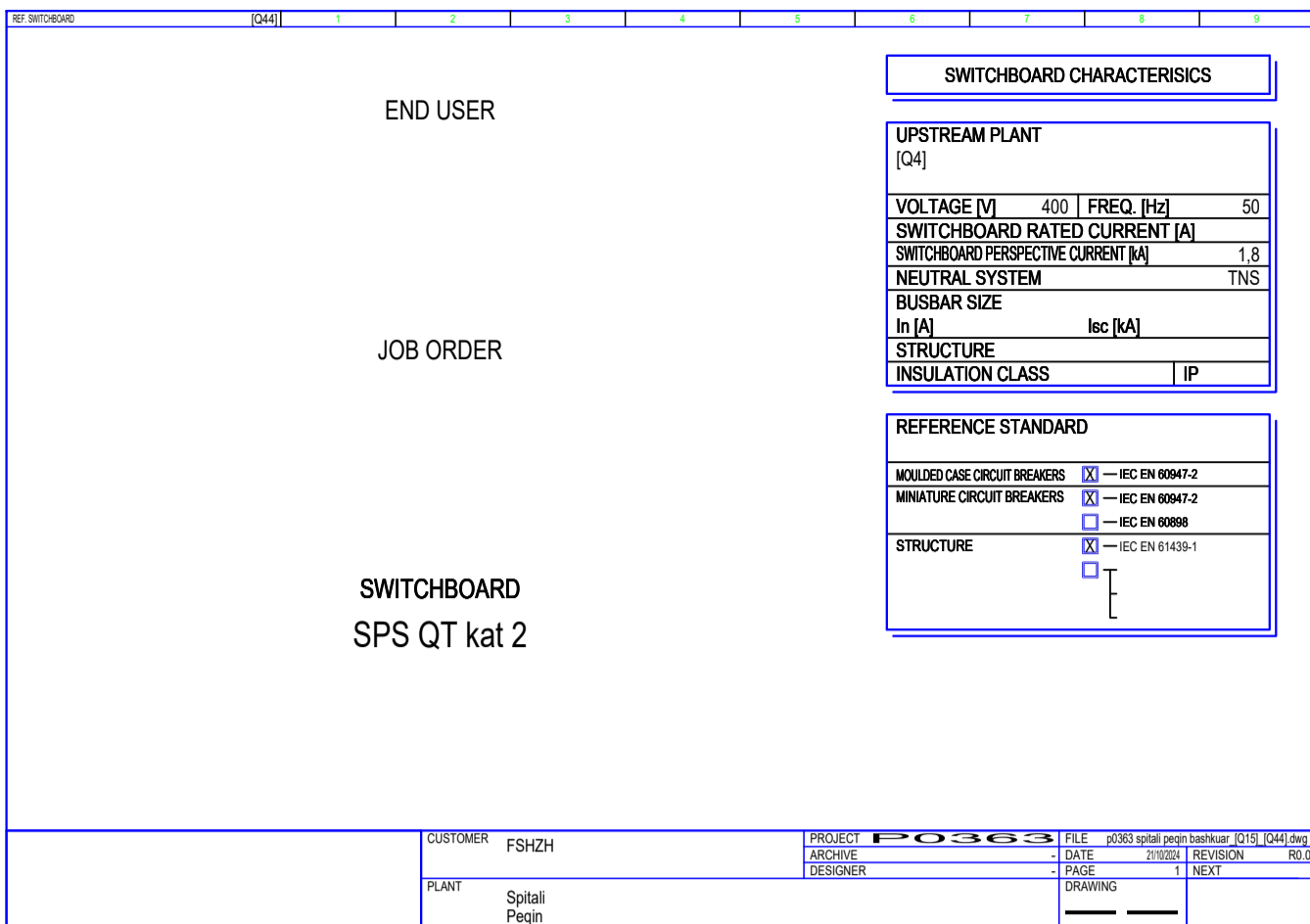

00	Tetor 2024	Projekt Leje		
RISH. NR.	DATA	QELIMI I DOREZIMIT		SHENIM / PERSHKRIM

**INVESTITORI**

**FONDI SHOPTAR IZHVILLIMIT**

**KONSULENTI INXHINIERIK**

**ILLYRIAN CONSULTING ENGINEERS**  
 Adresa: Rr. "Bani Frashot", Pallat: "Hogos", Kat: 11, Tiranë, SHQIPËRI  
 Tel/Fax: +355 4 200 970, E-mail: info@ice-sh.org, www.ice-sh.org

Nr. Licencës: N.5221/16

Përgatiti:	Emri	Nr. Licensës	Firma
Arktekt	Edmond MANAHASA	A.0903/2	
Ing. Strukturist	Anila SPAHIU	K.1068/4	
Ing. Strukturist	Alda VOKA	K.1340/2	
Ing. Hidroteknik	Artjola ZOTAJ	K.344/3	
Ing. Hidroteknik	Silvia GJONAJ		
Ing. Hidroteknik	Anzheta BICI	K.345/2	
Ing. Elektrik	Enis HAVERIKU	E.145/0	
Ing. Elektrik	Ilber PUCI		
Ing. Mekanik	Marsel PYLLA	M.1288/1	

Kontroloi:	Emri	Nr. Licensës	Firma
Ing. Mekanik	Besnik KARAJ	M.0256/2	
Koordinator Projekti	Abdurrahman SPAHIU	K.1571/5	
Ing. Strukturist	Taulant KARRIQI	K.1547/6	
Ing. Elektrik	Emira BERISHA	E.0550/4	

Miratoi:	Emri	Nr. Licensës	Firma
Drejtes Projekti	Oset HAXHIU	K.1619/5	

**TITULLI I PROJEKTT**  
**INVESTIME PILOT PËR TRANSFORMIMIN E INFRASTRUKTURËS SË SHËRBIMEVE DHE RRTJES SË STANDARDIT TË JETËS NË KOMUNITET**  
**Objekti: Ndërrhyrje për rikonstruksionin e spitalit të Peqinit dhe ndryshim i pjesshëm i funksionit të tij**

**EMRI I DOKUMENTIT**

**SKEMAT ELEKTRIKE TË FURNIZIMIT ME ENERGIJË ELEKTRIKE DHE MBOJTJES SË PAJISJIVE ELEKTRIKE / SINGLE LINE DIAGRAMS OF ELECTRICAL ENERGY SUPPLY AND PROTECTION OF ELECTRICAL EQUIPMENT**

FAZA E PROJEKTT	Nr. i Dokumentit	Shkalla	Rishikimi	Përmasa e fletës	Fleta
PROJEKT LEJE	E-02	-	00	A1 (841x594mm)	7/10

END USER

JOB ORDER

SWITCHBOARD  
TPS QT kat 1

**SWITCHBOARD CHARACTERISTICS**

UPSTREAM PLANT (Q461)

VOLTAGE [V] 400 | FREQ. [Hz] 50

SWITCHBOARD RATED CURRENT [A] 2,4

SWITCHBOARD PERSPECTIVE CURRENT [A] 2,4

NEUTRAL SYSTEM TNS

BUSBAR SIZE In [A] Icc [kA]

STRUCTURE

INSULATION CLASS IP

---

REFERENCE STANDARD

MOULDED CASE CIRCUIT BREAKERS  IEC EN 60842-2

MINIATURE CIRCUIT BREAKERS  IEC EN 60842-2

IEC EN 60898

STRUCTURE  IEC EN 61439-1

CUSTOMER	FSHQZ	PROJECT	FOSS	FILE	2024.08.01	DATE	2024.08.01	REVISION	001
PLANT	Sptali	DESIGNER		PAGE	1	NEXT			

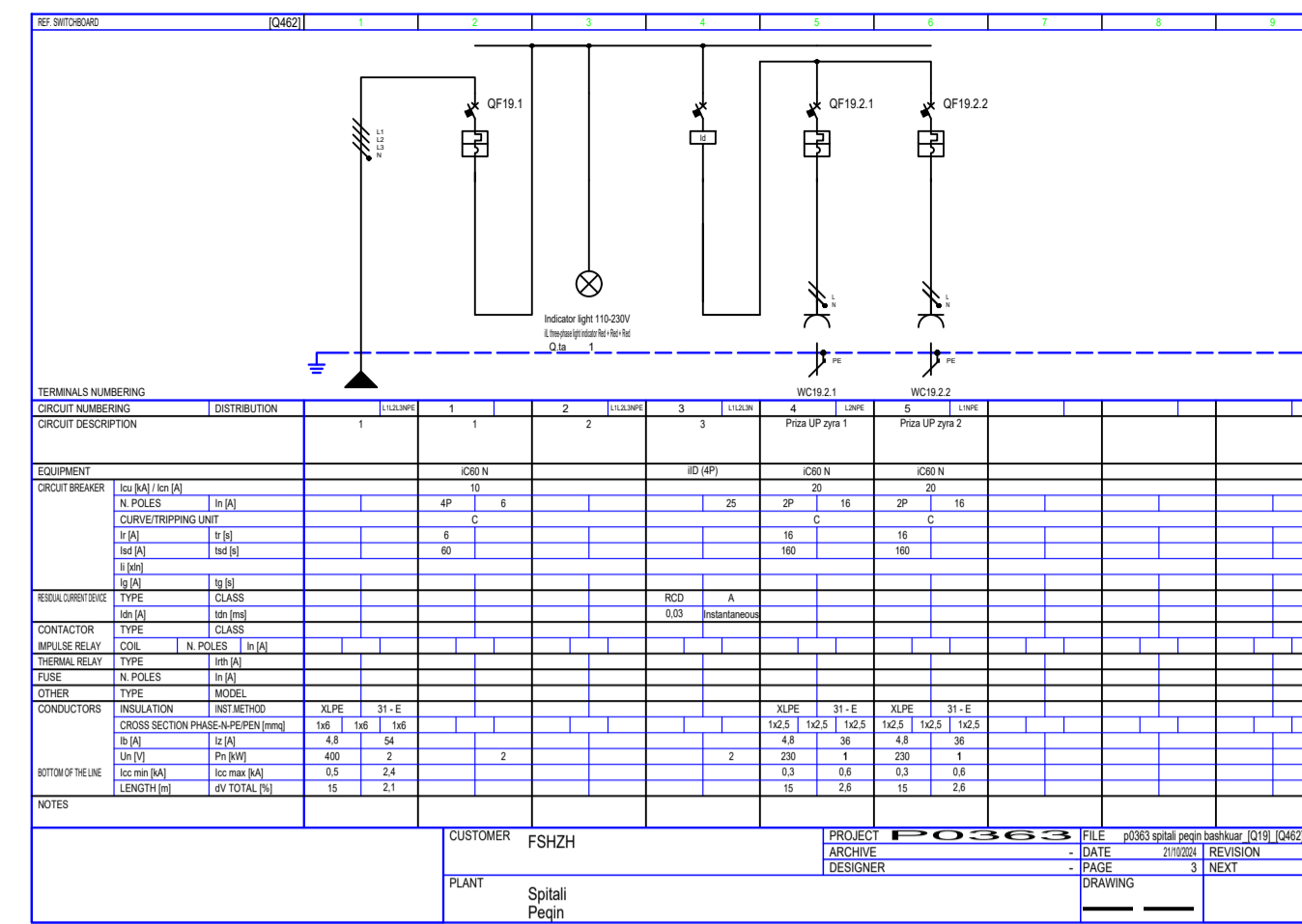

END USER

JOB ORDER

SWITCHBOARD  
TPS QT kat 2

**SWITCHBOARD CHARACTERISTICS**

UPSTREAM PLANT (Q461)

VOLTAGE [V] 400 | FREQ. [Hz] 50

SWITCHBOARD RATED CURRENT [A] 2,4

SWITCHBOARD PERSPECTIVE CURRENT [A] 2,4

NEUTRAL SYSTEM TNS

BUSBAR SIZE In [A] Icc [kA]

STRUCTURE

INSULATION CLASS IP

---

REFERENCE STANDARD

MOULDED CASE CIRCUIT BREAKERS  IEC EN 60842-2

MINIATURE CIRCUIT BREAKERS  IEC EN 60842-2

IEC EN 60898

STRUCTURE  IEC EN 61439-1

CUSTOMER	FSHQZ	PROJECT	FOSS	FILE	2024.08.01	DATE	2024.08.01	REVISION	001
PLANT	Sptali	DESIGNER		PAGE	1	NEXT			

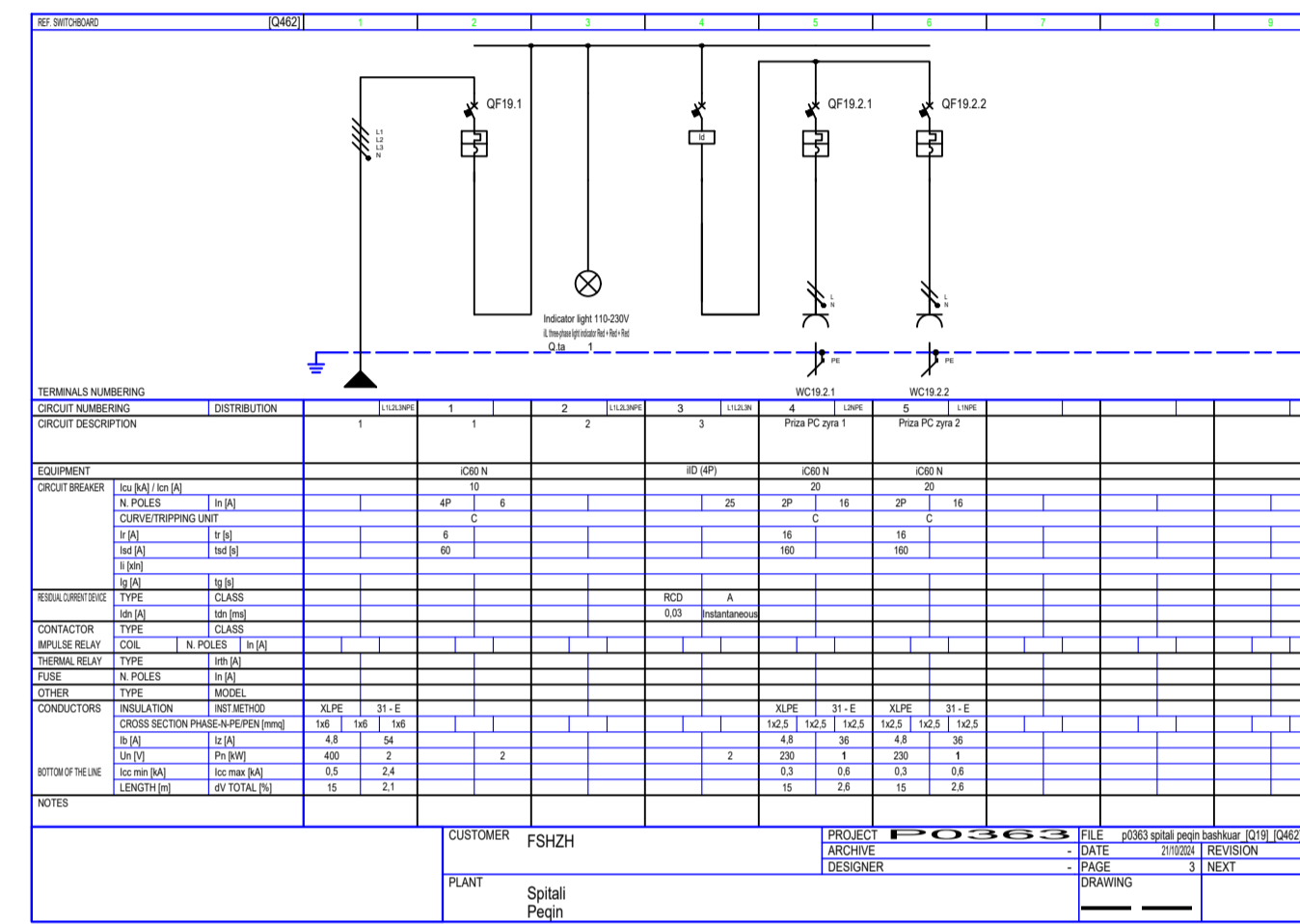

END USER

JOB ORDER

SWITCHBOARD  
TPS QT kat 3

**SWITCHBOARD CHARACTERISTICS**

UPSTREAM PLANT (Q461)

VOLTAGE [V] 400 | FREQ. [Hz] 50

SWITCHBOARD RATED CURRENT [A] 2,4

SWITCHBOARD PERSPECTIVE CURRENT [A] 2,4

NEUTRAL SYSTEM TNS

BUSBAR SIZE In [A] Icc [kA]

STRUCTURE

INSULATION CLASS IP

---

REFERENCE STANDARD

MOULDED CASE CIRCUIT BREAKERS  IEC EN 60842-2

MINIATURE CIRCUIT BREAKERS  IEC EN 60842-2

IEC EN 60898

STRUCTURE  IEC EN 61439-1

CUSTOMER	FSHQZ	PROJECT	FOSS	FILE	2024.08.01	DATE	2024.08.01	REVISION	001
PLANT	Sptali	DESIGNER		PAGE	1	NEXT			

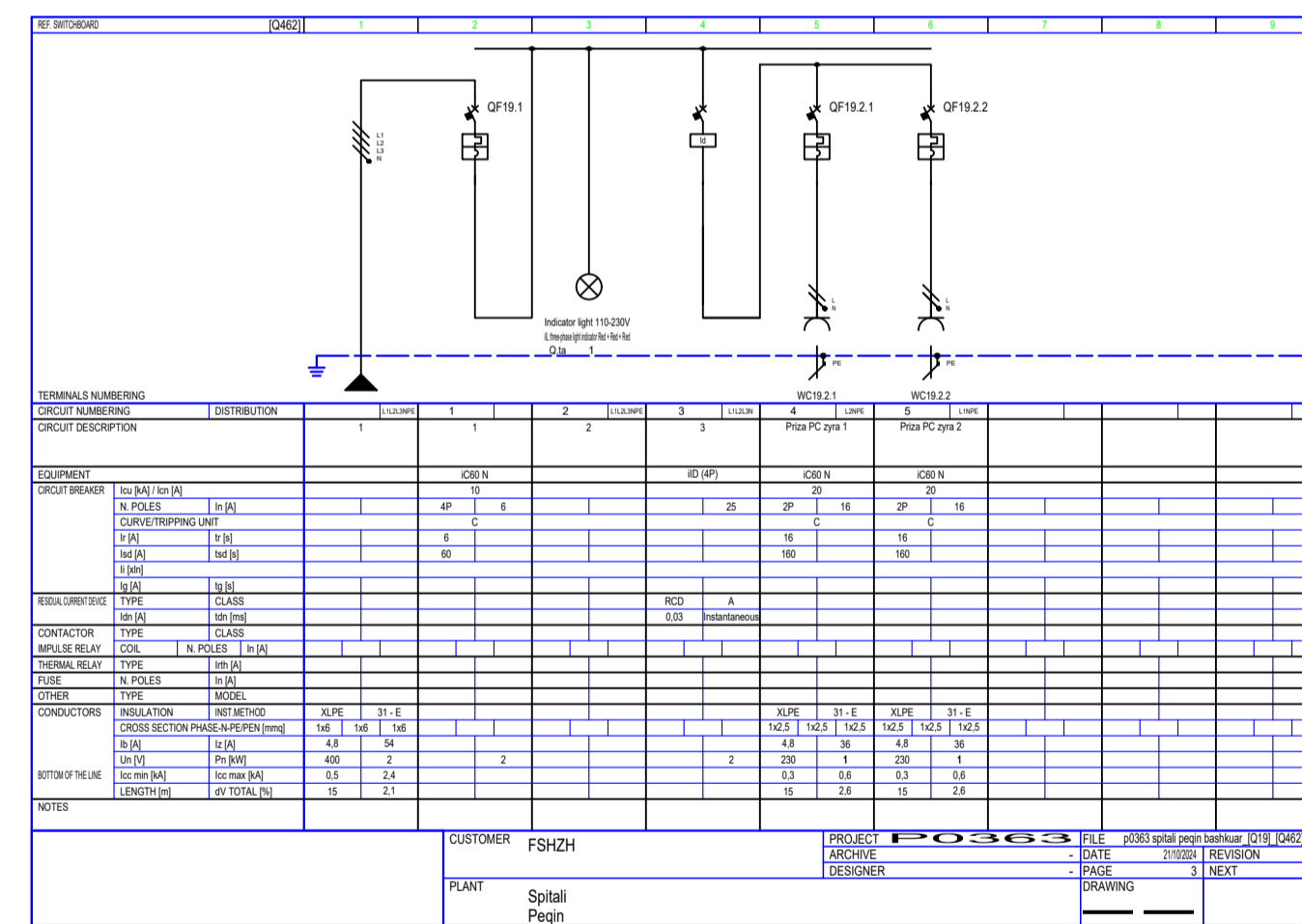

END USER

JOB ORDER

SWITCHBOARD  
TPS Sptali Ditor

**SWITCHBOARD CHARACTERISTICS**

UPSTREAM PLANT (Q461)

VOLTAGE [V] 400 | FREQ. [Hz] 50

SWITCHBOARD RATED CURRENT [A] 1,3

SWITCHBOARD PERSPECTIVE CURRENT [A] 1,3

NEUTRAL SYSTEM TNS

BUSBAR SIZE In [A] Icc [kA]

STRUCTURE

INSULATION CLASS IP

---

REFERENCE STANDARD

MOULDED CASE CIRCUIT BREAKERS  IEC EN 60842-2



MINIATURE CIRCUIT BREAKERS  IEC EN 60842-2

IEC EN 60898

STRUCTURE  IEC EN 61439-1

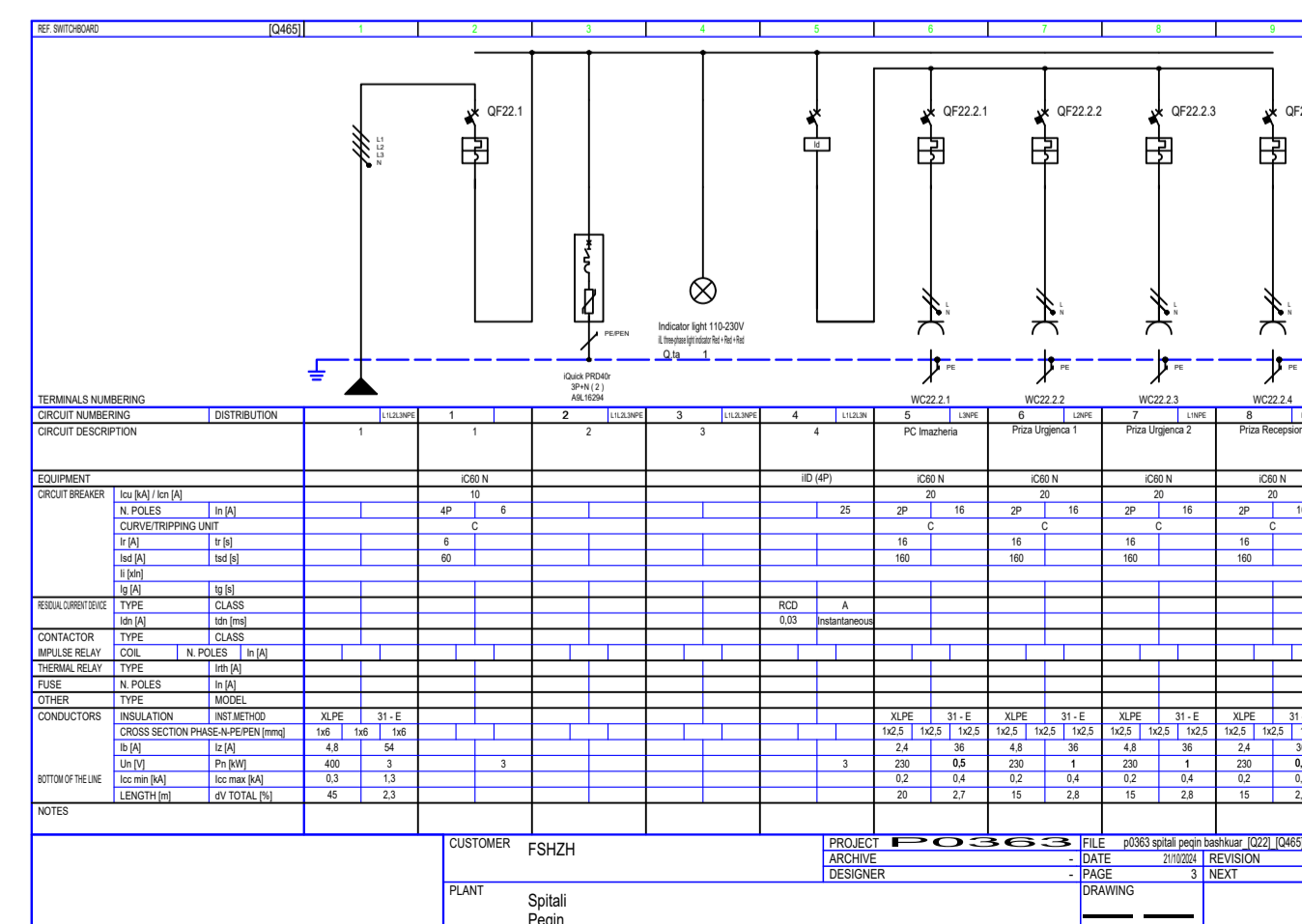
CUSTOMER	FSHQZ	PROJECT	FOSS	FILE	2024.08.01	DATE	2024.08.01	REVISION	001
PLANT	Sptali	DESIGNER		PAGE	1	NEXT			



00 Tetor 2024 Projekt Leje																																												
RISH. NR.	DATA	QELIMI I DOREZIMIT	SHENIM / PERSHKRIM																																									
 <b>FONDI SHOPISTAR I ZHVILLIMIT</b>																																												
KONSULENTI INXHINIERIK																																												
Nr. Licenses: N.5221/16																																												
 <b>ILLYRIAN CONSULTING ENGINEERS</b> Adresa: Rr. "Bani Fishek" Pultat "Bona", Kati 11, Tirane, SHQPERI Tel/Fax: +355 4 200 972 E-mail: info@ice.al www.ice.al																																												
Pergatit:	<table border="1" style="width: 100%; border-collapse: collapse;"> <thead> <tr> <th>pozicioni</th> <th>Emri</th> <th>Nr. Licenses</th> <th>Firma</th> </tr> </thead> <tbody> <tr> <td>Arktekt</td> <td>Edmond MANAHASA</td> <td>A.0903/2</td> <td></td> </tr> <tr> <td>Ing. Strukturist</td> <td>Anila SPAHIU</td> <td>K.1068/4</td> <td></td> </tr> <tr> <td>Ing. Strukturist</td> <td>Aida VOKA</td> <td>K.1340/2</td> <td></td> </tr> <tr> <td>Ing. Hidroteknik</td> <td>Artjola ZOTAJ</td> <td>K.3443</td> <td></td> </tr> <tr> <td>Ing. Hidroteknik</td> <td>Silvia GJONAJ</td> <td></td> <td></td> </tr> <tr> <td>Ing. Hidroteknik</td> <td>Anzhela BICI</td> <td>K.3452</td> <td></td> </tr> <tr> <td>Ing. Elektrik</td> <td>Enis HAVERIKU</td> <td>E.1450</td> <td></td> </tr> <tr> <td>Ing. Elektrik</td> <td>Ilber PUCI</td> <td></td> <td></td> </tr> <tr> <td>Ing. Mekanik</td> <td>Marsel PYLLA</td> <td>M.1288/1</td> <td></td> </tr> </tbody> </table>	pozicioni	Emri	Nr. Licenses	Firma	Arktekt	Edmond MANAHASA	A.0903/2		Ing. Strukturist	Anila SPAHIU	K.1068/4		Ing. Strukturist	Aida VOKA	K.1340/2		Ing. Hidroteknik	Artjola ZOTAJ	K.3443		Ing. Hidroteknik	Silvia GJONAJ			Ing. Hidroteknik	Anzhela BICI	K.3452		Ing. Elektrik	Enis HAVERIKU	E.1450		Ing. Elektrik	Ilber PUCI			Ing. Mekanik	Marsel PYLLA	M.1288/1				
pozicioni	Emri	Nr. Licenses	Firma																																									
Arktekt	Edmond MANAHASA	A.0903/2																																										
Ing. Strukturist	Anila SPAHIU	K.1068/4																																										
Ing. Strukturist	Aida VOKA	K.1340/2																																										
Ing. Hidroteknik	Artjola ZOTAJ	K.3443																																										
Ing. Hidroteknik	Silvia GJONAJ																																											
Ing. Hidroteknik	Anzhela BICI	K.3452																																										
Ing. Elektrik	Enis HAVERIKU	E.1450																																										
Ing. Elektrik	Ilber PUCI																																											
Ing. Mekanik	Marsel PYLLA	M.1288/1																																										
Kontrolit:	<table border="1" style="width: 100%; border-collapse: collapse;"> <tbody> <tr> <td>Ing. Mekanik</td> <td>Besnik KARAJ</td> <td>M.0256/2</td> <td></td> </tr> <tr> <td>Koordinator Projekti</td> <td>Abdurrahman SPAHIU</td> <td>K.1571/5</td> <td></td> </tr> <tr> <td>Ing. Strukturist</td> <td>Taulant KARRIQI</td> <td>K.1547/6</td> <td></td> </tr> <tr> <td>Ing. Elektrik</td> <td>Emira BERSHA</td> <td>E.0550/4</td> <td></td> </tr> </tbody> </table>	Ing. Mekanik	Besnik KARAJ	M.0256/2		Koordinator Projekti	Abdurrahman SPAHIU	K.1571/5		Ing. Strukturist	Taulant KARRIQI	K.1547/6		Ing. Elektrik	Emira BERSHA	E.0550/4																												
Ing. Mekanik	Besnik KARAJ	M.0256/2																																										
Koordinator Projekti	Abdurrahman SPAHIU	K.1571/5																																										
Ing. Strukturist	Taulant KARRIQI	K.1547/6																																										
Ing. Elektrik	Emira BERSHA	E.0550/4																																										
Mirait:	Drejtes Projekt	Oset HAXHIU	K.1619/5																																									
<b>TITULLI I PROJEKTIT</b> <b>INVESTIME PILOT PER TRANSFORMIMIN E INFRASTRUKTURES SE SHERBIMEVE DHE RRTJES SE STANDARDIT TE JETES NE KOMUNITET</b> <b>Objekti: Nderhyrje per rikonstrukcionin e sptalit te Peqinit dhe ndryshim i pjesshem i funksionit te tij</b>																																												
<b>EMRI I DOKUMENTIT</b> <b>SKEMAT ELEKTRIKE TE FURNIZIMIT ME ENERGIJE ELEKTRIKE DHE MBOJTJES SE PAJISJIVE ELEKTRIKE / SINGLE LINE DIAGRAMS OF ELECTRICAL ENERGY SUPPLY AND PROTECTION OF ELECTRICAL EQUIPMENT</b>																																												
FAZA E PROJEKTIT	Nr. i Dokumentit	Shkalla	Rishikimi	Permasa e fletes	Fleta																																							
PROJEKT LEJE	E-02	-	00	A1 (841x594mm)	8/10																																							

END USER

JOB ORDER

SWITCHBOARD  
TPS Qender Shendetore

**SWITCHBOARD CHARACTERISTICS**

UPSTREAM PLANT [Q461]

VOLTAGE [V] 400 | FREQ [Hz] 50

SWITCHBOARD RATED CURRENT [A]

NEUTRAL SYSTEM TNS

BUSBAR SIZE In [A] Icc [kA]

STRUCTURE

INSULATION CLASS IP

**REFERENCE STANDARD**

MINIATURE CIRCUIT BREAKERS  IEC EN 60897-2

MINIATURE CIRCUIT BREAKERS  IEC EN 60897-2

STRUCTURE  IEC EN 61439-1

CUSTOMER FSHQH PROJECT P0363 FILE 2024 total page number 2024\_0461.dwg  
DATE 23/09/2024 REVISION 001  
PLANT Spitali Pjeqin DRAWING 1/1

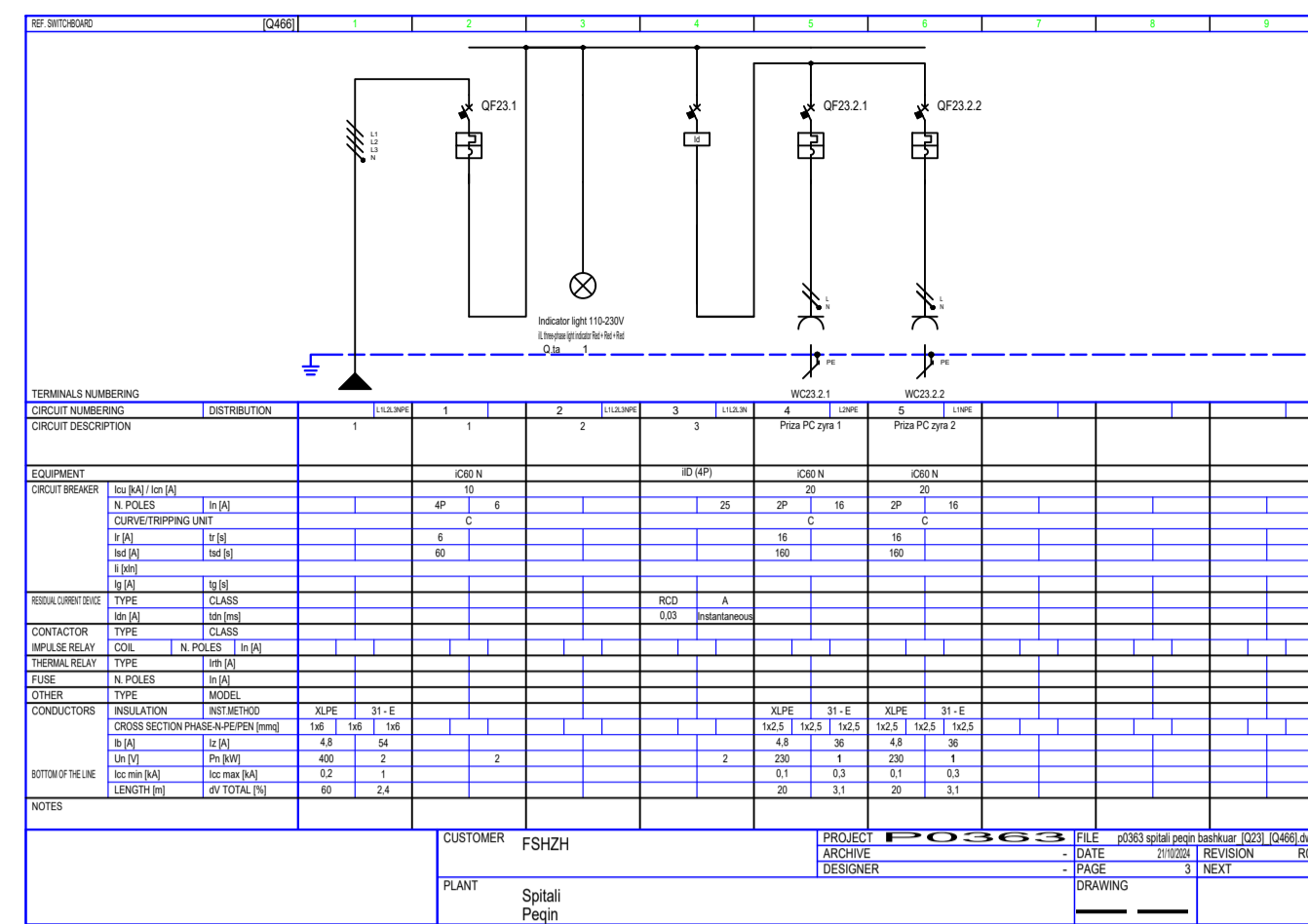

END USER

JOB ORDER

SWITCHBOARD  
Kuder dhome lindje

**SWITCHBOARD CHARACTERISTICS**

UPSTREAM PLANT [Q461]

VOLTAGE [V] 400 | FREQ [Hz] 50

SWITCHBOARD RATED CURRENT [A]

NEUTRAL SYSTEM TNS

BUSBAR SIZE In [A] Icc [kA]

STRUCTURE

INSULATION CLASS IP

**REFERENCE STANDARD**

MINIATURE CIRCUIT BREAKERS  IEC EN 60897-2

MINIATURE CIRCUIT BREAKERS  IEC EN 60897-2

STRUCTURE  IEC EN 61439-1

CUSTOMER FSHQH PROJECT P0363 FILE 2024 total page number 2024\_0461.dwg  
DATE 23/09/2024 REVISION 001  
PLANT Spitali Pjeqin DRAWING 1/1

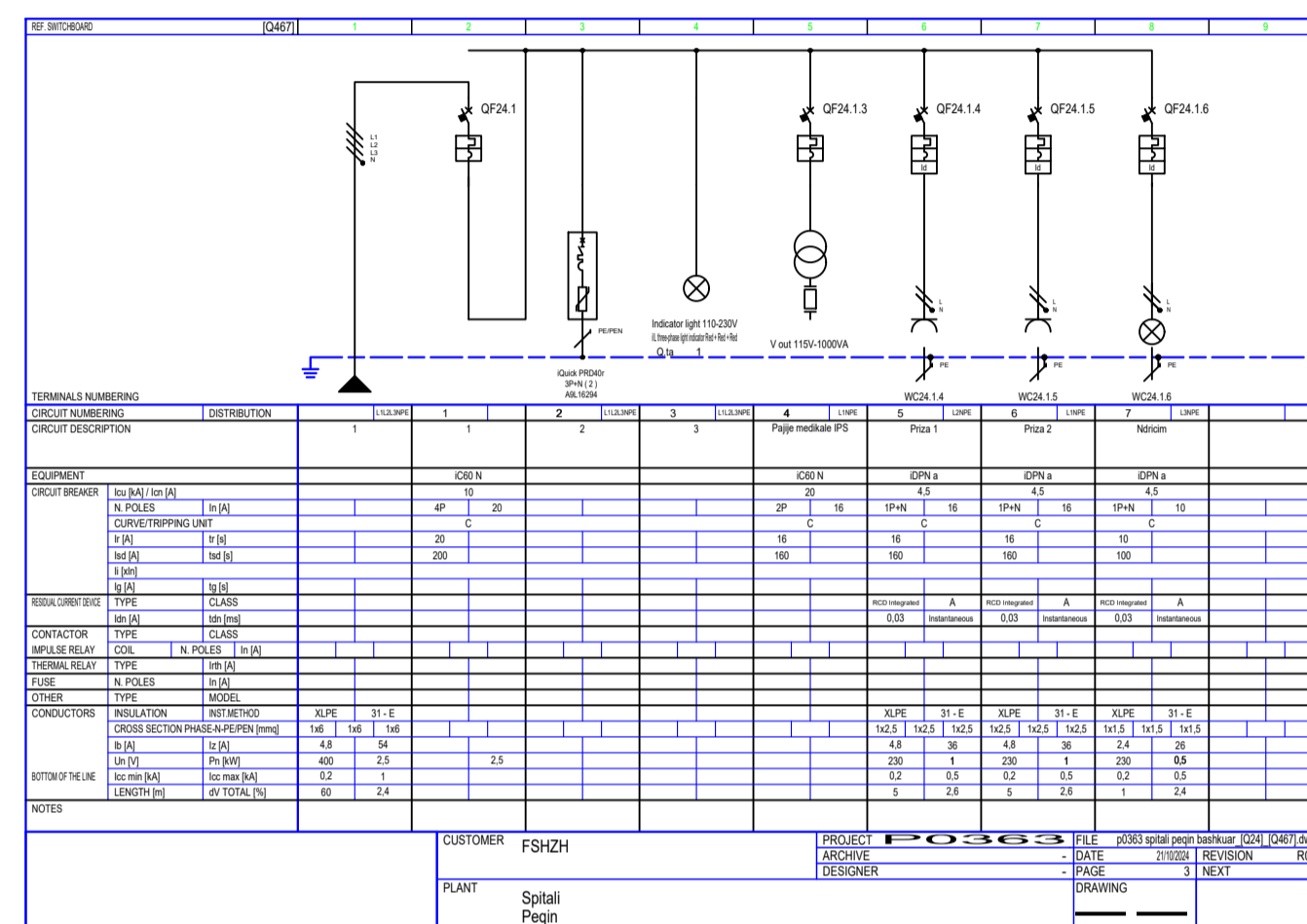

END USER

JOB ORDER

SWITCHBOARD  
SPS Spitali Ditor

**SWITCHBOARD CHARACTERISTICS**

UPSTREAM PLANT [Q4]

VOLTAGE [V] 400 | FREQ [Hz] 50

SWITCHBOARD RATED CURRENT [A] 3.0

NEUTRAL SYSTEM TNS

BUSBAR SIZE In [A] Icc [kA]

STRUCTURE

INSULATION CLASS IP

**REFERENCE STANDARD**

MINIATURE CIRCUIT BREAKERS  IEC EN 60897-2

MINIATURE CIRCUIT BREAKERS  IEC EN 60897-2

STRUCTURE  IEC EN 61439-1

CUSTOMER FSHQH PROJECT P0363 FILE 2024 total page number 2024\_0461.dwg  
DATE 23/09/2024 REVISION 001  
PLANT Spitali Pjeqin DRAWING 1/1

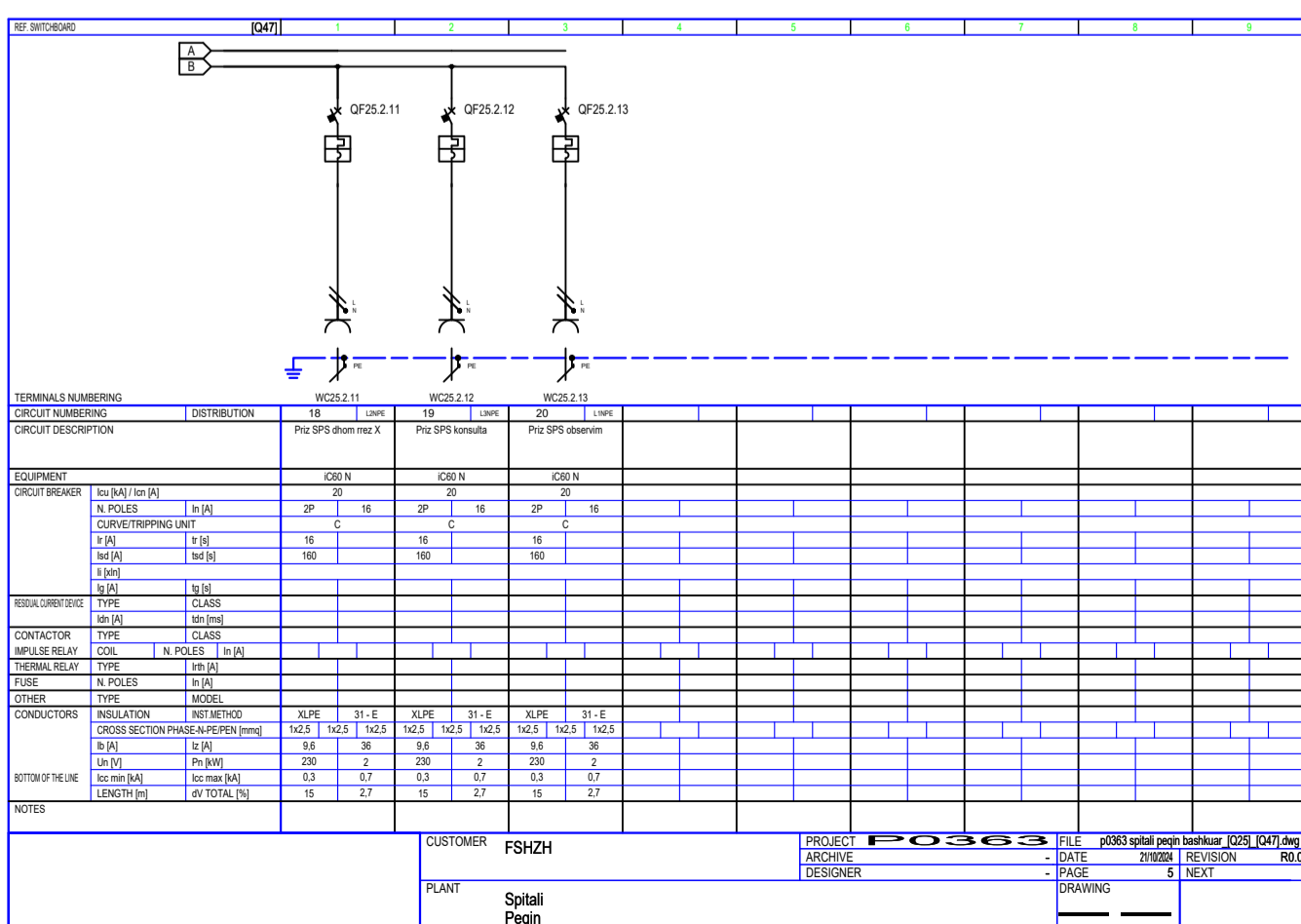
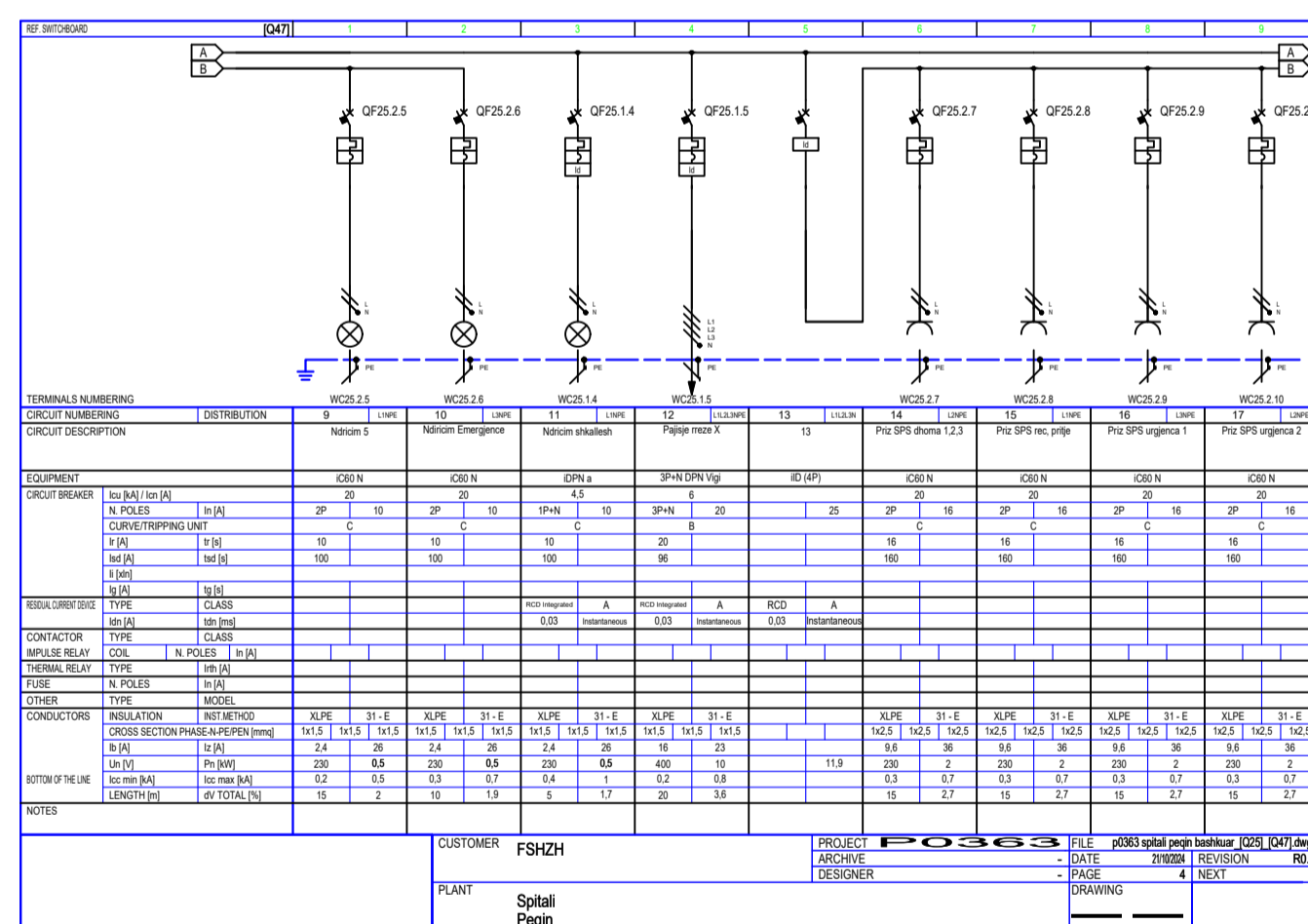
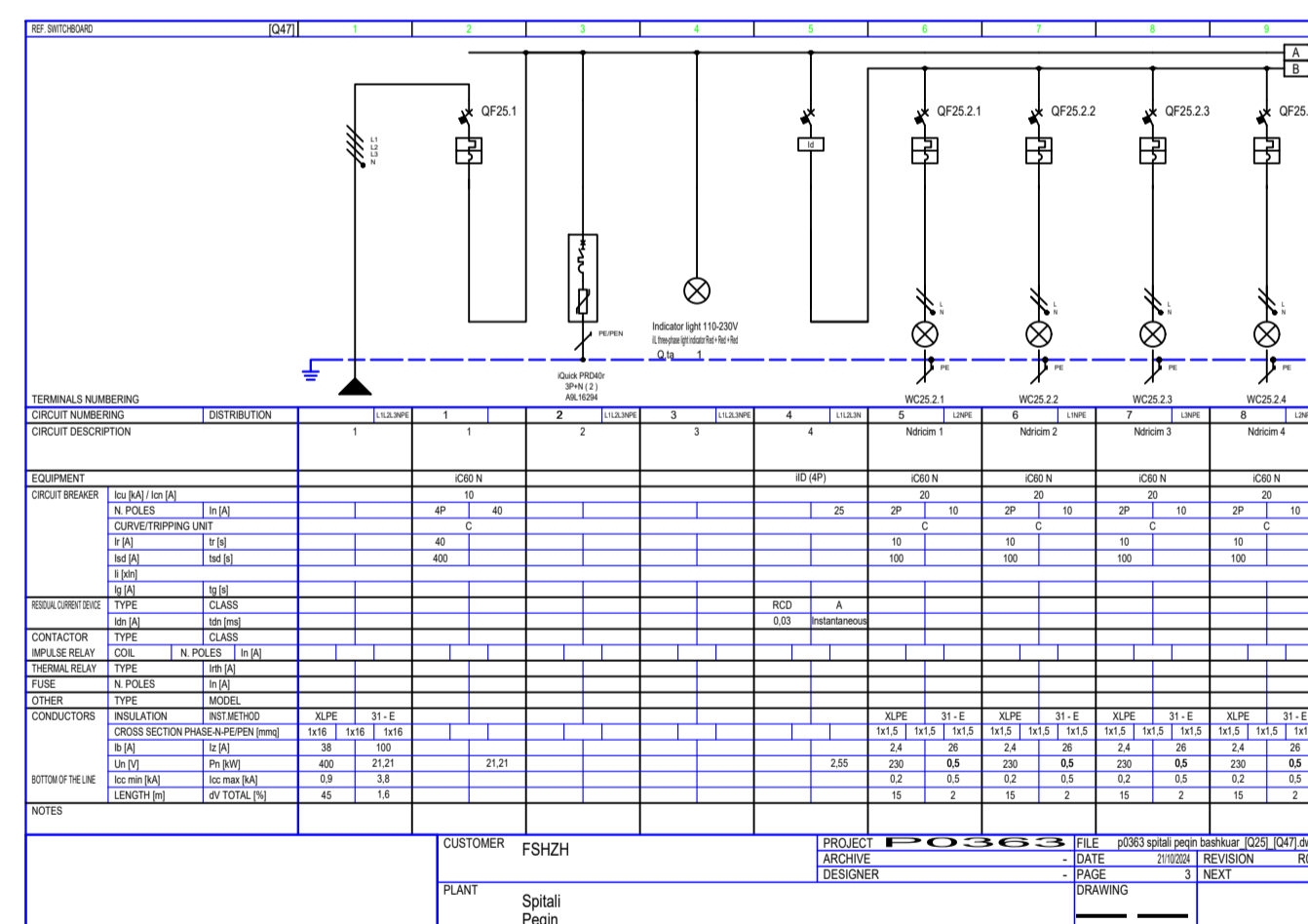

00	Tetor 2024	Projekt Leje	
RISH. NR.	DATA	QELIMI I DOREZIMIT	SHENIM / PERSHKRIM

INVESTITORI

FONDI SHOPTAR I ZHVILLIMIT

KONSULENTI INXHINIERIK

ICE

ILLYRIAN CONSULTING ENGINEERS  
Adresa: Rr. "Bani Frashot", Pallat "Bjeshka", Kati 11, Tirane, SHQPERI  
Telefon: +355 4 200 970 | Email: info@ice.al

Nr. Licencës: N.5221/16

Përgatiti:	pozicioni	Emri	Nr. Licensës	Firma
	Arkitekt	Edmond MANAHASA	A.0903/2	
	Ing. Strukturist	Anila SPAHIU	K.1068/4	
	Ing. Strukturist	Aida VOKA	K.1340/2	
	Ing. Hidroteknik	Artjola ZOTAJ	K.3443	
	Ing. Hidroteknik	Silvia GJONAJ		
	Ing. Hidroteknik	Anzheta BICI	K.3452	
	Ing. Elektrik	Enis HAVERIKU	E.1450	
	Ing. Elektrik	Ilber PUCI		
	Ing. Mekanik	Marsel PYLLA	M.1288/1	
Kontrolloi:	Ing. Mekanik	Besnik KARAJ	M.0256/2	
	Koordinator Projekti	Abdurrahman SPAHIU	K.1571/5	
	Ing. Strukturist	Taulant KARRIOI	K.1547/6	
	Ing. Elektrik	Emira BERSHA	E.0550/4	
Miratoi:	Drejtes Projekt	Oset HAXHIU	K.1619/5	

TITULLI I PROJEKTTIT

**INVESTIME PILOT PËR TRANSFORMIMIN E INFRASTRUKTURËS SË SHËRBIMEVE DHE RRTJES SË STANDARDIT TË JETËS NË KOMUNITET**

Objekti: Ndërrhyrje për rikonstruksionin e spitalit të Peqinit dhe ndryshim i pjesshëm i funksionit të tij

EMRI I DOKUMENTIT

**SKEMAT ELEKTRIKE TË FURNIZIMIT ME ENERGJI ELEKTRIKE DHE MBOJTJES SË PAJISJIVE ELEKTRIKE / SINGLE LINE DIAGRAMS OF ELECTRICAL ENERGY SUPPLY AND PROTECTION OF ELECTRICAL EQUIPMENT**

FAZA E PROJEKTTIT	Nr. i Dokumentit	Shkalla	Rishikimi	Përmasa e fletës	Fleta
PROJEKT LEJE	E-02	-	00	A1 (841x594mm)	9/10



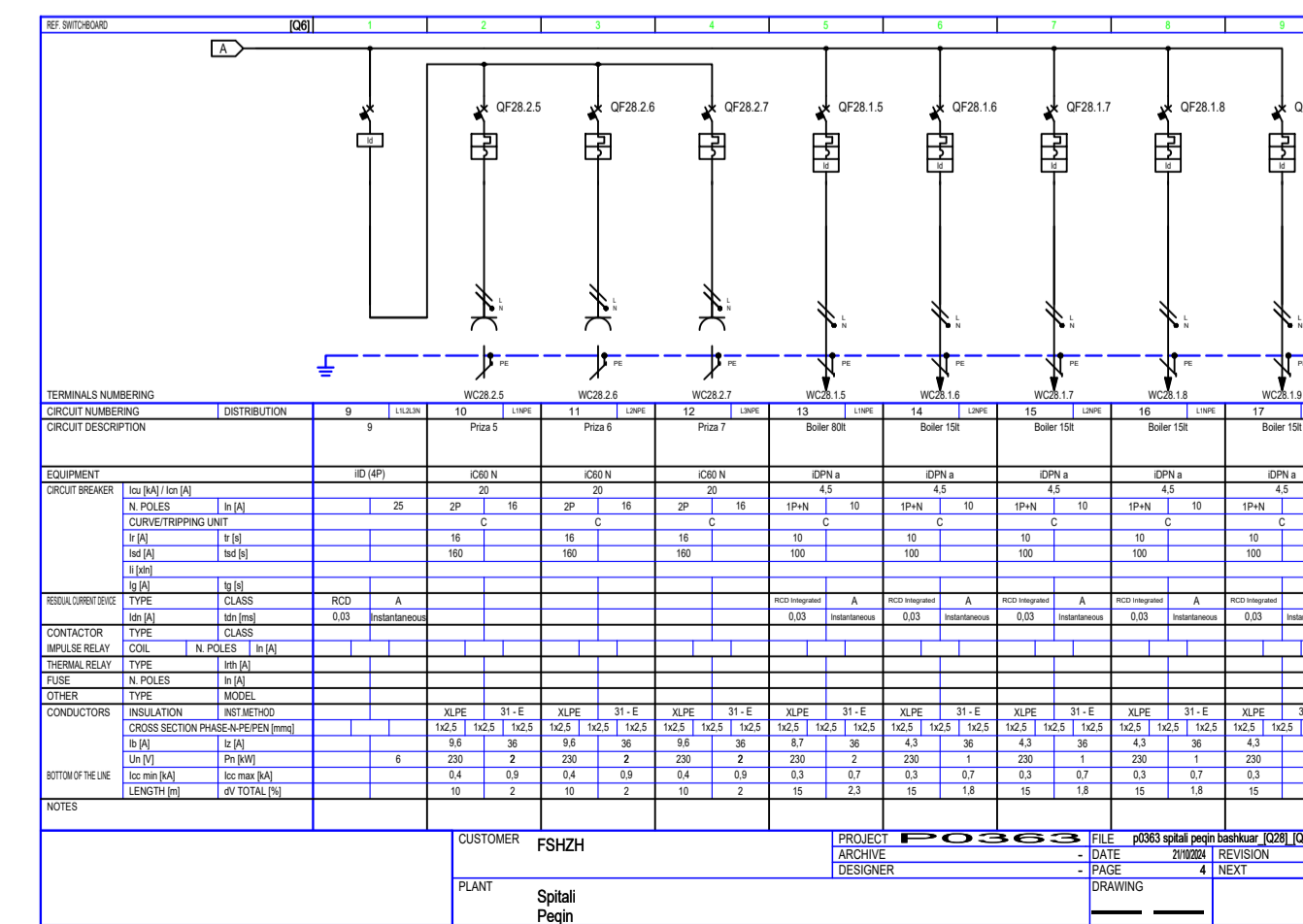
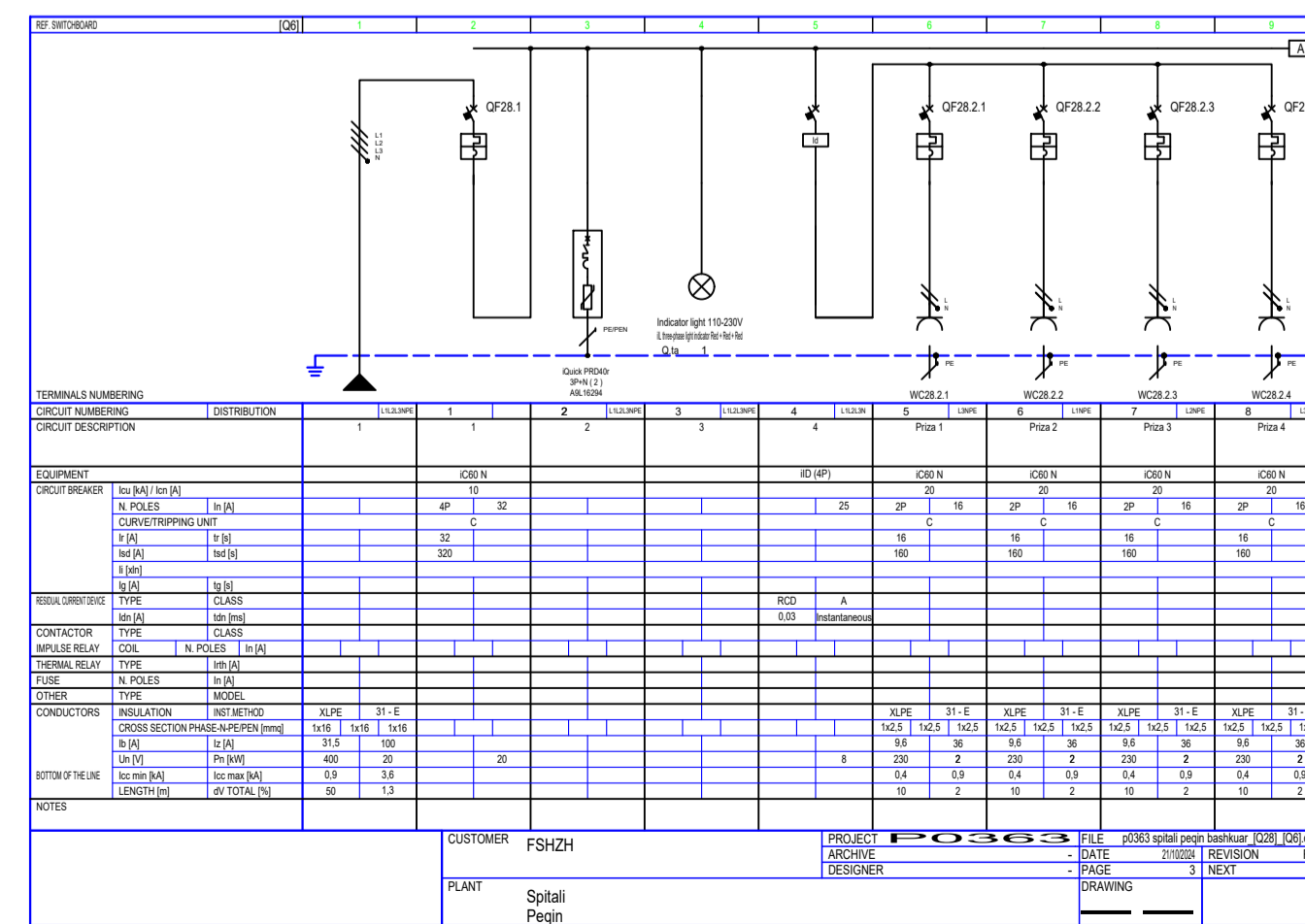
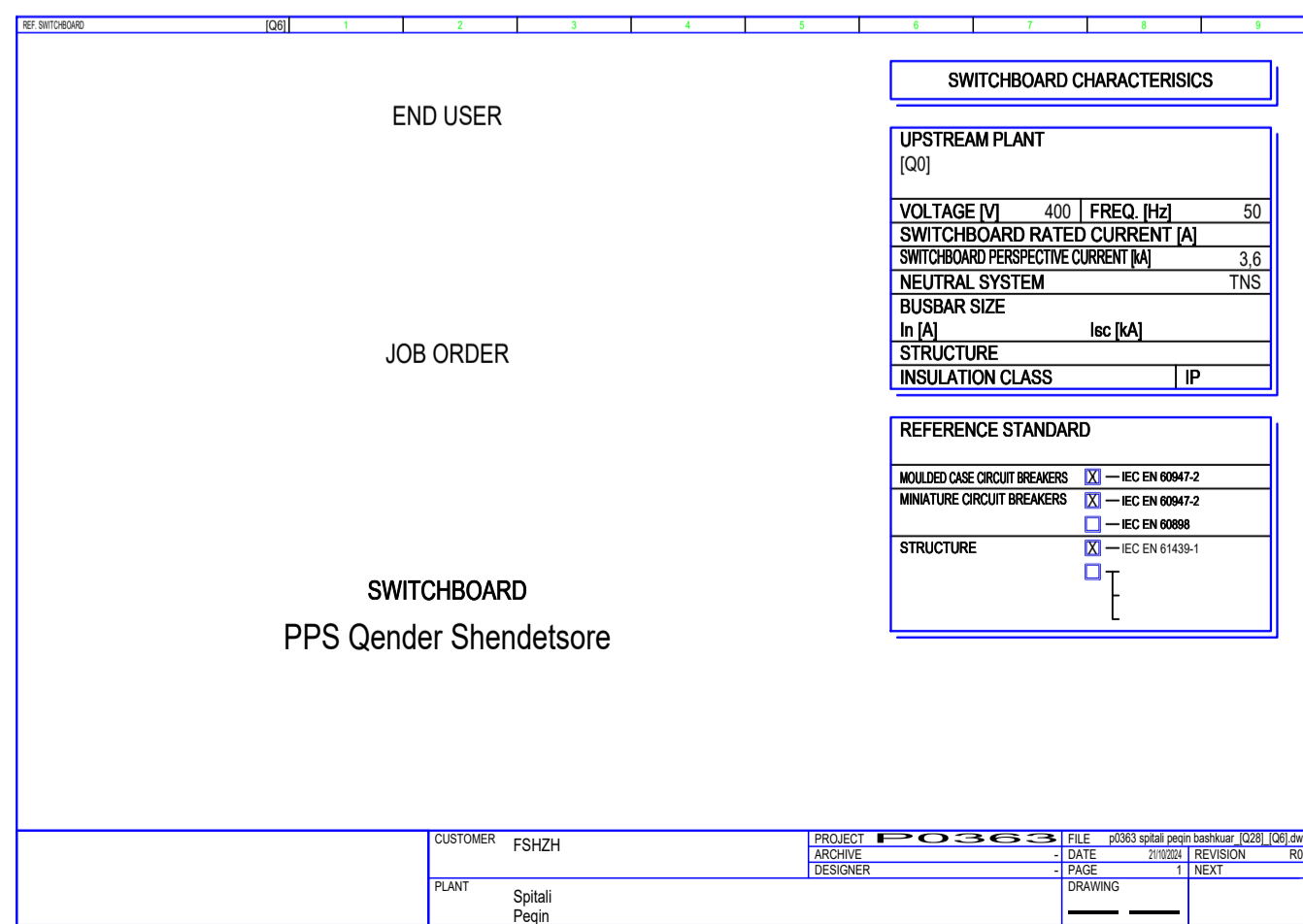
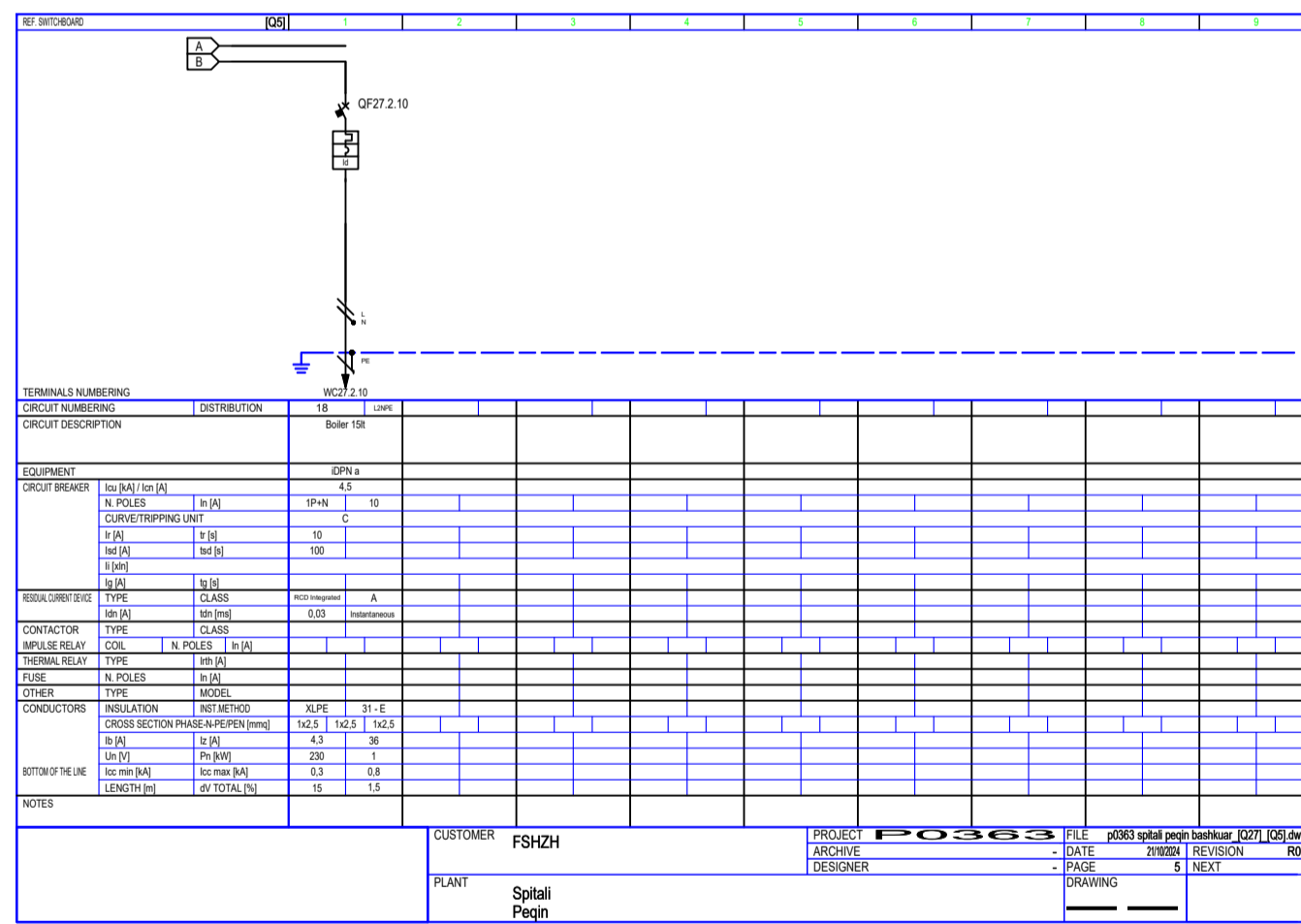
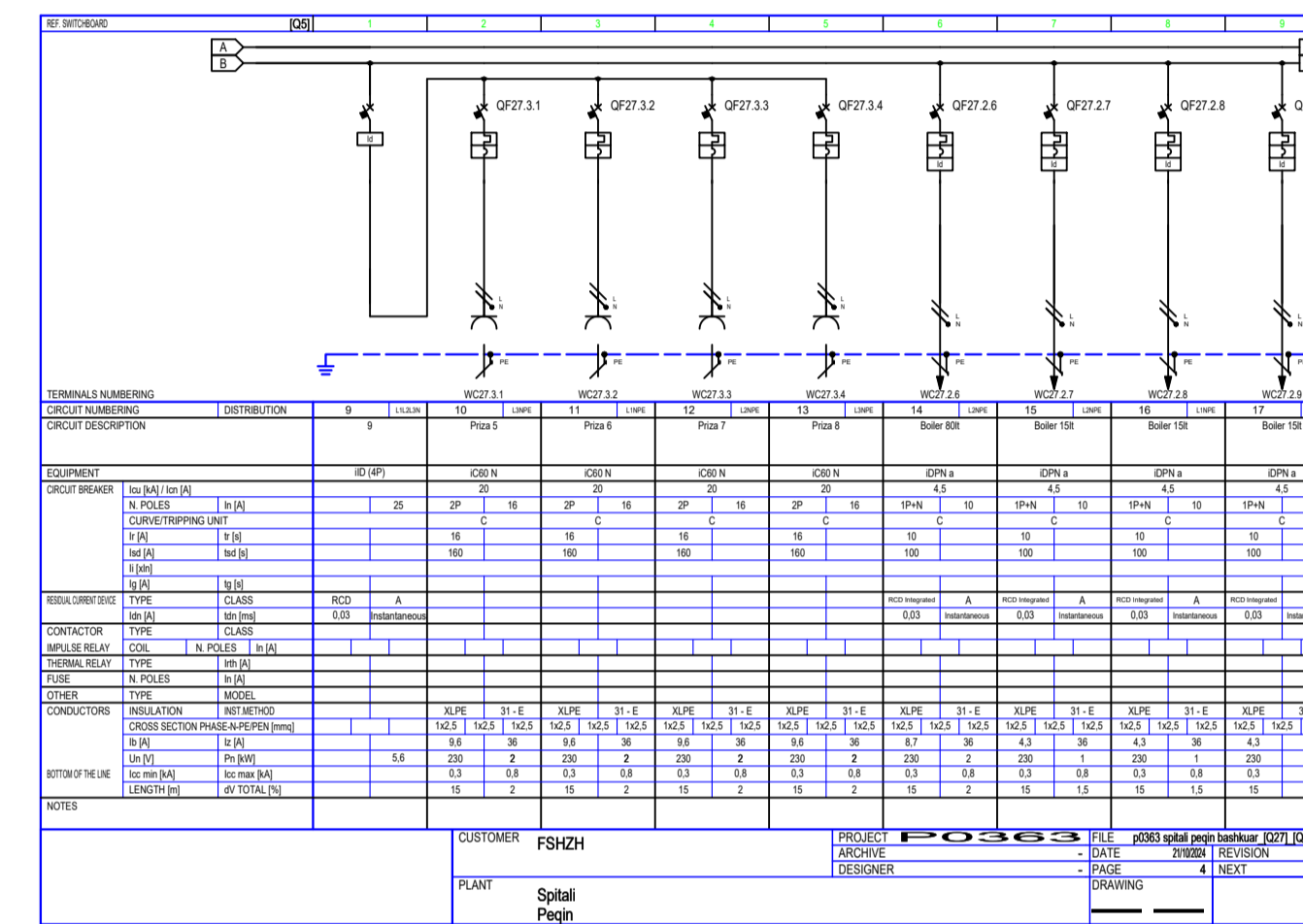
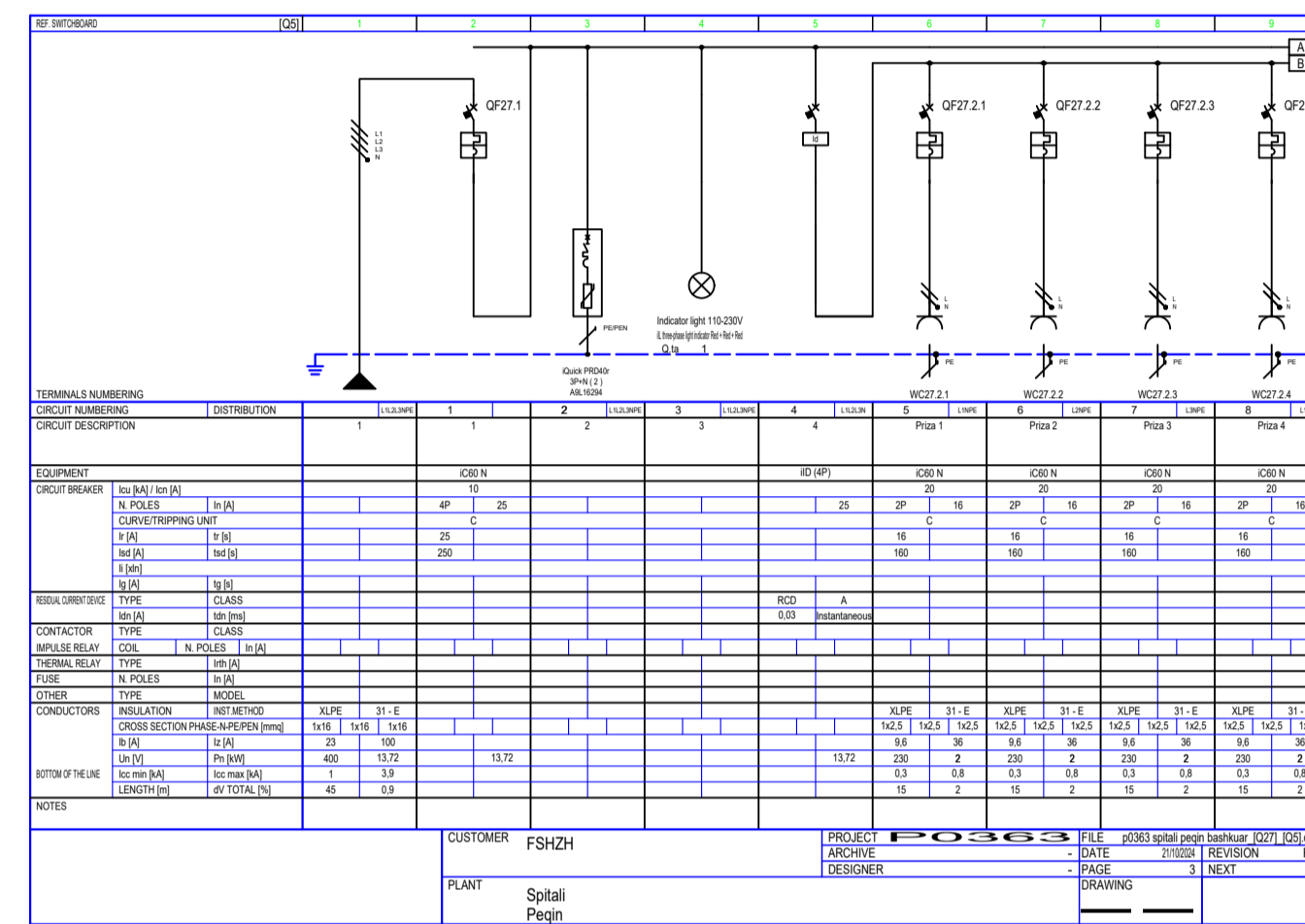
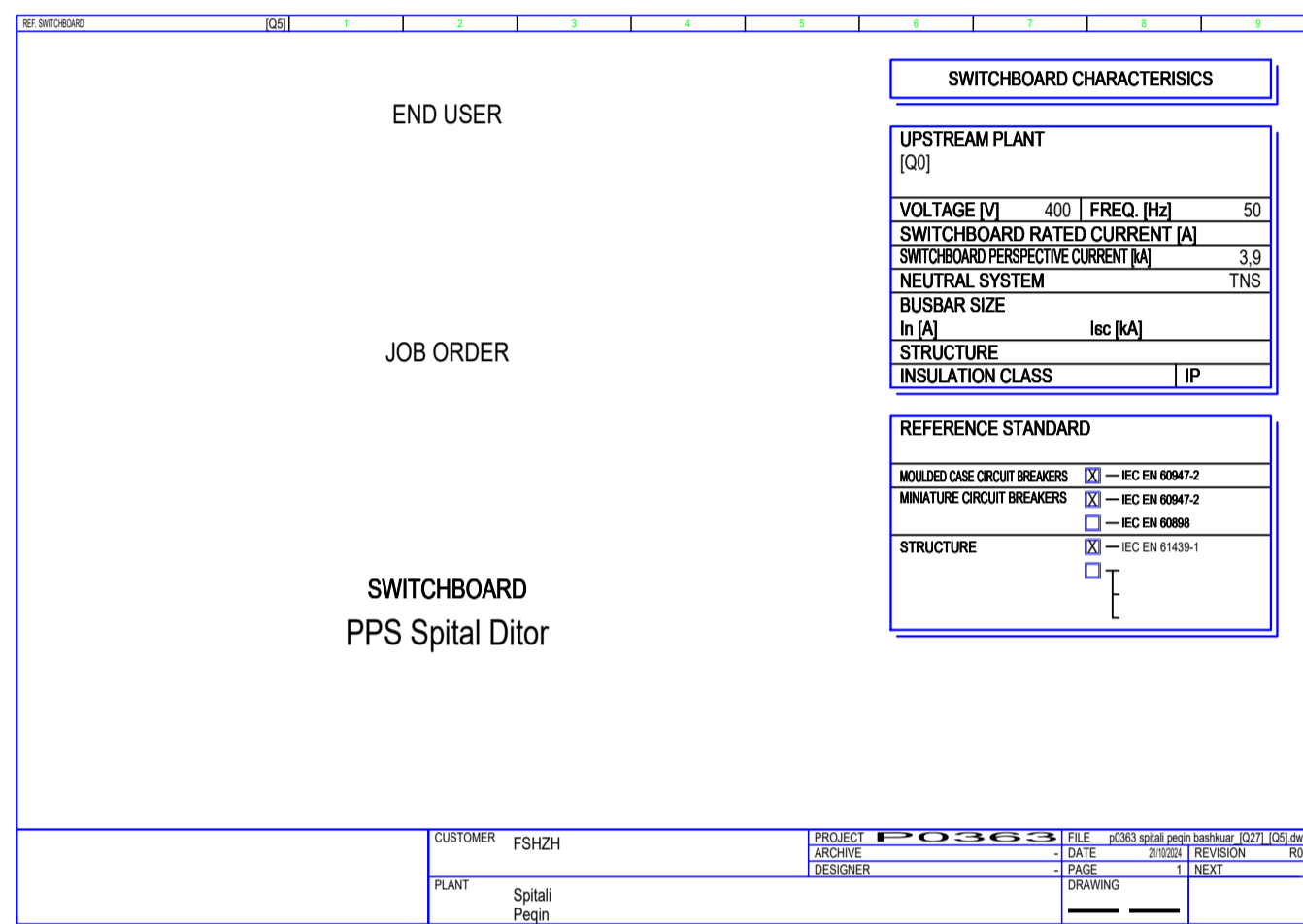
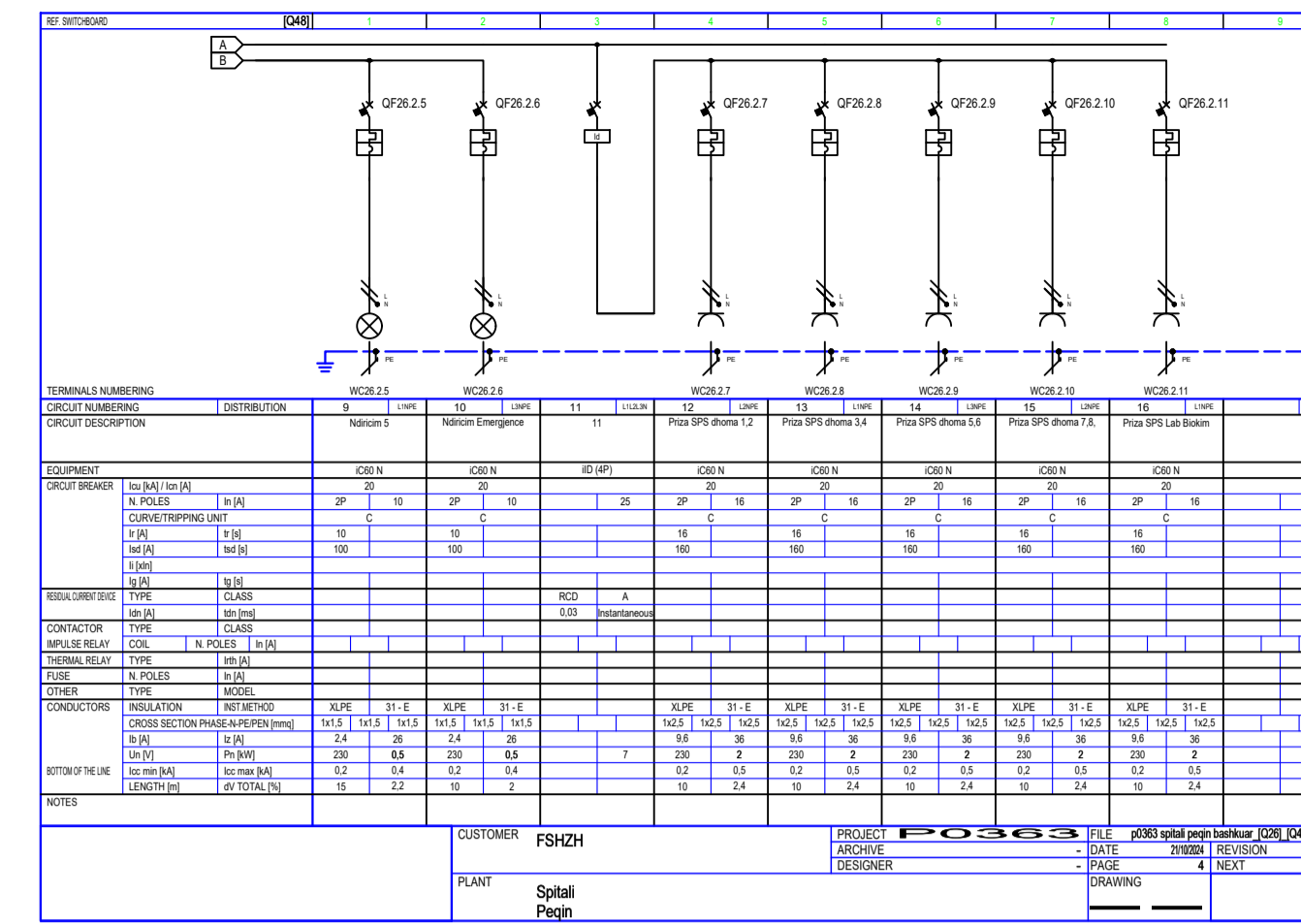
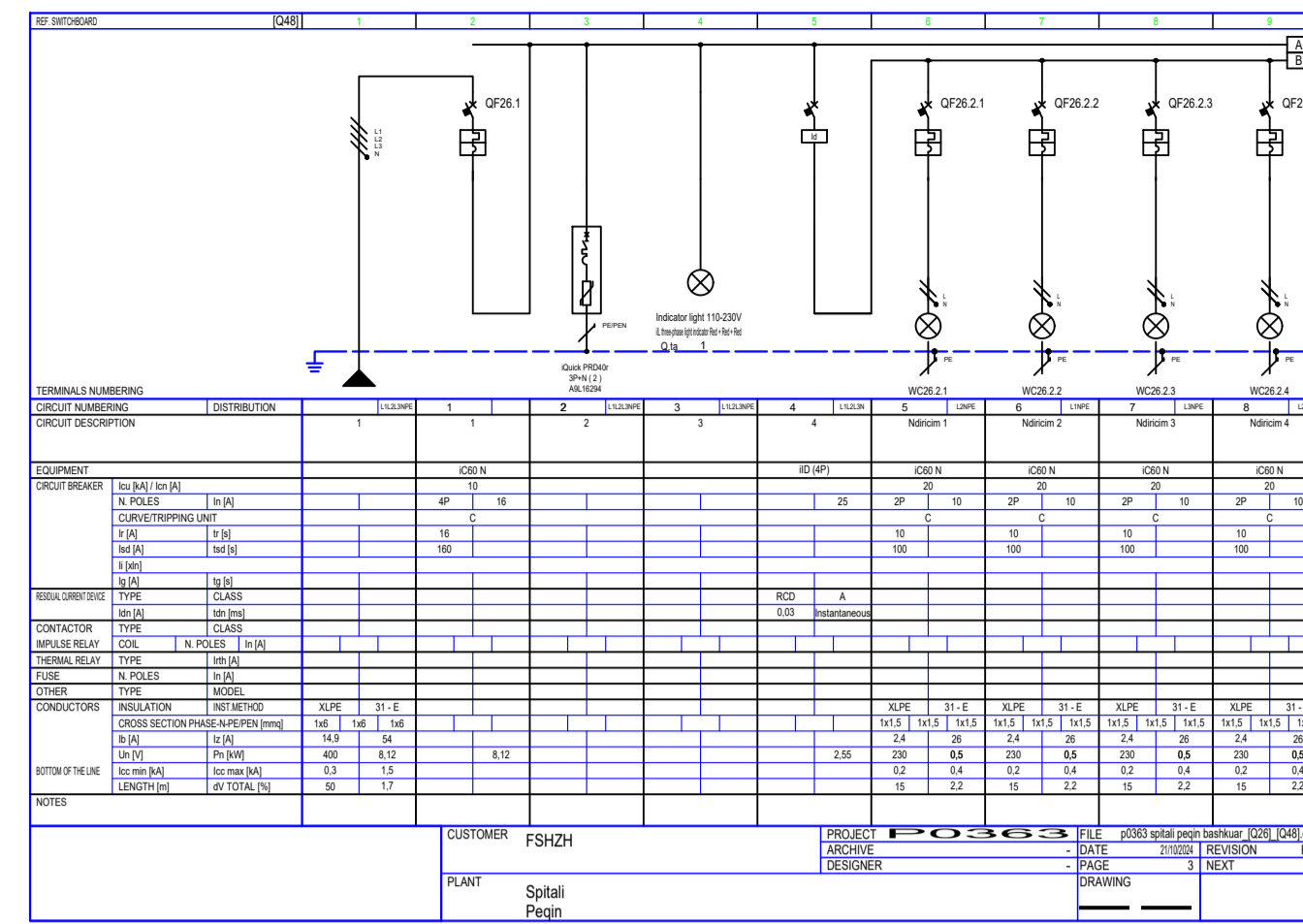
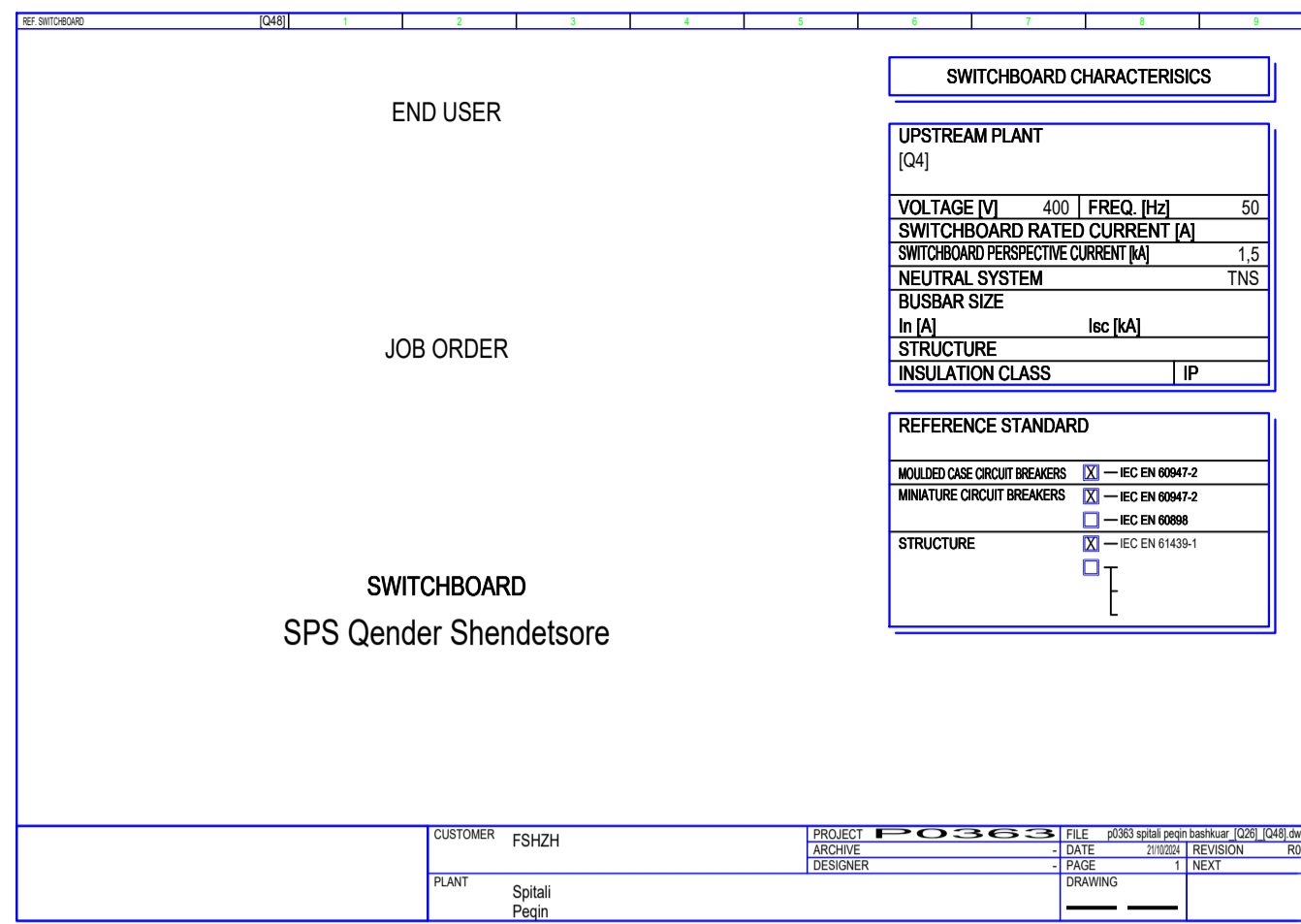

00	Tetor 2024	Projekt Leje		
RISH. NR.	DATA	QELIMI I DOREZIMIT	SHENIM / PERSHKRIM	
INVESTITORI				
KONSULENTI INXHINIERIK				
Nr. Licenses: N.5221/16				
Pergatit:	Arkitekt	Emri	Nr. Licenses	Firma
	Ing. Strukturist	Edmond MANAHASA	A.0903/2	
	Ing. Strukturist	Anila SPAHIU	K.1068/4	
	Ing. Strukturist	Alda VOKA	K.1340/2	
	Ing. Hidroteknik	Artjola ZOTAJ	K.3443	
	Ing. Hidroteknik	Silvia GJONAJ		
	Ing. Hidroteknik	Anzheta BICI	K.3452	
	Ing. Elektrik	Enis HAVERIKU	E.1450	
	Ing. Elektrik	Ilber PUCI		
	Ing. Mekanik	Marsel PYLLA	M.1288/1	
	Ing. Mekanik	Besnik KARAJ	M.0256/2	
Kontrolit:	Koordinator Projekti	Abdurrahman SPAHIU	K.1571/5	
	Ing. Strukturist	Taulant KARRIQI	K.1547/6	
	Ing. Elektrik	Emira BERISHA	E.0550/4	
Mirait:	Drejtes Projekt	Oset HAXHIU	K.1619/5	
TITULLI I PROJEKTIT				
<b>INVESTIME PILOT PËR TRANSFORMIMIN E INFRASTRUKTURËS SË SHËRBIMEVE DHE RRTJES SË STANDARDIT TË JETËS NË KOMUNITET</b>				
<b>Objekti: Ndërrhyrje për rikonstrukcionin e spitalit të Peqinit dhe ndryshim i pjesshëm i funksionit të tij</b>				
EMRI I DOKUMENTIT				
<b>SKEMAT ELEKTRIKE TË FURNIZIMIT ME ENERGIJË ELEKTRIKE DHE MBOJTJES SË PAJISJVE ELEKTRIKE / SINGLE LINE DIAGRAMS OF ELECTRICAL ENERGY SUPPLY AND PROTECTION OF ELECTRICAL EQUIPMENT</b>				
FAZA E PROJEKTIT	Nr. i Dokumentit	Shkalla	Rishikimi	Përmasa e fletës
PROJEKT LEJE	E-02	-	00	A1 (841x594mm)
				10/10