

RAPORT TEKNIK

PROJEKTI KONSTRUKTIV

RAPORT TEKNIK

**PËR LLOGARITJEN STRUKTURE TË OBJEKTIT:
HARTIM I PROJEKT PREVENTIVIT PËR “NDËRTIM I
GODINËS SË RE TË BACK-UP**

**PËR QENDRËN KOMBËTARE TË URGJENCËS
MJEKËSORE”**

NË AMBIENTET E SPITALIT RAJONAL VLORË

INXHINIER KONSTRUKTOR:

Dr. DIANA LLUKA

1. Hyrje

Objekti nga vleresimi struktural eshte nje godine me strukture betonarme me destinacion perdorimi per godinen e Back_Up per Qendren Kombetare te Urgjences Mjekesore, Vlore.

Referuar perdorimit te ndertesave dhe rendesise se saj strukturalisht godina do te klasifikohet ne bllokun e ndertesave spitalore. Ky klasifikim ndikon ne perzgjedhjen e parametrave llogarites.

Raporti teknik per llogaritjen konstruktive paraqet kushtet teknike te projektimit mbi te cilat eshte bazuar llogaritja me referencat perkatese, perzgjedhjen e parametrave llogarites referuar raporteve teknike te studimeve inxhinierike mbeshtetese, interpretimin e rezultateve dhe paraqitjen e perzgjedhjes perfundimtare te elementeve konstruktive per projekt zbatim.

Raporti teknik duhet te lexohet se bashku me vizatimet teknike te cilat jane pjese e paraqitjes perfundimtare te projekt zbatimit te objektit.

Raporti teknik i analizes strukturale mbeshtetet ne parametrat e raporteve teknike dhe projekteve te zbatimit te meposhtme:

- Projekti arkitektonik.
- Projekti mekanik.
- Projekti elektrik.
- Projekti i ngrohjes dhe ventilimit.
- Projekti i MKZ.
- Raporti i studimit gjeologjik.
- Raporti i studimit sizmologjik.
- Parametrat ambjentale te zones ku do te ndertohej objekti.

2. Kushtet teknike dhe normativat

Llogaritja dhe projektimi i strukturor bazohet ne kushtet teknike te projektimit sipas normativave evropiane te projektimit.

Projektimi sipas normativave Evropiane eshte vleresuar i domosdoshem pasi kushtet teknike te projektimit te strukturave sipas normativave shqiptare nuk jane rinovuar dhe plotesuar prej nje periudhe shume te gjate kohore dhe i perbahet kerkesave te VKM_ve te dala pas termetit te 26.11.2019 gjate dhe pas procesit te rindertimit.

Kushtet teknike te projektimit sipas standartit shqiptar do te perdoren vetem per reference ne lidhje me vlerat lokale si p.sh. parametrat per llogaritjen sizmike, era, debores, kushtet ambjentale etj.

Reference per llogaritjen konstruktive jane:

- Eurocode 0, ENV 1991-1:1994
- Eurocode 1, ENV 1991-2-1:1995
- Eurocode 2, EN 1992-1-1:2004(E)
- Eurocode 7, EN 1997-1
- Eurocode 8, EN 1998-1 (2003)

3. Projektimi i strukturave

3.1. Kushtet gjeoteknike

Sheshi i ndertimit klasifikohet nga studimi gjeologjik si truall i pershtatshem per ndertim. Themelet jane parashikuar te jene tip pllake +themele te vecuar tip plinta te lidhur me trare te vazhduar themeli per shperndarjen sa me uniforme te ngarkeses dhe te perforcuara me nenshtrese cakellii.

Karakteristikat e shtresave jane paraqitur ne raportin e studimit gjeologjik.

Referuar raportit gjeologjik dhe rekomandimeve, nivelit te larte te ujrave nentokesore shtresa mbi te cilen mbeshteten themelet eshte shtresa 3.

3.2. Sistemi struktural

Struktura eshte llogaritur si skeme 3D me programin kompjuterik Tower te licensuar. Licensa e perdorimit siguron saktesine e llogaritjeve dhe perdorimin e nivelit te fundit te teknologjise llogaritese kompjuterike, e licensuar ne vendet e Bashkimit Evropian.

Themelet jane realizuar ne formen e themeleve te vecuar tip plint.

Strukturat konstruktive vertikale mbajtese realizohen nga kolonat prej betoni te armuar te kombinuara me mure betonarme strukturale te kafazeve te shkalleve dhe ashensoreve dhe mure betonarme perimetrare ne katet nentoke.

Kolonat jane permasuar referuar vizatimeve teknike te paraqitura.

Muret e diafragmave vertikale jane me gjeresi 30cm.

Struktura konstruktive horizontale mbajtese realizohet nga soletat dhe traret.

Traret jane me permasa te prerjes terthore te paraqitur ne vizatimet teknike.

Soletat jane monolite prej betoni te armuar.

Shkalla, si element konstruktiv, është realizuar betonarme monolite, duke siguruar një lidhje midis kateve jo vetëm funksionale por edhe strukturale.

Planet strukturave mbajtëse përcaktohen në permasat gjeometrike të elementeve strukturale horizontale dhe vertikale mbajtëse dhe shërbejnë si plan të kallepeve për çdo kat të objektit.

3.3. Modelimi strukturor

Skemat llogaritëse të strukturave janë tre dimensionale (3D) gjë që lejon llogaritjen hapësinore të strukturës dhe marrjen në konsideratë të të gjithë faktorëve që realisht veprojnë në to. Nëpërmjet llogaritjes merret ndikimi i të gjithë ngarkesave vertikale dhe horizontale që aktualisht veprojnë në strukturat e ndërtimit, ku mund të përmendim ndikimin e forcave horizontale të ertës, forcave të ertetit, ndryshimit të temperaturës, çëdimit (uljet) e themeleve, ndikimin e forcave vertikale prej ngarkesave të ndryshme (të përhershme, të përkohshme, të vecanta), etj.

Çdo element në strukture është modeluar si element linear prizmatik.

a) Shtangësia e elementeve strukturale në perkulje dhe prerje është marrë në llogaritje sa 50% e shtangësise së elementit të betonit të pa plasaritur. Shtangësia elastike e elementeve në përdhrehje është sa 10% e shtangësise së elementit pa të plasura.

b) Elementet vertikale kanë permasa të prerjes tërthore me të mëdha në vlera së permasat e prerjes tërthore të traveve në këte mënyrë lidhja tra-kolone konsiderohet rigjide.

c) Gjërësia e pllakes në elementet në formë T është marrë në llogaritje sipas EC 2 sipas drejtimeve X dhe Y respektivisht dhe është minimalisht sa 20% e hapësirës drite të traut.

d) Soletat janë konsideruar diafragma rigjide.

e) Pllaka e themelit është modeluar me sustat e Winkler duke vlerësuar truallin sipas parametrave të studimit gjeologjik.

f) Masat janë llogaritur për ngarkesat gravitacionale me formulën $G + \Psi_E Q$, ku $\Psi_E = \phi \psi_2$, dhe ψ_2 përcaktohet në varesi të kategorisë së ngarkesave të përkohshme sipas tabelës A1.1. EC0 për EN 1990:2001

Table A1.1 - Recommended values of ψ factors for buildings

Action	ψ_0	ψ_1	ψ_2
Imposed loads in buildings, category (see EN 1991-1-1)			
Category A : domestic, residential areas	0,7	0,5	0,3
Category B : office areas	0,7	0,5	0,3
Category C : congregation areas	0,7	0,7	0,6
Category D : shopping areas	0,7	0,7	0,6
Category E : storage areas	1,0	0,9	0,8
Category F : traffic area, vehicle weight $\leq 30\text{kN}$	0,7	0,7	0,6
Category G : traffic area, $30\text{kN} < \text{vehicle weight} \leq 160\text{kN}$	0,7	0,5	0,3
Category H : roofs	0	0	0
Snow loads on buildings (see EN 1991-1-3)*			
Finland, Iceland, Norway, Sweden	0,70	0,50	0,20
Remainder of CEN Member States, for sites located at altitude $H > 1000$ m a.s.l.	0,70	0,50	0,20
Remainder of CEN Member States, for sites located at altitude $H \leq 1000$ m a.s.l.	0,50	0,20	0
Wind loads on buildings (see EN 1991-1-4)	0,6	0,2	0
Temperature (non-fire) in buildings (see EN 1991-1-5)	0,6	0,5	0
NOTE The ψ values may be set by the National annex. * For countries not mentioned below, see relevant local conditions.			

Llogaritja e struktures ndahet ne keto nenfaza:

- 3.3.1 Percaktimi i gjeometrise se struktures.
- 3.3.2 Percaktimi i parametrave llogarites te betonit dhe celikut.
- 3.3.3 Percaktimi i ngarkesave.
- 3.3.4 Modelimi i truallit.
- 3.3.5 Percaktimi i koeficienteve sizmike.
- 3.3.6 Percaktimi i koeficienteve te kombinimit te ngarkesave.
- 3.3.7 Llogaritja e struktures eshte realizuar referuar :
 - a) Llogaritjes sipas gjendjes se pare kufitare, (llogaritja ne aftesi mbajttese) (ULS).
 - b) Llogaritjes sipas gjendjes se dyte kufitare, (llogaritja ne fazen e shfrytezimit) (SLS), percaktimi i deformacioneve dhe madhesis se hapjes te te plasurave).

3.3.1. Percaktimi i gjeometrise se struktures.

Skema strukturele diktohet nga permasat planimetricke dhe forma ne plan e objektit. Gjeometria e strukturave percaktohet ne funksion te zgjidhjes arkitektonike dhe konstruktive. Skema strukturele ploteson kerkesat referuar kushteve teknike te projektimit dhe interpretimit te rezultateve te dala pas llogaritjes.

Pozicionimi i elementeve vertikale mbajtes, perzgjedhja e tyre kombinimi i elementeve tip kolone me mure betonarme perimetrare te bodrumit siguron shtangesine e objektit ne lidhje me sjelljen dhe reagimin e struktures nga veprimi i kombinimit te ngarkesave.

Verehet se sipas skemave te zgjedhura struktura klasifikohet si dual system sipas EC8 5.12. (1) prEN 1998-1 (2003)per klasifikimin struktural. Kafazet e ashensoreve dhe kafazet e shkalleve jane realizuar me mure betonarme. Kjo kerkese rrjedh nga projekti arkitektonik dhe kerkesat e skemes strukturale.

3.3.2. Percaktimi i parametrave llogarites te betonit dhe celikut.

Struktura sipas klasifikimit struktural EC0_ENV 1991-1:1994 (2001), Tab.2.1 dhe EC2_EN 1992-1-1:2004(E) sipas 4.4.1.2.(5) per jetegjatesi projektuese 50 vjet jane te klases S4.

Table 2.1 - Indicative design working life

Design working life category	Indicative design working life (years)	Examples
1	10	Temporary structures ⁽¹⁾
2	10 to 25	Replaceable structural parts, e.g. gantry girders, bearings
3	15 to 30	Agricultural and similar structures
4	50	Building structures and other common structures
5	100	Monumental building structures, bridges, and other civil engineering structures

(1) Structures or parts of structures that can be dismantled with a view to being re-used should not be considered as temporary.

Klasa e ekspozicionit e perzgjedhur i referohet Tab. 4.1, EN 1992-1-1:2004(E) sipas EC2.

Klasa e ekspozicionit te struktures ne terresi eshte perzgjedhur klasa XC2/XS1/XA1.

Klasa e betonit e perzgjedhur per themelin i referohet Tab. 4.3N, dhe tab. 4.E.1N sipas EC2_EN 1992-1-1:2004(E)

Note: Values of indicative strength classes for use in a Country may be found in its National Annex. The recommended values are given in Table E.1N.

Table E.1N: Indicative strength classes

Exposure Classes according to Table 4.1	
Corrosion	
	Carbonation-induced corrosion
	Chloride-induced corrosion
	Chloride-induced corrosion from sea-water
	XC1 XC2 XC3 XC4 XD1 XD2 XD3 XS1 XS2 XS3
Indicative Strength Class	C20/25 C25/30 C30/37 C30/37 C35/45 C30/37 C35/45
Damage to Concrete	
	No risk Freeze/Thaw Attack Chemical Attack
	XD XF1 XF2 XF3 XA1 XA2 XA3
Indicative Strength Class	C12/15 C30/37 C25/30 C30/37 C30/37 C35/45

Perfundimisht betoni eshte perzgjedhur i klases C30/37 per gjithe strukturen dhe armatura e celikut eshte S500 C minimalisht.

Klasa e betonit te mbistrukture eshte perzgjedhur C30/37 per gjithe objektin me karakteristika referuar Tab. 4.E.1N sipas EC2_EN 1992-1-1:2004(E).

f_{ck} (MPa)	Strength classes for concrete												Analytical relation / Explanation		
	12	16	20	25	30	35	40	45	50	55	60	70		80	90
$f_{ck,corr}$ (MPa)	15	20	25	30	37	45	50	55	60	67	75	85	95	105	$f_{ck,corr} = 0.30 \cdot f_{ck}^{(corr)} \leq 50/60$ $f_{ck,corr} = 2.12 \cdot \ln(1 + (f_{ck}/10))$ $> C60/80$
f_{cm} (MPa)	20	24	28	33	38	43	48	53	58	63	68	78	88	98	$f_{cm} = f_{ck} + 8$ (MPa)
f_{td} (MPa)	1.6	1.9	2.2	2.6	2.9	3.2	3.5	3.8	4.1	4.2	4.4	4.6	4.8	5.0	$f_{td} = 0.7 \cdot f_{cm}$ 5% fractile
$f_{td,0.05}$ (MPa)	1.1	1.3	1.5	1.8	2.0	2.2	2.5	2.7	2.9	3.0	3.1	3.2	3.4	3.5	$f_{td,0.05} = 1.3 \cdot f_{td}$ 95% fractile
$f_{td,0.95}$ (MPa)	2.0	2.5	2.9	3.3	3.8	4.2	4.6	4.9	5.3	5.5	5.7	6.0	6.3	6.6	$E_{cm} = 22 \cdot (f_{ck}/10)^{1.3}$ (f_{ck} in MPa)
E_{cm} (GPa)	27	29	30	31	33	34	35	36	37	38	39	41	42	44	see Figure 3.2 $\epsilon_{st} (‰) = 0.7 \cdot f_{ck}^{0.31} < 2.8$
ϵ_{st} (‰)	1.8	1.9	2.0	2.1	2.2	2.25	2.3	2.4	2.45	2.5	2.6	2.7	2.8	2.8	see Figure 3.2 for $f_{ck} \geq 50$ Mpa $\epsilon_{st} (‰) = 2.8 \cdot (f_{ck}/95)^{1/100}$
$\epsilon_{st,1}$ (‰)				3.5						3.2	3.0	2.8	2.8	2.8	see Figure 3.3 for $f_{ck} \geq 50$ Mpa $\epsilon_{st,1} (‰) = 2.0 + 0.085 \cdot (f_{ck} - 50)^{0.25}$
$\epsilon_{st,2}$ (‰)				2.0						2.2	2.3	2.4	2.5	2.6	see Figure 3.3 for $f_{ck} \geq 50$ Mpa $\epsilon_{st,2} (‰) = 2.0 + 0.085 \cdot (f_{ck} - 50)^{0.25}$
$\epsilon_{st,3}$ (‰)				3.5						3.1	2.9	2.7	2.6	2.6	see Figure 3.4 for $f_{ck} \geq 50$ Mpa $\epsilon_{st,3} (‰) = 1.75 + 0.55 \cdot [(f_{ck} - 50)/40]$
n				2.0						1.75	1.6	1.45	1.4	1.4	for $f_{ck} \geq 50$ Mpa $n = 1.4 + 23.4 \cdot (90 - f_{ck})/100^2$
$\epsilon_{st,4}$ (‰)				1.75						1.8	1.9	2.0	2.2	2.3	see Figure 3.4 for $f_{ck} \geq 50$ Mpa $\epsilon_{st,4} (‰) = 1.75 + 0.55 \cdot [(f_{ck} - 50)/40]$
$\epsilon_{st,5}$ (‰)				3.5						3.1	2.9	2.7	2.6	2.6	see Figure 3.4 for $f_{ck} \geq 50$ Mpa $\epsilon_{st,5} (‰) = 2.0 + 0.085 \cdot (f_{ck} - 50)^{0.25}$

Table 3.1 Strength and deformation characteristics for concrete

Tab.3.1 Karakteristikat e betonit sipas EC2_EN 1992-1-1:2004(E)

Armatura e celikut eshte S500C sipas tab: C.1 EC2.

Kombinimi i celikut dhe betonit ploteson te gjitha kerkesat per materialet qe perbejne elementet konstruktive mbajtese sipas rekomandimeve te EC2 (Referuar Tab. 4.1, En 1992-1-1:2004(E))

Ne baze te klasifikimit te mbrojtjes kunder zjarrit referuar kerkesave te EC2 dimensionimi i shtresave mbrojtese te elementeve konstruktive eshte realizuar per klasen e mbrojtjes kunder zjarrit **REI 90**.

Diagramat e idealizuara te sjelljes se materialit sipas EC2 per celikun dhe betonin jane:



Diagrama e idealizuar per çeliquet e zakonshem



Diagrama e idealizuar per betonet e zakonshem

Koeficientet parciale te sigurise per materialet per llogaritjen ne gjendjen kufitare te fundme i referohen Tab.2.1N, EC2_EN 1992-1-1:2004(E)

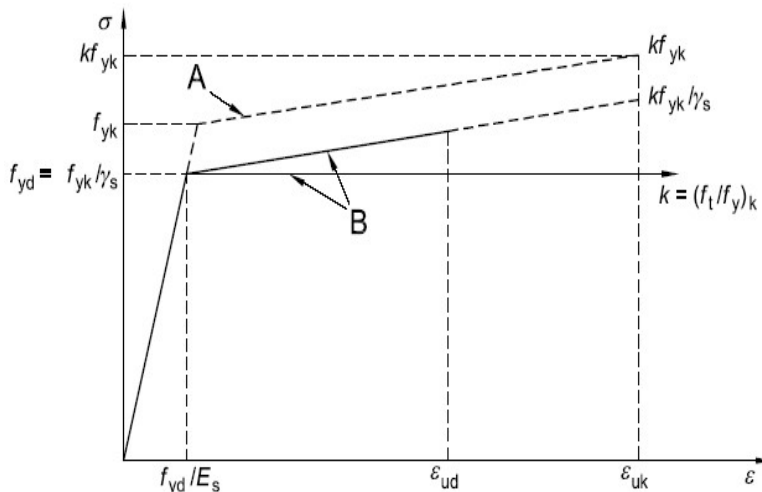
Table 2.1N: Partial factors for materials for ultimate limit states

Design situations	γ_c for concrete	γ_s for reinforcing steel	γ_s for prestressing steel
Persistent & Transient	1,5	1,15	1,15
Accidental	1,2	1,0	1,0

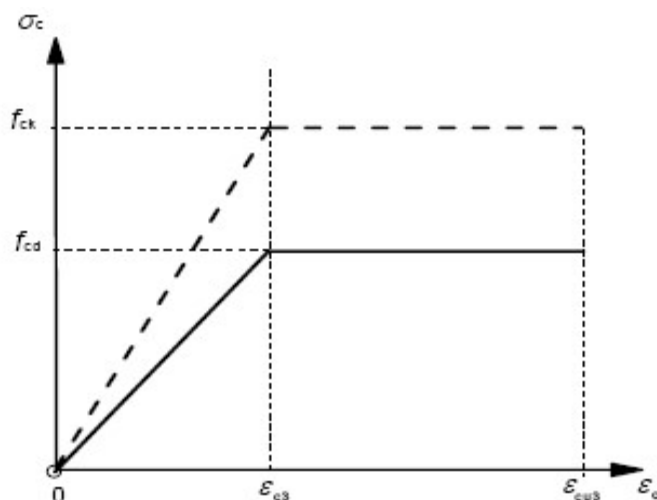
Koeficientet parciale te sigurise per materialet per llogaritjen ne gjendjen e sherbimit i referohen rekomandimeve te pikes 2.4.2.4 (2) shenimit sipas EC2_EN 1992-1-1:2004(E) ku vlerat e tyre merren ne llogaritje te barabarta me 1.0.

3.3.3. Percaktimi i ngarkesave.

Ngarkesat jane percaktuar bazuar ne klasifikimin e ngarkesave sipas Eurokodeve EC1 dhe kombinimi i tyre sipas EC0.

a) Vlerat e ngarkesave konstante jane percaktuar referuar parametrave sipas EC1.

- Betoni i armuar eshte marre ne llogaritje me peshe volumore 25kN/m³.
- Sistemimet e jashtme jane llogaritur me ngarkese 5kN/m²
- Ngarkesa e shtresave dhe e mureve ne soleta eshte 2.5 kN/m².
- Ngarkesa e dyshemese teknologjike eshte 1 kN/m².
- Ngarkesa e mureve mbi trare eshte llogaritur 11kN/ml.

b) Ngarkesat e perkohshme ne relacionin teknik jane paraqitur me vlerat e tyre referuar ngarkeses uiformisht te shperndare per 1m² siperfaqe horizontale. Ngarkesat i referohen Tab.6.1, 6.7, 6.2, 6.8. sipas EC1 prEN 1991-1-1:2001.

Ngarkesa e perkohshme (live load) eshte marre ne llogaritje:

1. Ambjentet e sherbimit, kategoria C:

- pergjithesisht $q_k=3\text{kN/m}^2$, $Q_k=4\text{kN}$
- shkallet $q_k=4\text{kN/m}^2$, $Q_k=4\text{kN}$
- ballkonet $q_k=4\text{kN/m}^2$, $Q_k=3\text{kN}$
- parapetet $q_k=0.5\text{ kN/ml}$ (Tab. 6.12).

2. Ambjentet mekanike te sherbimit **kategoria E** me $q_k=6\text{kN/m}^2$

3.3.4 Modelimi i truallit.

Themeli eshte realizuar i ndikuar nga:

- a) Kushtet gjeologjike inxhinierike dhe prezenca e ujrave nentokesore.
- b) Siperfaqja e tabanit te themelit.
- c) Vleresimi i sforcimeve ne taban nga llogaritja strukturale.
- d) Projekti arkitektonik i shfrytezimit te objektit me katet nentoke.
- e) Shperndarja sa me uniforme e sforcimeve ne taban per te zvogeluar ndikimin ne objektet fqinje ekzistuese.

Parametrat e modelimit te truallit jane paraqitur ne relacionin teknik duke percaktuar vleren e koeficientit suste sipas modelit Winkler.

Parametrat e modelimit te truallit jane llogaritur referuar studimit gjeologjiko-inxhinierik duke shfrytezuar parametrat e shtreses mbeshetese te tabanit dhe shtresave te tjera qe hyjne ne zonen aktive te truallit dhe formes se themelit.

3.3.5. Percaktimi i koeficienteve sizmike.

a) Referuar studimit sizmologjik nxitimi maksimal (PGA) eshte $a_g=0.317g$ per nxitimin horizontal, bazuar raportin e studimit sizmologjik per sheshin brenda qytetit te Vlores sipas kerkesave te EC8 prEN 1998-1 (2003) 4.2.5 pika 5(P) $\gamma_I=1.4$.

Ky klasifikim eshte konsideruar ne grupin e godinave te spitaleve, kategoria IV.

Per nxitimin horizontal te projektimit nga raporti i studimit sizmologjik trualli eshte i tipit C, (reference raporti sizmologjik), perzgjedhim shkallen e duktilitetit mesatar, DCM.

b) Ne llogaritje perdoret Spektri elastik i tipit 1 sipas EC8 prEN 1998-1 (2003).

Per te percaktuar spektrin elastik horizontal perdoren shprehjet e meposhtme :

$$0 \leq T \leq T_B \quad S_e(T) = a_g \cdot S \cdot [1 + T \cdot (\eta \cdot 2.5 - 1) / T_B]$$

$$T_B \leq T \leq T_C \quad S_e(T) = a_g \cdot S \cdot \eta \cdot 2.5$$

$$T_C \leq T \leq T_D \quad S_e(T) = a_g \cdot S \cdot \eta \cdot 2.5 \cdot [T_C / T]$$

$$T_D \leq T \leq 4s \quad S_e(T) = a_g \cdot S \cdot \eta \cdot 2.5 \cdot [T_C \cdot T_D / T^2]$$

Per shuarje $\eta=5\%$.

Referuar raportit gjeologjik, trualli mund te klasifikohet si truall i kategorise C sipas EC8.

Sipas rekomandimeve te EC8 prEN1998_1_dec2003 tab.3.2 parametrat llogarites per tipin 1 te spektrit elastik jane:

- Trualli ne llogaritje eshte i tipit C, (PGA) $a_g=0.317g$ tipi 1 i spektrit elastik te EC 8, $\eta = 1.0$ per shuarje 5% sipas raportit teknik te studimit sizmologjik.
- Projektimi sizmik sipas Eurokodit 8 eshte per DC M (Medium).

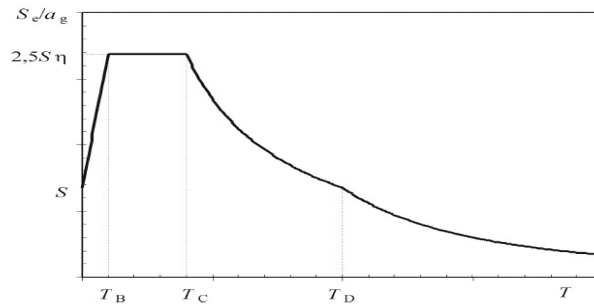

Forma e spektrit elastik te reagimit te struktures, sipas EC 8

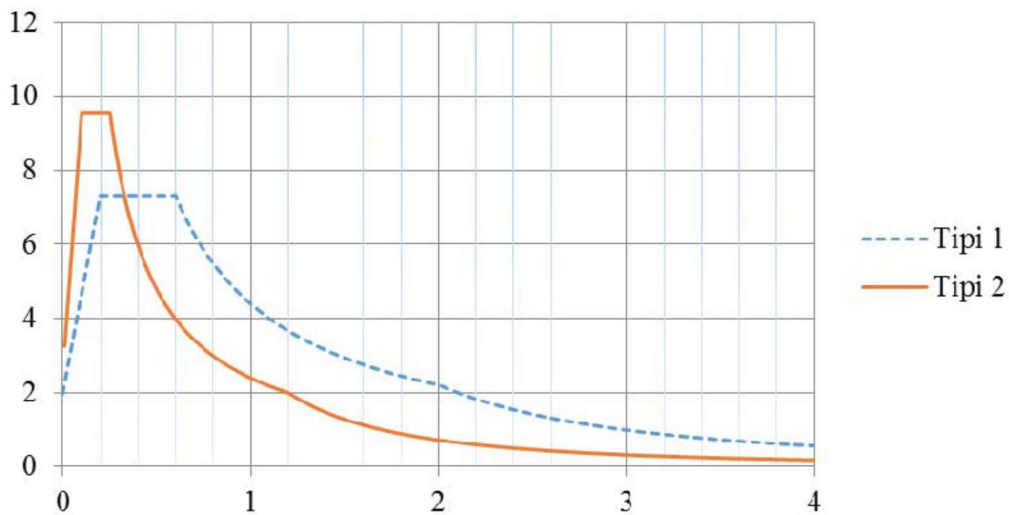

Spektri i reagimit elastik $a_g=0.26g$, tipi i truallit C

Tipi i truallit	S	$T_B(s)$	$T_C(s)$	$T_D(s)$
A	1,0	0,15	0,4	2,0
B	1,2	0,15	0,5	2,0
C	1,15	0,20	0,6	2,0
D	1,35	0,20	0,8	2,0
E	1,4	0,15	0,5	2,0

Vlerat e paramtrave qe pershkruajne spektrin e reagimit elastik te tipit 1

Spektri i projektimit sipas EC 8 per komponentet horizontale, llogaritet me shprehjet:

$$0 \leq T \leq T_B \quad S_d(T) = a_g \cdot S \cdot [2/3 + (T/T_B) \cdot (2.5/q - 2/3)]$$

$$T_B \leq T \leq T_C \quad S_d(T) = a_g \cdot S \cdot 2.5/q$$

$T_C \leq T \leq T_D$	$S_d(T) = a_g \cdot S \cdot (2.5/q) \cdot [T_C/T]$ $S_d(T) \geq \beta \cdot a_g$
$T_D \leq T$	$S_d(T) = a_g \cdot S \cdot (2.5/q) \cdot [T_C \cdot T_D/T^2]$ $S_d(T) \geq \beta \cdot a_g$

$\beta = 0.2$ sipas vleres se rekomanduar nga EC8 prEN 1998-1 (2003)

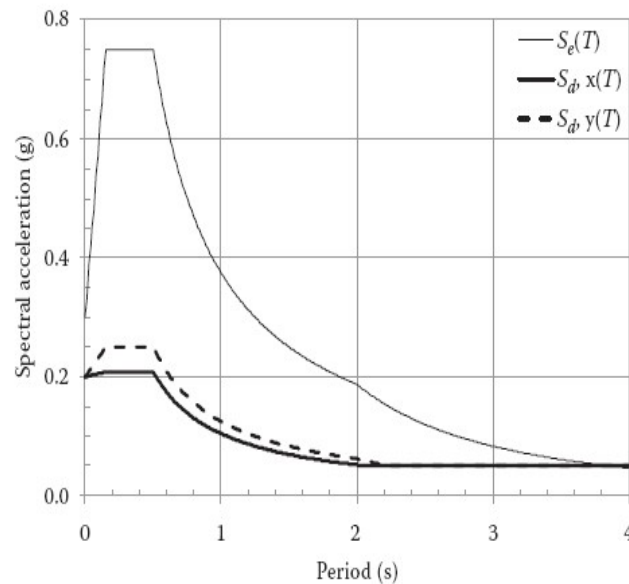

Spektri i projektimit ne X dhe Y me shuarje 5%

Sipas tab.4.3 prEN1998_1_dec2003, objekti klasifikohet ne klasen e rendesise IV, koeficienti i rendesise se objektit rekomandohet ne vleren $\gamma I = 1.4$ sipas prEN 1998-1 (2003) 4.2.5 pika 5(P).

Koeficienti i sjelljes se struktures

Koeficienti i sjelljes se struktures sipas 5.2.2.2 EC8 prEN 1998-1 (2003) bazohet ne klasifikimin e tipit te struktures.

Eshte realizuar llogaritja statike me metoden e forcave anesore sipas EC8 per te percaktuar raportet ne % te forces prerese qe perballon muri ne baze ne raport me totalin sipas dy drejtimeve ortogonale.

$V_{wall, X} / V_{b, X}$ sipas X dhe $V_{wall, Y} / V_{b, Y}$ sipas Y.

Strukturat e seksioneve ne teresi klasifikohen ne dual system sipas seksionit 5.2.2.1. "Structural type" te EC8 prEN1998_1_dec2003.

Koeficienti i sjelljes se struktures eshte:

$$q = q_0 k_w \geq 1.5$$

Klasa e duktilitetit eshte DCM.

$$q_0 = 3.0 \alpha_u / \alpha_1$$

$$\alpha_u / \alpha_1 = 1.15 \text{ sipas drejtimit X}$$

$$\alpha_u / \alpha_1 = 1.15 \text{ sipas drejtimit Y}$$

Struktura nuk eshte e rregullt ne plan edhe por eshte e rregullt ne lartesi sipas EC 1998.

Referuar Fig.4.1. EC8 prEN1998_1_dec2003 kontrollohen dhe vleresohen kriteret (b) dhe (d) sipas dy drejtimeve ortogonale kryesore te planit te struktures.

Efektet perdredhes aksidentale

Efektet perdredhes aksidentale jane vleresuar sipas EC 8 ne masen $e_{ai} = 0.05L_i$ ku L_i eshte dimensionimi ne plan i objektit perpendikular me drejtimin e veprimit sizmik.

3.3.6 Percaktimi i koeficienteve te kombinimit te ngarkesave.

Llogaritja dhe projektimi i struktures eshte realizuar sipas gjendjes kufitare te fundme (ULS), ekuilibrit statik (EQU), projektimit te elementeve strukturale (STR), bashkeveprimit truall strukture dhe rezistences se truallit (GEO) dhe llogaritjen ne fazen e sherbimit (SLS). Referenca EC0 (A1.3.) (2001)

Koeficientet per kombinimin e ngarkesave i referohen Tab.A1.1 EC0 EN 1990_FinalDraft_July2001.

Rezultatet paraqiten ne formatin e llogaritjeve kompjuterike jepen ne vijim.

3.3.7 Llogaritja e struktures

Llogaritja e strukturave eshte realizuar referuar :

a) Llogaritjes sipas gjendjes se pare kufitare, (llogaritja ne aftesi mbajttese). Referenca EC0 (A1.3.) (2001).

b) Llogaritjes sipas gjendjes se dyte kufitare, (llogaritja ne fazen e shfrytezimit, percaktimi i deformacioneve dhe madhesis se hapjes te te plasurave). Referenca EC0 (A1.4.) (2001) per secilin bllok struktural.

Vlerat kufitare ne llogaritjen ne fazen e sherbimit paraqiten ne Tab.7.1.N te EC2.

Note: The value of w_{max} for use in a Country may be found in its National Annex. The recommended values for relevant exposure classes are given in Table 7.1N.

Table 7.1N Recommended values of w_{max} (mm)

Exposure Class	Reinforced members and prestressed members with unbonded tendons	Prestressed members with bonded tendons
	Quasi-permanent load combination	Frequent load combination
X0, XC1	0,4 ¹	0,2
XC2, XC3, XC4	0,3	0,2 ²
XD1, XD2, XS1, XS2, XS3		Decompression

Modelimi i struktures eshte realizuar duke plotesuar kriteret e 4.3.1. te EC8 prEN1998_1_dec2003.

ANEKS A
Llogaritja e struktures

Basic model properties

Database: backup_Vlore.twp
Analysis date: 23.10.2023

Analysis type: 3D model

- Linear theory Modal Analysis Stability
 Non-linear theory Seismic analysis Stage Construction
 Non linear analysis

Model size

Number of nodes: 8324
Number of area elements: 8151
Number of beams: 1001
Number of boundary elements: 7236
Number of primary load cases: 9
Number of load case combinations: 26

Units

Length: m [cm,mm]
Force: kN
Temperature: Celsius

Input data - Structure

Level scheme

Name	z [m]	h [m]
Kafazi i shkalleve	10.96	3.26
Tarraca	7.70	3.85
1	3.85	1.08
streha	2.77	2.77
0	0.00	2.50
Themeli	-2.50	

Table of materials

No	Material name	E[kN/m ²] Em[kN/m ²]	μ μ_m	γ [kN/m ³] αt [1/C]
1	C 30/37	3.300e+7 3.300e+7	0.20 0.20	25.00 1.000e-5
2	Steel	2.100e+8 2.100e+8	0.30 0.30	78.50 1.000e-5
3	Concrete C 30	3.150e+7 3.150e+7	0.20 0.20	25.00 1.000e-5

Slab sets

No	t[m]	e[m]	Material	Analysis type	E2[kN/m ²] G[kN/m ²]
			α	Orthotropy	
<1>	0.200	0.100	1	Thin slab Isotropy	
<2>	0.220	0.110	1	Thin slab Isotropy	
<3>	0.250	0.125	1 0.00	Thin slab Unisotropy	0.000e+0 0.000e+0
<5>	0.600	0.300	1	Thick slab Isotropy	
<6>	0.300	0.150	1	Thin slab Isotropy	
<7>	0.007	0.004	2	Thin slab Isotropy	

Beam sets

Set: 1 Section: b/d=30/50, Approx. eccentricity, Beams all level

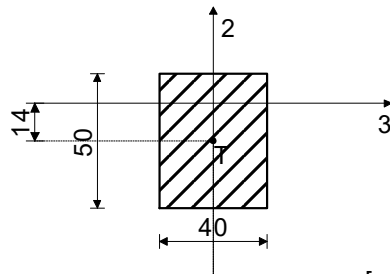

Mat.	A1	A2	A3	I1	I2	I3
1 - C 30/37	2.000e-1	1.667e-1	1.667e-1	5.474e-3	2.667e-3	4.167e-3

Set: 2 Section: b/d=40/50, Approx. eccentricity

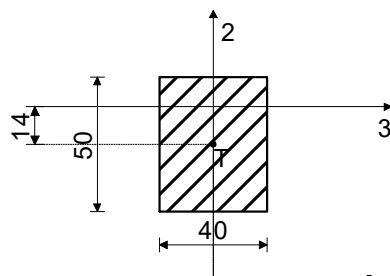

Mat.	A1	A2	A3	I1	I2	I3
1 - C 30/37	2.000e-1	1.667e-1	1.667e-1	5.474e-3	2.667e-3	4.167e-3

Set: 4 Section: b/d=40/60, Approx. eccentricity

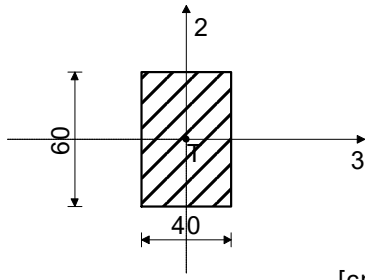

[cm]

Mat.	A1	A2	A3	I1	I2	I3
3 - Concrete C 30	2.400e-1	2.000e-1	2.000e-1	7.512e-3	3.200e-3	7.200e-3

Set: 5 Section: b/d=50/50, Approx. eccentricity

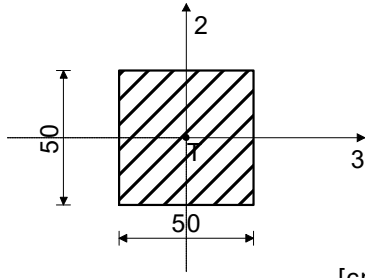

[cm]

Mat.	A1	A2	A3	I1	I2	I3
1 - C 30/37	2.500e-1	2.083e-1	2.083e-1	8.802e-3	5.208e-3	5.208e-3

Set: 6 Section: HOP □ 100x100x5, Approx. eccentricity

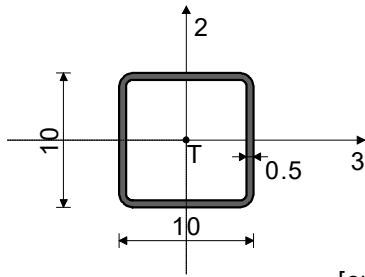

[cm]

Mat.	A1	A2	A3	I1	I2	I3
2 - Steel	1.836e-3	1.000e-3	1.000e-3	4.390e-6	2.618e-6	2.618e-6

Set: 7 Section: HOP □ 80x50x4, Approx. eccentricity

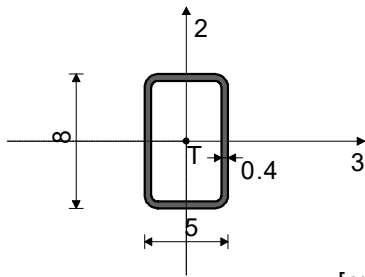

[cm]

Mat.	A1	A2	A3	I1	I2	I3
2 - Steel	9.350e-4	6.400e-4	4.000e-4	8.220e-7	3.443e-7	7.253e-7

Set: 8 Section: HOP □ 100x100x8, Approx. eccentricity

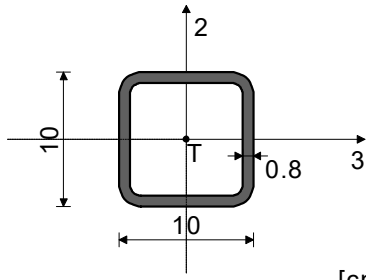

[cm]

Mat.	A1	A2	A3	I1	I2	I3
2 - Steel	2.779e-3	1.600e-3	1.600e-3	6.408e-6	3.798e-6	3.798e-6

Set: 9 Section: HOP □ 80x50x4, Approx. eccentricity

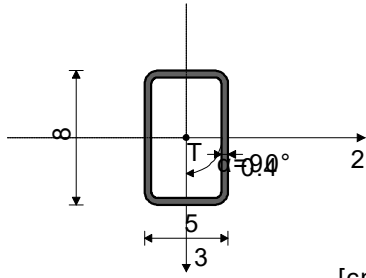

[cm]

Mat.	A1	A2	A3	I1	I2	I3
2 - Steel	9.350e-4	4.000e-4	6.400e-4	8.220e-7	7.253e-7	3.443e-7

Set: 10 Section: HOP □ 80x80x5, Approx. eccentricity

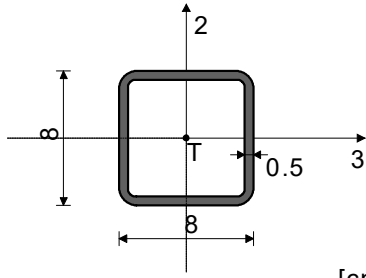

[cm]

Mat.	A1	A2	A3	I1	I2	I3
2 - Steel	1.436e-3	8.000e-4	8.000e-4	2.166e-6	1.244e-6	1.244e-6

Area support sets

Set	K,R1	K,R2	K,R3
1	1.000e+10	1.000e+10	5.000e+4

Linear support sets

Set	K,R1	K,R2	K,R3	K,M1	Soil [m]
3	1.000e+10	1.000e+10	1.000e+10	1.000e+10	0.700

Input data - Load

Load cases list

LC	Name
1	DEAD (g)
2	LIVE C 1
3	LIVE E
4	WIND
5	SX (+e)
6	SX (-e)
7	SY (+e)
8	SY (-e)
9	SRSS: MAX(V,VI)+MAX(VII,VIII)
10	Comb.: 1.35xI+1.05xII+1.5xIII+1.5xIV
11	Comb.: 1.35xI+1.5xII+1.5xIII+0.9xIV
12	Comb.: I+1.05xII+1.5xIII+1.5xIV
13	Comb.: I+1.5xII+1.5xIII+0.9xIV
14	Comb.: 1.35xI+1.05xII+1.5xIII+0.9xIV
15	Comb.: I+1.05xII+1.5xIII+0.9xIV
16	Comb.: 1.35xI+1.5xIII+1.5xIV
17	Comb.: 1.35xI+1.5xII+1.5xIII
18	Comb.: I+1.5xIII+1.5xIV
19	Comb.: I+1.5xII+1.5xIII
20	Comb.: 1.35xI+1.05xII+1.5xIV
21	Comb.: 1.35xI+1.05xII+1.5xIII
22	Comb.: 1.35xI+1.5xIII+0.9xIV
23	Comb.: 1.35xI+1.5xII+0.9xIV
24	Comb.: I+1.05xII+1.5xIV
25	Comb.: I+1.05xII+1.5xIII
26	Comb.: I+1.5xIII+0.9xIV
27	Comb.: I+1.5xII+0.9xIV
28	Comb.: 1.35xI+1.5xIV
29	Comb.: 1.35xI+1.5xIII
30	Comb.: 1.35xI+1.5xII
31	Comb.: I+1.5xIV
32	Comb.: I+1.5xIII
33	Comb.: I+1.5xII
34	Comb.: 1.35xI
35	Comb.: I

Load 1: DEAD (g)

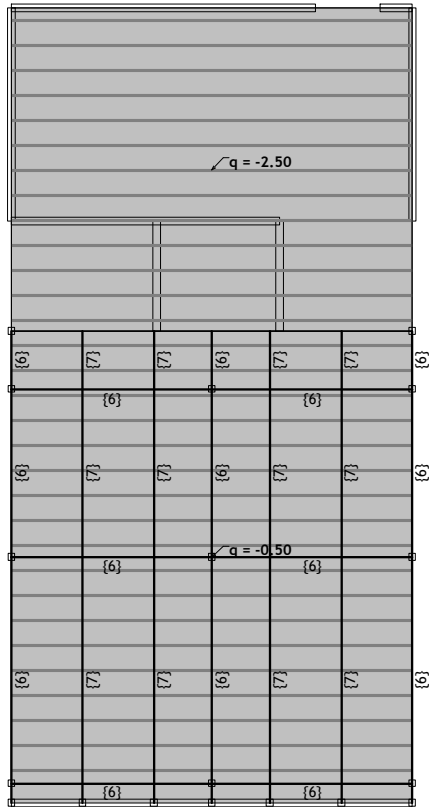

Level: Kafazi i shkalleve [10.96 m]

Load 1: DEAD (g)

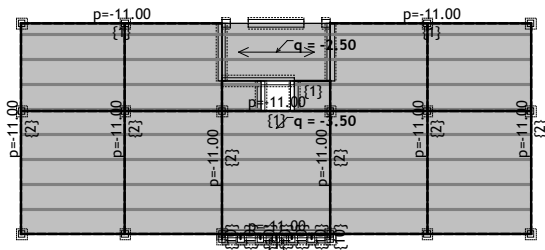

Level: 1 [3.85 m]

Load 1: DEAD (g)

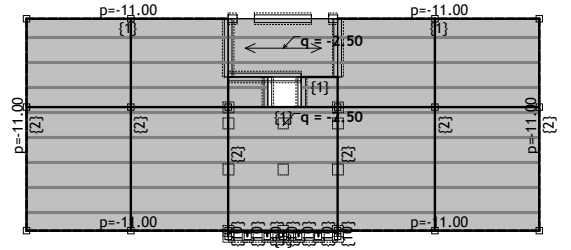

Level: Tarraca [7.70 m]

Load 1: DEAD (g)

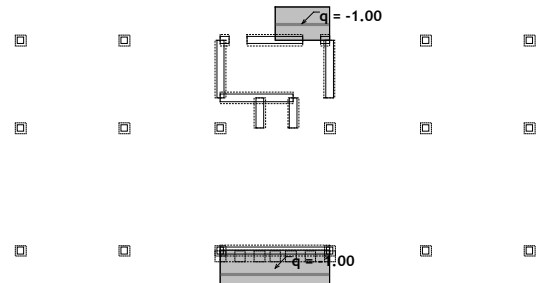

Level: streha [2.77 m]

Load 1: DEAD (g)

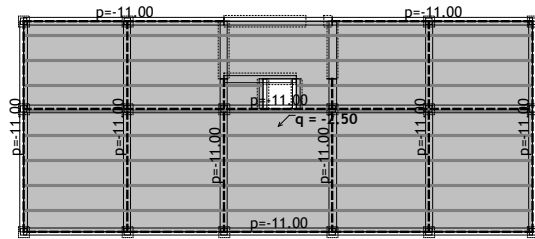

Level: 0 [0.00 m]
Load 2: LIVE C 1

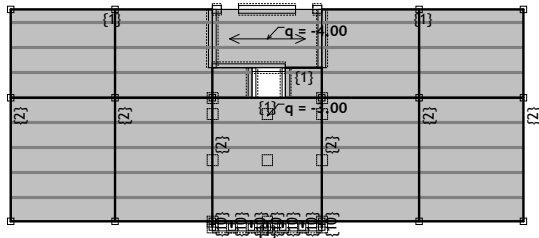

Level: Tarraca [7.70 m]

Load 2: LIVE C 1

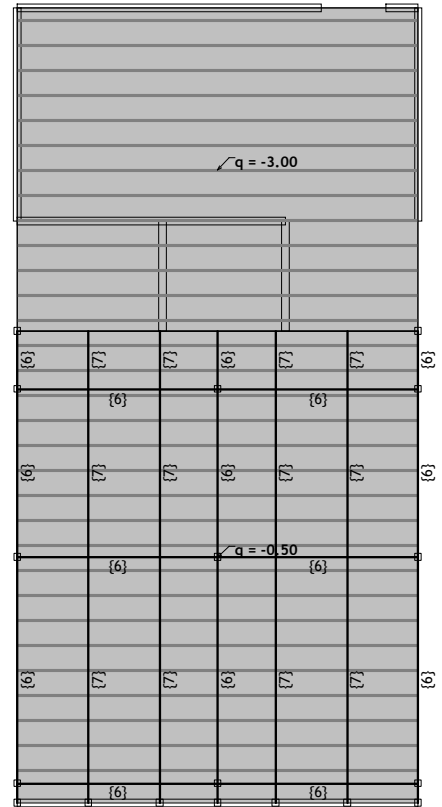

Level: Kafazi i shkalleve [10.96 m]
Load 2: LIVE C 1

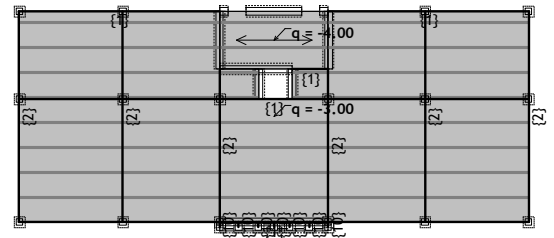

Level: 1 [3.85 m]

Load 2: LIVE C 1

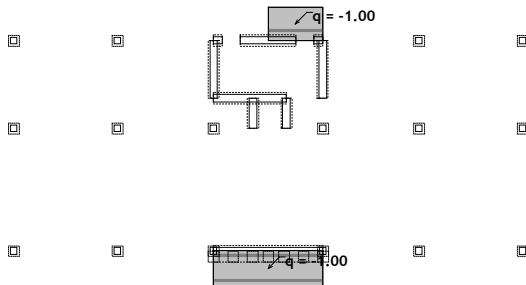

Level: streha [2.77 m]
Load 3: LIVE E

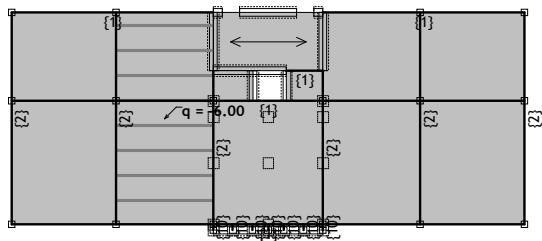

Level: Tarraca [7.70 m]

Load 2: LIVE C 1

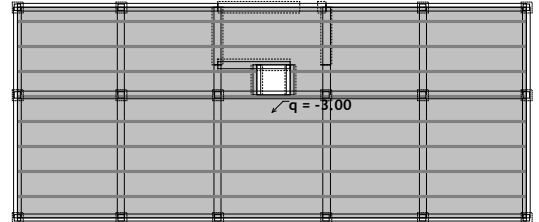

Level: 0 [0.00 m]
Load 4: WIND

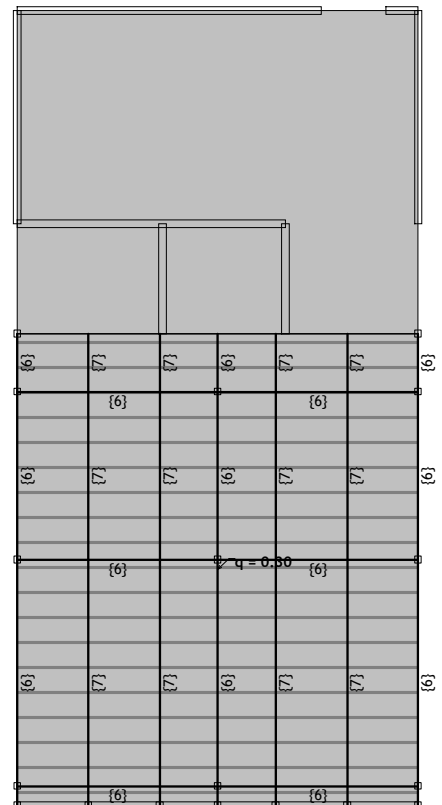

Level: Kafazi i shkalleve [10.96 m]

Load 4: WIND

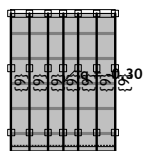

Frame: H 8

Advanced options of seismic analysis:

Masses grouped in the selected ceilings levels

Load factors for mass calculations

No	Name	Factor
1	DEAD (g)	1.00
2	LIVE C 1	0.60
3	LIVE E	0.80
4	WIND	0.00

Mass distribution per levels

Level	Z [m]	X [m]	Y [m]	Mass [T]	T/m ²
Kafazi i shkalleve	10.96	0.60	-39.72	66.40	0.87
Tarraca	7.70	0.43	-42.31	608.54	1.77
1	3.85	0.74	-42.51	730.54	2.12
0	0.00	0.74	-42.46	708.02	2.05
Themeli	-2.50	0.74	-41.75	343.21	3.06
Total:	3.00	0.66	-42.27	2456.71	

Position of rigidity centers (approximative)

Level	Z [m]	X [m]	Y [m]
Kafazi i shkalleve	10.96	0.75	-39.78
Tarraca	7.70	0.76	-41.40
1	3.85	0.76	-43.97
0	0.00	0.75	-44.55
Themeli	-2.50	0.75	-44.57

Eccentricity per levels (approximative)

Level	Z [m]	eox [m]	eoy [m]
Kafazi i shkalleve	10.96	0.15	0.07
Tarraca	7.70	0.33	0.91
1	3.85	0.02	1.46
0	0.00	0.01	2.08
Themeli	-2.50	0.01	2.82

Natural frequency of structure

No	T [s]	f [Hz]
1	0.2916	3.4295
2	0.2054	4.8682
3	0.1802	5.5487
4	0.1793	5.5779
5	0.1760	5.6810
6	0.1725	5.7982
7	0.1711	5.8441
8	0.1461	6.8459
9	0.1436	6.9652
10	0.1384	7.2259
11	0.1373	7.2836
12	0.1070	9.3482
13	0.1040	9.6174
14	0.1029	9.7154
15	0.0990	10.1038

No	T [s]	f [Hz]
16	0.0940	10.6420
17	0.0933	10.7179
18	0.0929	10.7638
19	0.0928	10.7775
20	0.0898	11.1364
21	0.0880	11.3688
22	0.0854	11.7033
23	0.0826	12.1109
24	0.0821	12.1777
25	0.0752	13.2898
26	0.0716	13.9708
27	0.0695	14.3987
28	0.0693	14.4396
29	0.0675	14.8194
30	0.0671	14.8978

Seismic analysis

Seismic analysis: EC8 (EN 1998)

Soil category:	C
Importance factor:	IV ($\gamma=1.4$)
Ratio $a_g R/g$:	0.320
Damping coefficient:	0.05
Accidental torsional effects:	$e_i = \pm 0.050 \times L_i$

Earthquake directional factors:

Load case	Angle α [°]	k, α	$k, \alpha+90^\circ$	k_z	q
SX	0	1.000	0.300	0.000	3.450
SY	90	1.000	0.300	0.000	3.450

Type of spectrum

Load case	S	T _b	T _c	T _d	avg/a _g
SX	1.150	0.200	0.600	2.000	1.000
SY	1.150	0.200	0.600	2.000	1.000

Design spectrum

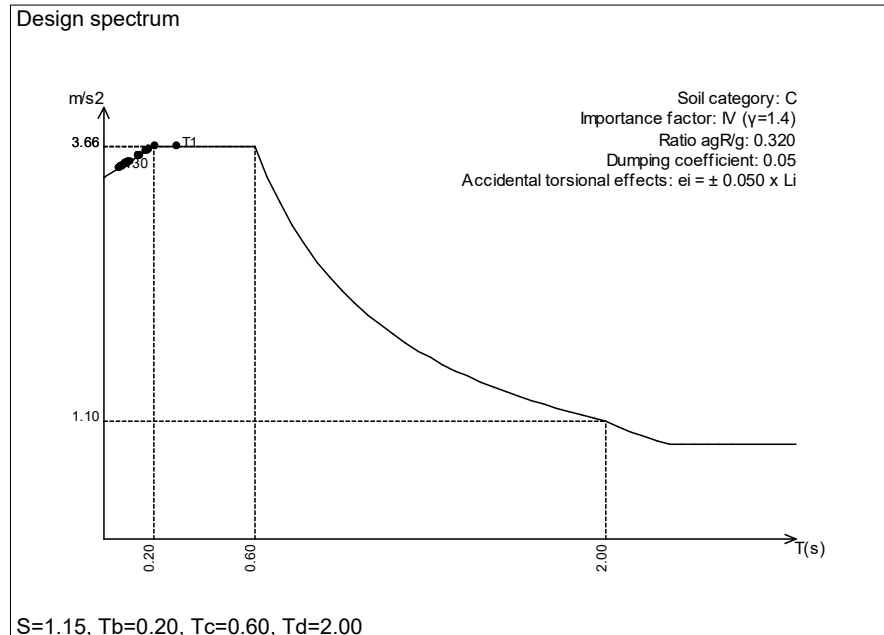

Distribution of seismic forces along height of structure - SX (+e)

Level	Z [m]	Mode 1			Mode 2		
		P _x [kN]	P _y [kN]	P _z [kN]	P _x [kN]	P _y [kN]	P _z [kN]
Kafazi i shkalleve	10.96	23.35	24.07	-0.77	63.38	184.34	0.51
Tarraca	7.70	507.48	141.33	0.84	347.93	1280.8	15.19
1	3.85	393.20	108.59	-0.94	174.59	760.54	4.13
streha	2.77	0.00	0.00	0.00	0.00	0.00	0.00
0	0.00	4.64	2.77	-1.03	4.07	28.27	0.47
Themeli	-2.50	0.00	0.00	-1.09	0.00	0.00	-2.61
	$\Sigma=$	928.68	276.76	-2.98	589.97	2254.0	17.69

Level	Z [m]	Mode 3			Mode 4		
		P _x [kN]	P _y [kN]	P _z [kN]	P _x [kN]	P _y [kN]	P _z [kN]
Kafazi i shkalleve	10.96	0.99	0.47	-0.02	0.76	0.68	-0.01
Tarraca	7.70	6.50	3.21	0.03	4.44	4.69	0.05
1	3.85	3.80	-2.94	-0.02	2.72	-2.26	-0.01
streha	2.77	0.00	0.00	0.00	0.00	0.00	0.00
0	0.00	0.10	0.04	-0.02	0.07	0.07	-0.01
Themeli	-2.50	0.00	0.00	-0.03	0.00	0.00	-0.02
	$\Sigma=$	11.40	0.78	-0.05	7.99	3.18	0.00

Level	Z [m]	Mode 5			Mode 6		
		P _x [kN]	P _y [kN]	P _z [kN]	P _x [kN]	P _y [kN]	P _z [kN]
Kafazi i shkalleve	10.96	5.36	0.76	-0.13	24.56	-4.19	-0.73
Tarraca	7.70	34.44	5.29	0.03	155.15	-27.07	-0.52
1	3.85	21.03	-14.49	-0.17	99.29	-48.55	-1.12
streha	2.77	0.00	0.00	0.00	0.00	0.00	0.00
0	0.00	0.59	-0.04	-0.12	2.83	-1.03	-0.65
Themeli	-2.50	0.00	-0.00	-0.13	0.00	-0.00	-0.57
	$\Sigma=$	61.43	-8.47	-0.52	281.83	-80.84	-3.58

Level	Z [m]	Mode 7			Mode 8		
		Px [kN]	Py [kN]	Pz [kN]	Px [kN]	Py [kN]	Pz [kN]
Kafazi i shkalleve	10.96	238.31	-94.15	-8.11	-0.00	0.00	-0.00
Tarraca	7.70	1524.7	-625.49	-9.57	-0.00	0.00	0.00
1	3.85	985.95	-330.85	-13.20	0.00	0.00	0.00
streha	2.77	0.00	0.00	0.00	0.00	0.00	0.00
0	0.00	28.50	-16.03	-6.98	-0.00	0.00	0.00
Themeli	-2.50	0.00	-0.00	-5.35	-0.00	0.00	-0.00
	$\Sigma=$	2777.4	-1066.52	-43.21	-0.00	0.00	-0.00

Level	Z [m]	Mode 9			Mode 10		
		Px [kN]	Py [kN]	Pz [kN]	Px [kN]	Py [kN]	Pz [kN]
Kafazi i shkalleve	10.96	0.01	-0.01	0.79	0.00	-0.00	-0.00
Tarraca	7.70	0.07	-0.12	0.46	-0.00	0.00	-0.00
1	3.85	0.05	-0.08	0.04	0.00	0.00	-0.00
streha	2.77	0.00	0.00	0.00	0.00	0.00	0.00
0	0.00	0.00	-0.00	0.00	0.00	0.00	-0.00
Themeli	-2.50	0.00	-0.00	0.00	0.00	0.00	-0.00
	$\Sigma=$	0.14	-0.21	1.30	0.00	0.00	-0.00

Level	Z [m]	Mode 11			Mode 12		
		Px [kN]	Py [kN]	Pz [kN]	Px [kN]	Py [kN]	Pz [kN]
Kafazi i shkalleve	10.96	0.01	-0.10	-0.00	-0.03	-0.02	-0.06
Tarraca	7.70	0.06	-0.64	-0.01	-0.52	0.10	-1.66
1	3.85	0.10	0.80	-0.01	0.89	0.13	-0.14
streha	2.77	0.00	0.00	0.00	0.00	0.00	0.00
0	0.00	0.00	-0.00	-0.00	0.01	0.01	-0.01
Themeli	-2.50	0.00	0.00	-0.00	0.00	0.00	-0.01
	$\Sigma=$	0.17	0.05	-0.02	0.35	0.22	-1.87

Level	Z [m]	Mode 13			Mode 14		
		Px [kN]	Py [kN]	Pz [kN]	Px [kN]	Py [kN]	Pz [kN]
Kafazi i shkalleve	10.96	-0.94	-0.42	-3.55	-1.72	-0.68	5.03
Tarraca	7.70	-14.54	2.53	-27.88	-29.09	-1.12	22.78
1	3.85	18.87	3.71	-2.34	40.92	4.71	1.43
streha	2.77	0.00	0.00	0.00	0.00	0.00	0.00
0	0.00	0.12	0.19	-0.23	0.33	0.22	0.27
Themeli	-2.50	0.00	0.00	-0.13	0.00	0.00	0.15
	$\Sigma=$	3.51	6.02	-34.14	10.45	3.12	29.64

Level	Z [m]	Mode 15			Mode 16		
		Px [kN]	Py [kN]	Pz [kN]	Px [kN]	Py [kN]	Pz [kN]
Kafazi i shkalleve	10.96	-0.25	-0.16	-1.70	-0.06	0.04	0.09
Tarraca	7.70	-4.13	-0.23	18.00	-1.08	0.42	-8.34
1	3.85	5.35	2.25	0.70	1.65	-0.61	7.88
streha	2.77	0.00	0.00	0.00	0.00	0.00	0.00
0	0.00	0.06	0.15	0.06	0.03	0.00	0.00
Themeli	-2.50	0.00	0.00	0.00	0.00	-0.00	0.01
	$\Sigma=$	1.02	2.02	17.07	0.54	-0.14	-0.35

Level	Z [m]	Mode 17			Mode 18		
		Px [kN]	Py [kN]	Pz [kN]	Px [kN]	Py [kN]	Pz [kN]
Kafazi i shkalleve	10.96	-0.01	-0.01	0.01	0.00	-0.01	-0.05
Tarraca	7.70	-0.07	-0.01	-0.59	-0.03	0.04	-0.32
1	3.85	0.10	0.03	-2.42	0.02	0.08	-0.39
streha	2.77	0.00	0.00	0.00	0.00	0.00	0.00
0	0.00	-0.00	-0.01	-0.02	0.01	0.00	-0.01
Themeli	-2.50	0.00	0.00	-0.01	-0.00	0.00	-0.01
	$\Sigma=$	0.02	-0.01	-3.03	-0.01	0.11	-0.77

Level	Z [m]	Mode 19			Mode 20		
		Px [kN]	Py [kN]	Pz [kN]	Px [kN]	Py [kN]	Pz [kN]
Kafazi i shkalleve	10.96	0.01	-0.01	0.06	-0.07	-0.15	0.56
Tarraca	7.70	-0.20	0.01	-3.02	-0.10	0.19	3.23
1	3.85	0.37	-0.24	-4.50	1.78	2.13	6.17
streha	2.77	0.00	0.00	0.00	0.00	0.00	0.00
0	0.00	0.04	-0.05	-0.03	0.16	0.20	-0.05
Themeli	-2.50	0.00	-0.00	-0.01	0.00	0.00	-0.07
	$\Sigma=$	0.22	-0.29	-7.51	1.77	2.38	9.84

Level	Z [m]	Mode 21			Mode 22		
		Px [kN]	Py [kN]	Pz [kN]	Px [kN]	Py [kN]	Pz [kN]
Kafazi i shkalleve	10.96	-0.01	-0.01	0.02	-0.00	-0.01	-0.01
Tarraca	7.70	0.03	0.03	-0.20	-0.01	0.01	-0.01
1	3.85	-0.00	0.12	0.13	-0.01	0.07	-0.41
streha	2.77	0.00	0.00	0.00	0.00	0.00	0.00
0	0.00	0.00	0.01	-0.01	-0.00	0.00	-0.01
Themeli	-2.50	0.00	0.00	-0.01	-0.00	0.00	-0.01
	$\Sigma=$	0.02	0.15	-0.05	-0.02	0.09	-0.44

Level	Z [m]	Mode 23			Mode 24		
		Px [kN]	Py [kN]	Pz [kN]	Px [kN]	Py [kN]	Pz [kN]
Kafazi i shkalleve	10.96	-0.00	0.12	-0.20	-0.04	-0.02	0.01
Tarraca	7.70	0.55	-0.53	6.39	0.19	0.00	-0.52
1	3.85	0.39	-0.78	0.17	0.32	0.10	0.00
streha	2.77	0.00	0.00	0.00	0.00	0.00	0.00
0	0.00	0.06	-0.06	0.10	0.09	0.01	-0.01
Themeli	-2.50	0.00	-0.00	0.06	0.00	0.00	-0.01
	$\Sigma=$	1.00	-1.25	6.52	0.56	0.09	-0.54

Level	Z [m]	Mode 25			Mode 26		
		Px [kN]	Py [kN]	Pz [kN]	Px [kN]	Py [kN]	Pz [kN]
Kafazi i shkalleve	10.96	-0.03	-0.28	-0.03	0.00	-0.03	0.07
Tarraca	7.70	-0.05	-0.28	-2.82	0.14	-0.50	-0.34
1	3.85	-0.07	2.29	0.48	0.18	0.31	3.95
streha	2.77	0.00	0.00	0.00	0.00	0.00	0.00
0	0.00	0.01	0.12	-0.06	0.01	-0.03	0.08
Themeli	-2.50	-0.00	0.00	-0.05	0.00	-0.00	0.06
	$\Sigma=$	-0.14	1.85	-2.48	0.33	-0.25	3.84

Level	Z [m]	Mode 27			Mode 28		
		Px [kN]	Py [kN]	Pz [kN]	Px [kN]	Py [kN]	Pz [kN]
Kafazi i shkalleve	10.96	-0.03	-0.08	0.01	-6.39	-31.70	-0.93
Tarraca	7.70	-0.03	-0.37	-0.07	-12.47	-137.68	-41.87
1	3.85	0.19	0.98	-0.04	41.34	368.95	-13.16
streha	2.77	0.00	0.00	0.00	0.00	0.00	0.00
0	0.00	0.01	0.04	-0.00	1.87	15.93	-1.43
Themeli	-2.50	0.00	0.00	-0.00	0.00	0.00	-1.41
	$\Sigma=$	0.15	0.57	-0.11	24.35	215.50	-58.80

Level	Z [m]	Mode 29			Mode 30		
		Px [kN]	Py [kN]	Pz [kN]	Px [kN]	Py [kN]	Pz [kN]
Kafazi i shkalleve	10.96	-0.69	-0.78	-0.18	-0.17	-1.01	-0.15
Tarraca	7.70	-0.58	-3.01	12.35	-0.30	-4.49	18.51
1	3.85	5.00	7.61	0.18	0.93	11.24	2.50
streha	2.77	0.00	0.00	0.00	0.00	0.00	0.00
0	0.00	0.34	0.23	-0.06	-0.02	0.27	0.09
Themeli	-2.50	0.00	0.00	-0.12	0.00	0.00	-0.04
	$\Sigma=$	4.07	4.06	12.17	0.45	6.01	20.92

Distribution of seismic forces along height of structure - SX (-e)

Level	Z [m]	Mode 1			Mode 2		
		Px [kN]	Py [kN]	Pz [kN]	Px [kN]	Py [kN]	Pz [kN]
Kafazi i shkalleve	10.96	23.35	24.07	-0.77	63.38	184.34	0.51
Tarraca	7.70	507.48	141.33	0.84	347.93	1280.8	15.19
1	3.85	393.20	108.59	-0.94	174.59	760.54	4.13
streha	2.77	0.00	0.00	0.00	0.00	0.00	0.00
0	0.00	4.64	2.77	-1.03	4.07	28.27	0.47
Themeli	-2.50	0.00	0.00	-1.09	0.00	0.00	-2.61
	$\Sigma=$	928.68	276.76	-2.98	589.97	2254.0	17.69

Level	Z [m]	Mode 3			Mode 4		
		Px [kN]	Py [kN]	Pz [kN]	Px [kN]	Py [kN]	Pz [kN]
Kafazi i shkalleve	10.96	0.99	0.47	-0.02	0.76	0.68	-0.01
Tarraca	7.70	6.50	3.21	0.03	4.44	4.69	0.05
1	3.85	3.80	-2.94	-0.02	2.72	-2.26	-0.01
streha	2.77	0.00	0.00	0.00	0.00	0.00	0.00
0	0.00	0.10	0.04	-0.02	0.07	0.07	-0.01
Themeli	-2.50	0.00	0.00	-0.03	0.00	0.00	-0.02
	$\Sigma=$	11.40	0.78	-0.05	7.99	3.18	0.00

Level	Z [m]	Mode 5			Mode 6		
		Px [kN]	Py [kN]	Pz [kN]	Px [kN]	Py [kN]	Pz [kN]
Kafazi i shkalleve	10.96	5.36	0.76	-0.13	24.56	-4.19	-0.73
Tarraca	7.70	34.44	5.29	0.03	155.15	-27.07	-0.52
1	3.85	21.03	-14.49	-0.17	99.29	-48.55	-1.12
streha	2.77	0.00	0.00	0.00	0.00	0.00	0.00
0	0.00	0.59	-0.04	-0.12	2.83	-1.03	-0.65
Themeli	-2.50	0.00	-0.00	-0.13	0.00	-0.00	-0.57
	$\Sigma=$	61.43	-8.47	-0.52	281.83	-80.84	-3.58

Level	Z [m]	Mode 7			Mode 8		
		Px [kN]	Py [kN]	Pz [kN]	Px [kN]	Py [kN]	Pz [kN]
Kafazi i shkalleve	10.96	238.31	-94.15	-8.11	-0.00	0.00	-0.00
Tarraca	7.70	1524.7	-625.49	-9.57	-0.00	0.00	0.00
1	3.85	985.95	-330.85	-13.20	0.00	0.00	0.00
streha	2.77	0.00	0.00	0.00	0.00	0.00	0.00
0	0.00	28.50	-16.03	-6.98	-0.00	0.00	0.00
Themeli	-2.50	0.00	-0.00	-5.35	-0.00	0.00	-0.00
	$\Sigma=$	2777.4	-1066.52	-43.21	-0.00	0.00	-0.00

Level	Z [m]	Mode 9			Mode 10		
		Px [kN]	Py [kN]	Pz [kN]	Px [kN]	Py [kN]	Pz [kN]
Kafazi i shkalleve	10.96	0.01	-0.01	0.79	0.00	-0.00	-0.00
Tarraca	7.70	0.07	-0.12	0.46	-0.00	0.00	-0.00
1	3.85	0.05	-0.08	0.04	0.00	0.00	-0.00
streha	2.77	0.00	0.00	0.00	0.00	0.00	0.00
0	0.00	0.00	-0.00	0.00	0.00	0.00	-0.00
Themeli	-2.50	0.00	-0.00	0.00	0.00	0.00	-0.00
	$\Sigma=$	0.14	-0.21	1.30	0.00	0.00	-0.00

Level	Z [m]	Mode 11			Mode 12		
		Px [kN]	Py [kN]	Pz [kN]	Px [kN]	Py [kN]	Pz [kN]
Kafazi i shkalleve	10.96	0.01	-0.10	-0.00	-0.03	-0.02	-0.06
Tarraca	7.70	0.06	-0.64	-0.01	-0.52	0.10	-1.66
1	3.85	0.10	0.80	-0.01	0.89	0.13	-0.14
streha	2.77	0.00	0.00	0.00	0.00	0.00	0.00
0	0.00	0.00	-0.00	-0.00	0.01	0.01	-0.01
Themeli	-2.50	0.00	0.00	-0.00	0.00	0.00	-0.01
	$\Sigma=$	0.17	0.05	-0.02	0.35	0.22	-1.87

Level	Z [m]	Mode 13			Mode 14		
		Px [kN]	Py [kN]	Pz [kN]	Px [kN]	Py [kN]	Pz [kN]
Kafazi i shkalleve	10.96	-0.94	-0.42	-3.55	-1.72	-0.68	5.03
Tarraca	7.70	-14.54	2.53	-27.88	-29.09	-1.12	22.78
1	3.85	18.87	3.71	-2.34	40.92	4.71	1.43
streha	2.77	0.00	0.00	0.00	0.00	0.00	0.00
0	0.00	0.12	0.19	-0.23	0.33	0.22	0.27
Themeli	-2.50	0.00	0.00	-0.13	0.00	0.00	0.15
	$\Sigma=$	3.51	6.02	-34.14	10.45	3.12	29.64

Level	Z [m]	Mode 15			Mode 16		
		Px [kN]	Py [kN]	Pz [kN]	Px [kN]	Py [kN]	Pz [kN]
Kafazi i shkalleve	10.96	-0.25	-0.16	-1.70	-0.06	0.04	0.09
Tarraca	7.70	-4.13	-0.23	18.00	-1.08	0.42	-8.34
1	3.85	5.35	2.25	0.70	1.65	-0.61	7.88
streha	2.77	0.00	0.00	0.00	0.00	0.00	0.00
0	0.00	0.06	0.15	0.06	0.03	0.00	0.00
Themeli	-2.50	0.00	0.00	0.00	0.00	-0.00	0.01
	$\Sigma=$	1.02	2.02	17.07	0.54	-0.14	-0.35

Level	Z [m]	Mode 17			Mode 18		
		Px [kN]	Py [kN]	Pz [kN]	Px [kN]	Py [kN]	Pz [kN]
Kafazi i shkalleve	10.96	-0.01	-0.01	0.01	0.00	-0.01	-0.05
Tarraca	7.70	-0.07	-0.01	-0.59	-0.03	0.04	-0.32
1	3.85	0.10	0.03	-2.42	0.02	0.08	-0.39
streha	2.77	0.00	0.00	0.00	0.00	0.00	0.00
0	0.00	-0.00	-0.01	-0.02	0.01	0.00	-0.01
Themeli	-2.50	0.00	0.00	-0.01	-0.00	0.00	-0.01
	$\Sigma=$	0.02	-0.01	-3.03	-0.01	0.11	-0.77

Level	Z [m]	Mode 19			Mode 20		
		Px [kN]	Py [kN]	Pz [kN]	Px [kN]	Py [kN]	Pz [kN]
Kafazi i shkalleve	10.96	0.01	-0.01	0.06	-0.07	-0.15	0.56
Tarraca	7.70	-0.20	0.01	-3.02	-0.10	0.19	3.23
1	3.85	0.37	-0.24	-4.50	1.78	2.13	6.17
streha	2.77	0.00	0.00	0.00	0.00	0.00	0.00
0	0.00	0.04	-0.05	-0.03	0.16	0.20	-0.05
Themeli	-2.50	0.00	-0.00	-0.01	0.00	0.00	-0.07
	$\Sigma=$	0.22	-0.29	-7.51	1.77	2.38	9.84

Level	Z [m]	Mode 21			Mode 22		
		Px [kN]	Py [kN]	Pz [kN]	Px [kN]	Py [kN]	Pz [kN]
Kafazi i shkalleve	10.96	-0.01	-0.01	0.02	-0.00	-0.01	-0.01
Tarraca	7.70	0.03	0.03	-0.20	-0.01	0.01	-0.01
1	3.85	-0.00	0.12	0.13	-0.01	0.07	-0.41
streha	2.77	0.00	0.00	0.00	0.00	0.00	0.00
0	0.00	0.00	0.01	-0.01	-0.00	0.00	-0.01
Themeli	-2.50	0.00	0.00	-0.01	-0.00	0.00	-0.01
	$\Sigma=$	0.02	0.15	-0.05	-0.02	0.09	-0.44

Level	Z [m]	Mode 23			Mode 24		
		Px [kN]	Py [kN]	Pz [kN]	Px [kN]	Py [kN]	Pz [kN]
Kafazi i shkalleve	10.96	-0.00	0.12	-0.20	-0.04	-0.02	0.01
Tarraca	7.70	0.55	-0.53	6.39	0.19	0.00	-0.52
1	3.85	0.39	-0.78	0.17	0.32	0.10	0.00
streha	2.77	0.00	0.00	0.00	0.00	0.00	0.00
0	0.00	0.06	-0.06	0.10	0.09	0.01	-0.01
Themeli	-2.50	0.00	-0.00	0.06	0.00	0.00	-0.01
	$\Sigma=$	1.00	-1.25	6.52	0.56	0.09	-0.54

Level	Z [m]	Mode 25			Mode 26		
		Px [kN]	Py [kN]	Pz [kN]	Px [kN]	Py [kN]	Pz [kN]
Kafazi i shkalleve	10.96	-0.03	-0.28	-0.03	0.00	-0.03	0.07
Tarraca	7.70	-0.05	-0.28	-2.82	0.14	-0.50	-0.34
1	3.85	-0.07	2.29	0.48	0.18	0.31	3.95
streha	2.77	0.00	0.00	0.00	0.00	0.00	0.00
0	0.00	0.01	0.12	-0.06	0.01	-0.03	0.08
Themeli	-2.50	-0.00	0.00	-0.05	0.00	-0.00	0.06
	$\Sigma=$	-0.14	1.85	-2.48	0.33	-0.25	3.84

Level	Z [m]	Mode 27			Mode 28		
		Px [kN]	Py [kN]	Pz [kN]	Px [kN]	Py [kN]	Pz [kN]
Kafazi i shkalleve	10.96	-0.03	-0.08	0.01	-6.39	-31.70	-0.93
Tarraca	7.70	-0.03	-0.37	-0.07	-12.47	-137.68	-41.87
1	3.85	0.19	0.98	-0.04	41.34	368.95	-13.16
streha	2.77	0.00	0.00	0.00	0.00	0.00	0.00
0	0.00	0.01	0.04	-0.00	1.87	15.93	-1.43
Themeli	-2.50	0.00	0.00	-0.00	0.00	0.00	-1.41
	$\Sigma=$	0.15	0.57	-0.11	24.35	215.50	-58.80

Level	Z [m]	Mode 29			Mode 30		
		Px [kN]	Py [kN]	Pz [kN]	Px [kN]	Py [kN]	Pz [kN]
Kafazi i shkalleve	10.96	-0.69	-0.78	-0.18	-0.17	-1.01	-0.15
Tarraca	7.70	-0.58	-3.01	12.35	-0.30	-4.49	18.51
1	3.85	5.00	7.61	0.18	0.93	11.24	2.50
streha	2.77	0.00	0.00	0.00	0.00	0.00	0.00
0	0.00	0.34	0.23	-0.06	-0.02	0.27	0.09
Themeli	-2.50	0.00	0.00	-0.12	0.00	0.00	-0.04
	$\Sigma=$	4.07	4.06	12.17	0.45	6.01	20.92

Distribution of seismic forces along height of structure - SY (+e)

Level	Z [m]	Mode 1			Mode 2		
		Px [kN]	Py [kN]	Pz [kN]	Px [kN]	Py [kN]	Pz [kN]
Kafazi i shkalleve	10.96	-0.04	-0.04	0.00	103.97	302.39	0.83
Tarraca	7.70	-0.93	-0.26	-0.00	570.74	2101.1	24.91
1	3.85	-0.72	-0.20	0.00	286.39	1247.6	6.77
streha	2.77	0.00	0.00	0.00	0.00	0.00	0.00
0	0.00	-0.01	-0.01	0.00	6.67	46.38	0.78
Themeli	-2.50	-0.00	-0.00	0.00	0.00	0.00	-4.27
	$\Sigma=$	-1.69	-0.50	0.01	967.77	3697.4	29.02

Level	Z [m]	Mode 3			Mode 4		
		Px [kN]	Py [kN]	Pz [kN]	Px [kN]	Py [kN]	Pz [kN]
Kafazi i shkalleve	10.96	-0.23	-0.11	0.00	0.07	0.06	-0.00
Tarraca	7.70	-1.48	-0.73	-0.01	0.39	0.41	0.00
1	3.85	-0.86	0.67	0.01	0.24	-0.20	-0.00
streha	2.77	0.00	0.00	0.00	0.00	0.00	0.00
0	0.00	-0.02	-0.01	0.00	0.01	0.01	-0.00
Themeli	-2.50	-0.00	-0.00	0.01	0.00	0.00	-0.00
	$\Sigma=$	-2.59	-0.18	0.01	0.70	0.28	0.00

Level	Z [m]	Mode 5			Mode 6		
		Px [kN]	Py [kN]	Pz [kN]	Px [kN]	Py [kN]	Pz [kN]
Kafazi i shkalleve	10.96	-2.45	-0.35	0.06	-15.77	2.69	0.47
Tarraca	7.70	-15.73	-2.42	-0.01	-99.62	17.38	0.33
1	3.85	-9.61	6.62	0.08	-63.75	31.17	0.72
streha	2.77	0.00	0.00	0.00	0.00	0.00	0.00
0	0.00	-0.27	0.02	0.06	-1.82	0.66	0.42
Themeli	-2.50	-0.00	0.00	0.06	-0.00	0.00	0.36
	$\Sigma=$	-28.06	3.87	0.24	-180.96	51.90	2.30

Level	Z [m]	Mode 7			Mode 8		
		Px [kN]	Py [kN]	Pz [kN]	Px [kN]	Py [kN]	Pz [kN]
Kafazi i shkalleve	10.96	-184.22	72.78	6.27	-0.00	0.00	-0.01
Tarraca	7.70	-1178.65	483.53	7.40	-0.00	0.00	0.01
1	3.85	-762.18	255.76	10.21	0.00	0.00	0.00
streha	2.77	0.00	0.00	0.00	0.00	0.00	0.00
0	0.00	-22.03	12.39	5.40	-0.00	0.00	0.00
Themeli	-2.50	-0.00	0.00	4.14	-0.00	0.00	-0.00
	$\Sigma=$	-2147.09	824.47	33.40	-0.00	0.01	-0.00

Level	Z [m]	Mode 9			Mode 10		
		Px [kN]	Py [kN]	Pz [kN]	Px [kN]	Py [kN]	Pz [kN]
Kafazi i shkalleve	10.96	-0.03	0.03	-2.49	-0.00	0.00	0.00
Tarraca	7.70	-0.24	0.37	-1.44	0.00	-0.00	0.00
1	3.85	-0.17	0.25	-0.14	-0.00	-0.00	0.00
streha	2.77	0.00	0.00	0.00	0.00	0.00	0.00
0	0.00	-0.01	0.01	-0.01	-0.00	-0.00	0.00
Themeli	-2.50	-0.00	0.00	-0.01	-0.00	-0.00	0.00
	$\Sigma=$	-0.45	0.65	-4.09	-0.00	-0.00	0.00

Level	Z [m]	Mode 11			Mode 12		
		Px [kN]	Py [kN]	Pz [kN]	Px [kN]	Py [kN]	Pz [kN]
Kafazi i shkalleve	10.96	0.00	-0.00	-0.00	-0.01	-0.00	-0.02
Tarraca	7.70	0.00	-0.00	-0.00	-0.14	0.03	-0.44
1	3.85	0.00	0.00	-0.00	0.24	0.03	-0.04
streha	2.77	0.00	0.00	0.00	0.00	0.00	0.00
0	0.00	0.00	-0.00	-0.00	0.00	0.00	-0.00
Themeli	-2.50	0.00	0.00	-0.00	0.00	0.00	-0.00
	$\Sigma=$	0.00	0.00	-0.00	0.09	0.06	-0.49

Level	Z [m]	Mode 13			Mode 14		
		Px [kN]	Py [kN]	Pz [kN]	Px [kN]	Py [kN]	Pz [kN]
Kafazi i shkalleve	10.96	-0.87	-0.39	-3.31	0.00	0.00	-0.01
Tarraca	7.70	-13.57	2.37	-26.03	0.04	0.00	-0.03
1	3.85	17.61	3.46	-2.19	-0.05	-0.01	-0.00
streha	2.77	0.00	0.00	0.00	0.00	0.00	0.00
0	0.00	0.11	0.18	-0.22	-0.00	-0.00	-0.00
Themeli	-2.50	0.00	0.00	-0.13	-0.00	-0.00	-0.00
	$\Sigma=$	3.28	5.62	-31.87	-0.01	-0.00	-0.04

Level	Z [m]	Mode 15			Mode 16		
		Px [kN]	Py [kN]	Pz [kN]	Px [kN]	Py [kN]	Pz [kN]
Kafazi i shkalleve	10.96	-0.26	-0.17	-1.78	0.04	-0.02	-0.06
Tarraca	7.70	-4.34	-0.24	18.90	0.67	-0.26	5.15
1	3.85	5.61	2.37	0.74	-1.02	0.37	-4.87
streha	2.77	0.00	0.00	0.00	0.00	0.00	0.00
0	0.00	0.07	0.16	0.06	-0.02	-0.00	-0.00
Themeli	-2.50	0.00	0.00	0.00	-0.00	0.00	-0.00
	$\Sigma=$	1.07	2.12	17.93	-0.33	0.09	0.22

Level	Z [m]	Mode 17			Mode 18		
		Px [kN]	Py [kN]	Pz [kN]	Px [kN]	Py [kN]	Pz [kN]
Kafazi i shkalleve	10.96	0.01	0.01	-0.01	0.00	-0.04	-0.22
Tarraca	7.70	0.06	0.01	0.53	-0.13	0.17	-1.42
1	3.85	-0.09	-0.03	2.16	0.07	0.36	-1.73
streha	2.77	0.00	0.00	0.00	0.00	0.00	0.00
0	0.00	0.00	0.01	0.01	0.02	0.01	-0.04
Themeli	-2.50	-0.00	-0.00	0.01	-0.00	0.00	-0.02
	$\Sigma=$	-0.01	0.01	2.70	-0.03	0.51	-3.43

Level	Z [m]	Mode 19			Mode 20		
		Px [kN]	Py [kN]	Pz [kN]	Px [kN]	Py [kN]	Pz [kN]
Kafazi i shkalleve	10.96	-0.02	0.04	-0.16	-0.05	-0.11	0.42
Tarraca	7.70	0.54	-0.02	8.32	-0.07	0.14	2.40
1	3.85	-1.02	0.65	12.41	1.32	1.58	4.58
streha	2.77	0.00	0.00	0.00	0.00	0.00	0.00
0	0.00	-0.10	0.13	0.08	0.12	0.15	-0.04
Themeli	-2.50	-0.00	0.00	0.02	0.00	0.00	-0.05
	$\Sigma=$	-0.60	0.80	20.68	1.32	1.77	7.31

Level	Z [m]	Mode 21			Mode 22		
		Px [kN]	Py [kN]	Pz [kN]	Px [kN]	Py [kN]	Pz [kN]
Kafazi i shkalleve	10.96	-0.03	-0.03	0.05	-0.11	-0.24	-0.20
Tarraca	7.70	0.07	0.06	-0.42	-0.51	0.57	-0.47
1	3.85	-0.00	0.25	0.28	-0.27	2.80	-15.71
streha	2.77	0.00	0.00	0.00	0.00	0.00	0.00
0	0.00	0.00	0.02	-0.01	-0.01	0.18	-0.35
Themeli	-2.50	0.00	0.00	-0.01	-0.00	0.00	-0.24
	$\Sigma=$	0.05	0.31	-0.11	-0.90	3.30	-16.98

Level	Z [m]	Mode 23			Mode 24		
		Px [kN]	Py [kN]	Pz [kN]	Px [kN]	Py [kN]	Pz [kN]
Kafazi i shkalleve	10.96	0.00	-0.29	0.49	0.01	0.00	-0.00
Tarraca	7.70	-1.36	1.31	-15.79	-0.03	-0.00	0.07
1	3.85	-0.96	1.92	-0.43	-0.04	-0.01	-0.00
streha	2.77	0.00	0.00	0.00	0.00	0.00	0.00
0	0.00	-0.16	0.14	-0.25	-0.01	-0.00	0.00
Themeli	-2.50	-0.00	0.00	-0.15	-0.00	-0.00	0.00
	$\Sigma=$	-2.47	3.09	-16.13	-0.07	-0.01	0.07

Level	Z [m]	Mode 25			Mode 26		
		Px [kN]	Py [kN]	Pz [kN]	Px [kN]	Py [kN]	Pz [kN]
Kafazi i shkalleve	10.96	-0.14	-1.28	-0.13	-0.00	0.04	-0.09
Tarraca	7.70	-0.21	-1.25	-12.74	-0.19	0.67	0.45
1	3.85	-0.30	10.34	2.15	-0.24	-0.42	-5.34
streha	2.77	0.00	0.00	0.00	0.00	0.00	0.00
0	0.00	0.04	0.55	-0.29	-0.01	0.04	-0.11
Themeli	-2.50	-0.00	0.00	-0.23	-0.00	0.00	-0.09
	$\Sigma=$	-0.62	8.35	-11.23	-0.45	0.33	-5.18

Level	Z [m]	Mode 27			Mode 28		
		Px [kN]	Py [kN]	Pz [kN]	Px [kN]	Py [kN]	Pz [kN]
Kafazi i shkalleve	10.96	-0.04	-0.14	0.01	-14.96	-74.15	-2.17
Tarraca	7.70	-0.05	-0.61	-0.11	-29.17	-322.09	-97.96
1	3.85	0.31	1.62	-0.06	96.72	863.10	-30.79
streha	2.77	0.00	0.00	0.00	0.00	0.00	0.00
0	0.00	0.02	0.07	-0.01	4.37	37.27	-3.35
Themeli	-2.50	0.00	0.00	-0.01	0.00	0.00	-3.30
	$\Sigma=$	0.24	0.94	-0.18	56.96	504.13	-137.56

Level	Z [m]	Mode 29			Mode 30		
		Px [kN]	Py [kN]	Pz [kN]	Px [kN]	Py [kN]	Pz [kN]
Kafazi i shkalleve	10.96	-0.37	-0.42	-0.10	-0.45	-2.63	-0.38
Tarraca	7.70	-0.31	-1.62	6.63	-0.77	-11.70	48.31
1	3.85	2.68	4.09	0.10	2.43	29.32	6.52
streha	2.77	0.00	0.00	0.00	0.00	0.00	0.00
0	0.00	0.18	0.12	-0.03	-0.04	0.70	0.24
Themeli	-2.50	0.00	0.00	-0.06	0.00	0.00	-0.10
	$\Sigma=$	2.18	2.18	6.53	1.17	15.69	54.58

Distribution of seismic forces along height of structure - SY (-e)

Level	Z [m]	Mode 1			Mode 2		
		Px [kN]	Py [kN]	Pz [kN]	Px [kN]	Py [kN]	Pz [kN]
Kafazi i shkalleve	10.96	-0.04	-0.04	0.00	103.97	302.39	0.83
Tarraca	7.70	-0.93	-0.26	-0.00	570.74	2101.1	24.91
1	3.85	-0.72	-0.20	0.00	286.39	1247.6	6.77
streha	2.77	0.00	0.00	0.00	0.00	0.00	0.00
0	0.00	-0.01	-0.01	0.00	6.67	46.38	0.78
Themeli	-2.50	-0.00	-0.00	0.00	0.00	0.00	-4.27
	$\Sigma=$	-1.69	-0.50	0.01	967.77	3697.4	29.02

Level	Z [m]	Mode 3			Mode 4		
		Px [kN]	Py [kN]	Pz [kN]	Px [kN]	Py [kN]	Pz [kN]
Kafazi i shkalleve	10.96	-0.23	-0.11	0.00	0.07	0.06	-0.00
Tarraca	7.70	-1.48	-0.73	-0.01	0.39	0.41	0.00
1	3.85	-0.86	0.67	0.01	0.24	-0.20	-0.00
streha	2.77	0.00	0.00	0.00	0.00	0.00	0.00
0	0.00	-0.02	-0.01	0.00	0.01	0.01	-0.00
Themeli	-2.50	-0.00	-0.00	0.01	0.00	0.00	-0.00
	$\Sigma=$	-2.59	-0.18	0.01	0.70	0.28	0.00

Level	Z [m]	Mode 5			Mode 6		
		Px [kN]	Py [kN]	Pz [kN]	Px [kN]	Py [kN]	Pz [kN]
Kafazi i shkalleve	10.96	-2.45	-0.35	0.06	-15.77	2.69	0.47
Tarraca	7.70	-15.73	-2.42	-0.01	-99.62	17.38	0.33
1	3.85	-9.61	6.62	0.08	-63.75	31.17	0.72
streha	2.77	0.00	0.00	0.00	0.00	0.00	0.00
0	0.00	-0.27	0.02	0.06	-1.82	0.66	0.42
Themeli	-2.50	-0.00	0.00	0.06	-0.00	0.00	0.36
	$\Sigma=$	-28.06	3.87	0.24	-180.96	51.90	2.30

Level	Z [m]	Mode 7			Mode 8		
		Px [kN]	Py [kN]	Pz [kN]	Px [kN]	Py [kN]	Pz [kN]
Kafazi i shkalleve	10.96	-184.22	72.78	6.27	-0.00	0.00	-0.01
Tarraca	7.70	-1178.65	483.53	7.40	-0.00	0.00	0.01
1	3.85	-762.18	255.76	10.21	0.00	0.00	0.00
streha	2.77	0.00	0.00	0.00	0.00	0.00	0.00
0	0.00	-22.03	12.39	5.40	-0.00	0.00	0.00
Themeli	-2.50	-0.00	0.00	4.14	-0.00	0.00	-0.00
	$\Sigma=$	-2147.09	824.47	33.40	-0.00	0.01	-0.00

Level	Z [m]	Mode 9			Mode 10		
		Px [kN]	Py [kN]	Pz [kN]	Px [kN]	Py [kN]	Pz [kN]
Kafazi i shkalleve	10.96	-0.03	0.03	-2.49	-0.00	0.00	0.00
Tarraca	7.70	-0.24	0.37	-1.44	0.00	-0.00	0.00
1	3.85	-0.17	0.25	-0.14	-0.00	-0.00	0.00
streha	2.77	0.00	0.00	0.00	0.00	0.00	0.00
0	0.00	-0.01	0.01	-0.01	-0.00	-0.00	0.00
Themeli	-2.50	-0.00	0.00	-0.01	-0.00	-0.00	0.00
	$\Sigma=$	-0.45	0.65	-4.09	-0.00	-0.00	0.00

Level	Z [m]	Mode 11			Mode 12		
		Px [kN]	Py [kN]	Pz [kN]	Px [kN]	Py [kN]	Pz [kN]
Kafazi i shkalleve	10.96	0.00	-0.00	-0.00	-0.01	-0.00	-0.02
Tarraca	7.70	0.00	-0.00	-0.00	-0.14	0.03	-0.44
1	3.85	0.00	0.00	-0.00	0.24	0.03	-0.04
streha	2.77	0.00	0.00	0.00	0.00	0.00	0.00
0	0.00	0.00	-0.00	-0.00	0.00	0.00	-0.00
Themeli	-2.50	0.00	0.00	-0.00	0.00	0.00	-0.00
	$\Sigma=$	0.00	0.00	-0.00	0.09	0.06	-0.49

Level	Z [m]	Mode 13			Mode 14		
		Px [kN]	Py [kN]	Pz [kN]	Px [kN]	Py [kN]	Pz [kN]
Kafazi i shkalleve	10.96	-0.87	-0.39	-3.31	0.00	0.00	-0.01
Tarraca	7.70	-13.57	2.37	-26.03	0.04	0.00	-0.03
1	3.85	17.61	3.46	-2.19	-0.05	-0.01	-0.00
streha	2.77	0.00	0.00	0.00	0.00	0.00	0.00
0	0.00	0.11	0.18	-0.22	-0.00	-0.00	-0.00
Themeli	-2.50	0.00	0.00	-0.13	-0.00	-0.00	-0.00
	$\Sigma=$	3.28	5.62	-31.87	-0.01	-0.00	-0.04

Level	Z [m]	Mode 15			Mode 16		
		Px [kN]	Py [kN]	Pz [kN]	Px [kN]	Py [kN]	Pz [kN]
Kafazi i shkalleve	10.96	-0.26	-0.17	-1.78	0.04	-0.02	-0.06
Tarraca	7.70	-4.34	-0.24	18.90	0.67	-0.26	5.15
1	3.85	5.61	2.37	0.74	-1.02	0.37	-4.87
streha	2.77	0.00	0.00	0.00	0.00	0.00	0.00
0	0.00	0.07	0.16	0.06	-0.02	-0.00	-0.00
Themeli	-2.50	0.00	0.00	0.00	-0.00	0.00	-0.00
	$\Sigma=$	1.07	2.12	17.93	-0.33	0.09	0.22

Level	Z [m]	Mode 17			Mode 18		
		Px [kN]	Py [kN]	Pz [kN]	Px [kN]	Py [kN]	Pz [kN]
Kafazi i shkalleve	10.96	0.01	0.01	-0.01	0.00	-0.04	-0.22
Tarraca	7.70	0.06	0.01	0.53	-0.13	0.17	-1.42
1	3.85	-0.09	-0.03	2.16	0.07	0.36	-1.73
streha	2.77	0.00	0.00	0.00	0.00	0.00	0.00
0	0.00	0.00	0.01	0.01	0.02	0.01	-0.04
Themeli	-2.50	-0.00	-0.00	0.01	-0.00	0.00	-0.02
	$\Sigma=$	-0.01	0.01	2.70	-0.03	0.51	-3.43

Level	Z [m]	Mode 19			Mode 20		
		Px [kN]	Py [kN]	Pz [kN]	Px [kN]	Py [kN]	Pz [kN]
Kafazi i shkalleve	10.96	-0.02	0.04	-0.16	-0.05	-0.11	0.42
Tarraca	7.70	0.54	-0.02	8.32	-0.07	0.14	2.40
1	3.85	-1.02	0.65	12.41	1.32	1.58	4.58
streha	2.77	0.00	0.00	0.00	0.00	0.00	0.00
0	0.00	-0.10	0.13	0.08	0.12	0.15	-0.04
Themeli	-2.50	-0.00	0.00	0.02	0.00	0.00	-0.05
	$\Sigma=$	-0.60	0.80	20.68	1.32	1.77	7.31

Level	Z [m]	Mode 21			Mode 22		
		Px [kN]	Py [kN]	Pz [kN]	Px [kN]	Py [kN]	Pz [kN]
Kafazi i shkalleve	10.96	-0.03	-0.03	0.05	-0.11	-0.24	-0.20
Tarraca	7.70	0.07	0.06	-0.42	-0.51	0.57	-0.47
1	3.85	-0.00	0.25	0.28	-0.27	2.80	-15.71
streha	2.77	0.00	0.00	0.00	0.00	0.00	0.00
0	0.00	0.00	0.02	-0.01	-0.01	0.18	-0.35
Themeli	-2.50	0.00	0.00	-0.01	-0.00	0.00	-0.24
	$\Sigma=$	0.05	0.31	-0.11	-0.90	3.30	-16.98

Level	Z [m]	Mode 23			Mode 24		
		Px [kN]	Py [kN]	Pz [kN]	Px [kN]	Py [kN]	Pz [kN]
Kafazi i shkalleve	10.96	0.00	-0.29	0.49	0.01	0.00	-0.00
Tarraca	7.70	-1.36	1.31	-15.79	-0.03	-0.00	0.07
1	3.85	-0.96	1.92	-0.43	-0.04	-0.01	-0.00
streha	2.77	0.00	0.00	0.00	0.00	0.00	0.00
0	0.00	-0.16	0.14	-0.25	-0.01	-0.00	0.00
Themeli	-2.50	-0.00	0.00	-0.15	-0.00	-0.00	0.00
	$\Sigma=$	-2.47	3.09	-16.13	-0.07	-0.01	0.07

Level	Z [m]	Mode 25			Mode 26		
		Px [kN]	Py [kN]	Pz [kN]	Px [kN]	Py [kN]	Pz [kN]
Kafazi i shkalleve	10.96	-0.14	-1.28	-0.13	-0.00	0.04	-0.09
Tarraca	7.70	-0.21	-1.25	-12.74	-0.19	0.67	0.45
1	3.85	-0.30	10.34	2.15	-0.24	-0.42	-5.34
streha	2.77	0.00	0.00	0.00	0.00	0.00	0.00
0	0.00	0.04	0.55	-0.29	-0.01	0.04	-0.11
Themeli	-2.50	-0.00	0.00	-0.23	-0.00	0.00	-0.09
	$\Sigma=$	-0.62	8.35	-11.23	-0.45	0.33	-5.18

Level	Z [m]	Mode 27			Mode 28		
		Px [kN]	Py [kN]	Pz [kN]	Px [kN]	Py [kN]	Pz [kN]
Kafazi i shkalleve	10.96	-0.04	-0.14	0.01	-14.96	-74.15	-2.17
Tarraca	7.70	-0.05	-0.61	-0.11	-29.17	-322.09	-97.96
1	3.85	0.31	1.62	-0.06	96.72	863.10	-30.79
streha	2.77	0.00	0.00	0.00	0.00	0.00	0.00
0	0.00	0.02	0.07	-0.01	4.37	37.27	-3.35
Themeli	-2.50	0.00	0.00	-0.01	0.00	0.00	-3.30
	$\Sigma=$	0.24	0.94	-0.18	56.96	504.13	-137.56

Level	Z [m]	Mode 29			Mode 30		
		Px [kN]	Py [kN]	Pz [kN]	Px [kN]	Py [kN]	Pz [kN]
Kafazi i shkalleve	10.96	-0.37	-0.42	-0.10	-0.45	-2.63	-0.38
Tarraca	7.70	-0.31	-1.62	6.63	-0.77	-11.70	48.31
1	3.85	2.68	4.09	0.10	2.43	29.32	6.52
streha	2.77	0.00	0.00	0.00	0.00	0.00	0.00
0	0.00	0.18	0.12	-0.03	-0.04	0.70	0.24
Themeli	-2.50	0.00	0.00	-0.06	0.00	0.00	-0.10
	$\Sigma=$	2.18	2.18	6.53	1.17	15.69	54.58

Distribution factors - relative share

Mode \ Name	1. SX (+e)	2. SX (-e)	3. SY (+e)	4. SY (-e)
1	0.195	0.195	0.000	0.000
2	0.244	0.244	0.616	0.616
3	0.002	0.002	0.000	0.000
4	0.002	0.002	0.000	0.000
5	0.011	0.011	0.002	0.002
6	0.050	0.050	0.019	0.019
7	0.473	0.473	0.266	0.266
8	0.000	0.000	0.000	0.000
9	0.000	0.000	0.000	0.000
10	0.000	0.000	0.000	0.000
11	0.000	0.000	0.000	0.000
12	0.000	0.000	0.000	0.000
13	0.001	0.001	0.001	0.001
14	0.002	0.002	0.000	0.000
15	0.000	0.000	0.000	0.000
16	0.000	0.000	0.000	0.000
17	0.000	0.000	0.000	0.000
18	0.000	0.000	0.000	0.000
19	0.000	0.000	0.000	0.000
20	0.000	0.000	0.000	0.000
21	0.000	0.000	0.000	0.000
22	0.000	0.000	0.001	0.001
23	0.000	0.000	0.001	0.001
24	0.000	0.000	0.000	0.000
25	0.000	0.000	0.002	0.002
26	0.000	0.000	0.000	0.000
27	0.000	0.000	0.000	0.000
28	0.017	0.017	0.088	0.088
29	0.001	0.001	0.000	0.000
30	0.000	0.000	0.003	0.003

Distribution factors - mass involvement

Mode	U [$\alpha=0^\circ$]	U [$\alpha=90^\circ$]	U [Z]
1	9.48	0.84	0.00
2	3.06	44.61	0.00
3	0.13	0.00	0.00
4	0.08	0.01	0.00
5	0.72	0.01	0.00
6	3.47	0.29	0.00
7	35.31	5.21	0.01
8	0.00	0.00	0.00
9	0.00	0.01	0.24
10	0.00	0.00	0.00
11	0.00	0.00	0.00
12	0.00	0.00	0.10
13	0.03	0.08	2.53
14	0.11	0.01	0.89
15	0.01	0.03	2.07
16	0.01	0.00	0.00
17	0.00	0.00	7.84
18	0.00	0.01	0.26
19	0.00	0.01	5.07
20	0.01	0.03	0.45
21	0.00	0.00	0.00
22	0.00	0.04	0.94
23	0.02	0.03	0.79
24	0.01	0.00	0.01
25	0.00	0.10	0.17
26	0.01	0.00	0.67

Distribution factors - mass involvement

Mode	U [$\alpha=0^\circ$]	U [$\alpha=90^\circ$]	U [Z]
27	0.00	0.01	0.00
28	0.08	6.12	0.46
29	0.04	0.04	0.33
30	0.00	0.19	2.28
ΣU (%)	52.56	57.66	25.14

Structural analysis

Load 11: 1.35xI+1.5xII+1.5xIII+0.9xIV

Mx [kNm/m]
-203.27
-162.62
-121.96
-81.31
-40.65
0.00
42.81
85.61

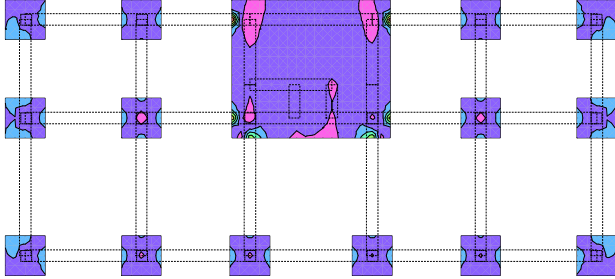

Level: Themeli [-2.50 m]
Slab Results: Mx

Load 11: 1.35xI+1.5xII+1.5xIII+0.9xIV

My [kNm/m]
-195.04
-156.03
-117.02
-78.02
-39.01
0.00
30.34
60.68

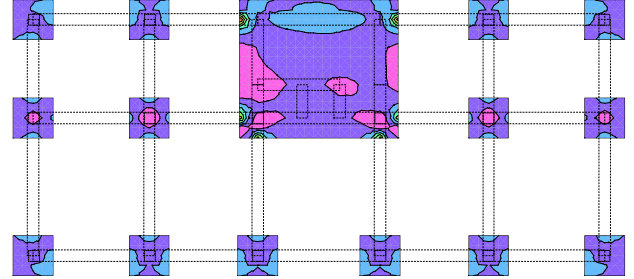

Level: Themeli [-2.50 m]
Slab Results: My

Load 11: 1.35xI+1.5xII+1.5xIII+0.9xIV

Mxy [kNm/m]
-55.30
-36.87
-18.43
0.00
14.49
28.98
43.47
57.96

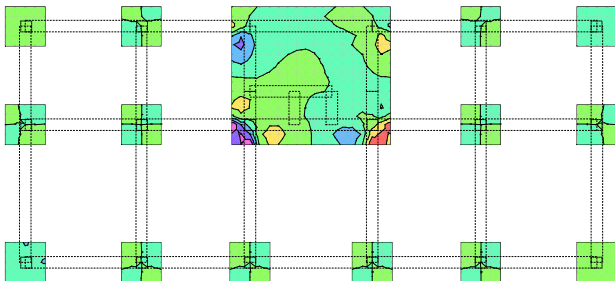

Level: Themeli [-2.50 m]
Slab Results: Mxy

Load 11: 1.35xI+1.5xII+1.5xIII+0.9xIV

Mx [kNm/m]
-31.82
-23.87
-15.91
-7.96
0.00
6.62
13.25
19.87

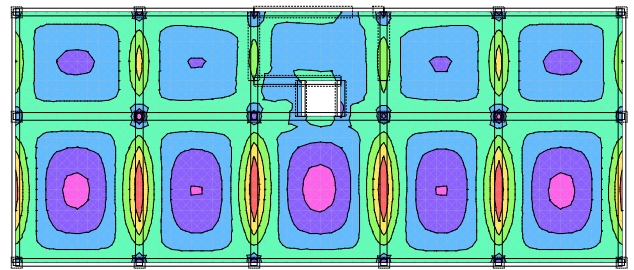

Level: 0 [0.00 m]
Slab Results: Mx

Load 11: 1.35xI+1.5xII+1.5xIII+0.9xIV

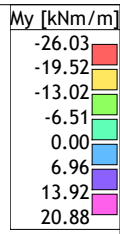

Load 11: 1.35xI+1.5xII+1.5xIII+0.9xIV

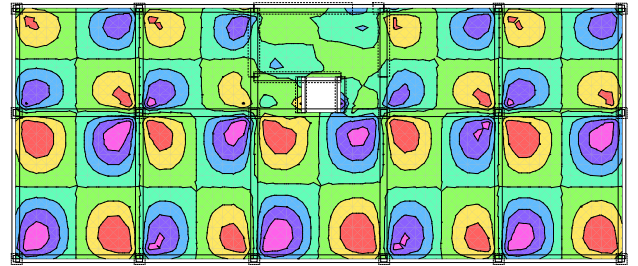
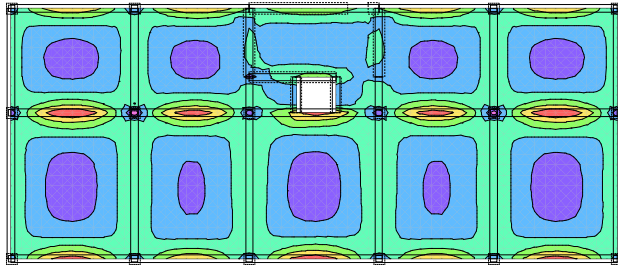
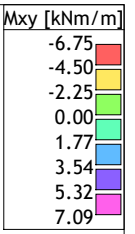

Level: 0 [0.00 m]
Slab Results: My

Level: 0 [0.00 m]
Slab Results: Mxy

Load 11: 1.35xI+1.5xII+1.5xIII+0.9xIV

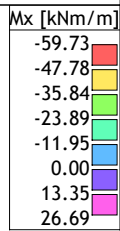

Load 11: 1.35xI+1.5xII+1.5xIII+0.9xIV

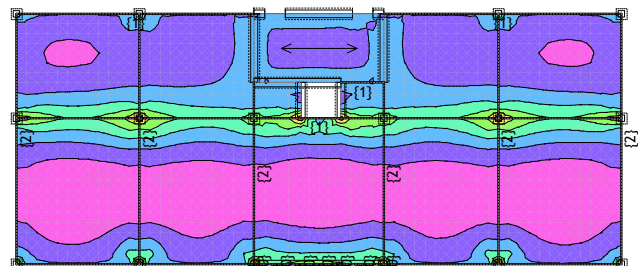
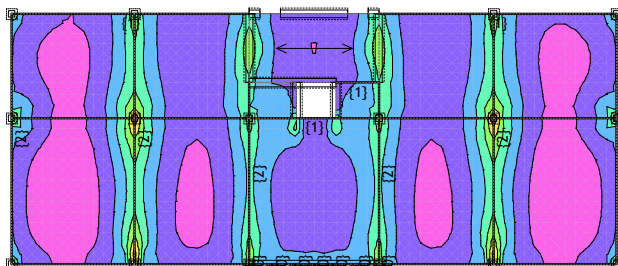
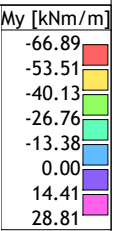

Level: 1 [3.85 m]
Slab Results: Mx

Level: 1 [3.85 m]
Slab Results: My

Load 11: 1.35xI+1.5xII+1.5xIII+0.9xIV

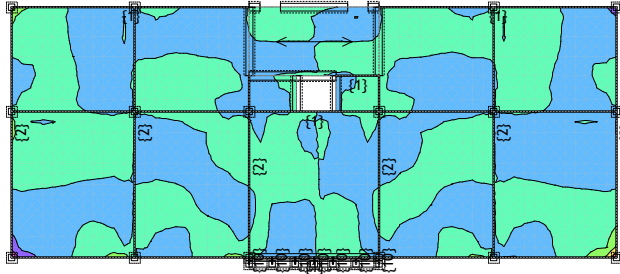
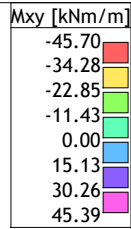

Level: 1 [3.85 m]
Slab Results: Mxy

Load 11: 1.35xI+1.5xII+1.5xIII+0.9xIV

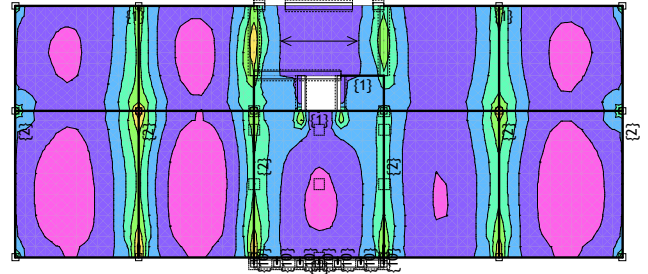
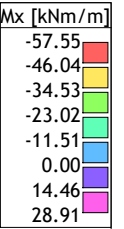

Level: Tarraca [7.70 m]
Slab Results: Mx

Load 11: 1.35xI+1.5xII+1.5xIII+0.9xIV

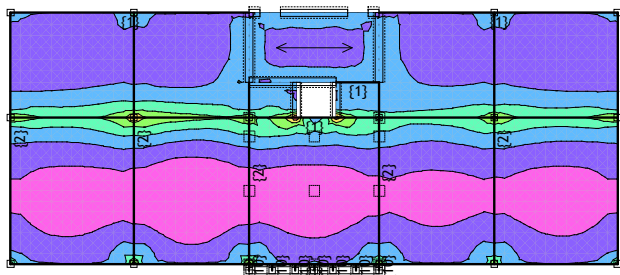
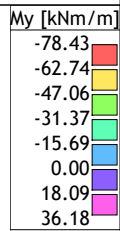

Level: Tarraca [7.70 m]
Slab Results: My

Load 11: 1.35xI+1.5xII+1.5xIII+0.9xIV

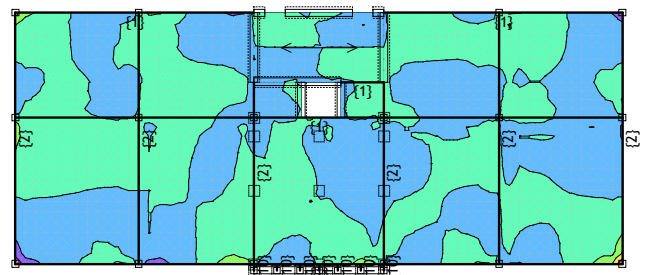
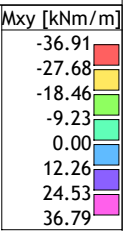

Level: Tarraca [7.70 m]
Slab Results: Mxy

General parameters for EC8 (Capacity Design)

EC 2 (EN 1992-1-1:2004)

Ductility class DCM

Non-structural elements of brittle materials attached to the structure

Interstorey drift sensitivity coefficient - 5. SX (+e) (0°)

Level	Z[m]	Height[m]	Weight[kN]	Seis.For.[kN]	Δs[mm]	θ
Kafazi i shkalleve	10.96	3.26	651.18	292.47	4.92	0.003
Tarraca	7.70	3.85	6618.88	2209.83	4.69	0.004
1	3.85	3.85	13783.06	3452.29	6.10	0.006
0	0.00	2.50	20726.35	3485.71	0.14	0.000

Frames or frame-equivalent dual systems

Ductility condition (4.29): $\Sigma M_{Rc} \geq 1.300 \times \Sigma M_{Rb}$

Behavior factor = 3.45

Max. interstorey drift sensitivity coefficient $\theta = 0.006$ (1, Z = 3.85 m)

Second-order effects need not be taken into account.

Interstorey drift sensitivity coefficient - 6. SX (-e) (0°)

Level	Z[m]	Height[m]	Weight[kN]	Seis.For.[kN]	Δs[mm]	θ
Kafazi i shkalleve	10.96	3.26	651.18	292.47	5.36	0.004
Tarraca	7.70	3.85	6618.88	2209.83	4.45	0.003
1	3.85	3.85	13783.06	3452.29	5.61	0.006
0	0.00	2.50	20726.35	3485.71	0.13	0.000

Frames or frame-equivalent dual systems

Ductility condition (4.29): $\Sigma M_{Rc} \geq 1.300 \times \Sigma M_{Rb}$

Behavior factor = 3.45

Max. interstorey drift sensitivity coefficient $\theta = 0.006$ (1, Z = 3.85 m)

Second-order effects need not be taken into account.

Interstorey drift sensitivity coefficient - 7. SY (+e) (90°)

Level	Z[m]	Height[m]	Weight[kN]	Seis.For.[kN]	Δs[mm]	θ
Kafazi i shkalleve	10.96	3.26	651.18	336.33	4.56	0.003
Tarraca	7.70	3.85	6618.88	2624.78	6.87	0.004
1	3.85	3.85	13783.06	3976.88	6.55	0.006
0	0.00	2.50	20726.35	4032.68	0.26	0.001

Frames or frame-equivalent dual systems

Ductility condition (4.29): $\Sigma M_{Rc} \geq 1.300 \times \Sigma M_{Rb}$

Behavior factor = 3.45

Max. interstorey drift sensitivity coefficient $\theta = 0.006$ (1, Z = 3.85 m)

Second-order effects need not be taken into account.

Interstorey drift sensitivity coefficient - 8. SY (-e) (90°)

Level	Z[m]	Height[m]	Weight[kN]	Seis.For.[kN]	Δs[mm]	θ
Kafazi i shkalleve	10.96	3.26	651.18	336.33	4.19	0.002
Tarraca	7.70	3.85	6618.88	2624.78	6.89	0.005
1	3.85	3.85	13783.06	3976.88	6.31	0.006
0	0.00	2.50	20726.35	4032.68	0.26	0.001

Frames or frame-equivalent dual systems

Ductility condition (4.29): $\Sigma M_{Rc} \geq 1.300 \times \Sigma M_{Rb}$

Behavior factor = 3.45

Max. interstorey drift sensitivity coefficient $\theta = 0.006$ (1, Z = 3.85 m)

Second-order effects need not be taken into account.

Interstorey drifts - 9. SRSS: MAX(V,VI)+MAX(VII,VIII)

Level	Z[m]	Height[m]	$d_r(0^\circ)$ [mm]	$d_r(90^\circ)$ [mm]	$d_{r,max}$ [mm]	d_{lim} [mm]
Kafazi i shkalleve	10.96	3.26	5.36	4.56	5.36	40.75
Tarraca	7.70	3.85	4.69	6.89	6.89	48.12
1	3.85	3.85	6.10	6.55	6.55	48.12
0	0.00	2.50	0.14	0.26	0.26	31.25

Conditions for limiting interstorey drifts are fulfilled.

Geometrical constrains for beams 5.4.1.2.1 - (2) [eccentricity limitation at the joint]

The criteria is satisfied.

Geometrical constrains for beams 5.4.1.2.1 - (3) [width limitation at the joint]

The criteria is satisfied.

Geometrical constrains for beams 5.4.1.2.5 - (2a) [eccentricity]

The criteria is satisfied.

Geometrical constrains for beams 5.4.1.2.5 - (2b) [number of supports]

The criteria is satisfied.

General parameters for EC8 (Capacity Design)

EC 2 (EN 1992-1-1:2004)
Ductility class DCM
Ductile non-structural elements

Interstorey drift sensitivity coefficient - 5. SX (+e) (0°)

Level	Z[m]	Height[m]	Weight[kN]	Seis.For.[kN]	Δs[mm]	θ
Kafazi i shkalleve	10.96	3.26	651.18	292.47	4.92	0.003
Tarraca	7.70	3.85	6618.88	2209.83	4.69	0.004
1	3.85	3.85	13783.06	3452.29	6.10	0.006
0	0.00	2.50	20726.35	3485.71	0.14	0.000

Frames or frame-equivalent dual systems

Ductility condition (4.29): $\Sigma M_{Rc} \geq 1.300 \times \Sigma M_{Rb}$

Behavior factor = 3.45

Max. interstorey drift sensitivity coefficient $\theta = 0.006$ (1, Z = 3.85 m)

Second-order effects need not be taken into account.

Interstorey drift sensitivity coefficient - 6. SX (-e) (0°)

Level	Z[m]	Height[m]	Weight[kN]	Seis.For.[kN]	Δs[mm]	θ
Kafazi i shkalleve	10.96	3.26	651.18	292.47	5.36	0.004
Tarraca	7.70	3.85	6618.88	2209.83	4.45	0.003
1	3.85	3.85	13783.06	3452.29	5.61	0.006
0	0.00	2.50	20726.35	3485.71	0.13	0.000

Frames or frame-equivalent dual systems

Ductility condition (4.29): $\Sigma M_{Rc} \geq 1.300 \times \Sigma M_{Rb}$

Behavior factor = 3.45

Max. interstorey drift sensitivity coefficient $\theta = 0.006$ (1, Z = 3.85 m)

Second-order effects need not be taken into account.

Interstorey drift sensitivity coefficient - 7. SY (+e) (90°)

Level	Z[m]	Height[m]	Weight[kN]	Seis.For.[kN]	Δs[mm]	θ
Kafazi i shkalleve	10.96	3.26	651.18	336.33	4.56	0.003
Tarraca	7.70	3.85	6618.88	2624.78	6.87	0.004
1	3.85	3.85	13783.06	3976.88	6.55	0.006
0	0.00	2.50	20726.35	4032.68	0.26	0.001

Frames or frame-equivalent dual systems

Ductility condition (4.29): $\Sigma M_{Rc} \geq 1.300 \times \Sigma M_{Rb}$

Behavior factor = 3.45

Max. interstorey drift sensitivity coefficient $\theta = 0.006$ (1, Z = 3.85 m)

Second-order effects need not be taken into account.

Interstorey drift sensitivity coefficient - 8. SY (-e) (90°)

Level	Z[m]	Height[m]	Weight[kN]	Seis.For.[kN]	Δs[mm]	θ
Kafazi i shkalleve	10.96	3.26	651.18	336.33	4.19	0.002
Tarraca	7.70	3.85	6618.88	2624.78	6.89	0.005
1	3.85	3.85	13783.06	3976.88	6.31	0.006
0	0.00	2.50	20726.35	4032.68	0.26	0.001

Frames or frame-equivalent dual systems

Ductility condition (4.29): $\Sigma M_{Rc} \geq 1.300 \times \Sigma M_{Rb}$

Behavior factor = 3.45

Max. interstorey drift sensitivity coefficient $\theta = 0.006$ (1, Z = 3.85 m)

Second-order effects need not be taken into account.

Interstorey drifts - 9. SRSS: MAX(V,VI)+MAX(VII,VIII)

Level	Z[m]	Height[m]	$d_r(0^\circ)$ [mm]	$d_r(90^\circ)$ [mm]	$d_{r,max}$ [mm]	d_{lim} [mm]
Kafazi i shkalleve	10.96	3.26	5.36	4.56	5.36	61.13
Tarraca	7.70	3.85	4.69	6.89	6.89	72.19
1	3.85	3.85	6.10	6.55	6.55	72.19
0	0.00	2.50	0.14	0.26	0.26	46.88

Conditions for limiting interstorey drifts are fulfilled.

Geometrical constrains for beams 5.4.1.2.1 - (2) [eccentricity limitation at the joint]

The criteria is satisfied.

Geometrical constrains for beams 5.4.1.2.1 - (3) [width limitation at the joint]

The criteria is satisfied.

Geometrical constrains for beams 5.4.1.2.5 - (2a) [eccentricity]

The criteria is satisfied.

Geometrical constrains for beams 5.4.1.2.5 - (2b) [number of supports]
The criteria is satisfied.

General parameters for EC8 (Capacity Design)

EC 2 (EN 1992-1-1:2004)

Ductility class DCM

Non-structural elements fixed in a way so as not to interfere with structural deformations

Interstorey drift sensitivity coefficient - 5. SX (+e) (0°)

Level	Z[m]	Height[m]	Weight[kN]	Seis.For.[kN]	Δs[mm]	θ
Kafazi i shkalleve	10.96	3.26	651.18	292.47	4.92	0.003
Tarraca	7.70	3.85	6618.88	2209.83	4.69	0.004
1	3.85	3.85	13783.06	3452.29	6.10	0.006
0	0.00	2.50	20726.35	3485.71	0.14	0.000

Frames or frame-equivalent dual systems

Ductility condition (4.29): $\Sigma M_{Rc} \geq 1.300 \times \Sigma M_{Rb}$

Behavior factor = 3.45

Max. interstorey drift sensitivity coefficient $\theta = 0.006$ (1, Z = 3.85 m)

Second-order effects need not be taken into account.

Interstorey drift sensitivity coefficient - 6. SX (-e) (0°)

Level	Z[m]	Height[m]	Weight[kN]	Seis.For.[kN]	Δs[mm]	θ
Kafazi i shkalleve	10.96	3.26	651.18	292.47	5.36	0.004
Tarraca	7.70	3.85	6618.88	2209.83	4.45	0.003
1	3.85	3.85	13783.06	3452.29	5.61	0.006
0	0.00	2.50	20726.35	3485.71	0.13	0.000

Frames or frame-equivalent dual systems

Ductility condition (4.29): $\Sigma M_{Rc} \geq 1.300 \times \Sigma M_{Rb}$

Behavior factor = 3.45

Max. interstorey drift sensitivity coefficient $\theta = 0.006$ (1, Z = 3.85 m)

Second-order effects need not be taken into account.

Interstorey drift sensitivity coefficient - 7. SY (+e) (90°)

Level	Z[m]	Height[m]	Weight[kN]	Seis.For.[kN]	Δs[mm]	θ
Kafazi i shkalleve	10.96	3.26	651.18	336.33	4.56	0.003
Tarraca	7.70	3.85	6618.88	2624.78	6.87	0.004
1	3.85	3.85	13783.06	3976.88	6.55	0.006
0	0.00	2.50	20726.35	4032.68	0.26	0.001

Frames or frame-equivalent dual systems

Ductility condition (4.29): $\Sigma M_{Rc} \geq 1.300 \times \Sigma M_{Rb}$

Behavior factor = 3.45

Max. interstorey drift sensitivity coefficient $\theta = 0.006$ (1, Z = 3.85 m)

Second-order effects need not be taken into account.

Interstorey drift sensitivity coefficient - 8. SY (-e) (90°)

Level	Z[m]	Height[m]	Weight[kN]	Seis.For.[kN]	Δs[mm]	θ
Kafazi i shkalleve	10.96	3.26	651.18	336.33	4.19	0.002
Tarraca	7.70	3.85	6618.88	2624.78	6.89	0.005
1	3.85	3.85	13783.06	3976.88	6.31	0.006
0	0.00	2.50	20726.35	4032.68	0.26	0.001

Frames or frame-equivalent dual systems

Ductility condition (4.29): $\Sigma M_{Rc} \geq 1.300 \times \Sigma M_{Rb}$

Behavior factor = 3.45

Max. interstorey drift sensitivity coefficient $\theta = 0.006$ (1, Z = 3.85 m)

Second-order effects need not be taken into account.

Interstorey drifts - 9. SRSS: MAX(V,VI)+MAX(VII,VIII)

Level	Z[m]	Height[m]	d _r (0°)[mm]	d _r (90°)[mm]	d _{r,max} [mm]	d _{lim} [mm]
Kafazi i shkalleve	10.96	3.26	5.36	4.56	5.36	81.50
Tarraca	7.70	3.85	4.69	6.89	6.89	96.25
1	3.85	3.85	6.10	6.55	6.55	96.25
0	0.00	2.50	0.14	0.26	0.26	62.50

Conditions for limiting interstorey drifts are fulfilled.

Geometrical constrains for beams 5.4.1.2.1 - (2) [eccentricity limitation at the joint]

The criteria is satisfied.

Geometrical constrains for beams 5.4.1.2.1 - (3) [width limitation at the joint]

The criteria is satisfied.

Geometrical constrains for beams 5.4.1.2.5 - (2a) [eccentricity]

The criteria is satisfied.

Geometrical constrains for beams 5.4.1.2.5 - (2b) [number of supports]
The criteria is satisfied.

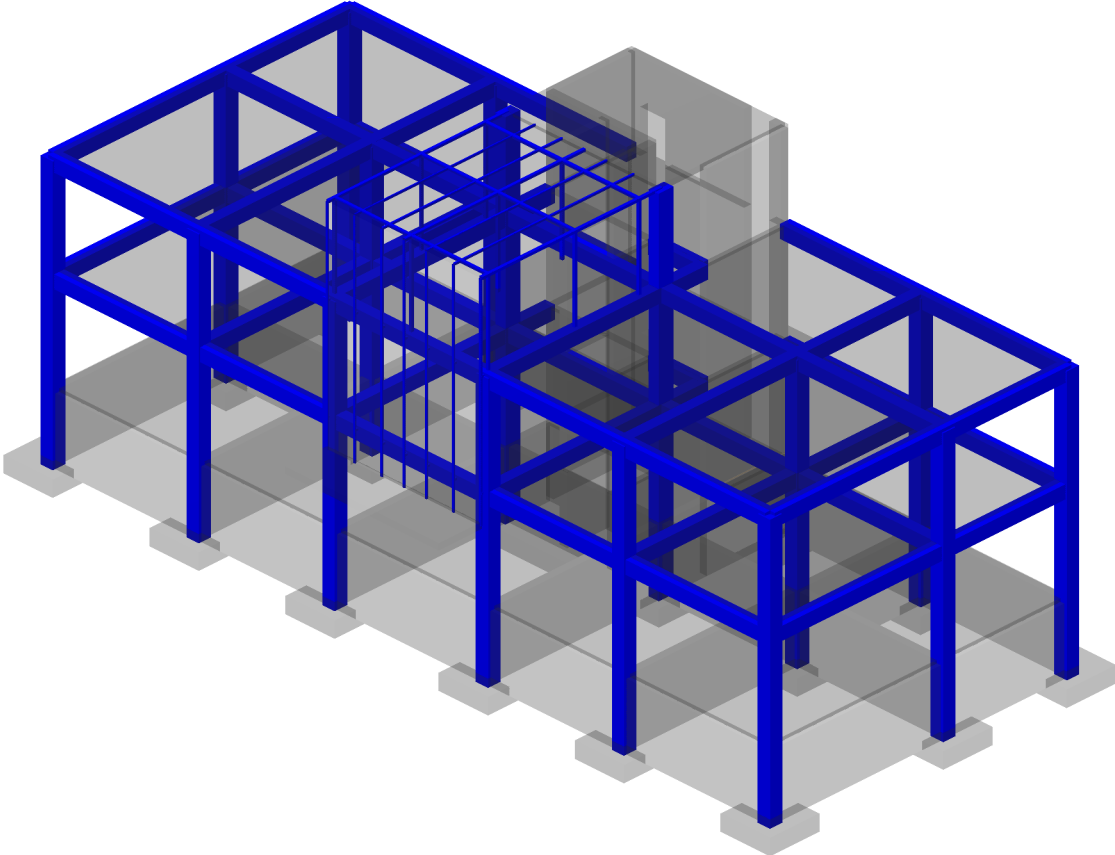

Isometric
Beam reinforcement: Aa2/Aa1

BEAM 2573-3484

CROSS-SECTION: HOP [] 100x100x8 [S 275] [Set: 8]
EUROCODE 3 (ENV)

CROSS-SECTION PROPERTIES

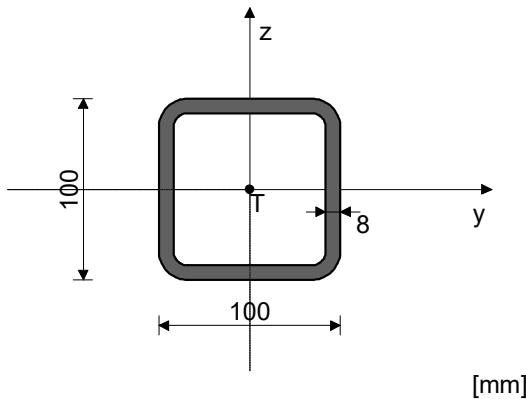

Ax =	27.790 cm ²
Ay =	13.895 cm ²
Az =	13.895 cm ²
Ix =	640.76 cm ⁴
Iy =	379.76 cm ⁴
Iz =	379.76 cm ⁴
Wy =	75.952 cm ³
Wz =	75.952 cm ³
Wy,pl =	101.82 cm ³
Wz,pl =	101.82 cm ³
γM0 =	1.100
γM1 =	1.100
γM2 =	1.250
A _{net} /A =	0.900

[mm]

(f_y = 27.5 kN/cm², f_u = 43.0 kN/cm²)

UTILISATION FACTORS FOR ALL LOAD CASE COMBINATIONS

17. γ=0.16	30. γ=0.15	21. γ=0.15
11. γ=0.14	19. γ=0.13	23. γ=0.13
14. γ=0.13	33. γ=0.12	25. γ=0.12
13. γ=0.11	29. γ=0.11	10. γ=0.11
27. γ=0.10	34. γ=0.10	20. γ=0.10
15. γ=0.10	22. γ=0.09	32. γ=0.09
12. γ=0.09	16. γ=0.08	35. γ=0.08
24. γ=0.08	28. γ=0.07	26. γ=0.07
18. γ=0.05	31. γ=0.04	

MEMBER SUBJECT TO AXIAL COMPRESSION AND BENDING
(load 17, at the beginning of the member)

The axial force design value	N _{sd} =	-9.183 kN
The shear force design value(y-y)	V _{sd_y} =	0.933 kN
The shear force design value(z-z)	V _{sd_z} =	0.961 kN
The bending mom.design value(y-y)	M _{sd_y} =	1.475 kNm
The bending mom.design value(z-z)	M _{sd_z} =	2.074 kNm
System length	L =	326.00 cm

5.3 CLASSIFICATION OF CROSS-SECTIONS

Class 1 cross-sections

5.4 RESISTANCE OF CROSS-SECTIONS

5.4.4 Compression

The design plastic resistance	N _{pl.Rd} =	694.75 kN
The design compression resistance	N _{c.Rd} =	694.75 kN

Requirement 5.16: N_{sd} ≤ N_{c.Rd} (9.18 ≤ 694.75)

5.4.5 Bending about the y-y axis

The design plastic resistance	M _{pl.Rd} =	25.456 kNm
The design local buck. resist.	M _{o.Rd} =	18.988 kNm
The design el.resist.moment	M _{el.Rd} =	18.988 kNm
The design moment resistance	M _{c.Rd} =	25.456 kNm

Requirement 5.17: M_{sd_y} ≤ M_{c.Rd_y} (1.48 ≤ 25.46)

5.4.5 Bending about the z-z axis

The design plastic resistance	M _{pl.Rd} =	25.456 kNm
The design local buck. resist.	M _{o.Rd} =	18.988 kNm
The design el.resist.moment	M _{el.Rd} =	18.988 kNm
The design moment resistance	M _{c.Rd} =	25.456 kNm

Requirement 5.17: M_{sd_z} ≤ M_{c.Rd_z} (2.07 ≤ 25.46)

5.4.6 Shear

The design pl.shear resist.(z-z)	V _{pl.Rd} =	200.56 kN
----------------------------------	----------------------	-----------

Requirement 5.20: V_{sd_z} ≤ V_{pl.Rd_z} (0.96 ≤ 200.56)

The design pl.shear resist.(y-y) $V_{pl,Rd} = 200.56$ kN
Requirement 5.20: $V_{sd,y} \leq V_{pl,Rd,y}$ (0.93 \leq 200.56)

5.4.9 Bending, shear and axial force
 No reduction need be made in the resistance moment
 Requirement: $V_{sd,z} \leq 50\%V_{pl,Rd,z}$ i $V_{sd,y} \leq 50\%V_{pl,Rd,y}$

5.4.8 Bending and axial force
 Ratio $N_{sd} / N_{pl,Rd}$ 0.013
 Ratio $M_{sd,y} / M_{pl,Rd,y}$ 0.058
 Ratio $M_{sd,z} / M_{pl,Rd,z}$ 0.081
Requirement 5.36: (0.15 \leq 1)

5.5. BUCKLING RESISTANCE OF MEMBERS

5.5.1.1 Buckling resistance
 Buckling length y-y $I_{y,y} = 326.00$ cm
 Radius of gyration y-y $i_{y,y} = 3.697$ cm
 Slenderness y-y $\lambda_{y,y} = 88.188$
 Relative slenderness y-y $\lambda_{y,y} = 1.016$
 Buckling curve for axis y-y: B $\alpha = 0.340$
 The reduction factor $\chi_{y,y} = 0.587$
 The effective area factor $\beta_A = 1.000$
 The design buckling resistance $N_{b,Rd,y} = 407.77$ kN
Requirement 5.45: $N_{sd} \leq N_{b,Rd,y}$ (9.18 \leq 407.77)

Buckling length z-z $I_{z,z} = 326.00$ cm
 Radius of gyration z-z $i_{z,z} = 3.697$ cm
 Slenderness z-z $\lambda_{z,z} = 88.188$
 Relative slenderness z-z $\lambda_{z,z} = 1.016$
 Buckling curve for axis z-z: B $\alpha = 0.340$
 The reduction factor $\chi_{z,z} = 0.587$
 The effective area factor $\beta_A = 1.000$
 The design buckling resistance $N_{b,Rd,z} = 407.77$ kN
Requirement 5.45: $N_{sd} \leq N_{b,Rd,z}$ (9.18 \leq 407.77)

5.5.2 Lateral-torsional buckling of beams
 Coefficient $C_1 = 2.829$
 Coefficient $C_2 = 0.000$
 Coefficient $C_3 = 0.162$
 The eff.length fact.for later.restr. $k = 1.000$
 The eff.length fact.for tors.restr. $k_w = 1.000$
 Coordinate $z_g = 0.000$ cm
 Coordinate $z_j = 0.000$ cm
 Length between lateral restr.points $L = 326.00$ cm
 The warping constant $I_w = 0.000$ cm⁶
 The elast.crit.mom.(l-t buck.) $M_{cr} = 1751.7$ kNm
 Coefficient $\beta_w = 1.000$
 The imperfection factor $\alpha_{LT} = 0.210$
 The non-dimensional slenderness $\lambda_{LT} = 0.126$
 The reduction factor $\chi_{LT} = 1.000$
 The design buckling resistance $M_{b,Rd} = 25.456$ kNm
 No allowance for l-t buckling is necessary $\lambda_{LT} \leq 0.4$

5.5.4 Bending and axial compression
 The reduction factor $\chi_{min} = 0.587$
 N_{sd} / \dots 0.023
 The equiv.unif.mom.fact.flex.buck. $\beta_y = 2.423$
 Coefficient $\mu_y = 0.900$
 Coefficient $k_y = 0.982$
 $k_y * M_y / \dots$ 0.057
 The equiv.unif.mom.fact.flex.buck. $\beta_z = 2.127$
 Coefficient $\mu_z = 0.598$
 Coefficient $k_z = 0.988$
 $k_z * M_z / \dots$ 0.080
Requirement 5.51: (0.16 \leq 1)

The reduction factor $\chi_{-z} = 0.587$
 N_{sd} / \dots 0.023
 The reduction factor $\chi_{LT} = 1.000$
 The equiv.unif.mom.fact.(l-t.buck.) $\beta_{M,LT} = 2.423$
 Coefficient $\mu_{LT} = 0.219$
 Coefficient $k_{LT} = 0.996$

kLT * My / ...		0.058
The equiv.unif.mom.fact.flex.buck.	$\beta_z =$	2.127
Coefficient	$\mu_z =$	0.598
Coefficient	$k_z =$	0.988
$k_z * M_z / ...$		0.080

Requirement 5.52: (0.16 <= 1)

5.6 SHEAR BUCKLING RESISTANCE

For shear along z-z axis

The relevant width	d =	8.400 cm
The relevant thickness	tw =	0.800 cm
No intermediate transverse stiffeners		
Buckling factor for shear	$k_\tau =$	5.340

No check for resistance to shear buckling need be made

Requirement: d / tw <= 69 ϵ (10.50 <= 63.78)

for shear along y-y axis

The relevant width	d =	10.000 cm
The relevant thickness	tw =	0.800 cm
No intermediate transverse stiffeners		
Buckling factor for shear	$k_\tau =$	5.340

No check for resistance to shear buckling need be made

Requirement: d / tw <= 69 ϵ (12.50 <= 63.78)

5.6.7 Interaction between shear force,bend.and axial force

For shear along z-z axis

The design pl.resist.mom.(flanges)	Mf.Rd =	19.997 kNm
------------------------------------	---------	------------

Criteria 5.66a and 5.66b are satisfied

Check of the shear resistance

(load 30, at the beginning of the member)

The axial force design value	Nsd =	-9.566 kN
The shear force design value(y-y)	Vsd_y =	0.967 kN
The shear force design value(z-z)	Vsd_z =	0.769 kN
The bending mom.design value(y-y)	Msd_y =	1.200 kNm
The bending mom.design value(z-z)	Msd_z =	2.098 kNm
System length	L =	326.00 cm

5.4 RESISTANCE OF CROSS-SECTIONS

5.4.6 Shear

The design pl.shear resist.(z-z)	Vpl.Rd =	200.56 kN
----------------------------------	----------	-----------

Requirement 5.20: Vsd_z <= Vpl.Rd_z (0.77 <= 200.56)

The design pl.shear resist.(y-y)	Vpl.Rd =	200.56 kN
----------------------------------	----------	-----------

Requirement 5.20: Vsd_y <= Vpl.Rd_y (0.97 <= 200.56)

5.6 SHEAR BUCKLING RESISTANCE

For shear along z-z axis

The relevant width	d =	8.400 cm
The relevant thickness	tw =	0.800 cm
No intermediate transverse stiffeners		
Buckling factor for shear	$k_\tau =$	5.340

No check for resistance to shear buckling need be made

Requirement: d / tw <= 69 ϵ (10.50 <= 63.78)

for shear along y-y axis

The relevant width	d =	10.000 cm
The relevant thickness	tw =	0.800 cm
No intermediate transverse stiffeners		
Buckling factor for shear	$k_\tau =$	5.340

No check for resistance to shear buckling need be made

Requirement: d / tw <= 69 ϵ (12.50 <= 63.78)

BEAM 2056-4320

CROSS-SECTION: HOP [] 80x50x4 [S 275] [Set: 9]
 EUROCODE 3 (ENV)

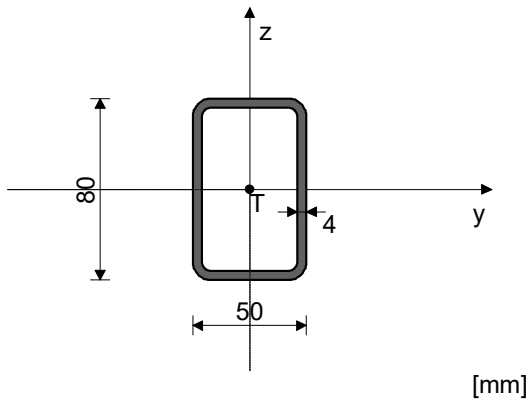
CROSS-SECTION PROPERTIES

Ax =	9.350 cm ²
Ay =	3.596 cm ²
Az =	5.754 cm ²
Ix =	82.204 cm ⁴
Iy =	72.530 cm ⁴
Iz =	34.430 cm ⁴
Wy =	18.133 cm ³
Wz =	13.772 cm ³
Wy,pl =	25.568 cm ³
Wz,pl =	18.248 cm ³
γM0 =	1.100
γM1 =	1.100
γM2 =	1.250
A _{net} /A =	0.900

[mm]

(f_y = 27.5 kN/cm², f_u = 43.0 kN/cm²)

UTILISATION FACTORS FOR ALL LOAD CASE COMBINATIONS

20. γ=0.21	10. γ=0.19	28. γ=0.19
24. γ=0.19	16. γ=0.17	12. γ=0.17
23. γ=0.17	31. γ=0.16	11. γ=0.15
18. γ=0.14	27. γ=0.14	14. γ=0.14
13. γ=0.13	22. γ=0.12	15. γ=0.12
30. γ=0.11	26. γ=0.10	17. γ=0.09
33. γ=0.08	21. γ=0.08	34. γ=0.07
19. γ=0.07	25. γ=0.06	29. γ=0.06
35. γ=0.05	32. γ=0.04	

MEMBER SUBJECT TO AXIAL COMPRESSION AND BENDING
(load 20, at the beginning of the member)

The axial force design value	Nsd =	-0.562 kN
The shear force design value(y-y)	Vsd _y =	0.547 kN
The bending mom.design value(z-z)	Msd _z =	0.517 kNm
System length	L =	819.00 cm

5.3 CLASSIFICATION OF CROSS-SECTIONS

Class 1 cross-sections

5.4 RESISTANCE OF CROSS-SECTIONS**5.4.4 Compression**

The design plastic resistance	Npl.Rd =	233.75 kN
The design compression resistance	Nc.Rd =	233.75 kN

Requirement 5.16: Nsd ≤ Nc.Rd (0.56 ≤ 233.75)**5.4.5 Bending about the z-z axis**

The design plastic resistance	Mpl.Rd =	4.562 kNm
The design local buck. resist.	Mo.Rd =	3.443 kNm
The design el.resist.moment	Mel.Rd =	3.443 kNm
The design moment resistance	Mc.Rd =	4.562 kNm

Requirement 5.17: Msd_z ≤ Mc.Rd_z (0.52 ≤ 4.56)**5.4.6 Shear**

The design pl.shear resist.(y-y)	Vpl.Rd =	51.906 kN
----------------------------------	----------	-----------

Requirement 5.20: Vsd_y ≤ Vpl.Rd_y (0.55 ≤ 51.91)**5.4.9 Bending, shear and axial force**

No reduction need be made in the resistance moment

Requirement: Vsd_y ≤ 50%Vpl.Rd_y**5.4.8 Bending and axial force**

Ratio Msd _z / Mpl.Rd _z	0.113
----------------------------------------------	-------

Requirement 5.36: (0.12 ≤ 1)**5.5. BUCKLING RESISTANCE OF MEMBERS**

5.5.1.1 Buckling resistance

Buckling length y-y	$l_{y,y} =$	819.00 cm
Radius of gyration y-y	$i_{y,y} =$	2.785 cm
Slenderness y-y	$\lambda_{y,y} =$	294.06
Relative slenderness y-y	$\lambda_{rel,y} =$	3.388
Buckling curve for axis y-y: B	$\alpha =$	0.340
The reduction factor	$\chi_{y,y} =$	0.079
The effective area factor	$\beta A =$	1.000
The design buckling resistance	$Nb.Rd_{y,y} =$	18.474 kN

Requirement 5.45: $N_{sd} \leq Nb.Rd_{y,y}$ (0.56 ≤ 18.47)

Buckling length z-z	$l_{z,z} =$	819.00 cm
Radius of gyration z-z	$i_{z,z} =$	1.919 cm
Slenderness z-z	$\lambda_{z,z} =$	426.80
Relative slenderness z-z	$\lambda_{rel,z} =$	4.917
Buckling curve for axis z-z: B	$\alpha =$	0.340
The reduction factor	$\chi_{z,z} =$	0.039
The effective area factor	$\beta A =$	1.000
The design buckling resistance	$Nb.Rd_{z,z} =$	9.045 kN

Requirement 5.45: $N_{sd} \leq Nb.Rd_{z,z}$ (0.56 ≤ 9.04)

5.5.4 Bending and axial compression

The reduction factor	$\chi_{min} =$	0.039
N_{sd} / \dots		0.062
The equiv.unif.mom.fact.flex.buck.	$\beta_z =$	1.439
Coefficient	$\mu_z =$	-5.192
Coefficient	$k_z =$	1.293
$k_z * M_z / \dots$		0.146

Requirement 5.51: (0.21 ≤ 1)

5.6 SHEAR BUCKLING RESISTANCE

for shear along y-y axis

The relevant width	$d =$	5.000 cm
The relevant thickness	$t_w =$	0.400 cm
No intermediate transverse stiffeners		
Buckling factor for shear	$k_{\tau} =$	5.340

No check for resistance to shear buckling need be made

Requirement: $d / t_w \leq 69 \epsilon$ (12.50 ≤ 63.78)

Check of the shear resistance

(load 20, at 326.0 cm from the start of the member)

The axial force design value	$N_{sd} =$	-0.225 kN
The shear force design value(y-y)	$V_{sd,y} =$	0.704 kN
The bending mom.design value(z-z)	$M_{sd,z} =$	0.607 kNm
System length	$L =$	819.00 cm

5.4 RESISTANCE OF CROSS-SECTIONS

5.4.6 Shear

The design pl.shear resist.(y-y)	$V_{pl.Rd} =$	51.906 kN
----------------------------------	---------------	-----------

Requirement 5.20: $V_{sd,y} \leq V_{pl.Rd,y}$ (0.70 ≤ 51.91)

5.6 SHEAR BUCKLING RESISTANCE

for shear along y-y axis

The relevant width	$d =$	5.000 cm
The relevant thickness	$t_w =$	0.400 cm
No intermediate transverse stiffeners		
Buckling factor for shear	$k_{\tau} =$	5.340

No check for resistance to shear buckling need be made

Requirement: $d / t_w \leq 69 \epsilon$ (12.50 ≤ 63.78)