

**TITULLI I PROJEKTIT**

“REHABILITIMI I INFRASTRUKTURËS RRUGORE  
NË NJËSINË ADMINISTRATIVE  
VAQARR - PEZË - NDROQ”

FAZA

PROJEKT ZBATIM

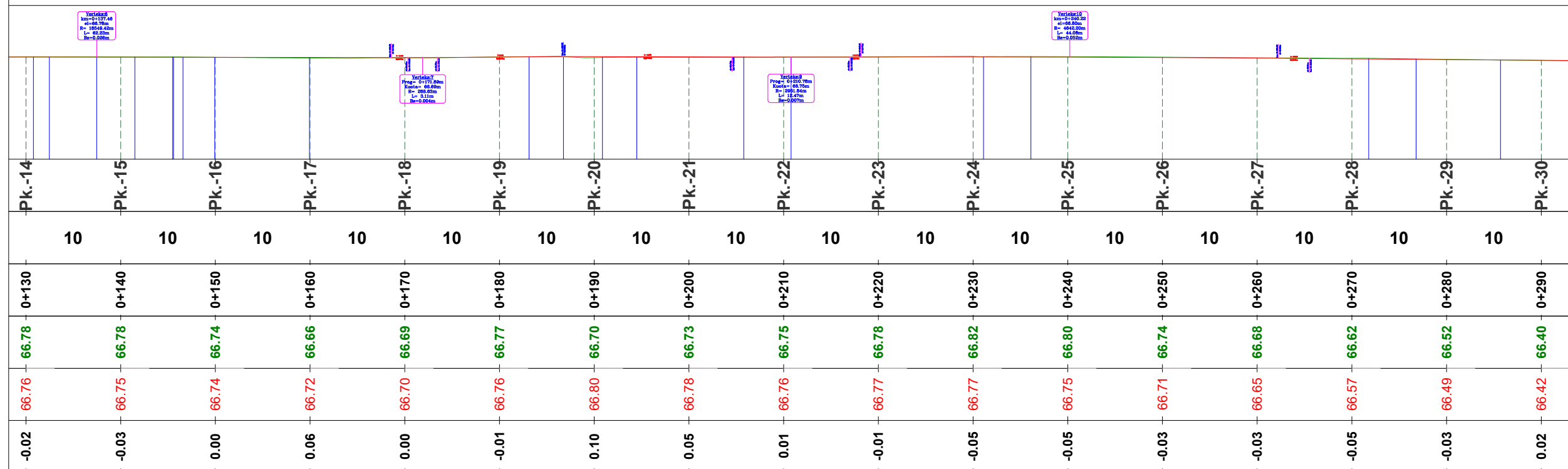

**RRUGA "BREGU I ERZENIT"**

EMËRTIMI I FLETËS: PROFILI GJATESOR

SHKALLA **1:500**

NUMRI I FLETËS **T-190**

2024

AUTORITETI KONTRAKTOR:  
BASHKIA TIRANË



PROJEKTUESI: "NET-GROUP" SH.P.K



**TITULLI I PROJEKTIT**

“REHABILITIMI I INFRASTRUKTURËS RRUGORE  
NË NJËSINË ADMINISTRATIVE  
VAQARR - PEZË - NDROQ”

FAZA

PROJEKT ZBATIM

**Profili Gjat**

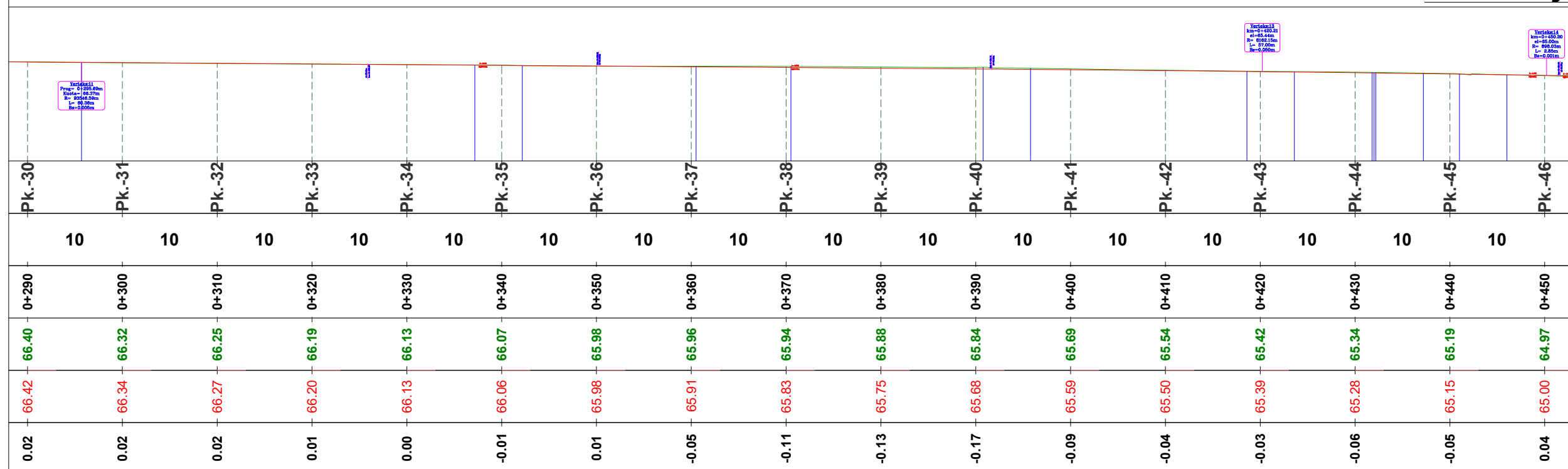

**RRUGA "BREGU I ERZENIT"**

EMËRTIMI I FLETËS: PROFILI GJATESOR

SHKALLA **1:500**

NUMRI I FLETËS **T-191**

2024

AUTORITETI KONTRAKTOR:  
BASHKIA TIRANË



PROJEKTUESI: "NET-GROUP" SH.P.K



**TITULLI I PROJEKTIT**

“REHABILITIMI I INFRASTRUKTURËS RRUGORE  
NË NJËSINË ADMINISTRATIVE  
VAQARR - PEZË - NDRIQ”

FAZA

PROJEKT ZBATIM

**i Gjatesor**

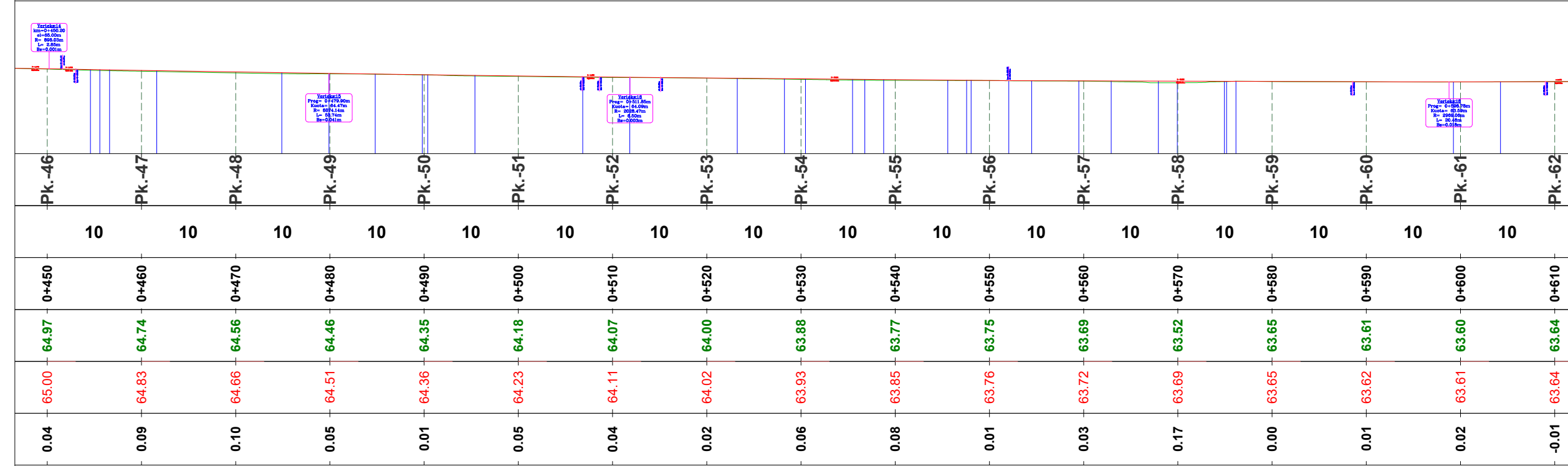

**RRUGA "BREGU I ERZENIT"**

EMËRTIMI I FLETËS: PROFILI GJATESOR

SHKALLA **1:500**

NUMRI I FLETËS **T-192**

2024

AUTORITETI KONTRAKTOR:  
BASHKIA TIRANË



PROJEKTUESI: "NET-GROUP" SH.P.K



**TITULLI I PROJEKTIT**

“REHABILITIMI I INFRASTRUKTURËS RRUGORE  
NË NJËSINË ADMINISTRATIVE  
VAQARR - PEZË - NDROQ”

FAZA

PROJEKT ZBATIM

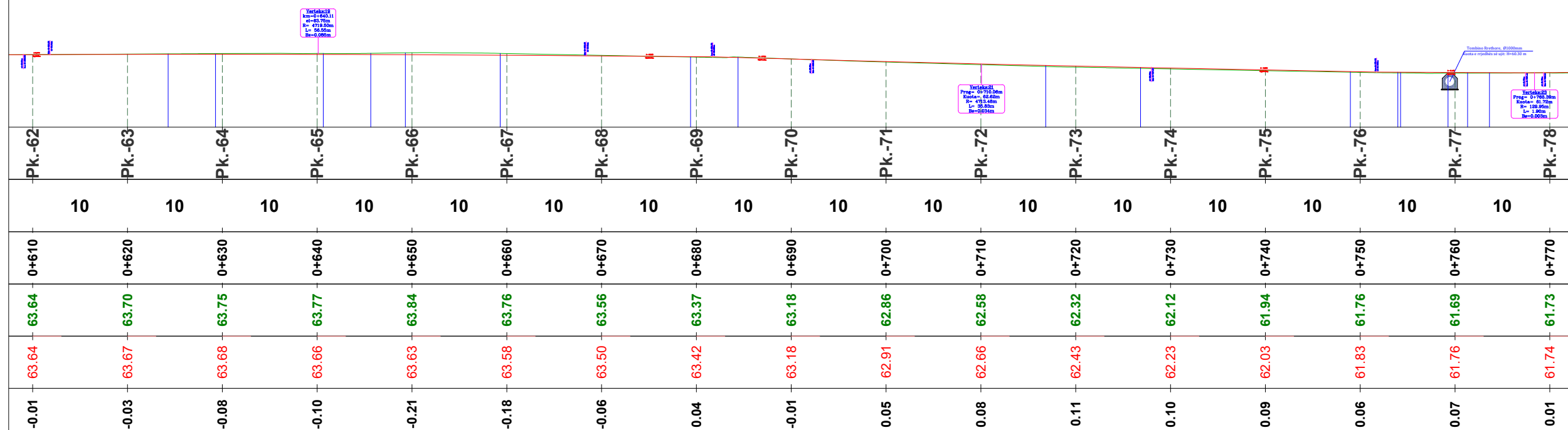

**RRUGA "BREGU I ERZENIT"**

EMËRTIMI I FLETËS: PROFILI GJATESOR

SHKALLA **1:500**

NUMRI I FLETËS **T-193**

2024

AUTORITETI KONTRAKTOR:  
BASHKIA TIRANË



PROJEKTUESI: "NET-GROUP" SH.P.K



**TITULLI I PROJEKTIT**

“REHABILITIMI I INFRASTRUKTURËS RRUGORE  
NË NJËSINË ADMINISTRATIVE  
VAQARR - PEZË - NDROQ”

FAZA

PROJEKT ZBATIM

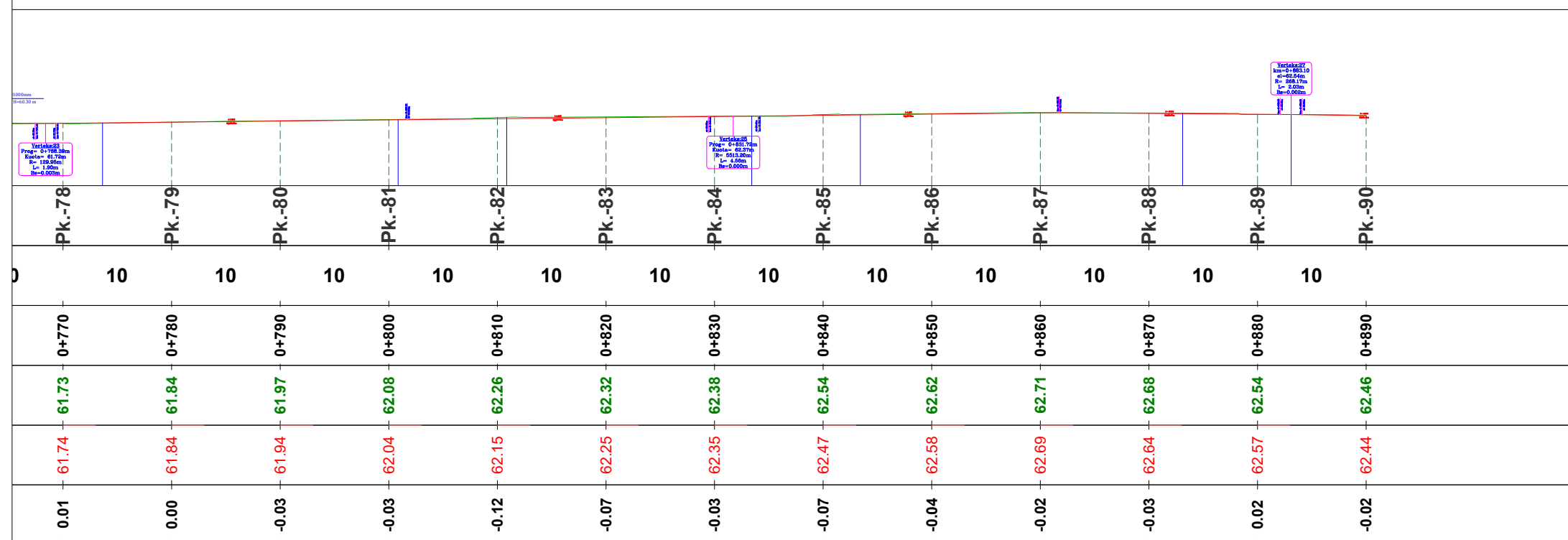

**RRUGA "BREGU I ERZENIT"**

EMËRTIMI I FLETËS: PROFILI GJATESOR

SHKALLA **1:500**

NUMRI I FLETËS **T-194**

2024

AUTORITETI KONTRAKTOR:  
BASHKIA TIRANË



PROJEKTUESI: "NET-GROUP" SH.P.K



TITULLI I PROJEKTIT

“REHABILITIMI I INFRASTRUKTURËS RRUGORE  
NË NJËSINË ADMINISTRATIVE  
VAQARR - PEZË - NDRIQ”

FAZA

PROJEKT ZBATIM

RRUGA "BREGU I ERZENIT"

EMËRTIMI I FLETËS: SEKSIONET TERTHORE

SHKALLA **1:250**

NUMRI I FLETËS **T-195**

2024

AUTORITETI KONTRAKTOR:  
BASHKIA TIRANË



PROJEKTUESI: "NET-GROUP" SH.P.K

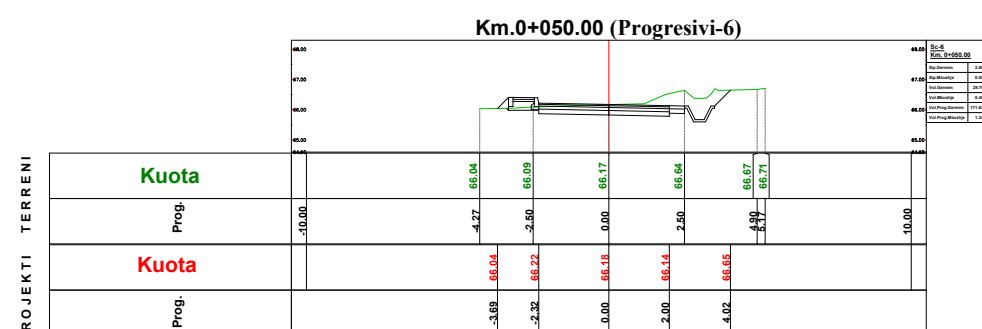
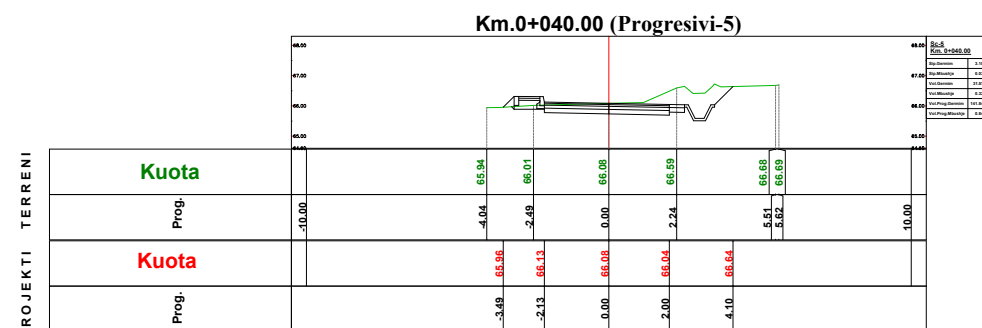
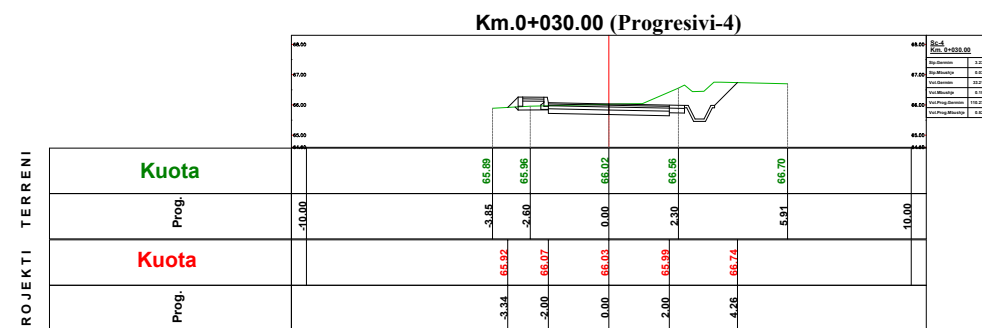
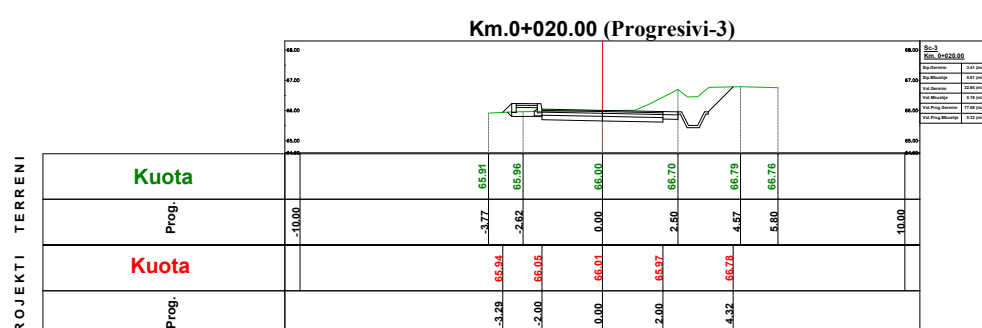
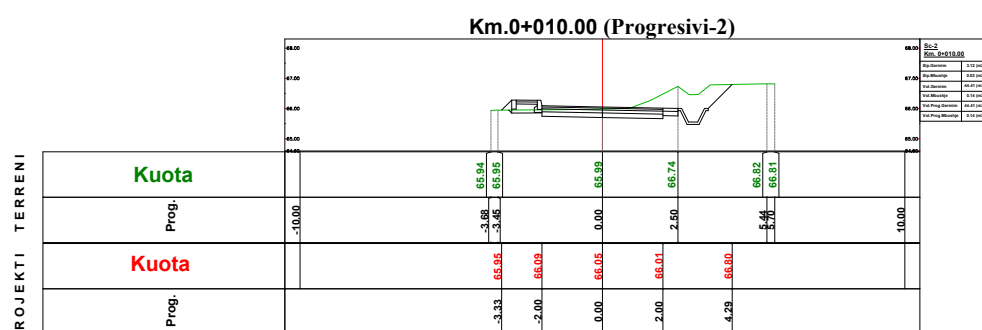
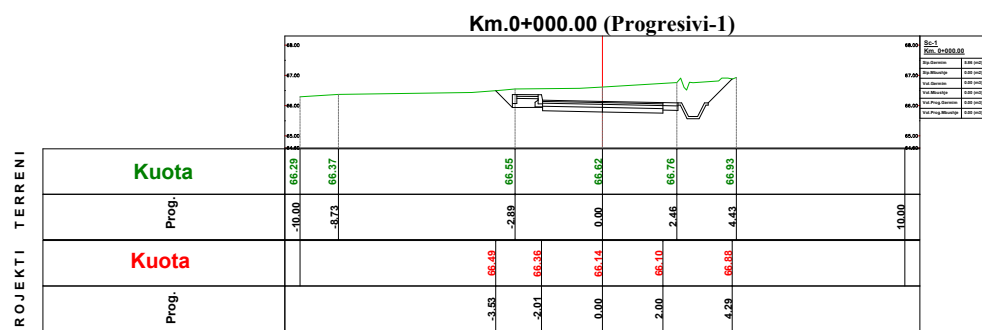

TITULLI I PROJEKTIT

“REHABILITIMI I INFRASTRUKTURËS RRUGORE  
NË NJËSINË ADMINISTRATIVE  
VAQARR - PEZË - NDRROQ”

FAZA

PROJEKT ZBATIM

RRUGA "BREGU I ERZENIT"

EMËRTIMI I FLETËS: SEKSIONET TERTHORE

SHKALLA 1:250

NUMRI I FLETËS T-196

2024

AUTORITETI KONTRAKTOR:  
BASHKIA TIRANË



PROJEKTUESI: "NET-GROUP" SH.P.K

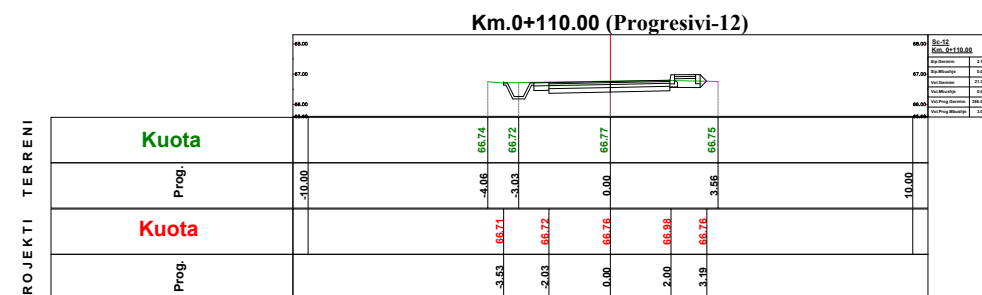
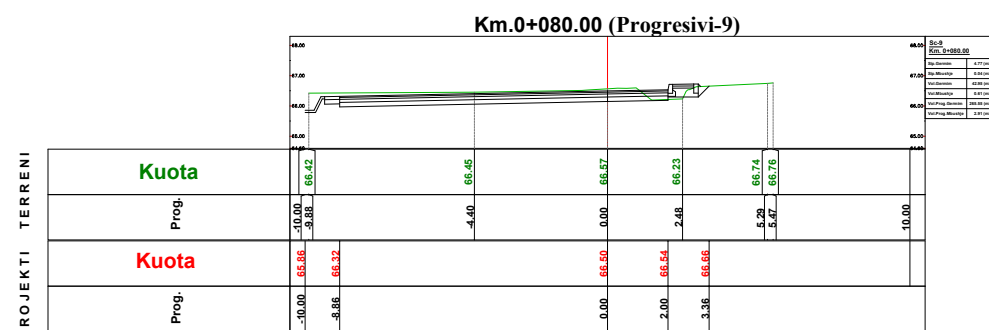
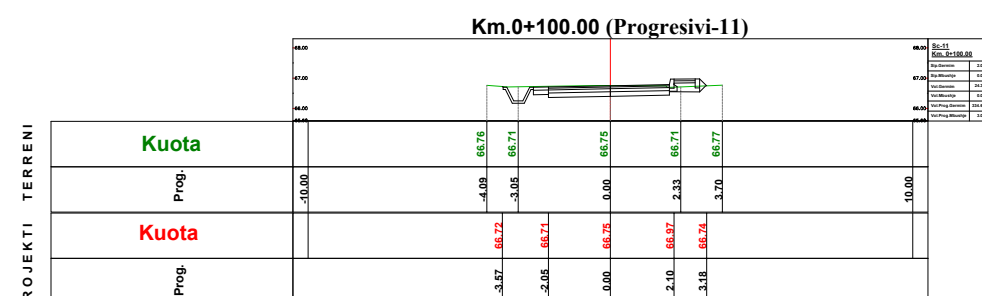
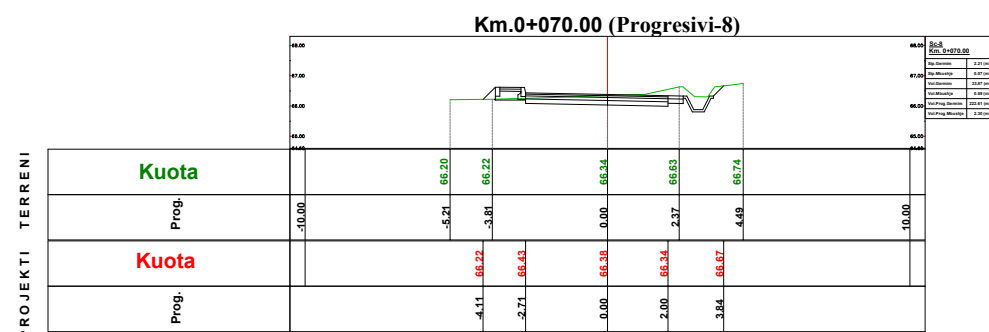
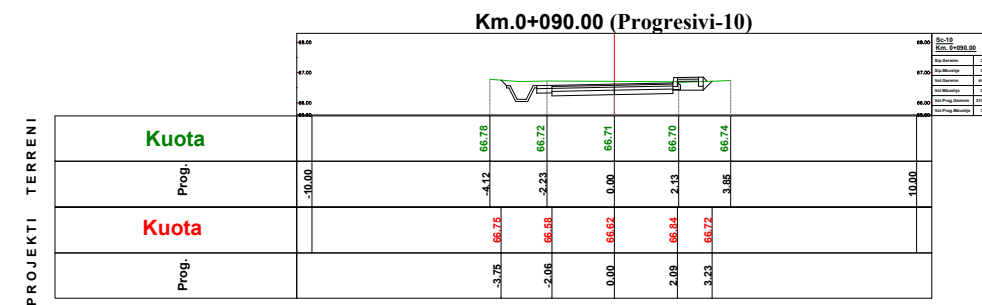
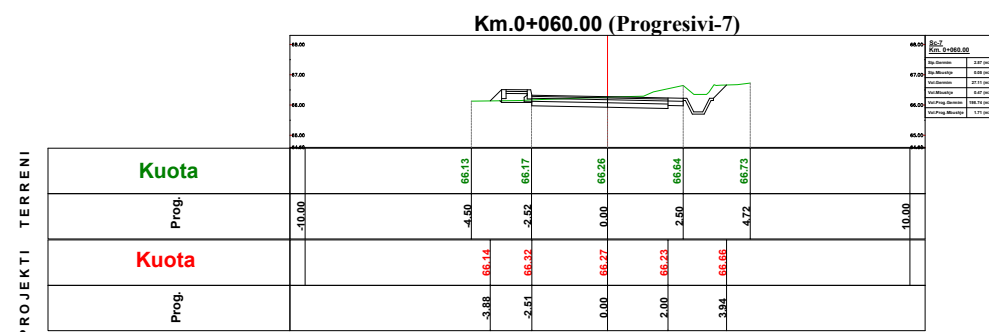

**TITULLI I PROJEKTIT**

“REHABILITIMI I INFRASTRUKTURËS RRUGORE  
NË NJËSINË ADMINISTRATIVE  
VAQARR - PEZË - NDRIQ”

FAZA

PROJEKT ZBATIM

RRUGA "BREGU I ERZENIT"

EMËRTIMI I FLETËS: SEKSIONET TERTHORE

SHKALLA **1:250**

NUMRI I FLETËS **T-197**

2024

AUTORITETI KONTRAKTOR:  
BASHKIA TIRANË



PROJEKTUESI: "NET-GROUP" SH.P.K



**Km.0+120.00 (Progresivi-13)**

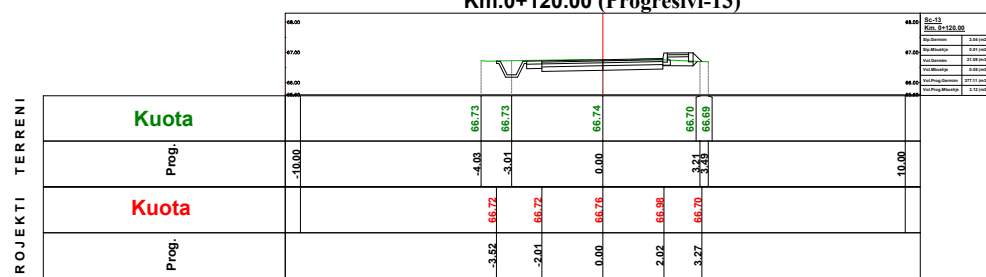

**Km.0+130.00 (Progresivi-14)**

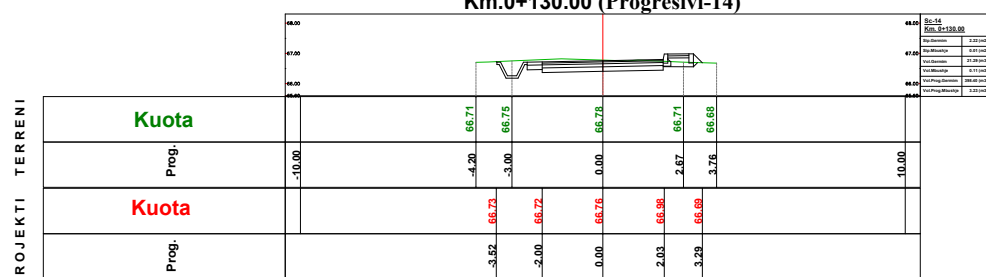

**Km.0+140.00 (Progresivi-15)**

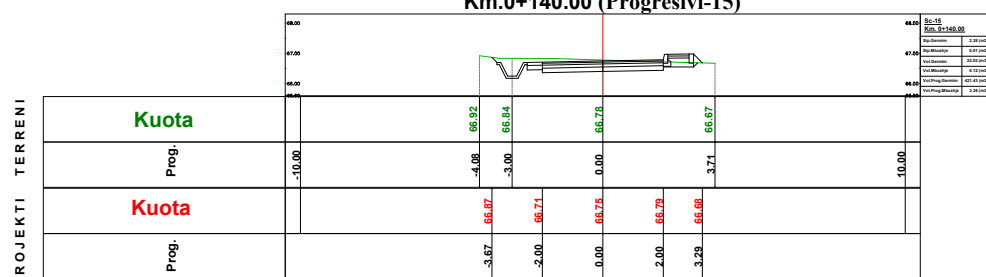

**Km.0+150.00 (Progresivi-16)**

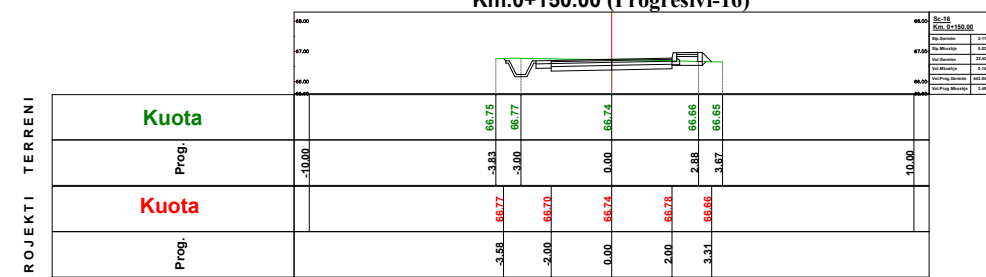

**Km.0+160.00 (Progresivi-17)**

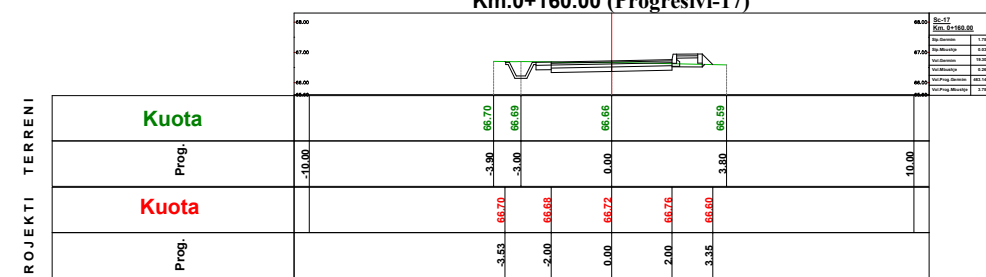

**Km.0+170.00 (Progresivi-18)**

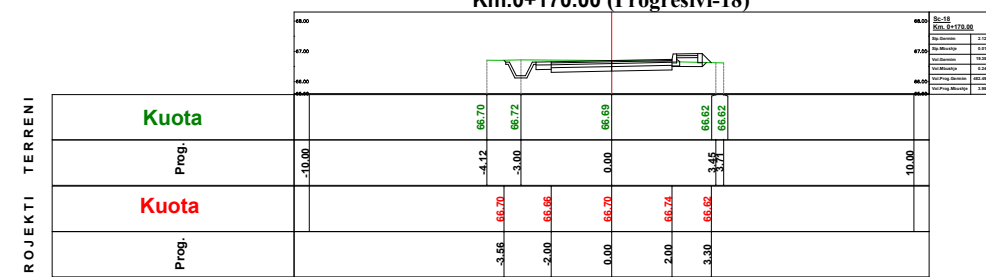



TITULLI I PROJEKTIT

“REHABILITIMI I INFRASTRUKTURËS RRUGORE  
NË NJËSINË ADMINISTRATIVE  
VAQARR - PEZË - NDRROQ”

FAZA

PROJEKT ZBATIM

RRUGA "BREGU I ERZENIT"

EMËRTIMI I FLETËS: SEKSIONET TERTHORE

SHKALLA 1:250

NUMRI I FLETËS T-198

2024

AUTORITETI KONTRAKTOR:  
BASHKIA TIRANË



PROJKTUESI: "NET-GROUP" SH.P.K

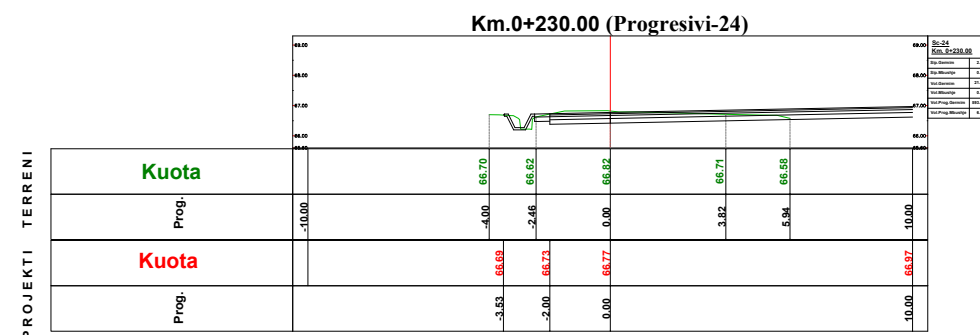
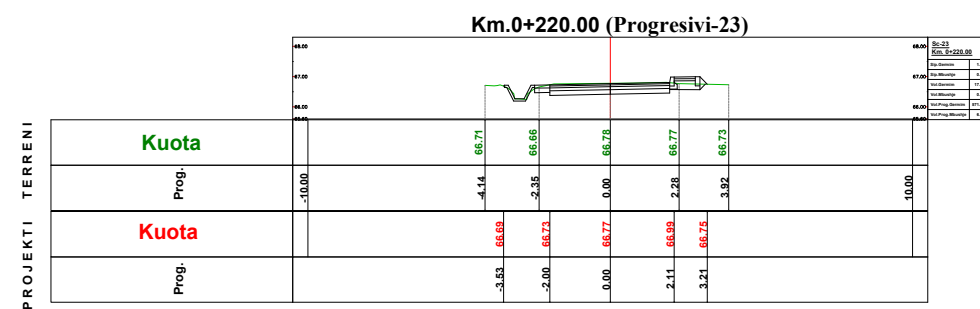
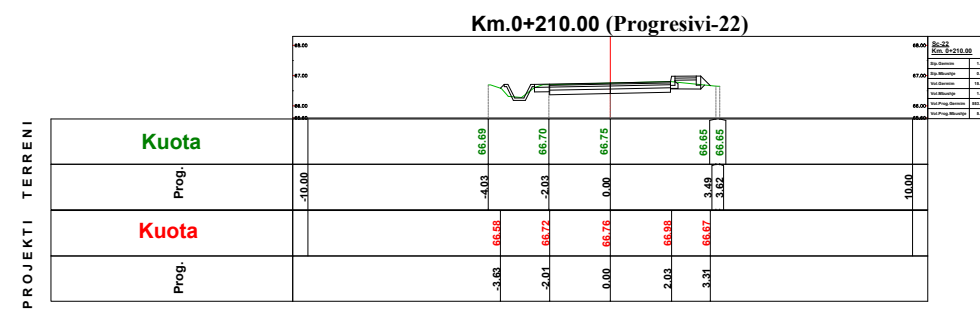
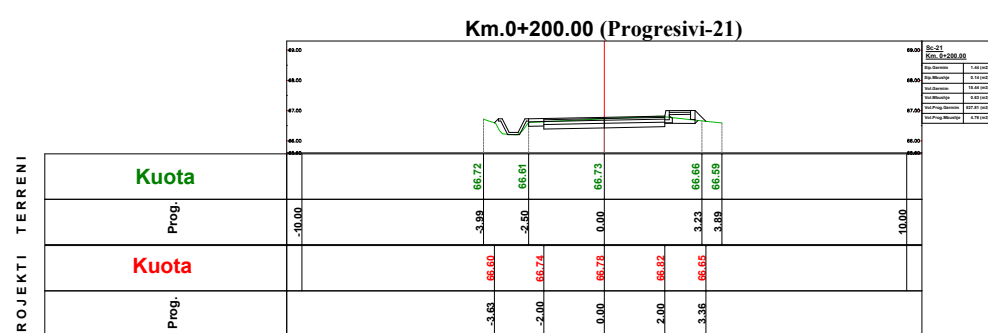
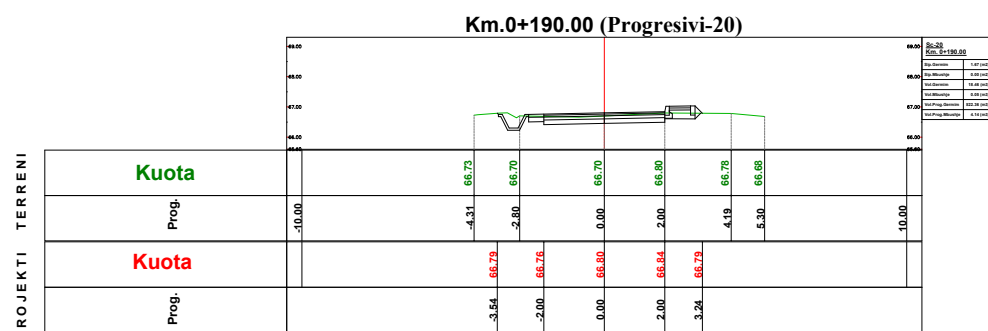
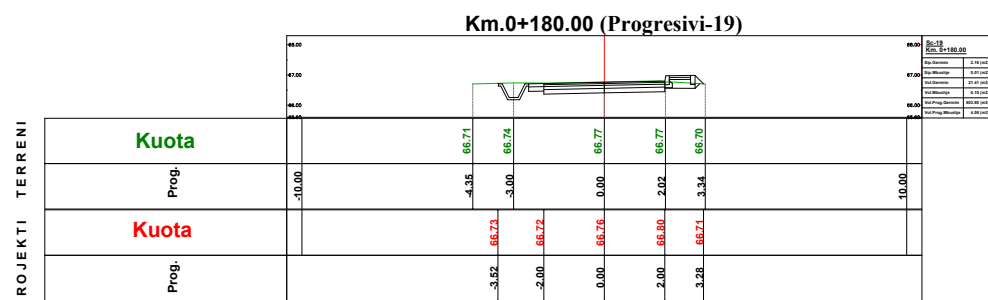

TITULLI I PROJEKTIT

“REHABILITIMI I INFRASTRUKTURËS RRUGORE  
NË NJËSINË ADMINISTRATIVE  
VAQARR - PEZË - NDRQO”

FAZA

PROJEKT ZBATIM

RRUGA "BREGU I ERZENIT"

EMËRTIMI I FLETËS: SEKSIONET TERTHORE

SHKALLA **1:250**

NUMRI I FLETËS **T-199**

2024

AUTORITETI KONTRAKTOR:  
BASHKIA TIRANË



PROJEKTUESI: "NET-GROUP" SH.P.K

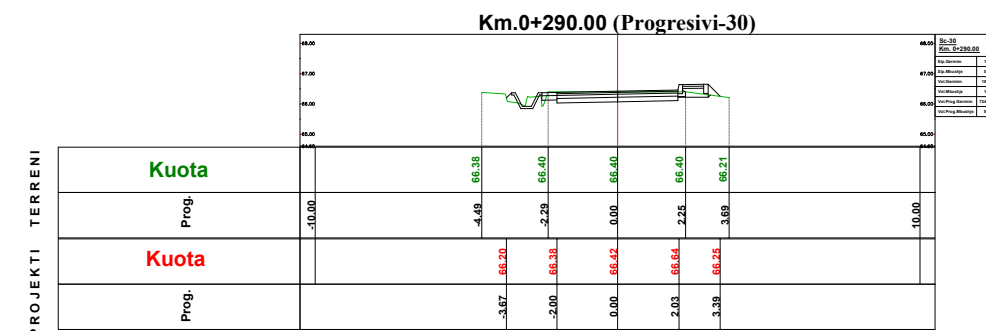
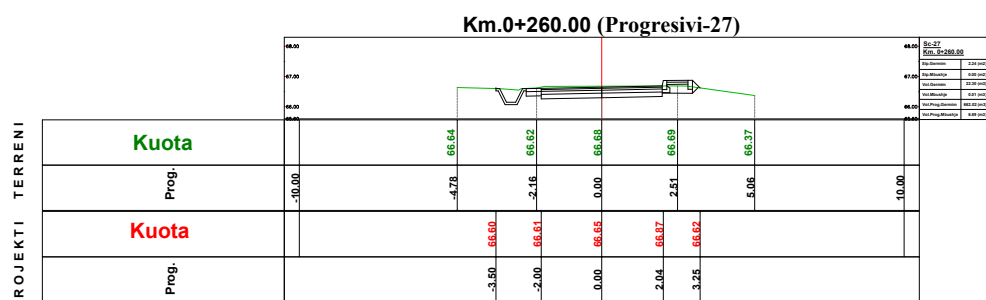
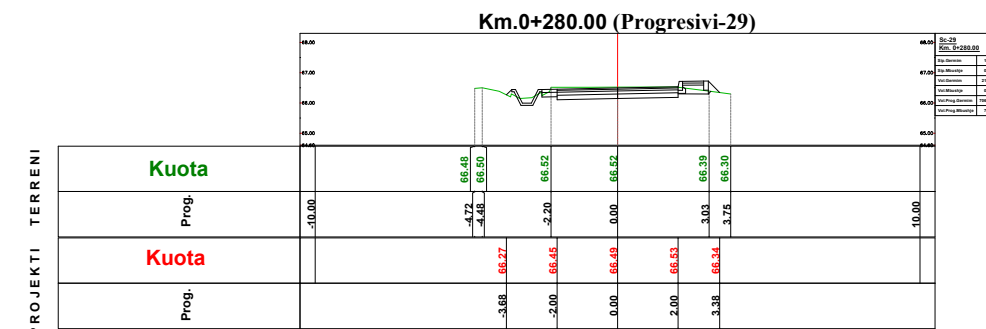
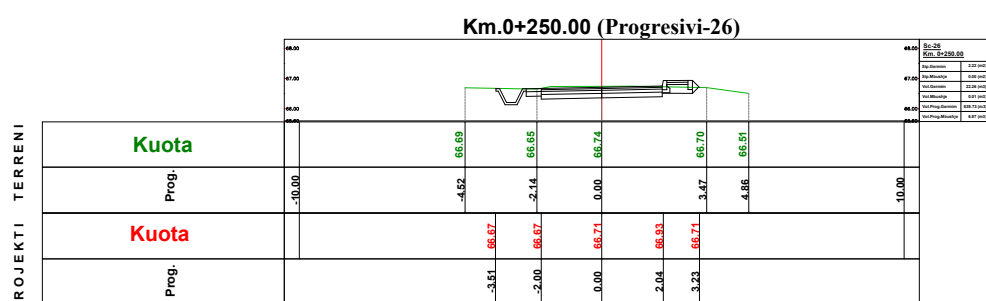
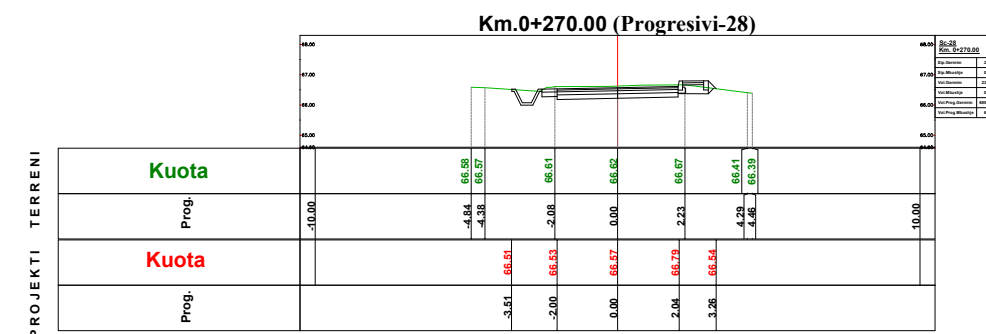
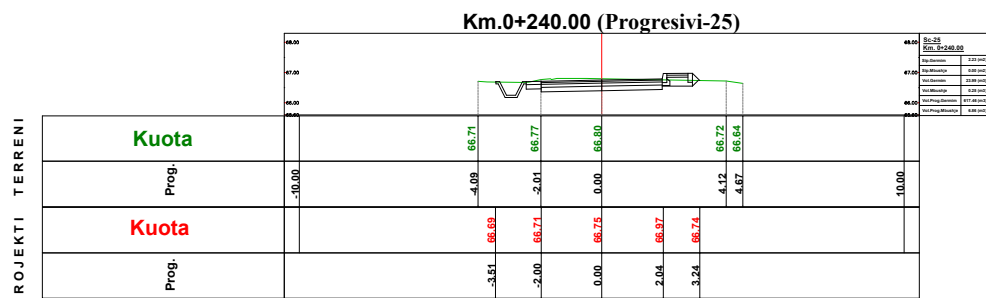

TITULLI I PROJEKTIT

“REHABILITIMI I INFRASTRUKTURËS RRUGORE  
NË NJËSINË ADMINISTRATIVE  
VAQARR - PEZË - NDRROQ”

FAZA

PROJEKT ZBATIM

RRUGA "BREGU I ERZENIT"

EMËRTIMI I FLETËS: SEKSIONET TERTHORE

SHKALLA **1:250**

NUMRI I FLETËS **T-200**

2024

AUTORITETI KONTRAKTOR:  
BASHKIA TIRANË



PROJEKTUESI: "NET-GROUP" SH.P.K



Km.0+300.00 (Progresivi-31)

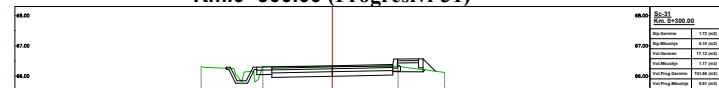

PROJEKTI TERRENI	Kuota								
	Prog.		66.30	66.32	66.32	66.32	66.32	66.32	66.12
PROJEKTI TERRENI	Kuota								
	Prog.	-10.00	-4.34	-2.30	0.00	2.00	3.41		

Km.0+330.00 (Progresivi-34)

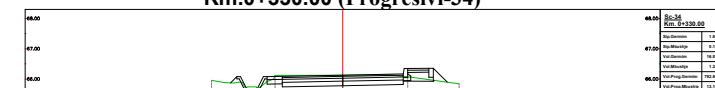

PROJEKTI TERRENI	Kuota								
	Prog.		65.99	66.12	66.13	66.07	65.84		
PROJEKTI TERRENI	Kuota								
	Prog.	-10.00	-4.34	-2.24	0.00	2.00	3.46		

Km.0+310.00 (Progresivi-32)



PROJEKTI TERRENI	Kuota								
	Prog.		66.16	66.26	66.26	66.23	66.03		
PROJEKTI TERRENI	Kuota								
	Prog.	-10.00	-4.47	-2.28	0.00	2.00	3.42		

Km.0+340.00 (Progresivi-35)

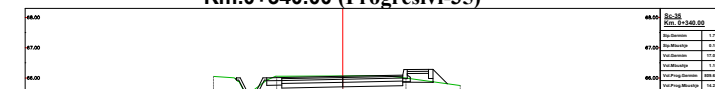

PROJEKTI TERRENI	Kuota								
	Prog.		66.05	66.05	66.07	66.00	65.75		
PROJEKTI TERRENI	Kuota								
	Prog.	-10.00	-4.47	-2.01	0.00	2.02	3.46		

Km.0+320.00 (Progresivi-33)

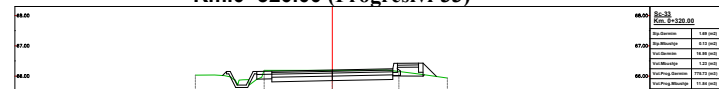

PROJEKTI TERRENI	Kuota								
	Prog.		66.03	66.19	66.19	66.15	65.93		
PROJEKTI TERRENI	Kuota								
	Prog.	-10.00	-4.53	-2.26	0.00	2.00	3.44		

Km.0+350.00 (Progresivi-36)

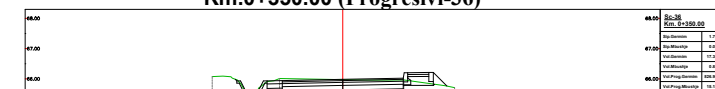

PROJEKTI TERRENI	Kuota								
	Prog.		66.07	66.01	65.98	65.97	65.71		
PROJEKTI TERRENI	Kuota								
	Prog.	-10.00	-4.31	-2.08	0.00	2.00	3.45		

TITULLI I PROJEKTIT

“REHABILITIMI I INFRASTRUKTURËS RRUGORE  
NË NJËSINË ADMINISTRATIVE  
VAQARR - PEZË - NDRROQ”

FAZA

PROJEKT ZBATIM

RRUGA "BREGU I ERZENIT"

EMËRTIMI I FLETËS: SEKSIONET TERTHORE

SHKALLA **1:250**

NUMRI I FLETËS **T-201**

2024

AUTORITETI KONTRAKTOR:  
BASHKIA TIRANË



PROJEKTUESI: "NET-GROUP" SH.P.K

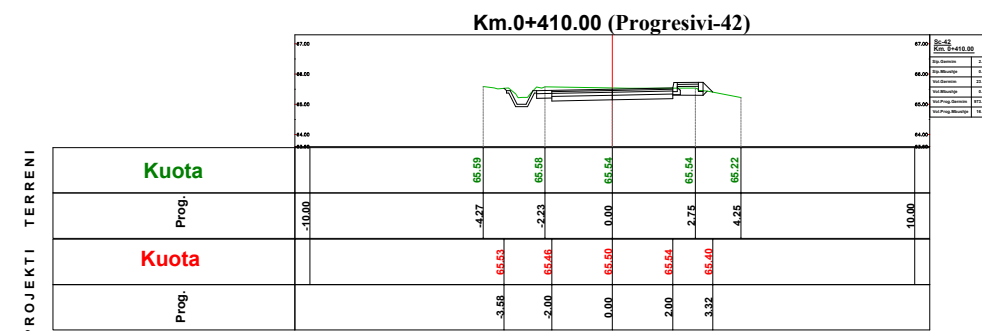
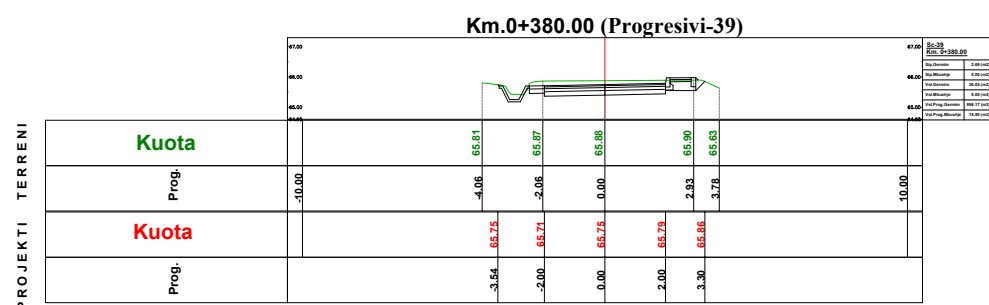
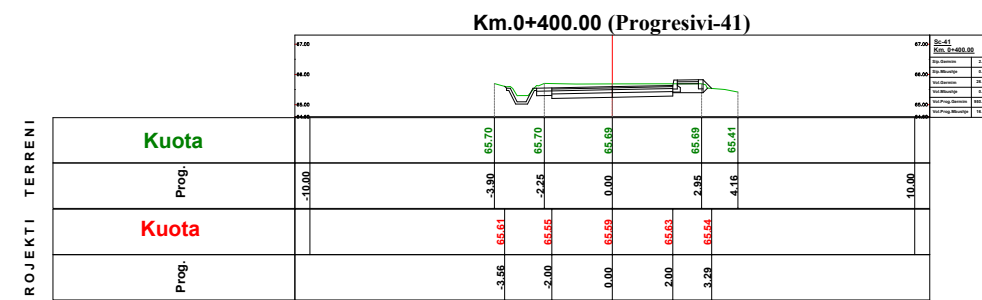
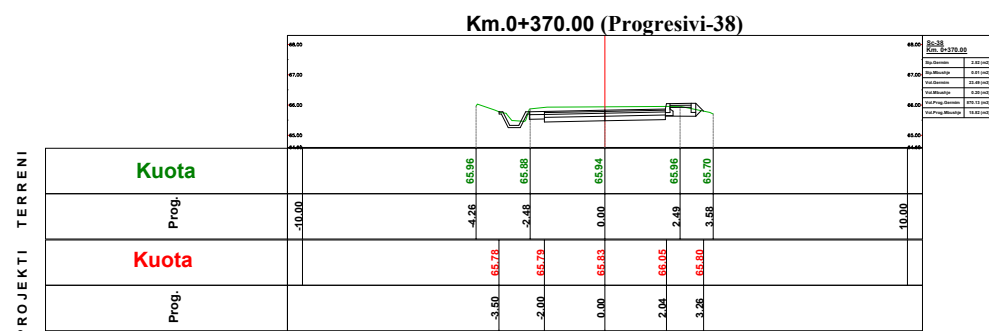
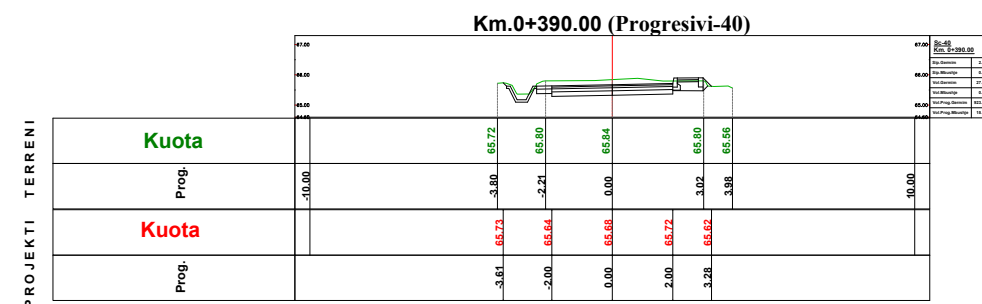
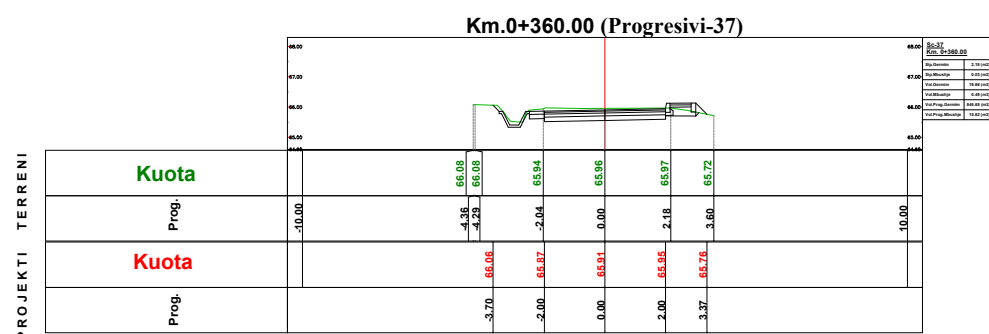

TITULLI I PROJEKTIT

“REHABILITIMI I INFRASTRUKTURËS RRUGORE  
NË NJËSINË ADMINISTRATIVE  
VAQARR - PEZË - NDRUQ”

FAZA

PROJEKT ZBATIM

RRUGA "BREGU I ERZENIT"

EMËRTIMI I FLETËS: SEKSIONET TERTHORE

SHKALLA 1:250

NUMRI I FLETËS T-202

2024

AUTORITETI KONTRAKTOR:  
BASHKIA TIRANË



PROJEKTUESI: "NET-GROUP" SH.P.K

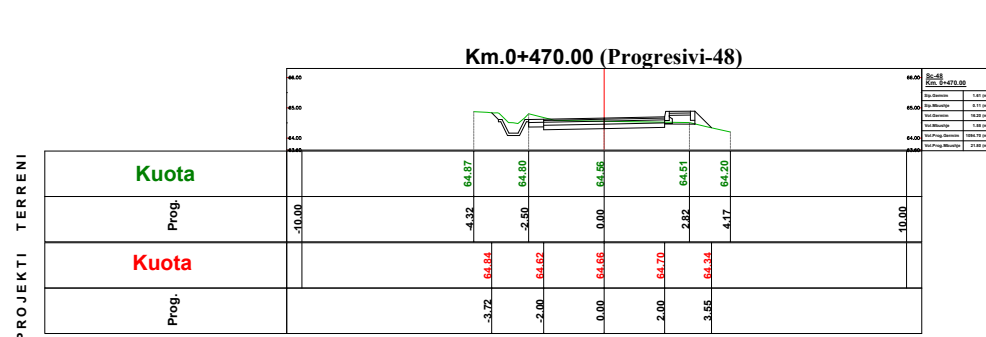
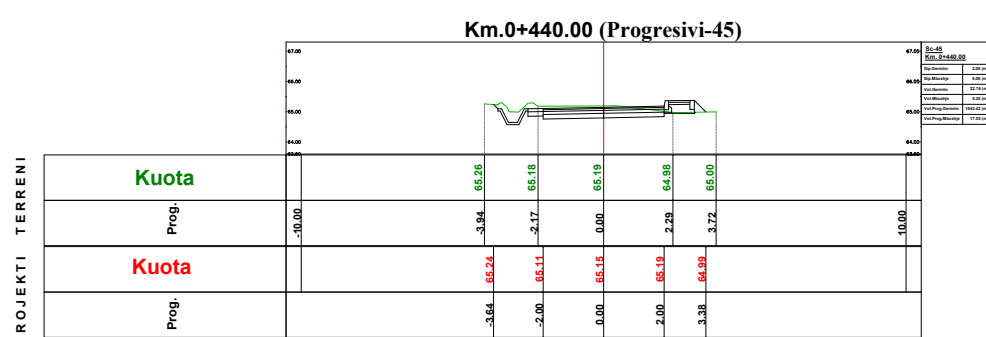
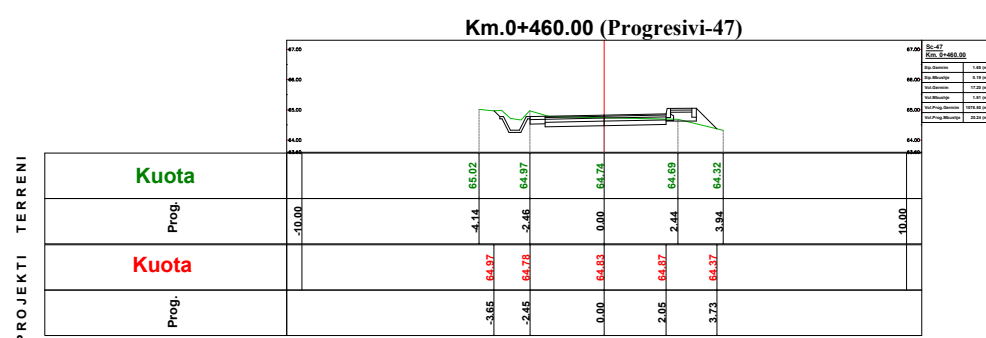
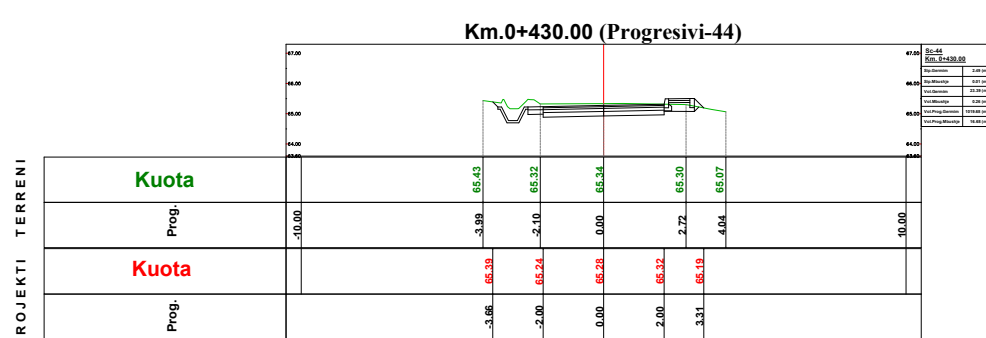
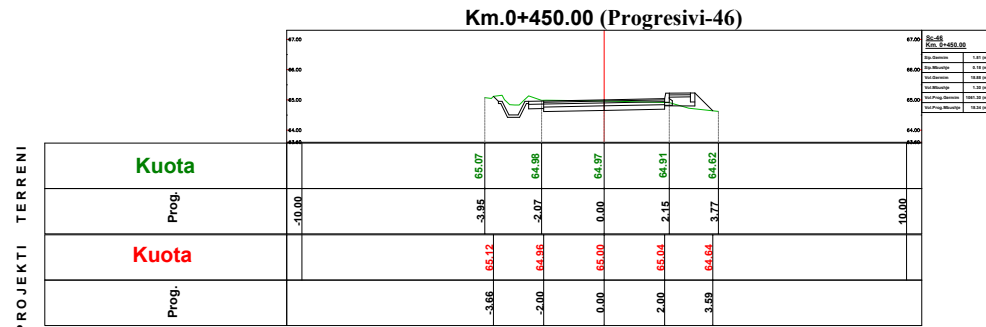
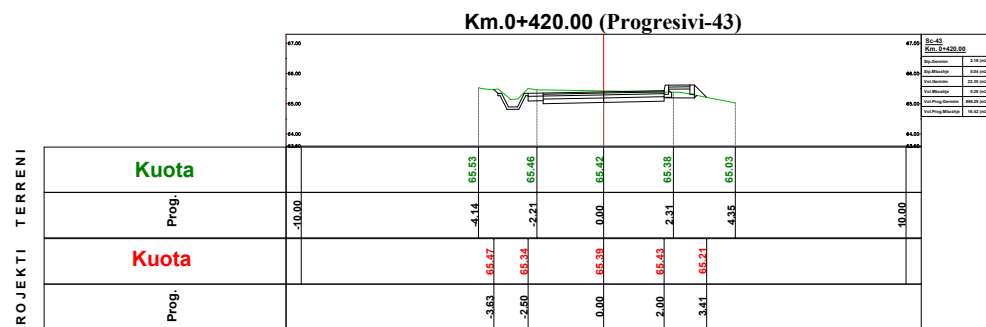

TITULLI I PROJEKTIT

“REHABILITIMI I INFRASTRUKTURËS RRUGORE  
NË NJËSINË ADMINISTRATIVE  
VAQARR - PEZË - NDRQ”

FAZA

PROJEKT ZBATIM

RRUGA "BREGU I ERZENIT"

EMËRTIMI I FLETËS: SEKSIONET TERTHORE

SHKALLA 1:250

NUMRI I FLETËS T-203

2024

AUTORITETI KONTRAKTOR:  
BASHKIA TIRANË



PROJEKTUESI: "NET-GROUP" SH.P.K

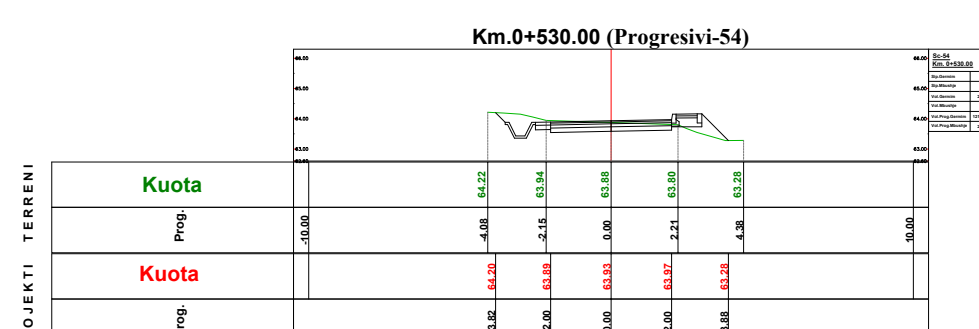
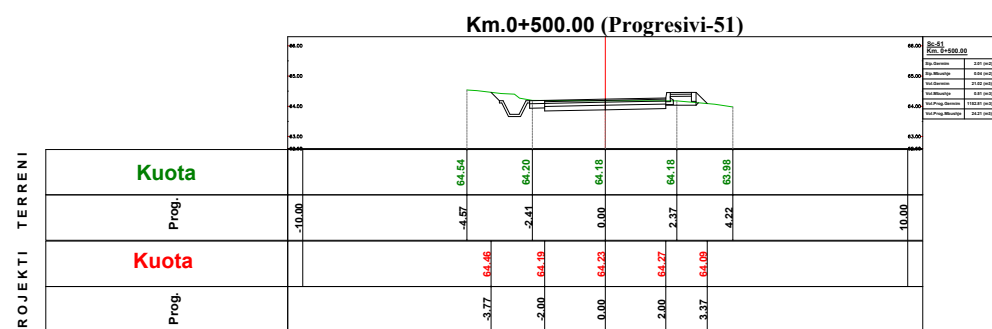
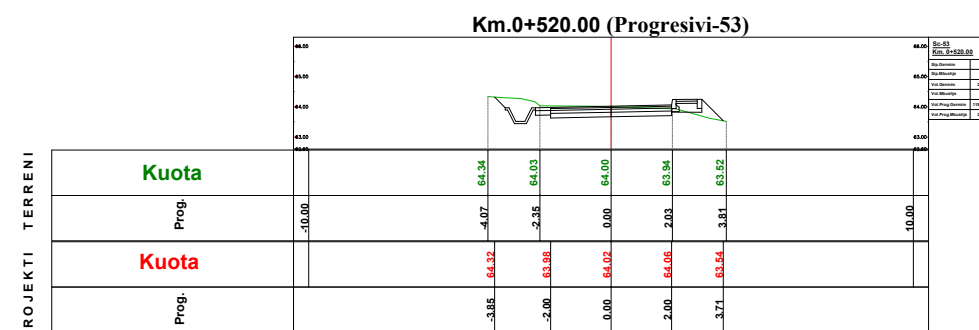
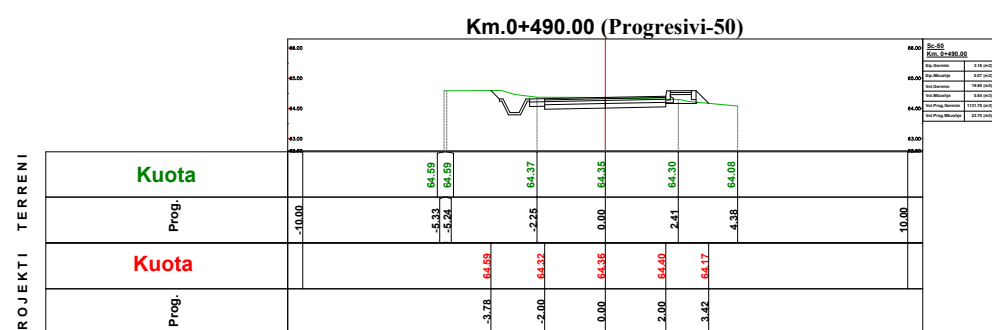
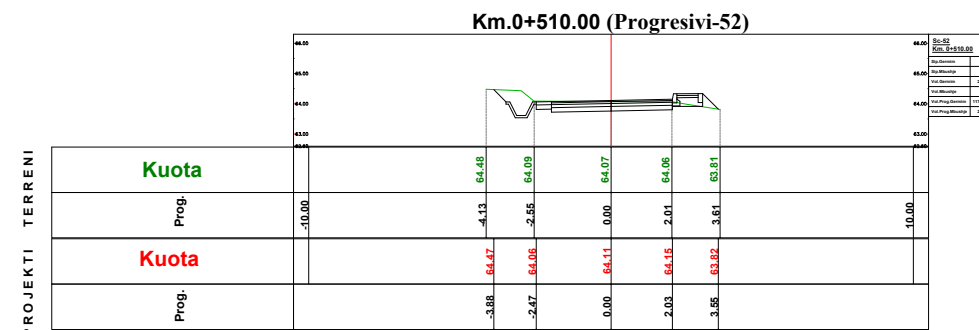
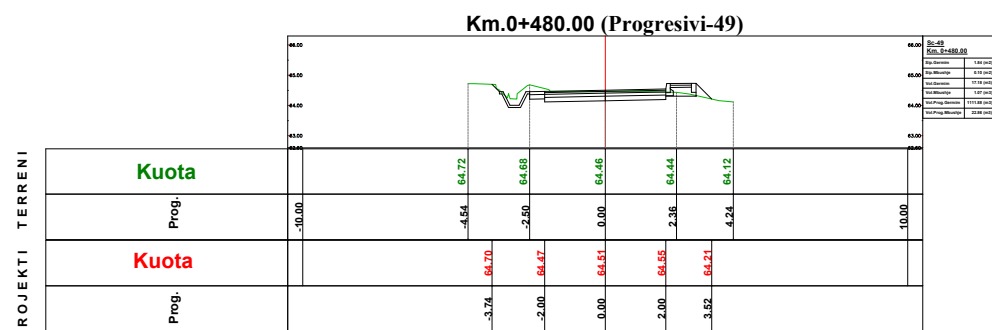

TITULLI I PROJEKTIT

“REHABILITIMI I INFRASTRUKTURËS RRUGORE  
NË NJËSINË ADMINISTRATIVE  
VAQARR - PEZË - NDRUQ”

FAZA

PROJEKT ZBATIM

RRUGA "BREGU I ERZENIT"

EMËRTIMI I FLETËS: SEKSIONET TERTHORE

SHKALLA 1:250

NUMRI I FLETËS T-204

2024

AUTORITETI KONTRAKTOR:  
BASHKIA TIRANË



PROJEKTUESI: "NET-GROUP" SH.P.K

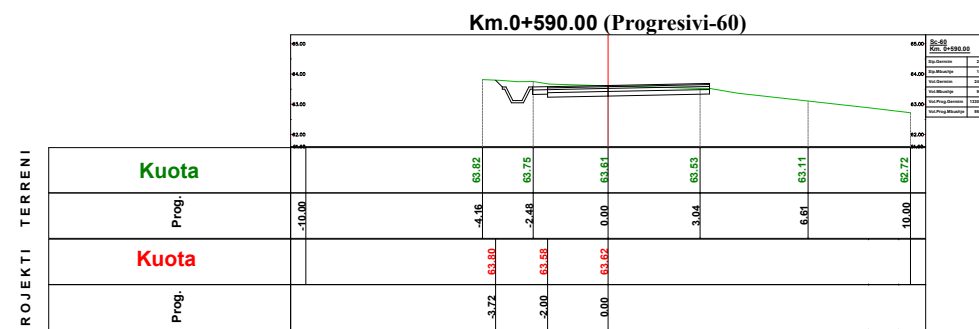
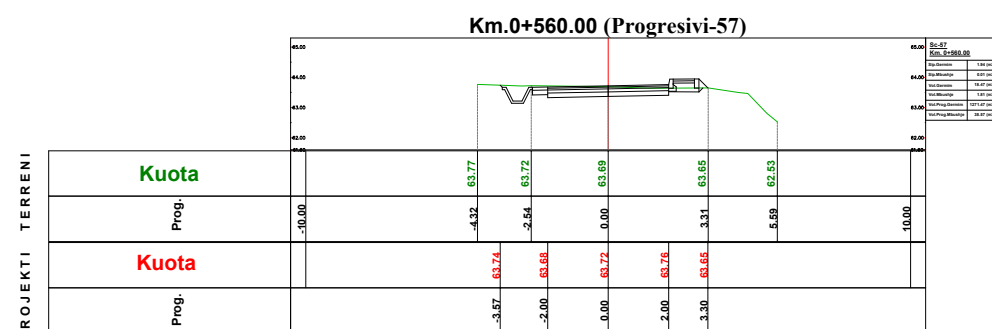
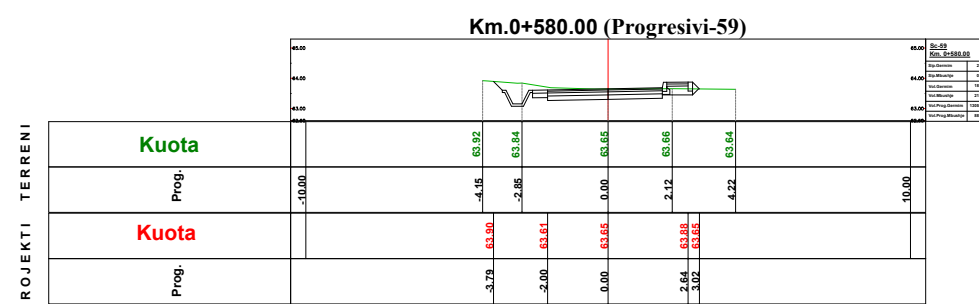
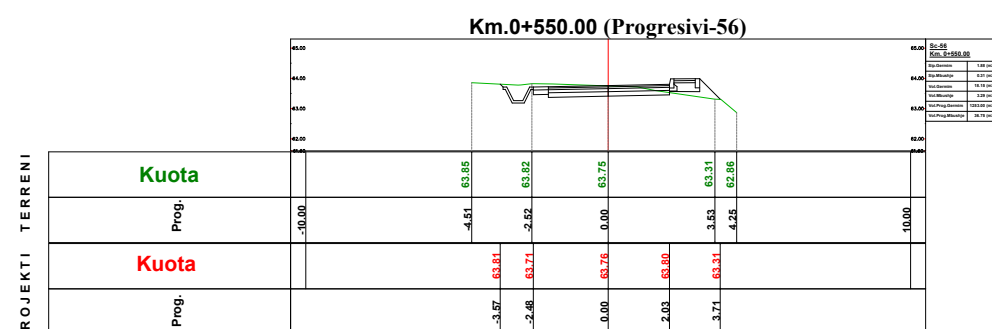
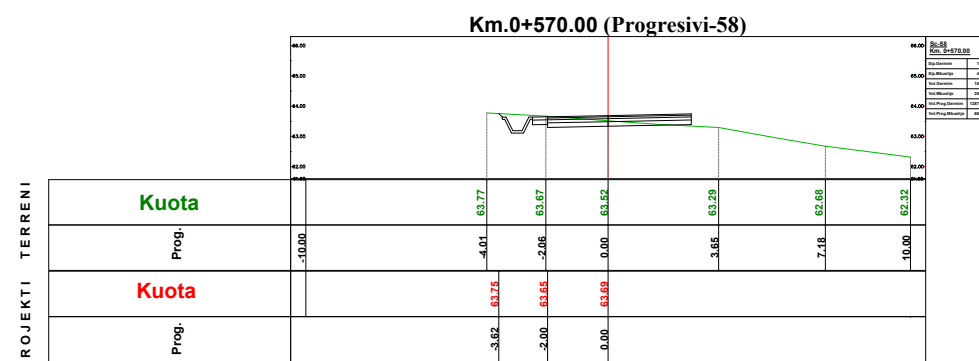
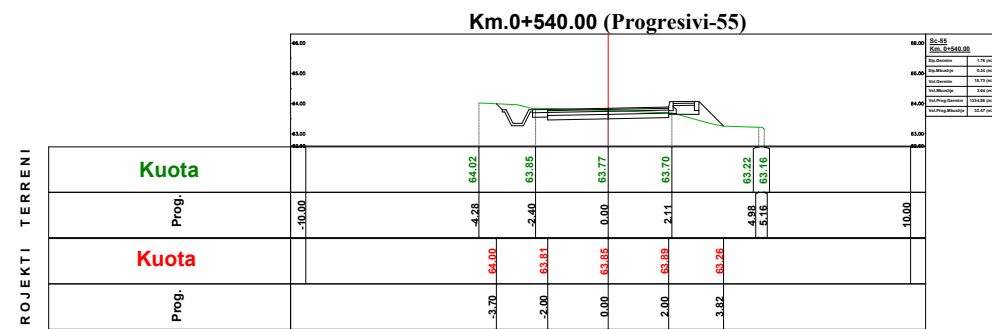

TITULLI I PROJEKTIT

“REHABILITIMI I INFRASTRUKTURËS RRUGORE  
NË NJËSINË ADMINISTRATIVE  
VAQARR - PEZË - NDRQO”

FAZA

PROJEKT ZBATIM

RRUGA "BREGU I ERZENIT"

EMËRTIMI I FLETËS: SEKSIONET TERTHORE

SHKALLA 1:250

NUMRI I FLETËS T-205

2024

AUTORITETI KONTRAKTOR:  
BASHKIA TIRANË



PROJEKTUESI: "NET-GROUP" SH.P.K

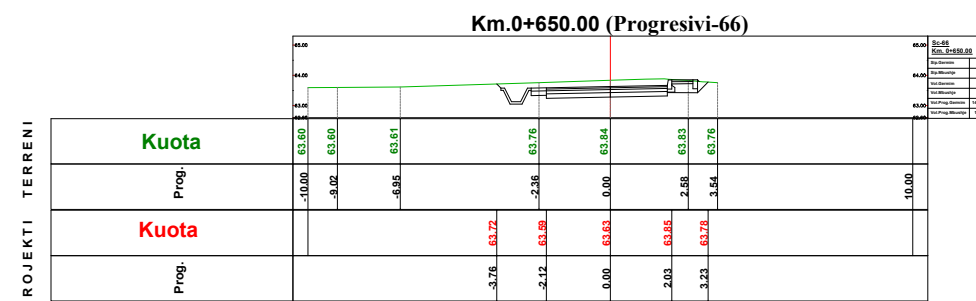
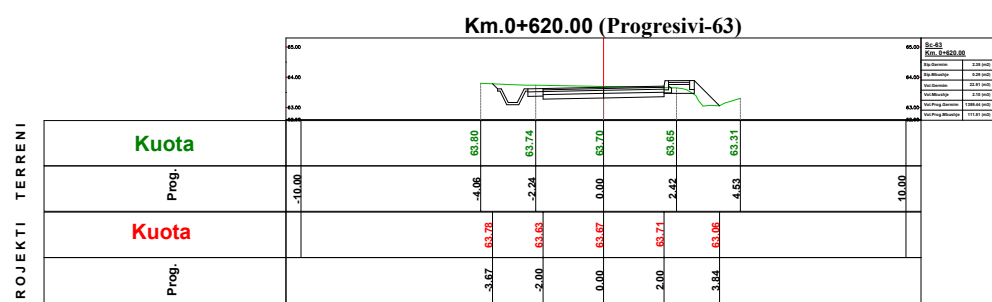
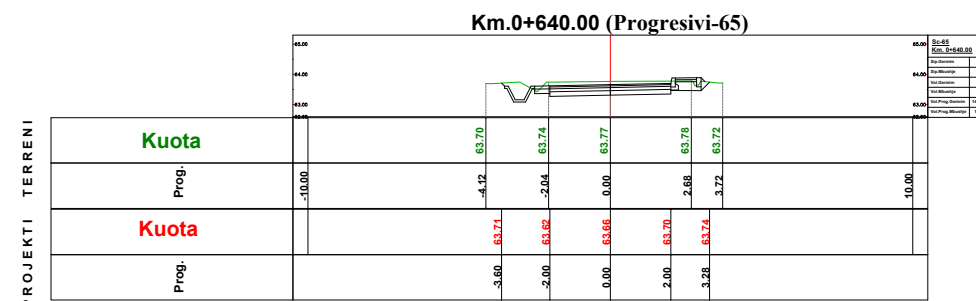
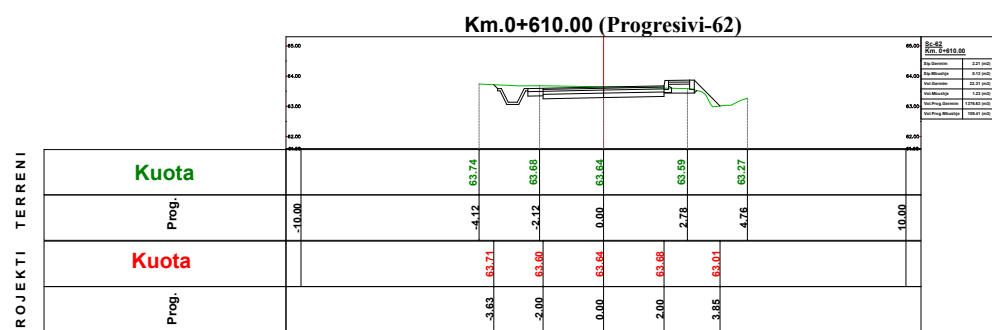
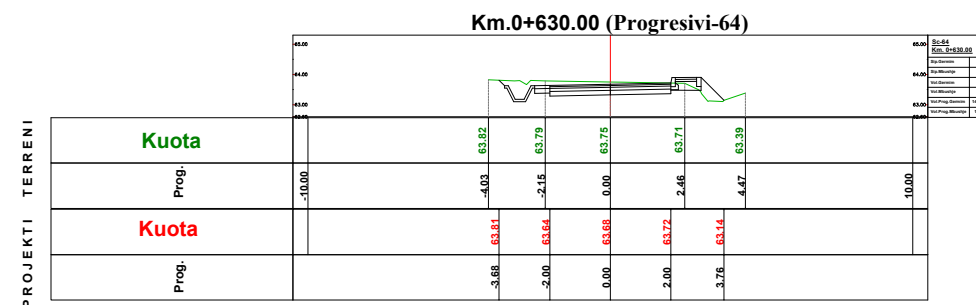
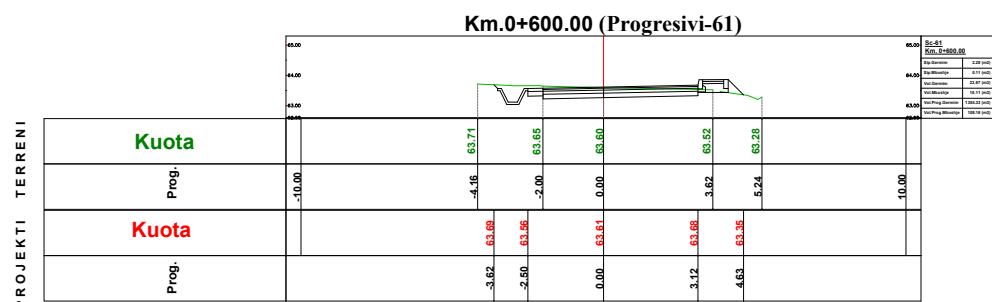



TITULLI I PROJEKTIT

“REHABILITIMI I INFRASTRUKTURËS RRUGORE  
NË NJËSINË ADMINISTRATIVE  
VAQARR - PEZË - NDRIQ”

FAZA

PROJEKT ZBATIM

RRUGA "BREGU I ERZENIT"

EMËRTIMI I FLETËS: SEKSIONET TERTHORE

SHKALLA **1:250**

NUMRI I FLETËS **T-206**

2024

AUTORITETI KONTRAKTOR:  
BASHKIA TIRANË



PROJEKTUESI: "NET-GROUP" SH.P.K

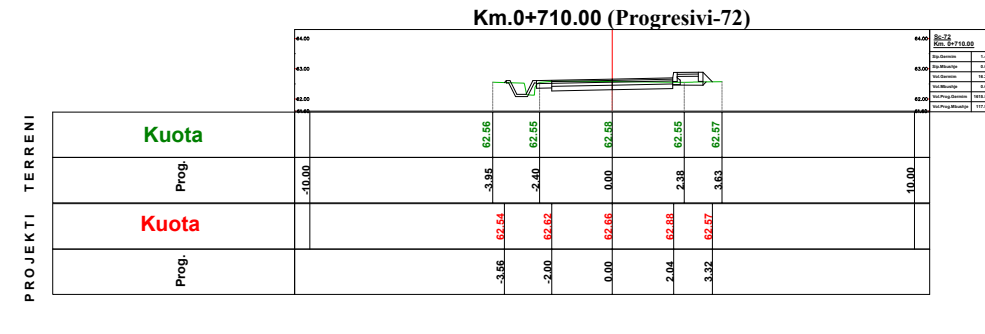
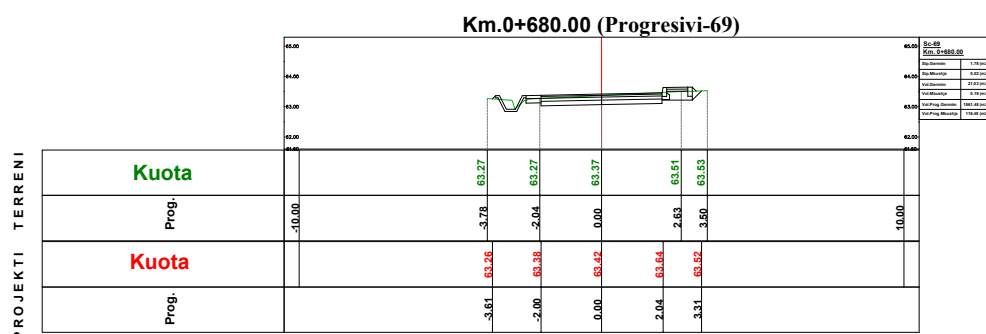
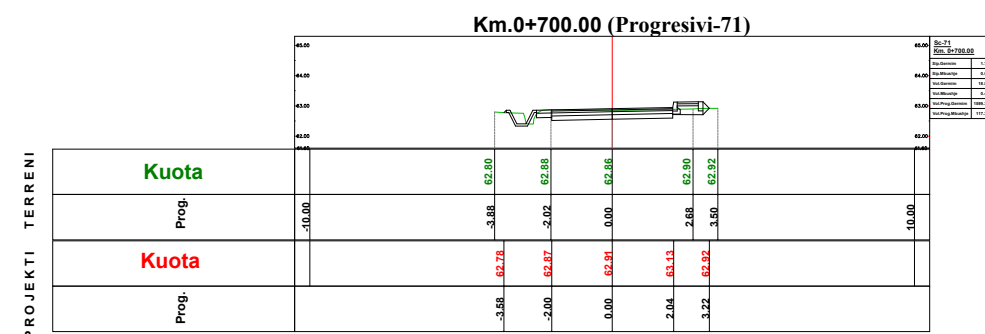
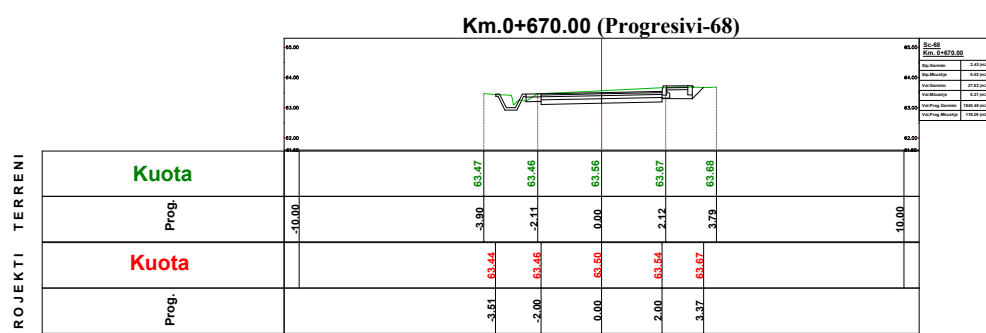
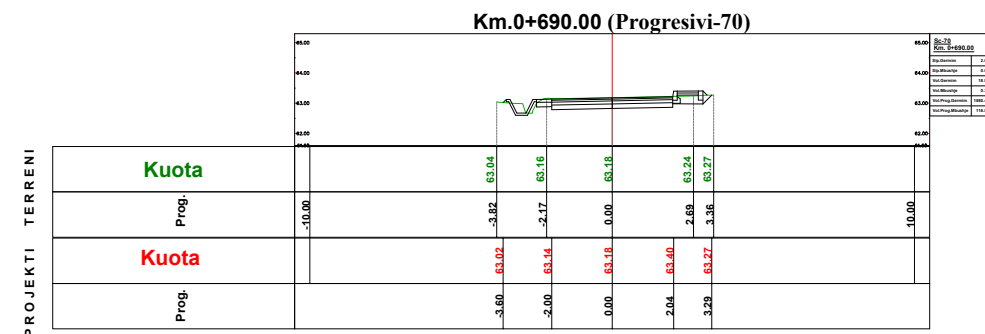
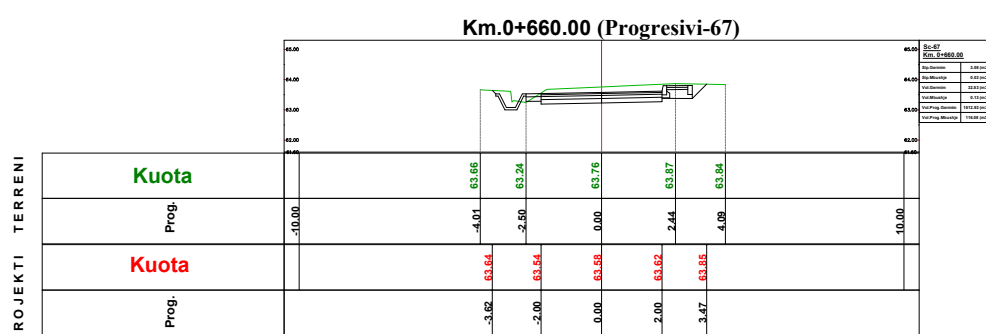

TITULLI I PROJEKTIT

“REHABILITIMI I INFRASTRUKTURËS RRUGORE  
NË NJËSINË ADMINISTRATIVE  
VAQARR - PEZË - NDRQ”

FAZA

PROJEKT ZBATIM

RRUGA "BREGU I ERZENIT"

EMËRTIMI I FLETËS: SEKSIONET TERTHORE

SHKALLA 1:250

NUMRI I FLETËS T-207

2024

AUTORITETI KONTRAKTOR:  
BASHKIA TIRANË



PROJEKTUESI: "NET-GROUP" SH.P.K

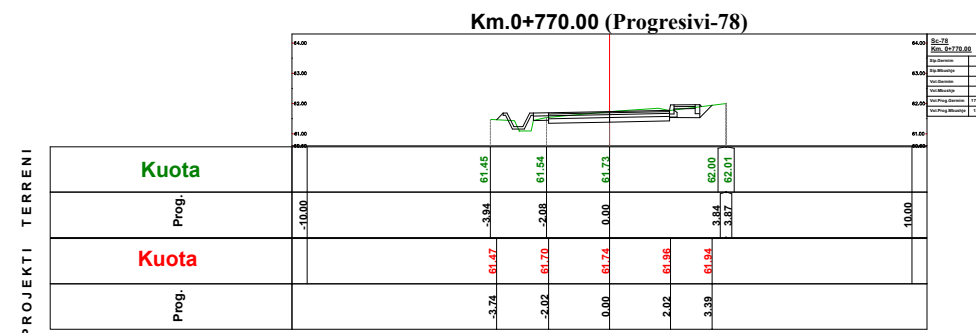
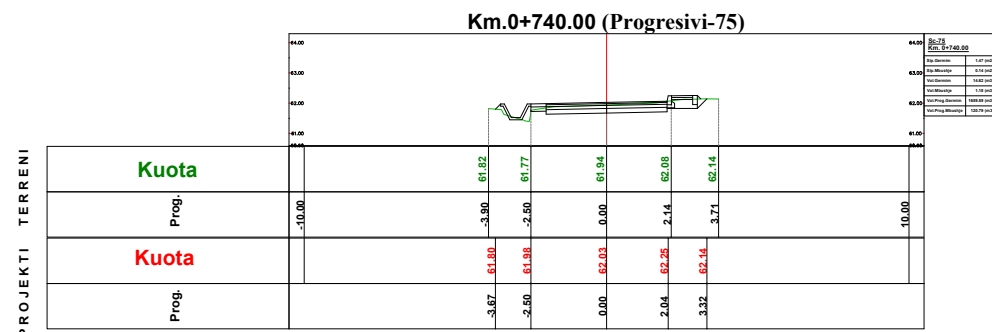
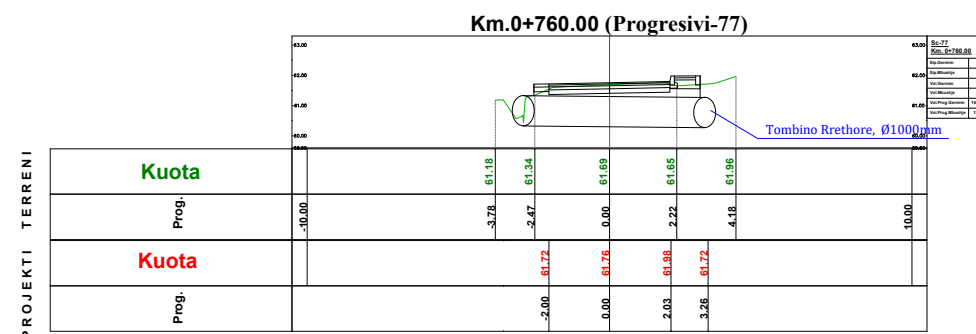
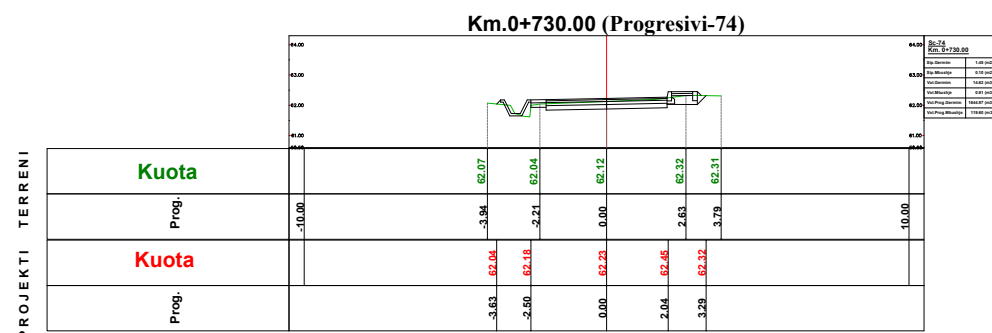
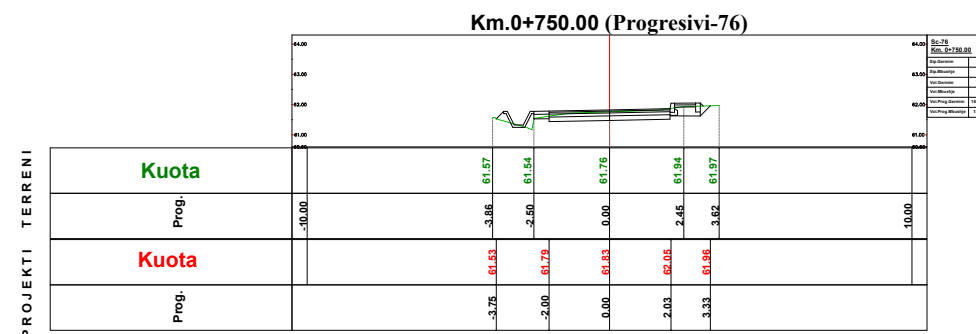
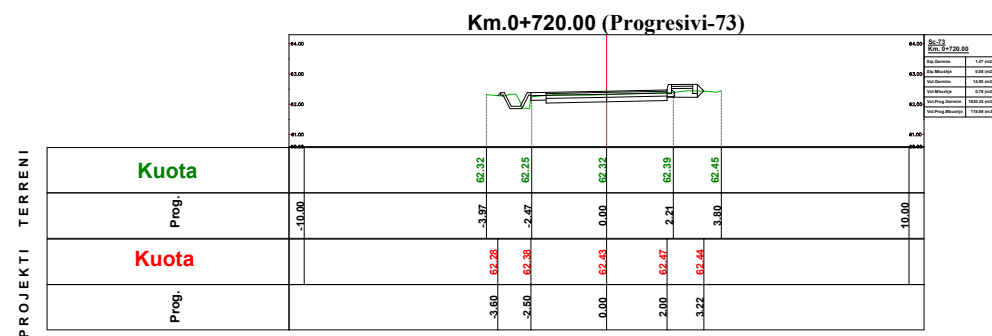

TITULLI I PROJEKTIT

“REHABILITIMI I INFRASTRUKTURËS RRUGORE  
NË NJËSINË ADMINISTRATIVE  
VAQARR - PEZË - NDRROQ”

FAZA

PROJEKT ZBATIM

RRUGA "BREGU I ERZENIT"

EMËRTIMI I FLETËS: SEKSIONET TERTHORE

SHKALLA 1:250

NUMRI I FLETËS T-208

2024

AUTORITETI KONTRAKTOR:  
BASHKIA TIRANË



PROJEKTUESI: "NET-GROUP" SH.P.K

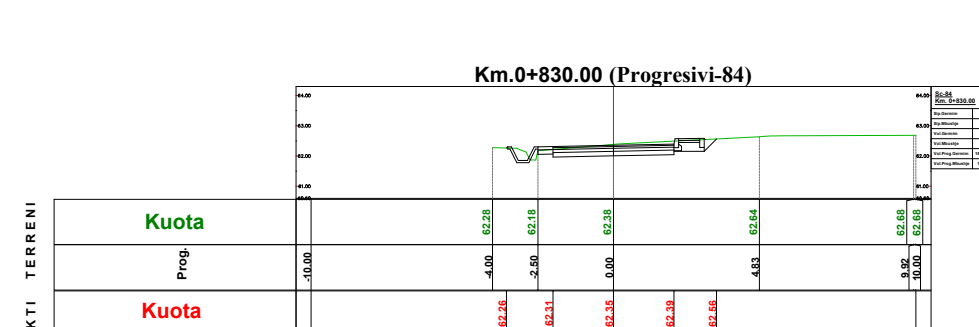
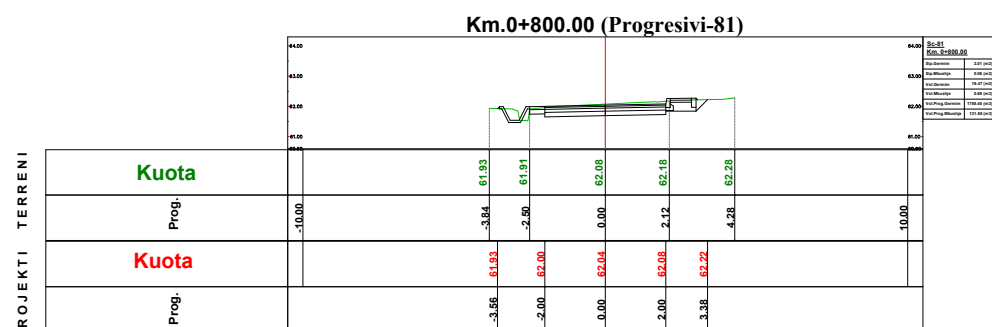
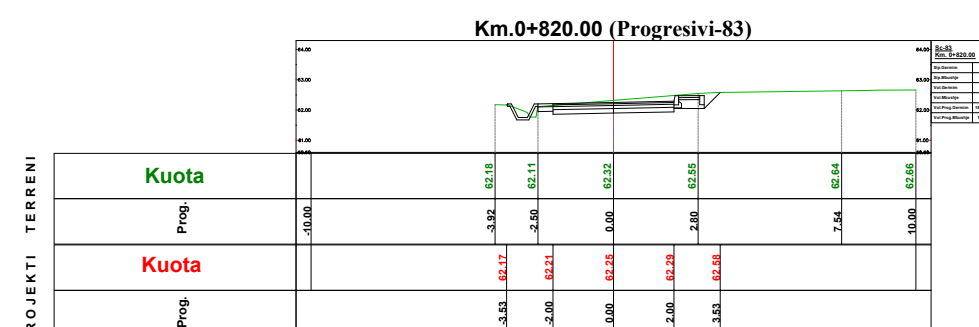
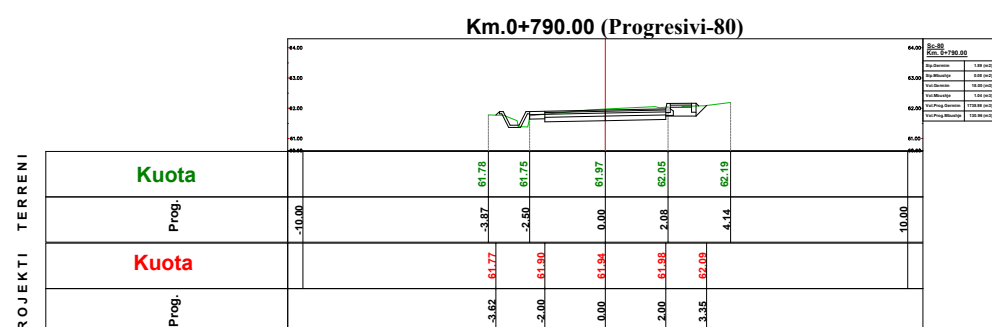
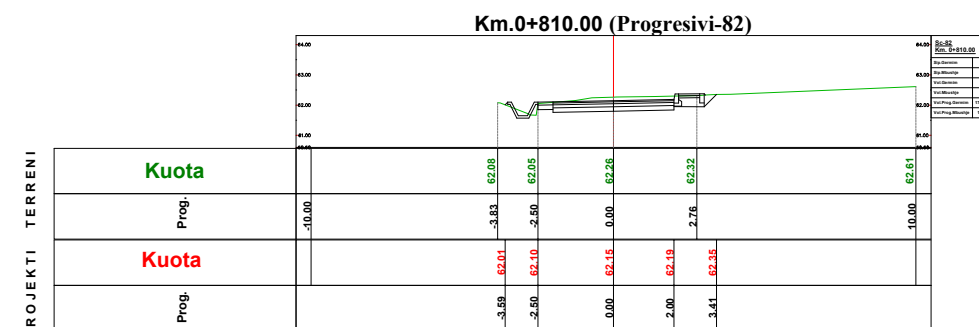
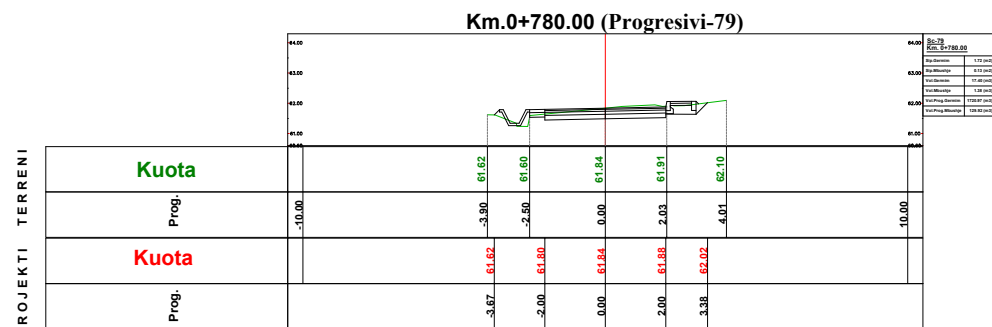

TITULLI I PROJEKTIT

“REHABILITIMI I INFRASTRUKTURËS RRUGORE  
NË NJËSINË ADMINISTRATIVE  
VAQARR - PEZË - NDRROQ”

FAZA

PROJEKT ZBATIM

RRUGA "BREGU I ERZENIT"

EMËRTIMI I FLETËS: SEKSIONET TERTHORE

SHKALLA 1:250

NUMRI I FLETËS T-209

2024

AUTORITETI KONTRAKTOR:  
BASHKIA TIRANË



PROJEKTUESI: "NET-GROUP" SH.P.K



Km.0+840.00 (Progresivi-85)

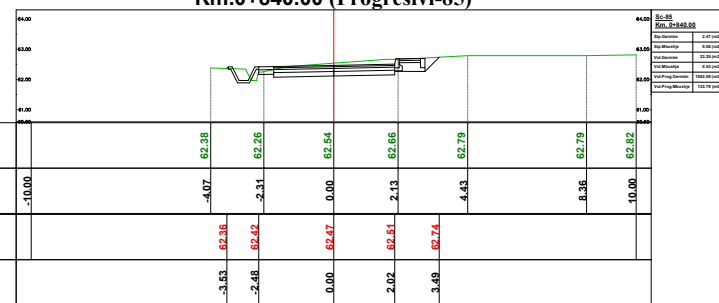

Km.0+870.00 (Progresivi-88)

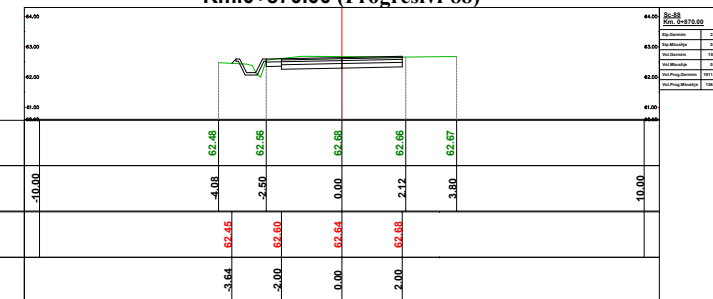

Km.0+850.00 (Progresivi-86)

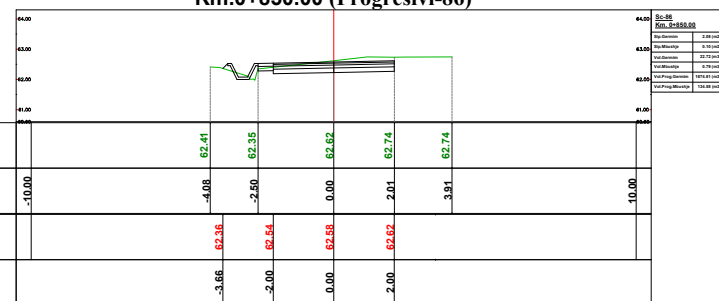

Km.0+880.00 (Progresivi-89)

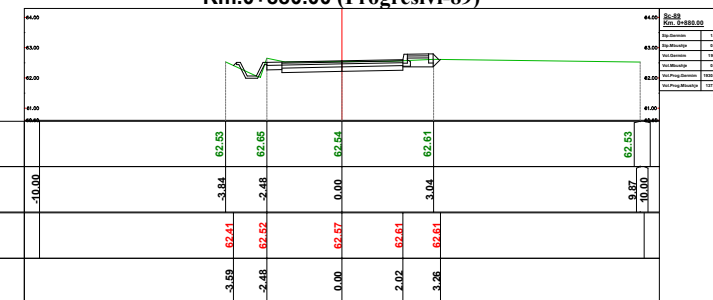

Km.0+860.00 (Progresivi-87)

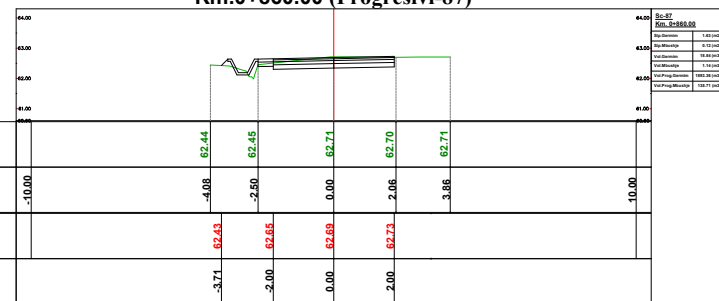

Km.0+890.00 (Progresivi-90)

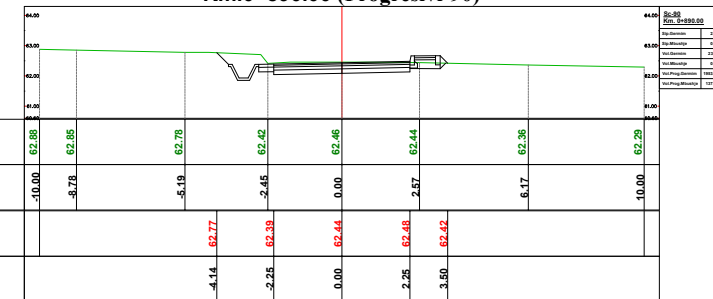

**TITULLI I PROJEKTIT**

“REHABILITIMI I INFRASTRUKTURËS RRUGORE  
NË NJËSINË ADMINISTRATIVE  
VAQARR - PEZË - NDRROQ”

FAZA

**PROJEKT ZBATIM**

**RRUGA "BREGU I ERZENIT"**

EMËRTIMI I FLETËS: TABELA E VOLUMEVE

SHKALLA

NUMRI I FLETËS **T-210**

2024

AUTORITETI KONTRAKTOR:  
BASHKIA TIRANË



PROJEKTUESI: "NET-GROUP" SH.P.K



**Tabela Volumeve**

Progresivi	Sip.Mbushje	Sip.Germim	Vol.Mbushje	Vol.Germim	Vol.Prog.Mbush	Vol.Prog.Germim
0+000.00	0.00	5.86	0.00	0.00	0.00	0.00
0+010.00	0.03	3.12	0.14	44.41	0.14	44.41
0+020.00	0.01	3.41	0.19	32.65	0.33	77.06
0+030.00	0.03	3.23	0.19	33.21	0.52	110.27
0+040.00	0.03	3.10	0.32	31.57	0.84	141.84
0+050.00	0.05	2.86	0.40	29.78	1.24	171.63
0+060.00	0.05	2.57	0.47	27.11	1.71	198.74
0+070.00	0.07	2.21	0.59	23.87	2.30	222.61
0+080.00	0.04	4.77	0.61	42.95	2.91	265.55
0+090.00	0.00	2.79	0.16	44.74	3.06	310.30
0+100.00	0.00	2.09	0.00	24.39	3.07	334.69
0+110.00	0.00	2.18	0.00	21.34	3.07	356.03
0+120.00	0.01	2.04	0.05	21.08	3.12	377.11
0+130.00	0.01	2.22	0.11	21.29	3.23	398.40
0+140.00	0.01	2.38	0.12	23.03	3.35	421.43
0+150.00	0.02	2.11	0.14	22.42	3.49	443.84
0+160.00	0.03	1.75	0.26	19.30	3.75	463.14
0+170.00	0.01	2.12	0.24	19.35	3.98	482.49
0+180.00	0.01	2.16	0.10	21.41	4.08	503.90
0+190.00	0.00	1.67	0.05	18.46	4.14	522.36

**Tabela Volumeve**

Progresivi	Sip.Mbushje	Sip.Germim	Vol.Mbushje	Vol.Germim	Vol.Prog.Mbush	Vol.Prog.Germim
0+200.00	0.14	1.44	0.63	15.44	4.76	537.81
0+210.00	0.08	1.75	1.10	15.90	5.87	553.71
0+220.00	0.01	1.82	0.45	17.85	6.31	571.55
0+230.00	0.05	2.56	0.30	21.92	6.61	593.48
0+240.00	0.00	2.23	0.25	23.99	6.86	617.46
0+250.00	0.00	2.22	0.01	22.26	6.87	639.73
0+260.00	0.00	2.24	0.01	22.30	6.89	662.02
0+270.00	0.00	2.37	0.03	23.07	6.91	685.09
0+280.00	0.07	1.91	0.38	21.36	7.29	706.46
0+290.00	0.14	1.71	1.04	18.08	8.34	724.54
0+300.00	0.10	1.72	1.17	17.12	9.51	741.66
0+310.00	0.12	1.70	1.10	17.12	10.61	758.78
0+320.00	0.13	1.69	1.23	16.95	11.84	775.73
0+330.00	0.13	1.69	1.28	16.87	13.12	792.60
0+340.00	0.10	1.71	1.16	17.02	14.28	809.62
0+350.00	0.07	1.76	0.85	17.36	15.13	826.98
0+360.00	0.03	2.18	0.49	19.66	15.62	846.65
0+370.00	0.01	2.52	0.20	23.49	15.82	870.13
0+380.00	0.00	2.69	0.08	26.04	15.90	896.17
0+390.00	0.01	2.78	0.05	27.34	15.96	923.51

**Tabela Volumeve**

Progresivi	Sip.Mbushje	Sip.Germim	Vol.Mbushje	Vol.Germim	Vol.Prog.Mbush	Vol.Prog.Germim
0+400.00	0.01	2.52	0.07	26.52	16.03	950.03
0+410.00	0.01	2.27	0.11	23.96	16.14	973.99
0+420.00	0.04	2.19	0.28	22.30	16.42	996.29
0+430.00	0.01	2.49	0.26	23.39	16.68	1019.68
0+440.00	0.06	2.05	0.35	22.74	17.03	1042.42
0+450.00	0.18	1.81	1.30	18.88	18.34	1061.30
0+460.00	0.19	1.65	1.91	17.20	20.24	1078.50
0+470.00	0.11	1.61	1.55	16.20	21.80	1094.70
0+480.00	0.10	1.84	1.07	17.18	22.86	1111.88
0+490.00	0.07	2.16	0.84	19.90	23.70	1131.78
0+500.00	0.04	2.01	0.51	21.02	24.21	1152.81
0+510.00	0.11	2.16	0.76	20.81	24.97	1173.61
0+520.00	0.23	2.20	1.74	21.70	26.71	1195.32
0+530.00	0.38	2.00	3.12	20.81	29.83	1216.13
0+540.00	0.34	1.76	3.64	18.73	33.47	1234.86
0+550.00	0.31	1.88	3.29	18.15	36.75	1253.00
0+560.00	0.01	1.94	1.81	18.47	38.57	1271.47
0+570.00	4.58	1.32	28.18	15.77	66.74	1287.24
0+580.00	0.00	2.40	21.77	18.74	88.51	1305.98
0+590.00	1.91	2.49	9.56	24.48	98.07	1330.46

**Tabela Volumeve**

Progresivi	Sip.Mbushje	Sip.Germim	Vol.Mbushje	Vol.Germim	Vol.Prog.Mbush	Vol.Prog.Germim
0+600.00	0.11	2.28	10.11	23.87	108.18	1354.33
0+610.00	0.13	2.21	1.23	22.31	109.41	1376.63
0+620.00	0.29	2.35	2.10	22.81	111.51	1399.44
0+630.00	0.28	2.59	3.00	24.46	114.51	1423.91
0+640.00	0.00	2.67	1.42	26.30	115.93	1450.21
0+650.00	0.00	3.43	0.02	30.20	115.95	1480.40
0+660.00	0.03	3.08	0.13	32.53	116.08	1512.93
0+670.00	0.02	2.43	0.21	27.52	116.29	1540.45
0+680.00	0.02	1.78	0.19	21.03	116.48	1561.48
0+690.00	0.05	2.02	0.36	18.96	116.84	1580.44
0+700.00	0.05	1.76	0.47	18.88	117.31	1599.32
0+710.00	0.08	1.49	0.60	16.22	117.91	1615.55
0+720.00	0.08	1.47	0.78	14.80	118.69	1630.35
0+730.00	0.10	1.45	0.91	14.62	119.60	1644.97
0+740.00	0.14	1.47	1.18	14.62	120.79	1659.59
0+750.00	0.16	1.54	1.50	15.05	122.29	1674.64
0+760.00	0.45	1.26	3.26	13.83	125.55	1688.47
0+770.00	0.15	1.76	2.99	15.11	128.54	1703.57
0+780.00	0.13	1.72	1.38	17.40	129.92	1720.97
0+790.00	0.08	1.89	1.04	18.00	130.96	1738.98

**Tabela Volumeve**

Progresivi	Sip.Mbushje	Sip.Germim	Vol.Mbushje	Vol.Germim	Vol.Prog.Mbush	Vol.Prog.Germim
0+800.00	0.06	2.01	0.69	19.47	131.65	1758.45
0+810.00	0.06	2.41	0.59	22.07	132.24	1780.52
0+820.00	0.05	2.54	0.53	24.72	132.77	1805.24
0+830.00	0.05	2.18	0.49	23.60	133.26	1828.84
0+840.00	0.06	2.47	0.53	23.25	133.79	1852.09
0+850.00	0.10	2.08	0.79	22.72	134.58	1874.81
0+860.00	0.12	1.63	1.14	18.54	135.71	1893.36
0+870.00	0.07	2.00	0.95	18.15	136.67	1911.51
0+880.00	0.04	1.81	0.51	19.02	137.18	1930.53
0+890.00	0.00	2.83	0.19	23.19	137.37	1953.72

# TITULLI I PROJEKTIT

“REHABILITIMI I INFRASTRUKTURËS RRUGORE  
NË NJËSINË ADMINISTRATIVE  
VAQARR - PEZË - NDRQO”

FAZA

PROJEKT ZBATIM

RRUGA E BURGUT

EMËRTIMI I FLETËS PLANIMETRIA K.U.N

SHKALLA **1:2000**

NUMRI I FLETËS **T-211**

2024

AUTORITETI KONTRAKTOR:  
BASHKIA TIRANË



PROJEKTUESI: “NET-GROUP” SH.P.K

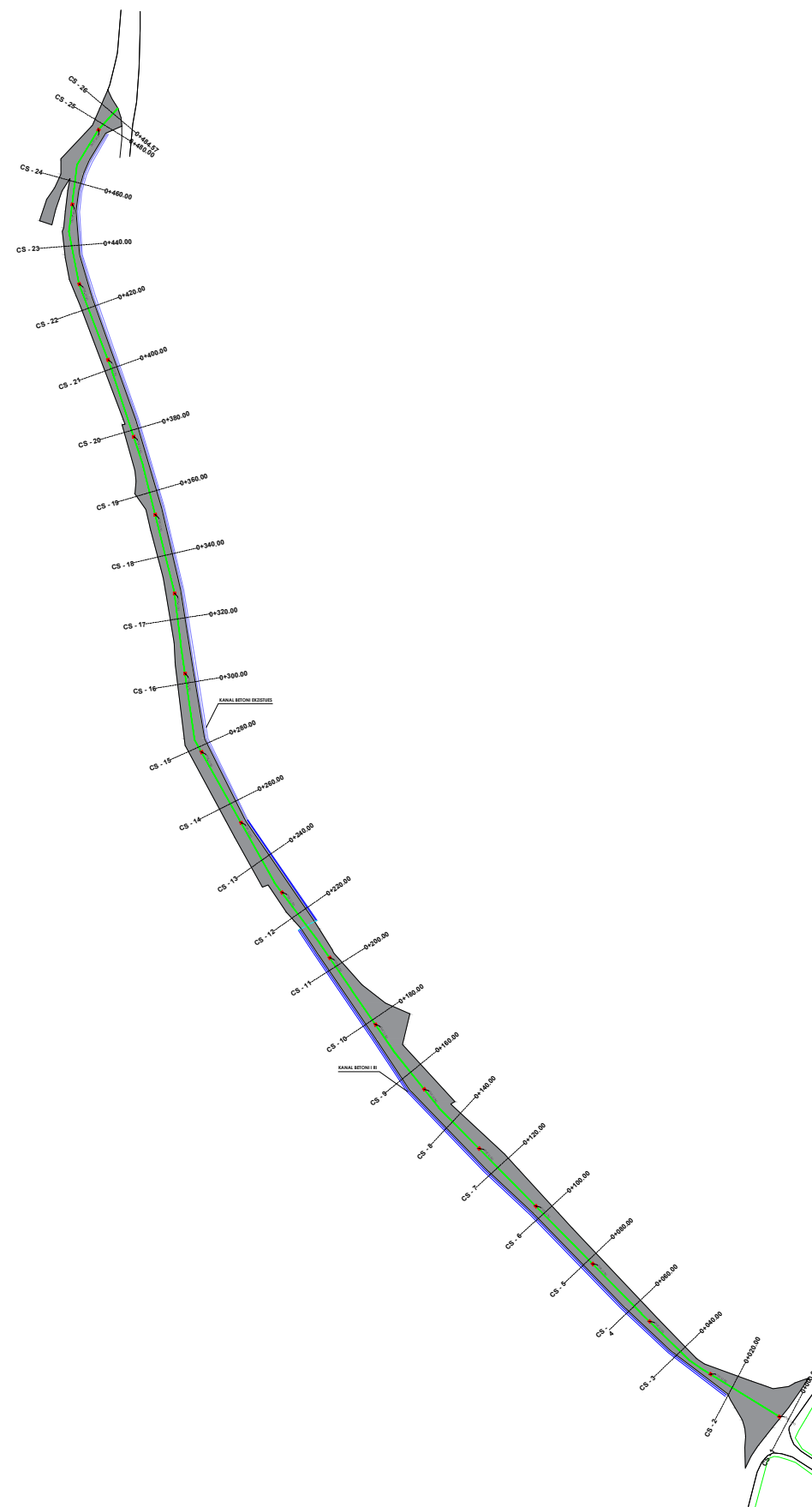

## LEGJENDA

- SIPËRFAQE ME ASFALT
- KUNETË
- TROTUAR
- BANKINË
- MUR I RI
- KANAL I RI
- KANAL EKZISTUES
- GARDH I RI
- TUB I RI
- PUSETË K.U.N
- LINJË K.U.N

AL BETONI I RI

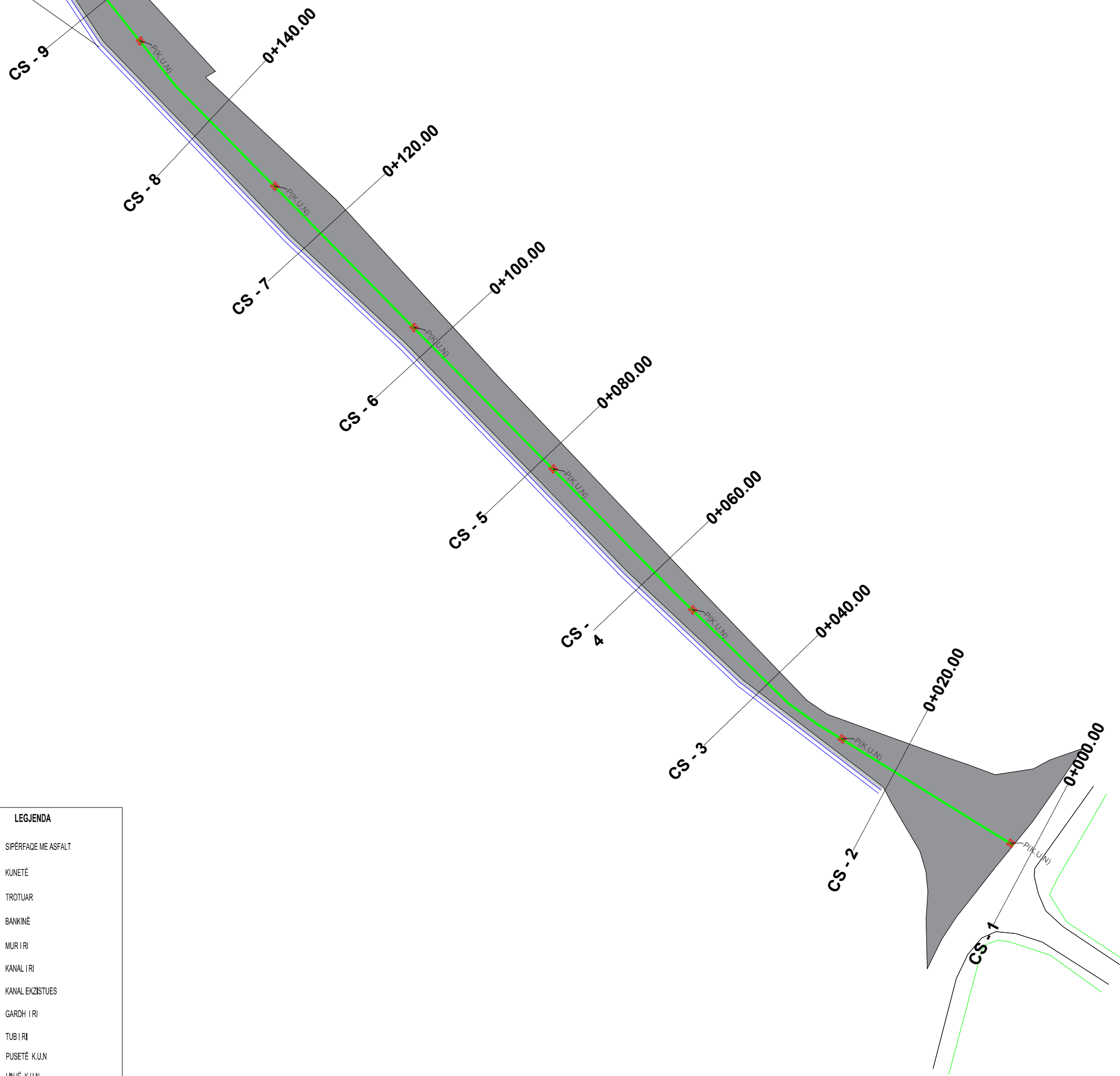

LEGJENDA

-  SIPERFAQE ME ASFALT
-  KUNETË
-  TROTUAR
-  BANKINË
-  MUR I RI
-  KANAL I RI
-  KANAL EKZISTUES
-  GARDH I RI
-  TUB I RI
-  PUSËTË K.U.N
-  LINJË K.U.N

TITULLI I PROJEKTIT

“REHABILITIMI I INFRASTRUKTURËS RRUGORE NË NJËSINË ADMINISTRATIVE VAQARR - PEZË - NDRIQ”

FAZA

PROJEKT ZBATIM

RRUGA E BURGUT

EMËRTIMI I FLETËS PLANIMETRIK.U.N

SHKALLA 1:500

NUMRI I FLETËS T-212

2024

AUTORITETI KONTRAKTOR:  
BASHKIA TIRANË



PROJEKTUESI: “NET-GROUP” SH.P.K



# TITULLI I PROJEKTIT

“REHABILITIMI I INFRASTRUKTURËS RRUGORE  
NË NJËSINË ADMINISTRATIVE  
VAQARR - PEZË - NDROQ”

FAZA

PROJEKT ZBATIM

RRUGA E BURGUT

EMËRTIMI I FLETËS PLANIMETRIA K.U.N

SHKALLA 1:500

NUMRI I FLETËS T-213

2024

AUTORITETI KONTRAKTOR:  
BASHKIA TIRANË



PROJEKTUESI: "NET-GROUP" SH.P.K

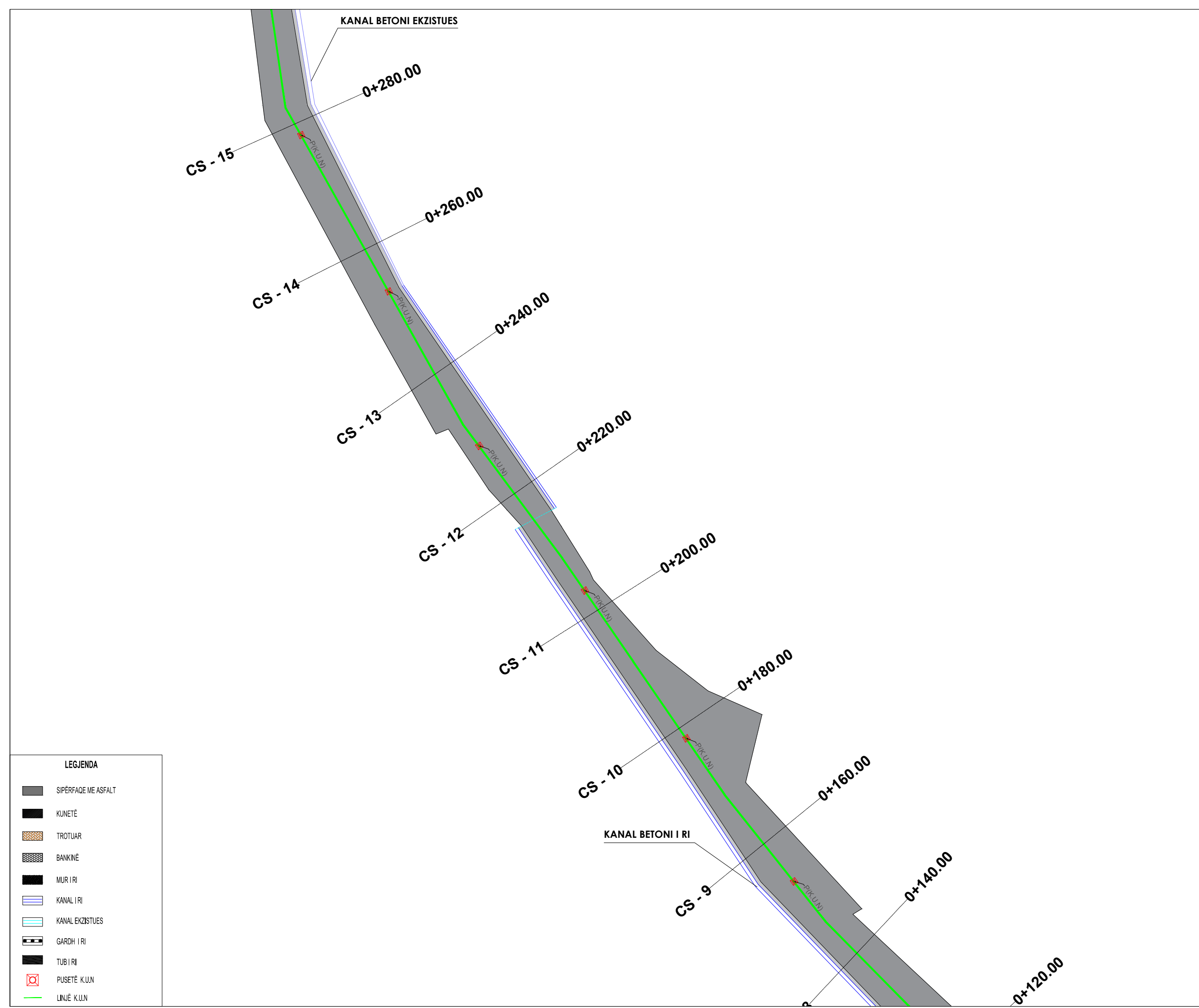



TITULLI I PROJEKTIT

“REHABILITIMI I INFRASTRUKTURËS RRUGORE  
NË NJËSINË ADMINISTRATIVE  
VAQARR - PEZË - NDROQ”

FAZA

PROJEKT ZBATIM

RRUGA E BURGUT

EMËRTIMI I FLETËS PLANIMETRIK UJUN

SHKALLA 1:500

NUMRI I FLETËS T-214

2024

AUTORITETI KONTRAKTOR:  
BASHKIA TIRANË



PROJEKTUESI: “NET-GROUP” SH.P.K



LEGJENDA

- SIPËRFAQE ME ASFALT
- KUNETË
- TROTUAR
- BANKINË
- MUR I RI
- KANAL I RI
- KANAL EKZISTUES
- GARDH I RI
- TUB I RI
- PUSETË K.U.N
- LINJË K.U.N

# TITULLI I PROJEKTIT

“REHABILITIMI I INFRASTRUKTURËS RRUGORE  
NË NJËSINË ADMINISTRATIVE  
VAQARR - PEZË - NDROQ”

FAZA

PROJEKT ZBATIM

RRUGA E BURGUT

EMËRTIMI I FLETËS PLANIMETRIA K.U.N

SHKALLA 1:500

NUMRI I FLETËS T-215

2024

AUTORITETI KONTRAKTOR:  
BASHKIA TIRANË



PROJEKTUESI: “NET-GROUP” SH.P.K

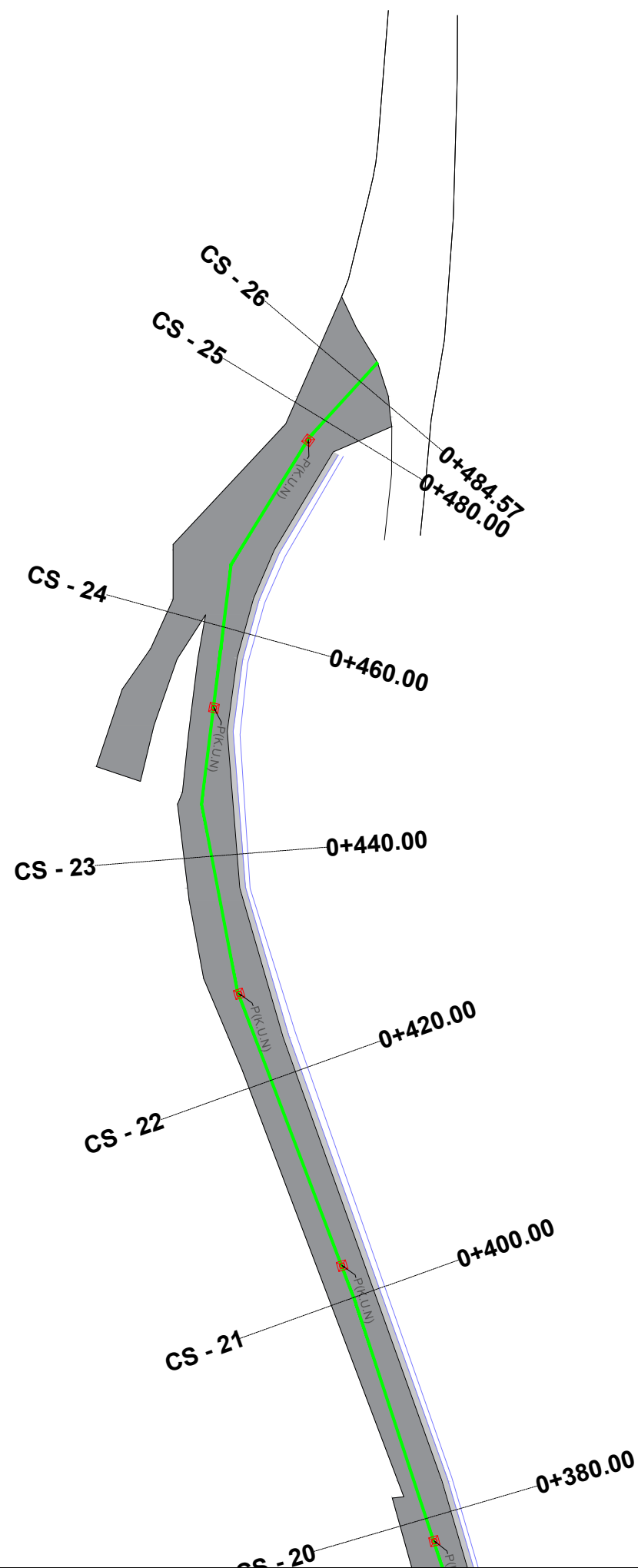

## LEGJENDA

- SIPËRFAQE ME ASFALT
- KUNETË
- TROTUAR
- BANKINË
- MUR I RI
- KANAL I RI
- KANAL EKZISTUES
- GARDH I RI
- TUB I RI
- PUSETË K.U.N
- LINJË K.U.N

**TITULLI I PROJEKTIT**

“REHABILITIMI I INFRASTRUKTURËS RRUGORE  
NË NJËSINË ADMINISTRATIVE  
VAQARR - PEZË - NDROQ”

FAZA

**PROJEKT ZBATIM**

**RRUGA E FSHATIT MËNIK**

EMËRTIMI I FLETËS PLANIMETRIA K.U.N

SHKALLA **1:5000**

NUMRI I FLETËS **T-216**

2024

AUTORITETI KONTRAKTOR:  
BASHKIA TIRANË



PROJEKTUESI: “NET-GROUP” SH.P.K

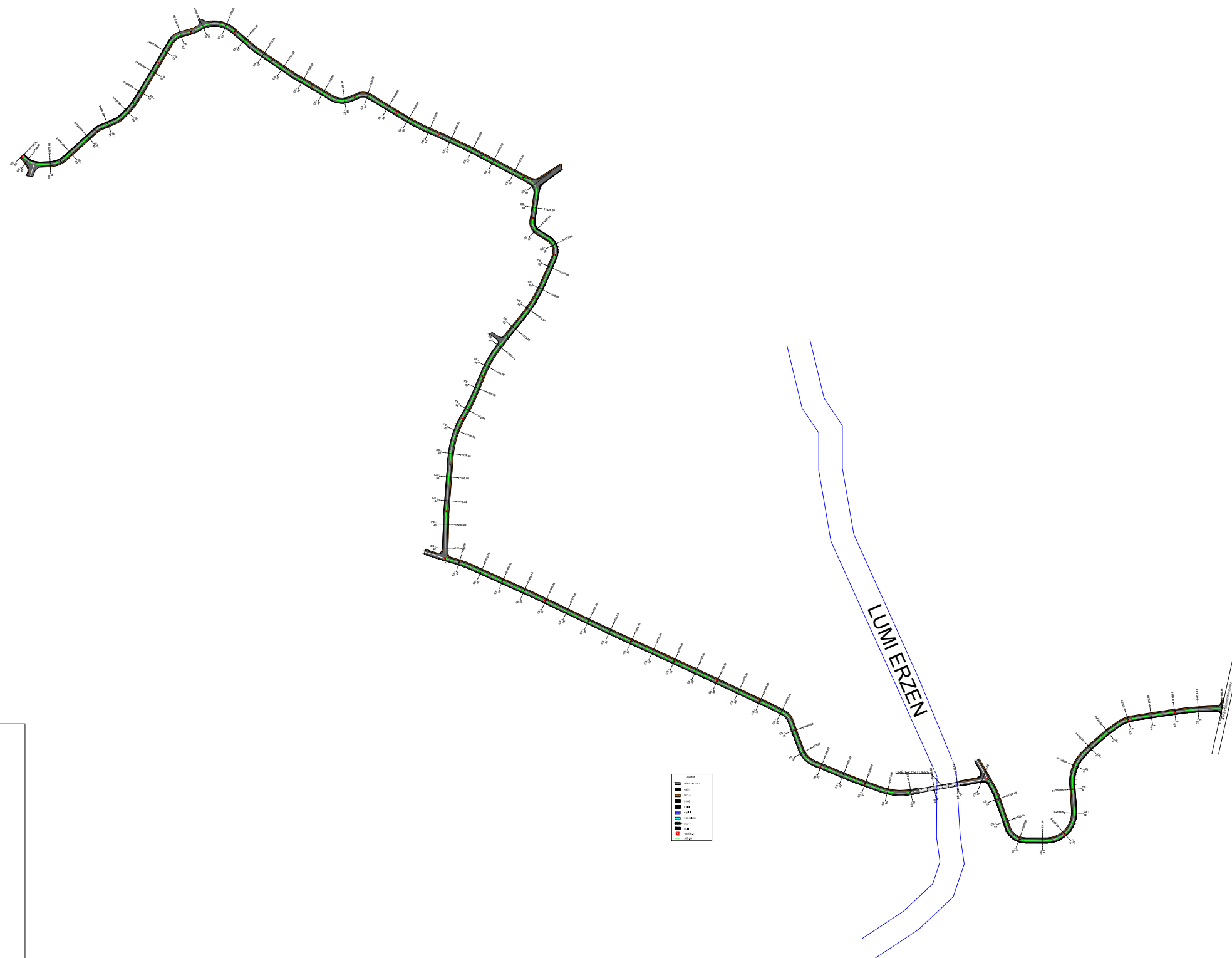

**LEGJENDA**

-  SIPËRFAQE ME ASFALT
-  KUNETË
-  TROTUAR
-  BANKINË
-  MUR I RI
-  KANAL I RI
-  KANAL EKZISTUES
-  GARDH I RI
-  TUB I RI
-  PUSËTË K.U.N
-  LINJË K.U.N

TITULLI I PROJEKTIT

“REHABILITIMI I INFRASTRUKTURËS RRUGORE  
NË NJËSINË ADMINISTRATIVE  
VAQARR - PEZË - NDROQ”

FAZA

PROJEKT ZBATIM

RRUGA E FSHATIT MËNIK

EMËRTIMI I FLETËS PLANIMETRIA K.U.N

SHKALLA 1:500

NUMRI I FLETËS T-217

2024

AUTORITETI KONTRAKTOR:  
BASHKIA TIRANË



PROJEKTUESI: “NET-GROUP” SH.P.K

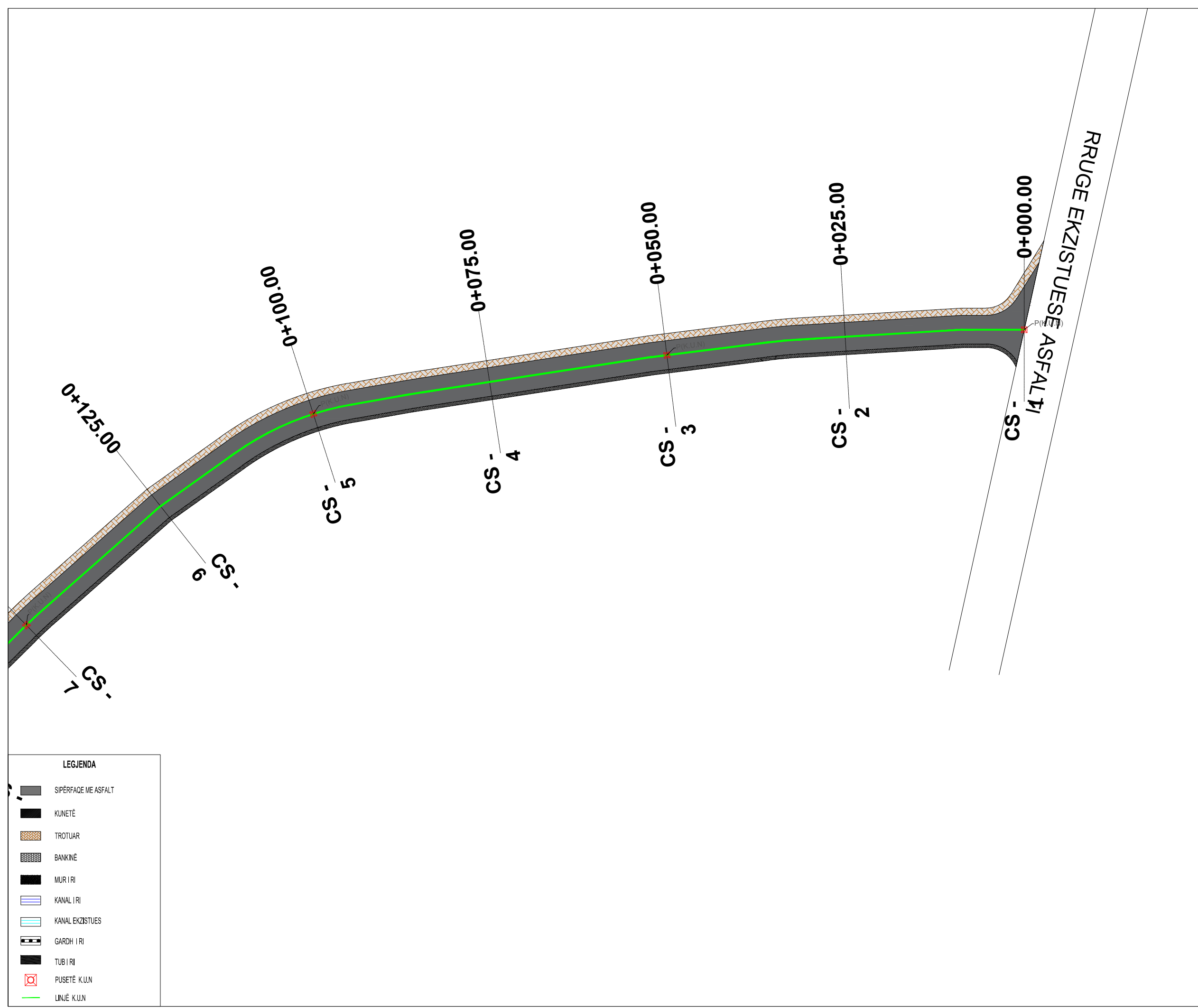

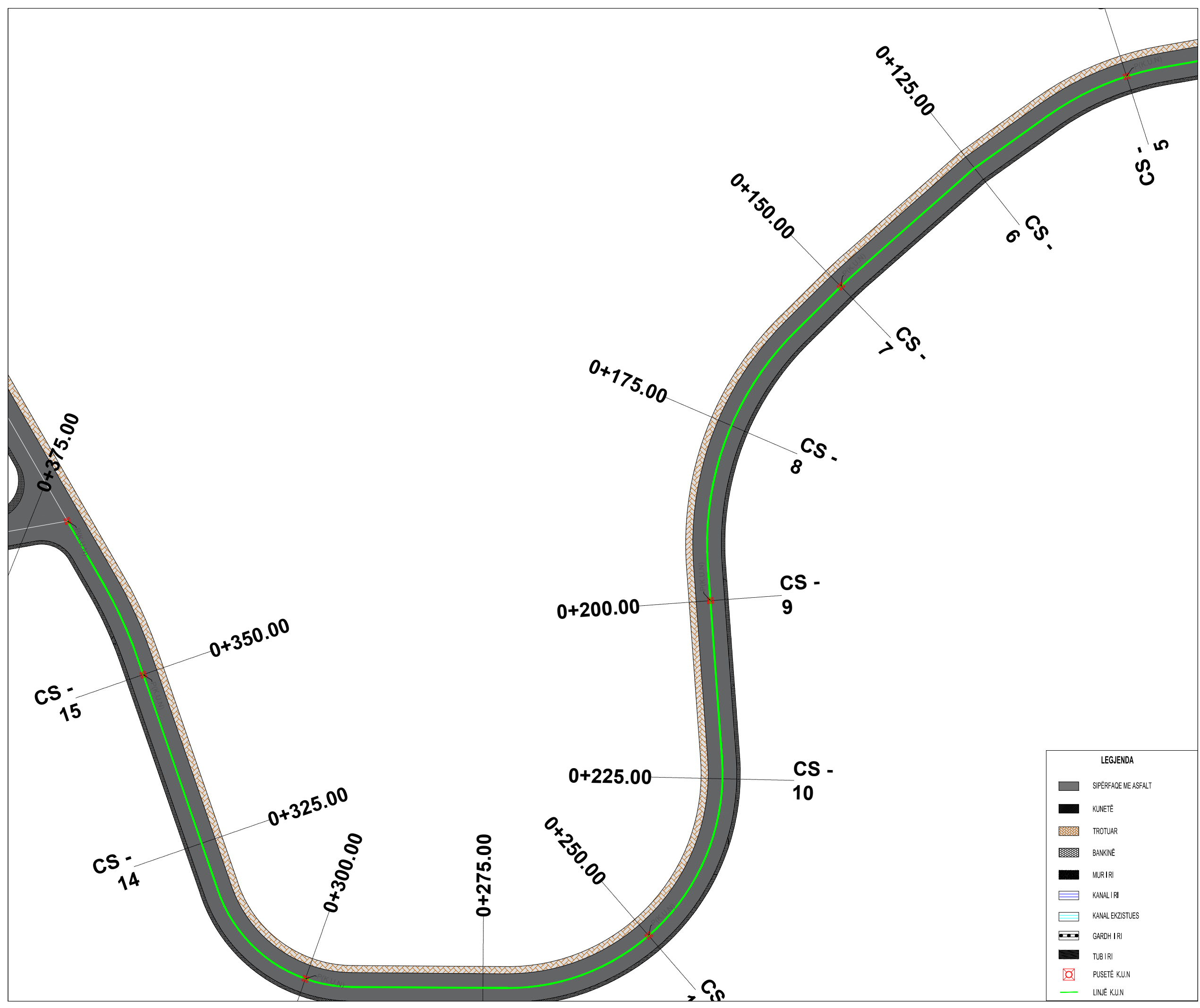

**LEGJENDA**

	SIPËRFAQE ME ASFALT
	KUNETË
	TROTUAR
	BANKINË
	MUR I RI
	KANAL I RI
	KANAL EKZISTUES
	GARDH I RI
	TUB I RI
	PUSETË K.U.N
	LINJË K.U.N

**TITULLI I PROJEKTIT**

“REHABILITIMI I INFRASTRUKTURËS RRUGORE NË NJËSINË ADMINISTRATIVE VAQARR - PEZË - NDROQ”

---

FAZA

**PROJEKT ZBATIM**

---

**RRUGA E FSHATIT MËNIK**

---

EMËRTIMI I FLETËS PLANIMETRIA K.U.N

SHKALLA **1:500**

NUMRI I FLETËS **T-218**

2024

AUTORITETI KONTRAKTOR:

BASHKIA TIRANË



BASHKIA TIRANË

---

PROJEKTUESI: “NET-GROUP” SH.P.K



NET-GROUP

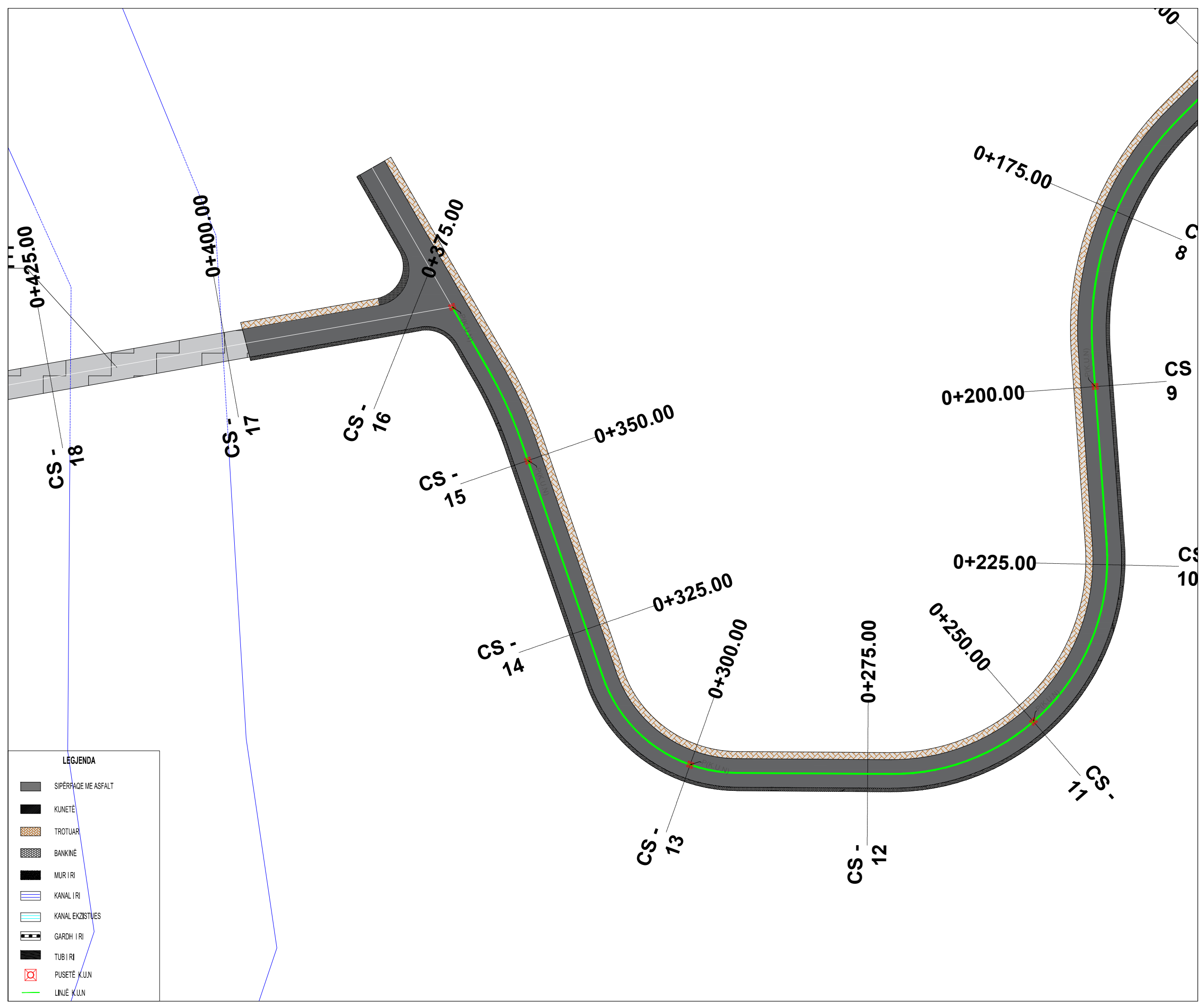

**LEGJENDA**

	SIPËRFAQE ME ASFALT
	KUNETË
	TROTUAR
	BANKINË
	MUR I RI
	KANAL I RI
	KANAL EKZISTUES
	GARDH I RI
	TUB I RI
	PUSETË K.U.N
	LINJË K.U.N

**TITULLI I PROJEKTIT**

“REHABILITIMI I INFRASTRUKTURËS RRUGORE  
NË NJËSINË ADMINISTRATIVE  
VAQARR - PEZË - NDRUQ”

FAZA

PROJEKT ZBATIM

**RRUGA E FSHATIT MËNIK**

EMËRTIMI I FLETËS PLANIMETRIA K.U.N

SHKALLA **1:500**

NUMRI I FLETËS **T-219**

2024

AUTORITETI KONTRAKTOR:  
BASHKIA TIRANË



PROJEKTUESI: “NET-GROUP” SH.P.K



TITULLI I PROJEKTIT

“REHABILITIMI I INFRASTRUKTURËS RRUGORE  
NË NJËSINË ADMINISTRATIVE  
VAQARR - PEZË - NDROQ”

FAZA

PROJEKT ZBATIM

RRUGA E FSHATIT MËNIK

EMËRTIMI I FLETËS PLANIMETRIA K.U.N

SHKALLA 1:500

NUMRI I FLETËS T-220

2024

AUTORITETI KONTRAKTOR:  
BASHKIA TIRANË



PROJEKTUESI: “NET-GROUP” SH.P.K



LEGJENDA

- SIPËRFAQE ME ASFALT
- KUNETË
- TROTUAR
- BANKINË
- MUR I RI
- KANAL I RI
- KANAL EKZISTUES
- GARDH I RI
- TUB I RI
- PUSËTË K.U.N
- LINJË K.U.N

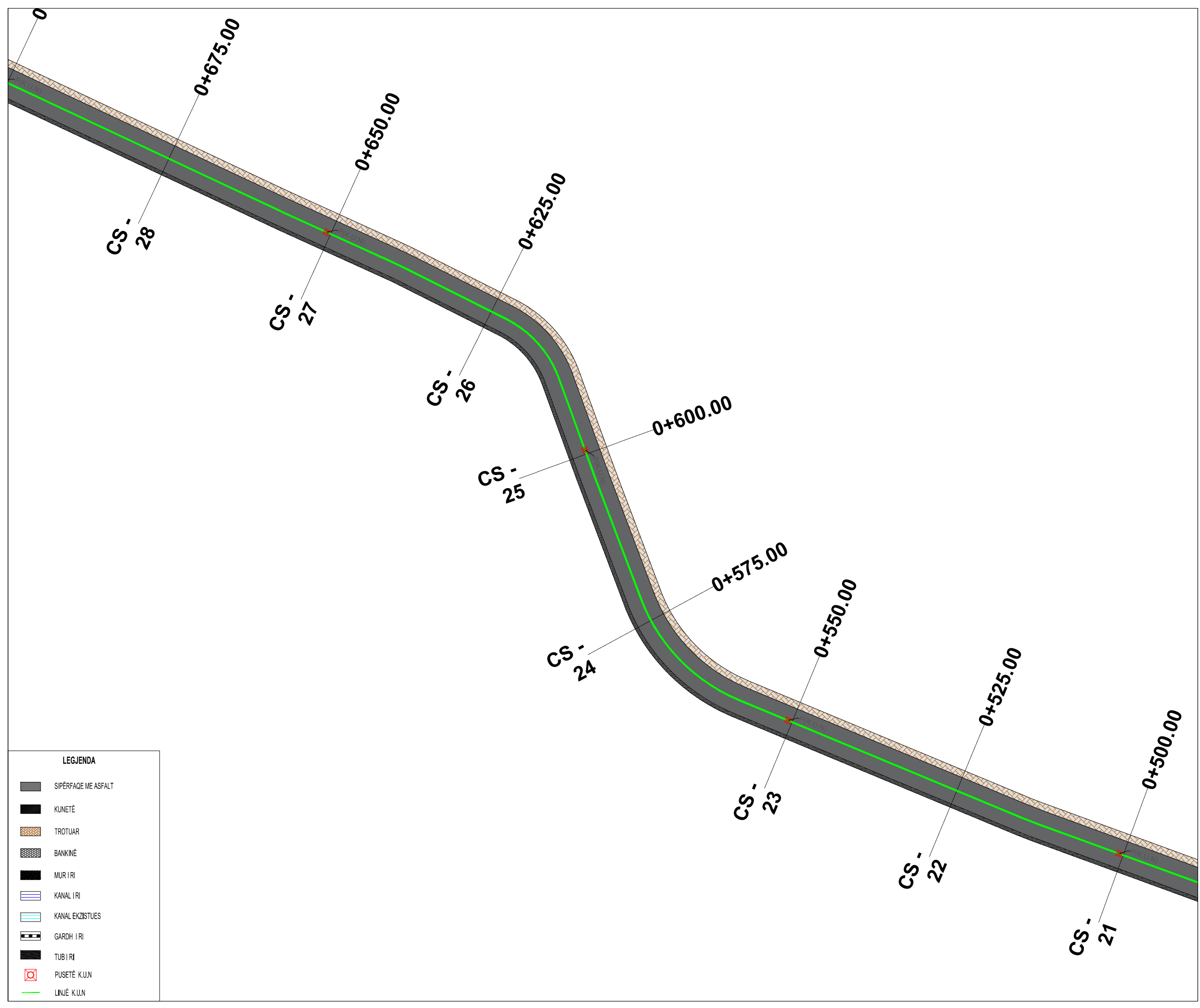

**LEGJENDA**

	SIPERFAQE ME ASFALT
	KUNETË
	TROTUAR
	BANKINË
	MUR I RI
	KANAL I RI
	KANAL EKZISTUES
	GARDH I RI
	TUB I RI
	PUSETË K.U.N
	LINJË K.U.N

**TITULLI I PROJEKTIT**

“REHABILITIMI I INFRASTRUKTURËS RRUGORE NË NJËSINË ADMINISTRATIVE VAQARR - PEZË - NDRIQ”

---

FAZA

**PROJEKT ZBATIM**

---

**RRUGA E FSHATIT MËNIK**

---

EMËRTIMI I FLETËS PLANIMETRIA K.U.N

SHKALLA **1:500**

NUMRI I FLETËS **T-221**

2024

AUTORITETI KONTRAKTOR:

BASHKIA TIRANË



BASHKIA TIRANË

---

PROJEKTUESI: “NET-GROUP” SH.P.K



NET-GROUP



TITULLI I PROJEKTIT

“REHABILITIMI I INFRASTRUKTURËS RRUGORE  
NË NJËSINË ADMINISTRATIVE  
VAQARR - PEZË - NDROQ”

FAZA

PROJEKT ZBATIM

RRUGA E FSHATIT MËNIK

EMËRTIMI I FLETËS PLANIMETRIA K.U.N

SHKALLA 1:500

NUMRI I FLETËS T-222

2024

AUTORITETI KONTRAKTOR:  
BASHKIA TIRANË



PROJEKTUESI: "NET-GROUP" SH.P.K

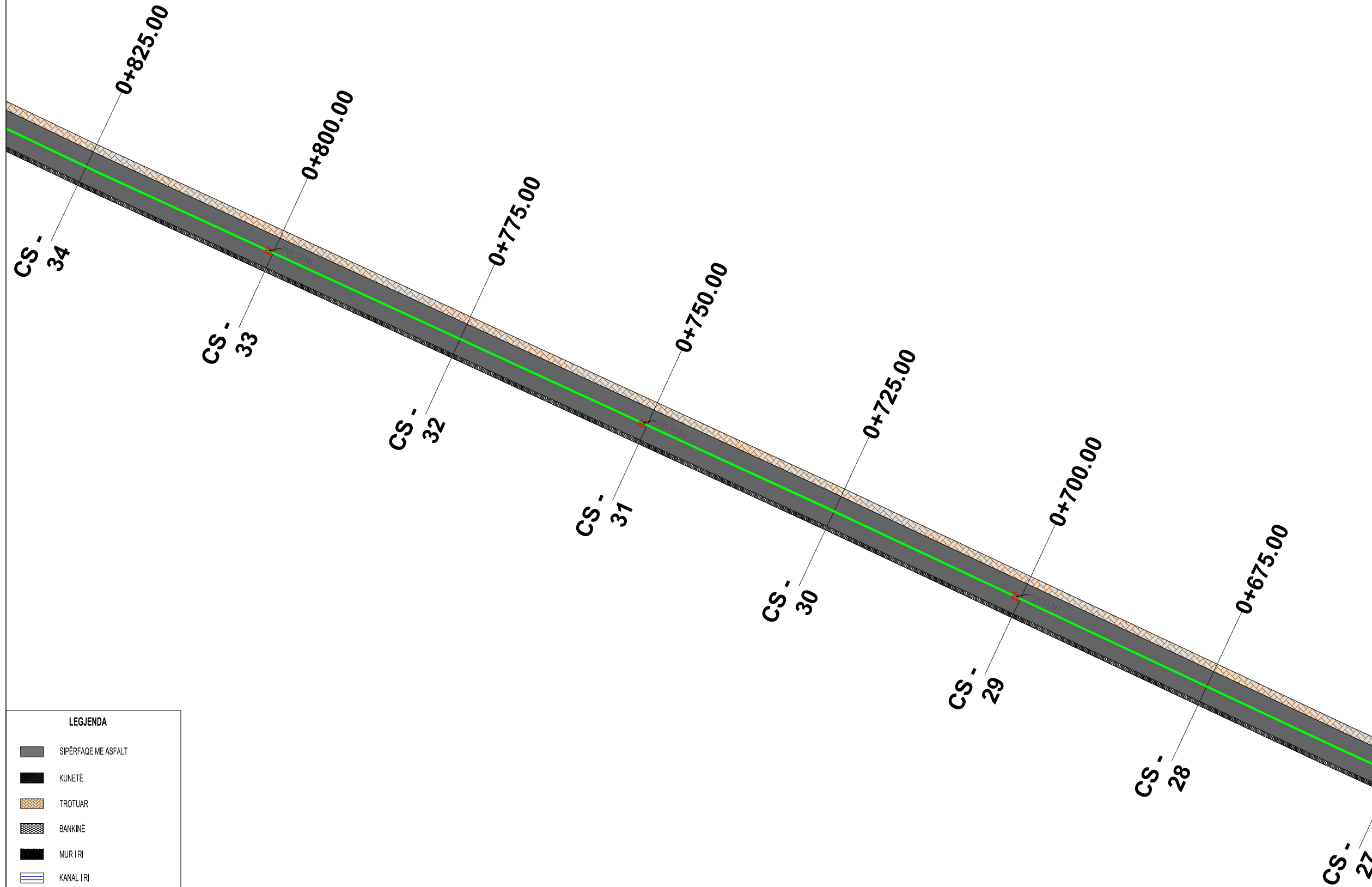

LEGJENDA

- SIPËRFAQE ME ASFALT
- KUNETË
- TROTUAR
- BANKINË
- MUR I RI
- KANAL I RI
- KANAL EKZISTUES
- GARDH I RI
- TUB I RI
- PUSETË K.U.N
- LINJË K.U.N

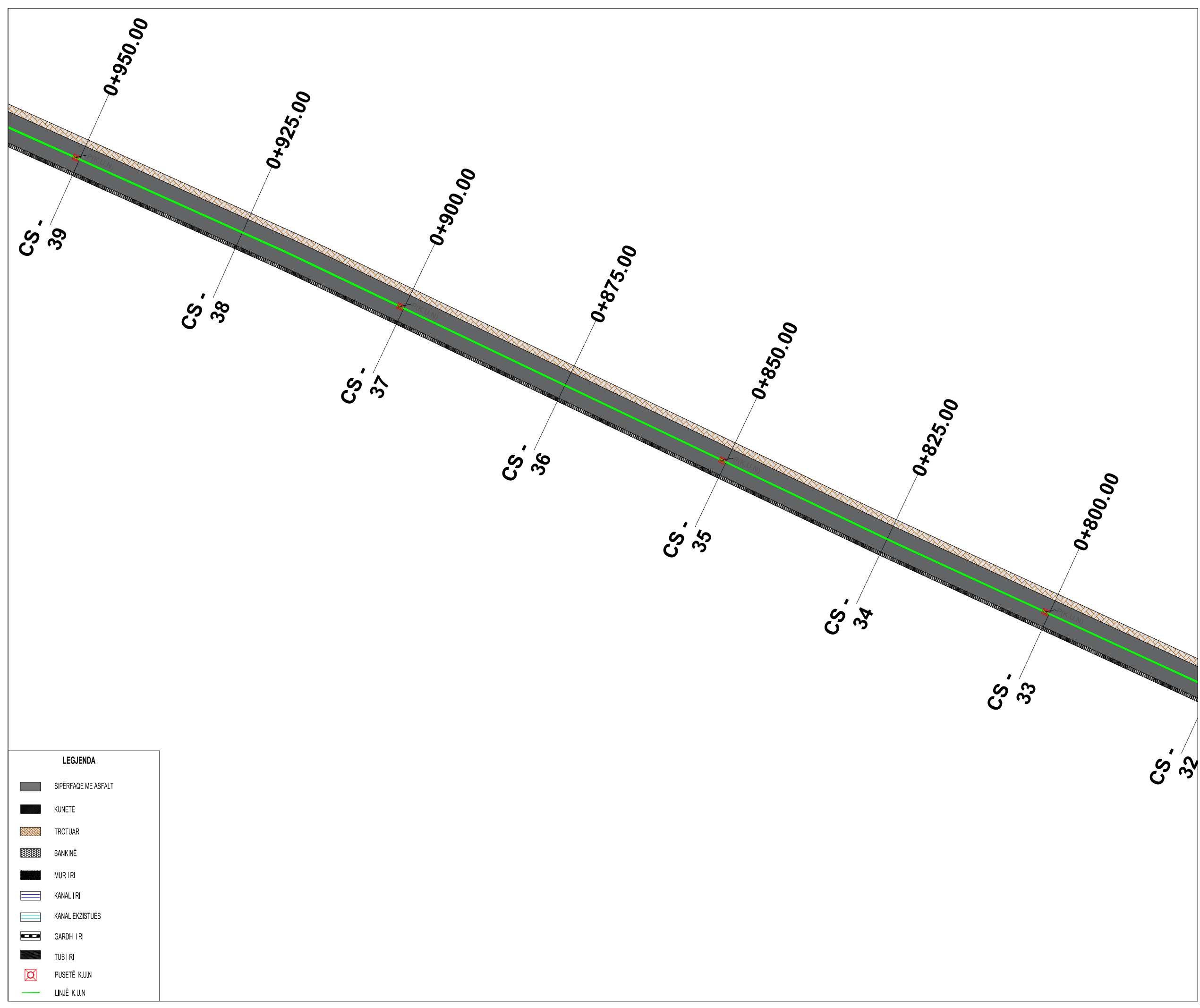

**TITULLI I PROJEKTIT**

“REHABILITIMI I INFRASTRUKTURËS RRUGORE  
NË NJËSINË ADMINISTRATIVE  
VAQARR - PEZË - NDROQ”

FAZA

PROJEKT ZBATIM

**RRUGA E FSHATIT MËNIK**

EMËRTIMI I FLETËS PLANIMETRIA K.U.N

SHKALLA **1:500**

NUMRI I FLETËS **T-223**

2024

**LEGJENDA**

	SIPËRFAQE ME ASFALT
	KUNETË
	TROTUAR
	BANKINË
	MUR I RI
	KANAL I RI
	KANAL EKZISTUES
	GARDH I RI
	TUB I RI
	PUSETË K.U.N
	LINJË K.U.N

AUTORITETI KONTRAKTOR:  
BASHKIA TIRANË



PROJEKTUESI: "NET-GROUP" SH.P.K



TITULLI I PROJEKTIT

“REHABILITIMI I INFRASTRUKTURËS RRUGORE  
NË NJËSINË ADMINISTRATIVE  
VAQARR - PEZË - NDROQ”

FAZA

PROJEKT ZBATIM

RRUGA E FSHATIT MËNIK

EMËRTIMI I FLETËS PLANIMETRIA K.U.N

SHKALLA 1:500

NUMRI I FLETËS T-224

2024

AUTORITETI KONTRAKTOR:  
BASHKIA TIRANË



PROJEKTUESI: “NET-GROUP” SH.P.K

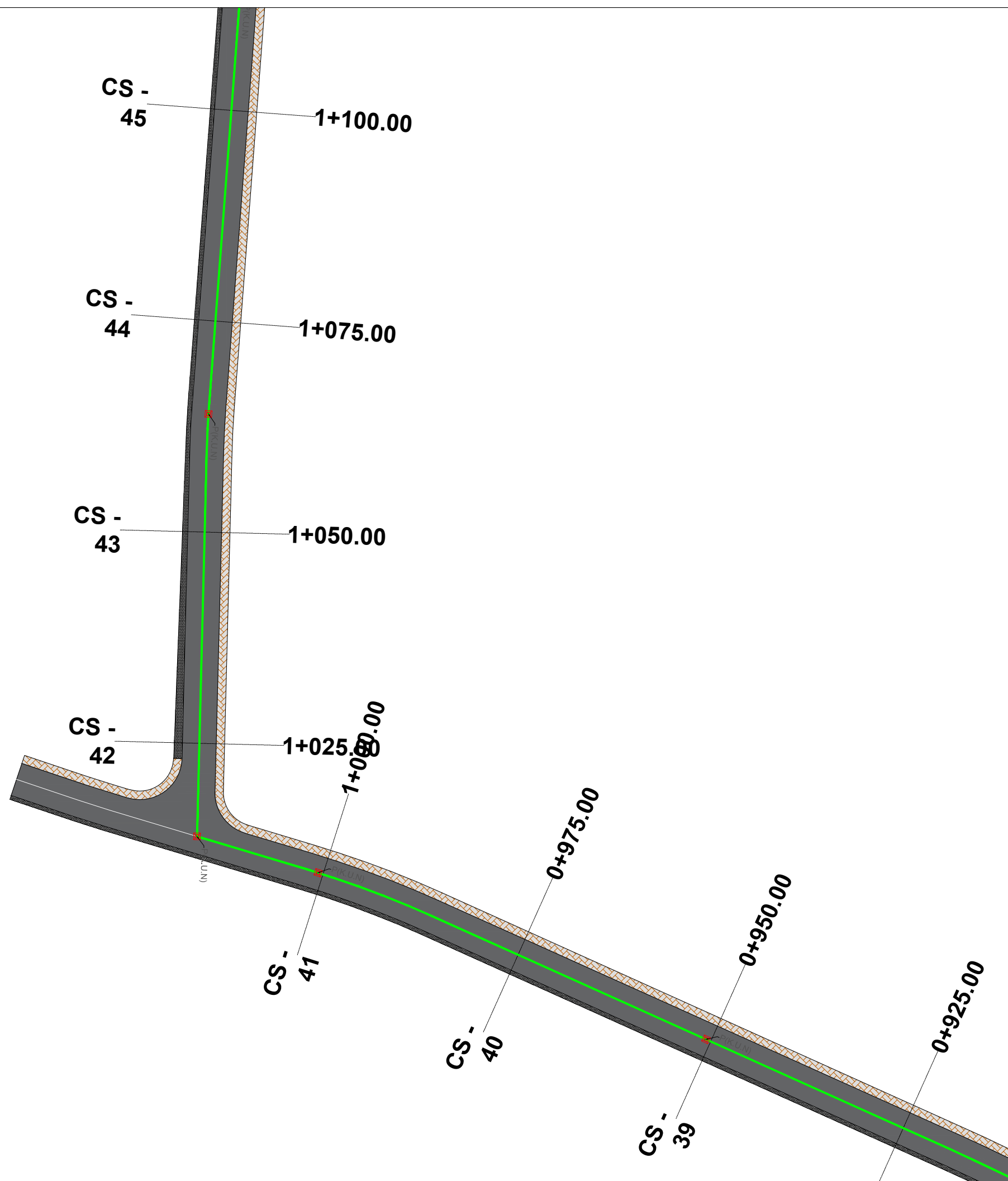

LEGJENDA

- SIPËRFAQE ME ASFALT
- KUNETË
- TROTUAR
- BANKINË
- MUR I RI
- KANAL I RI
- KANAL EKZISTUES
- GARDH I RI
- TUB I RI
- PUSETË K.U.N
- LINJË K.U.N

TITULLI I PROJEKTIT

“REHABILITIMI I INFRASTRUKTURËS RRUGORE  
NË NJËSINË ADMINISTRATIVE  
VAQARR - PEZË - NDRUQ”

FAZA

PROJEKT ZBATIM

RRUGA E FSHATIT MËNIK

EMËRTIMI I FLETËS PLANIMETRIA K.U.N

SHKALLA 1:500

NUMRI I FLETËS T-225

2024

AUTORITETI KONTRAKTOR:  
BASHKIA TIRANË



PROJEKTUESI: “NET-GROUP” SH.P.K

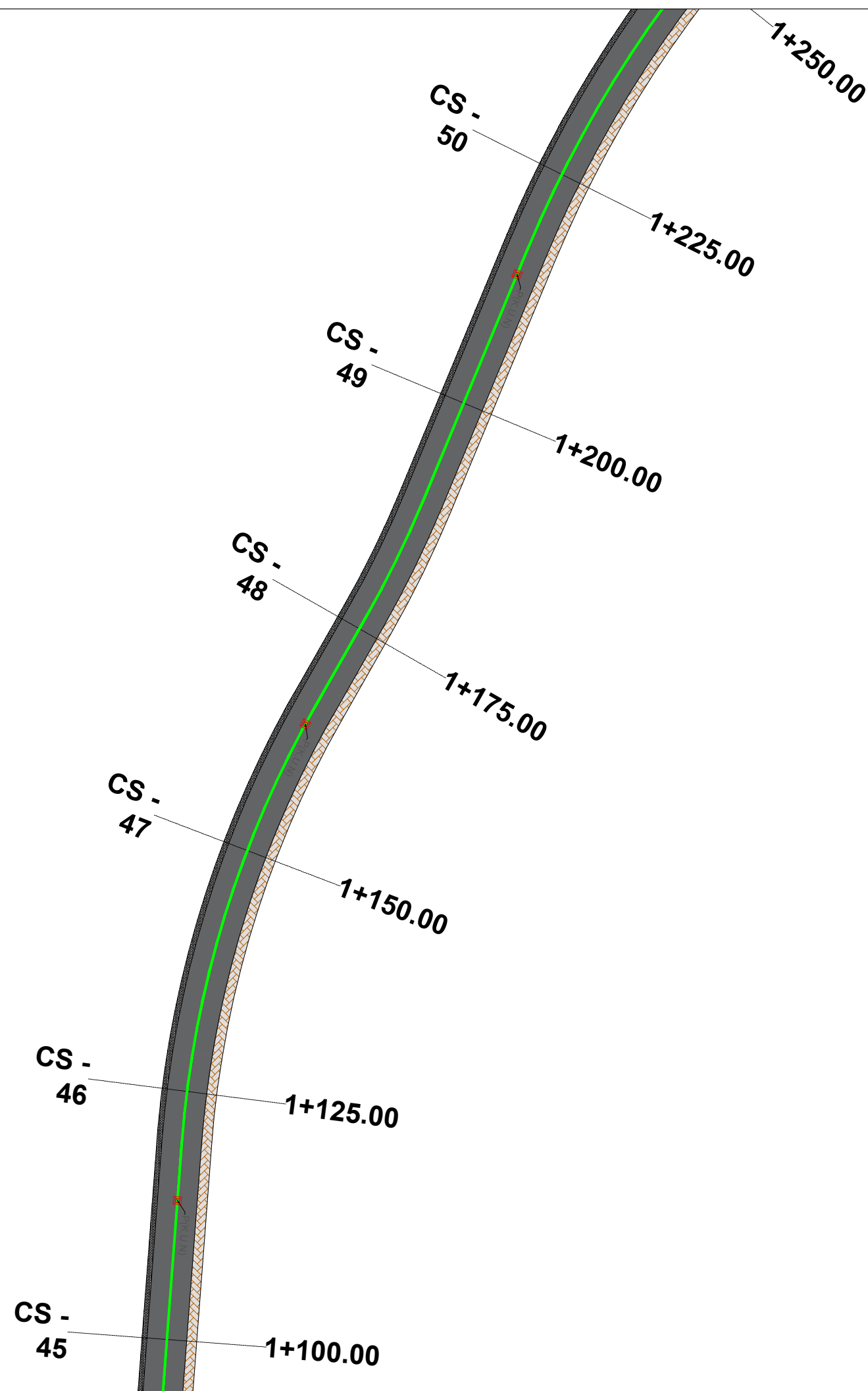

LEGJENDA

- SIPËRFAQE ME ASFALT
- KUNETË
- TROTUAR
- BANKINË
- MUR I RI
- KANAL I RI
- KANAL EKZISTUES
- GARDH I RI
- TUB I RI
- PUSETË K.U.N
- LINJË K.U.N

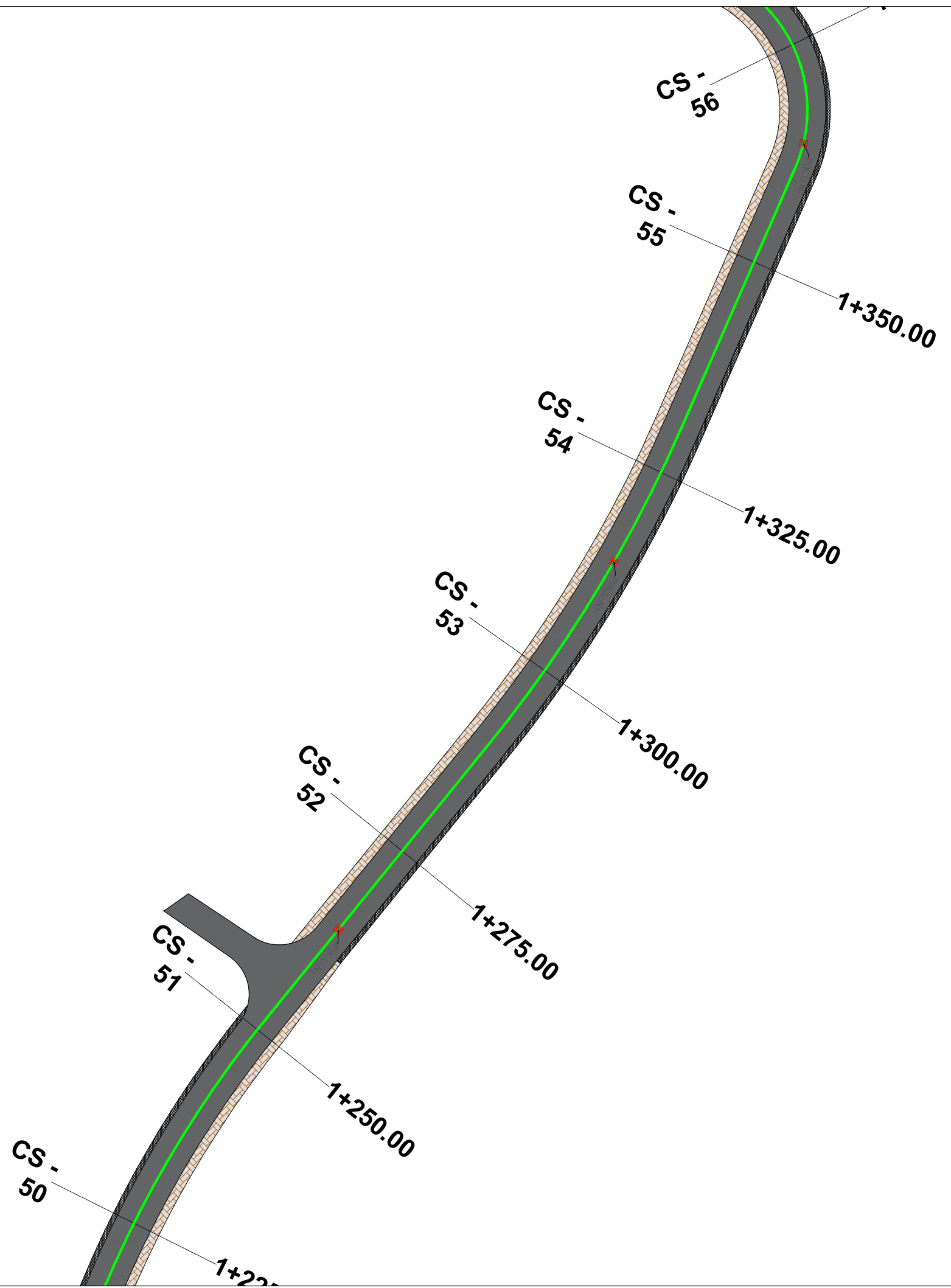

**LEGJENDA**

	SIPËRFAQE ME ASFALT
	KUNETË
	TROTUAR
	BANKINË
	MUR I RI
	KANAL I RI
	KANAL EKZISTUES
	GARDH I RI
	TUB I RI
	PUSËTË K.U.N
	LINIË K.U.N

**TITULLI I PROJEKTIT**

“REHABILITIMI I INFRASTRUKTURËS RRUGORE  
NË NJËSINË ADMINISTRATIVE  
VAQARR - PEZË - NDRIQ”

FAZA

PROJEKT ZBATIM

**RRUGA E FSHATIT MËNIK**

EMËRTIMI I FLETËS PLANIMETRIA K.U.N

SHKALLA **1:500**

NUMRI I FLETËS **T-226**

2024

AUTORITETI KONTRAKTOR:  
BASHKIA TIRANË



PROJEKTUESI: “NET-GROUP” SH.P.K



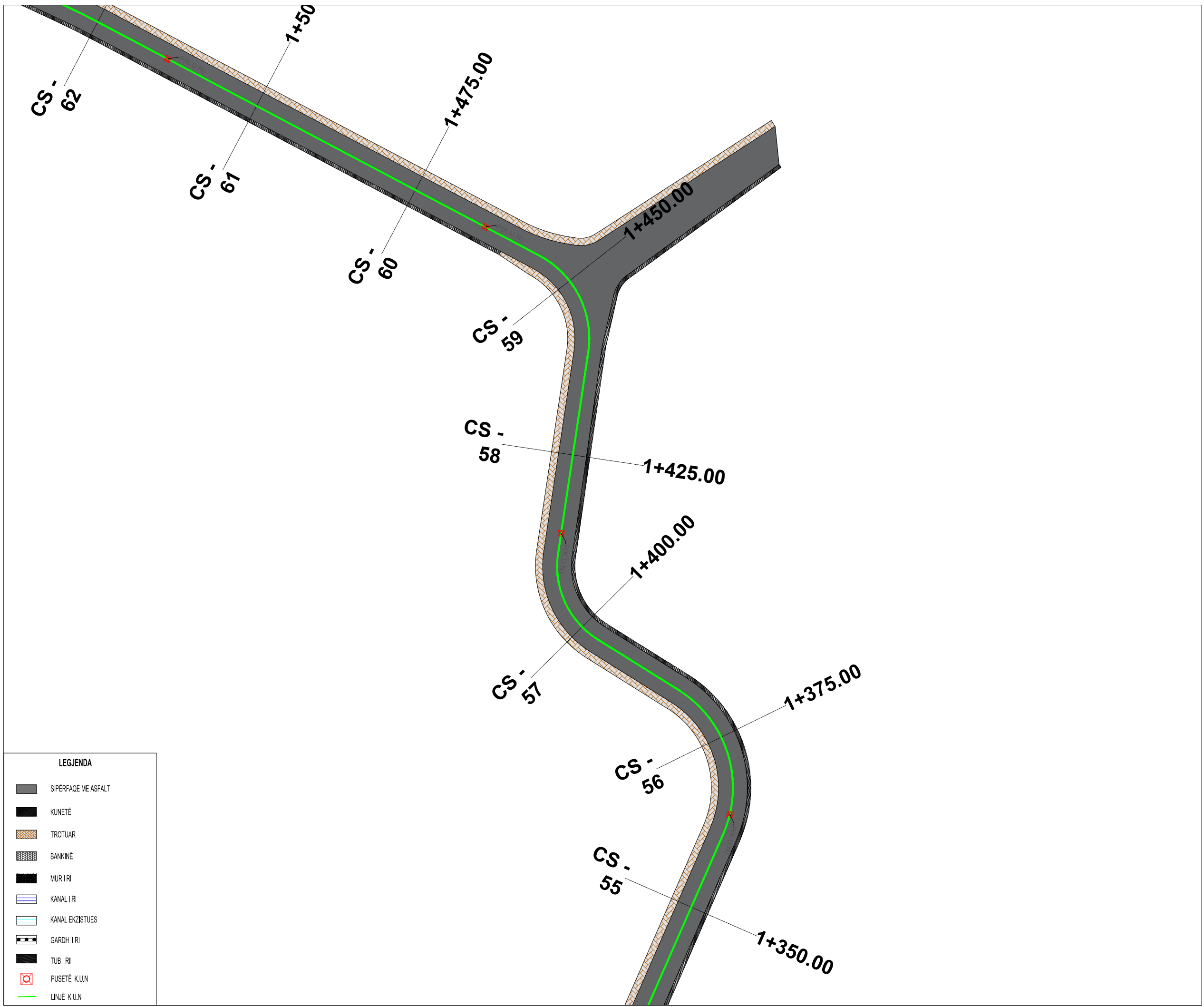

**LEGJENDA**

	SIPËRFAQE ME ASFALT
	KUNETË
	TROTUAR
	BANKINË
	MUR I RI
	KANAL I RI
	KANAL EKZISTUES
	GARDH I RI
	TUB I RI
	PUSETË K.U.N
	LINJË K.U.N

<b>TITULLI I PROJEKTIT</b>	
"REHABILITIMI I INFRASTRUKTURËS RRUGORE NË NJËSINË ADMINISTRATIVE VAQARR - PEZË - NDROQ"	
FAZA	
PROJEKT ZBATIM	
<b>RRUGA E FSHATIT MËNIK</b>	
EMËRTIMI I FLETËS PLANIMETRIA K.U.N	
SHKALLA	<b>1:500</b>
NUMRI I FLETËS	<b>T-227</b>
2024	

AUTORITETI KONTRAKTOR:  
BASHKIA TIRANË



PROJEKTUESI: "NET-GROUP" SH.P.K



TITULLI I PROJEKTIT

“REHABILITIMI I INFRASTRUKTURËS RRUGORE  
NË NJËSINË ADMINISTRATIVE  
VAQARR - PEZË - NDROQ”

FAZA

PROJEKT ZBATIM

RRUGA E FSHATIT MËNIK

EMËRTIMI I FLETËS PLANIMETRIA K.U.N

SHKALLA 1:500

NUMRI I FLETËS T-228

2024

AUTORITETI KONTRAKTOR:  
BASHKIA TIRANË



PROJEKTUESI: “NET-GROUP” SH.P.K

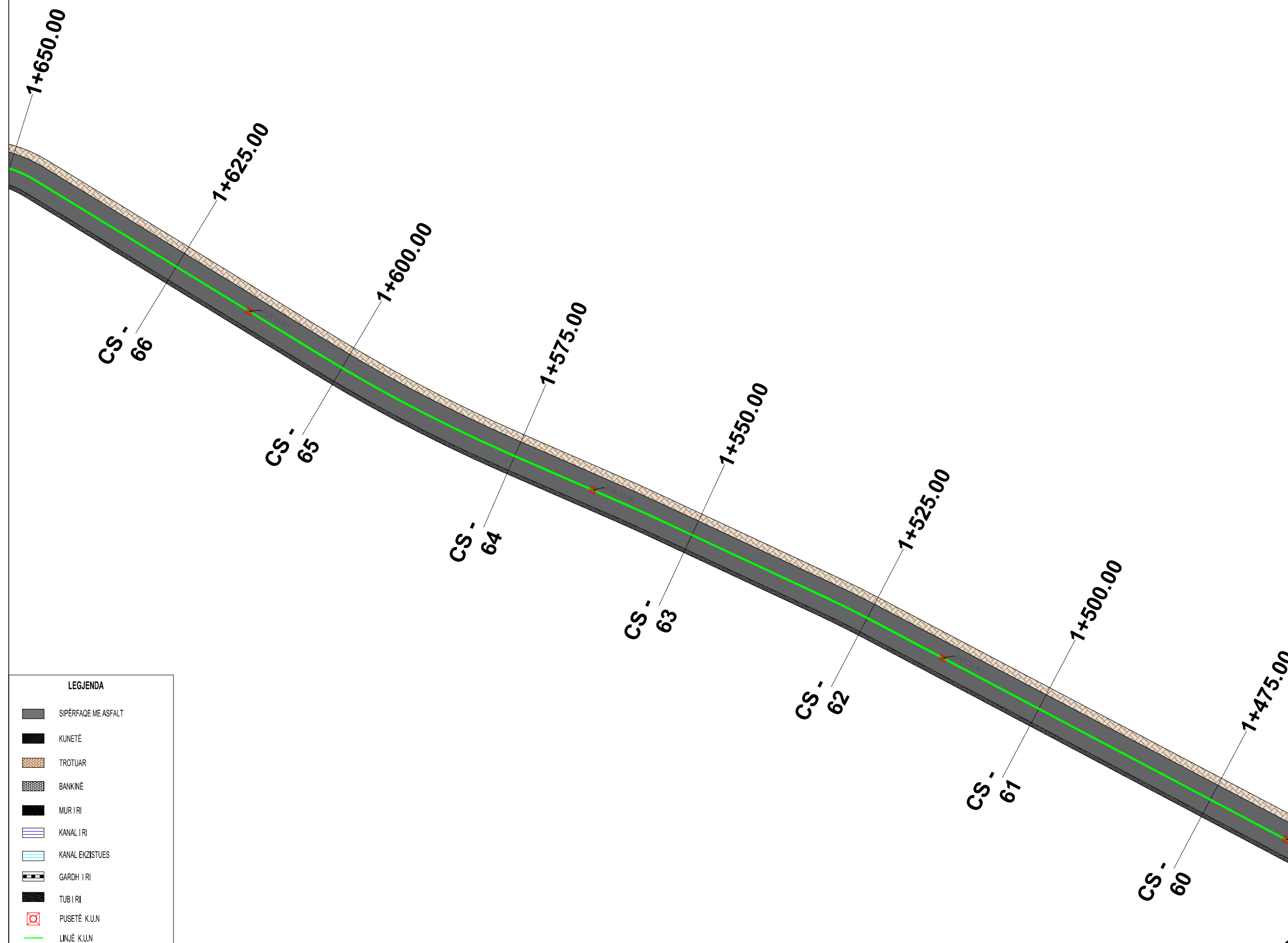

LEGJENDA

- SIPËRFAQE ME ASFALT
- KUNETË
- TROTUAR
- BANKINË
- MUR I RI
- KANAL I RI
- KANAL EKZISTUES
- GARDH I RI
- TUB I RI
- PUSETË K.U.N
- LINJË K.U.N

TITULLI I PROJEKTIT

“REHABILITIMI I INFRASTRUKTURËS RRUGORE  
NË NJËSINË ADMINISTRATIVE  
VAQARR - PEZË - NDROQ”

FAZA

PROJEKT ZBATIM

RRUGA E FSHATIT MËNIK

EMËRTIMI I FLETËS PLANIMETRIA K.U.N

SHKALLA 1:500

NUMRI I FLETËS T-229

2024

AUTORITETI KONTRAKTOR:  
BASHKIA TIRANË



PROJEKTUESI: “NET-GROUP” SH.P.K

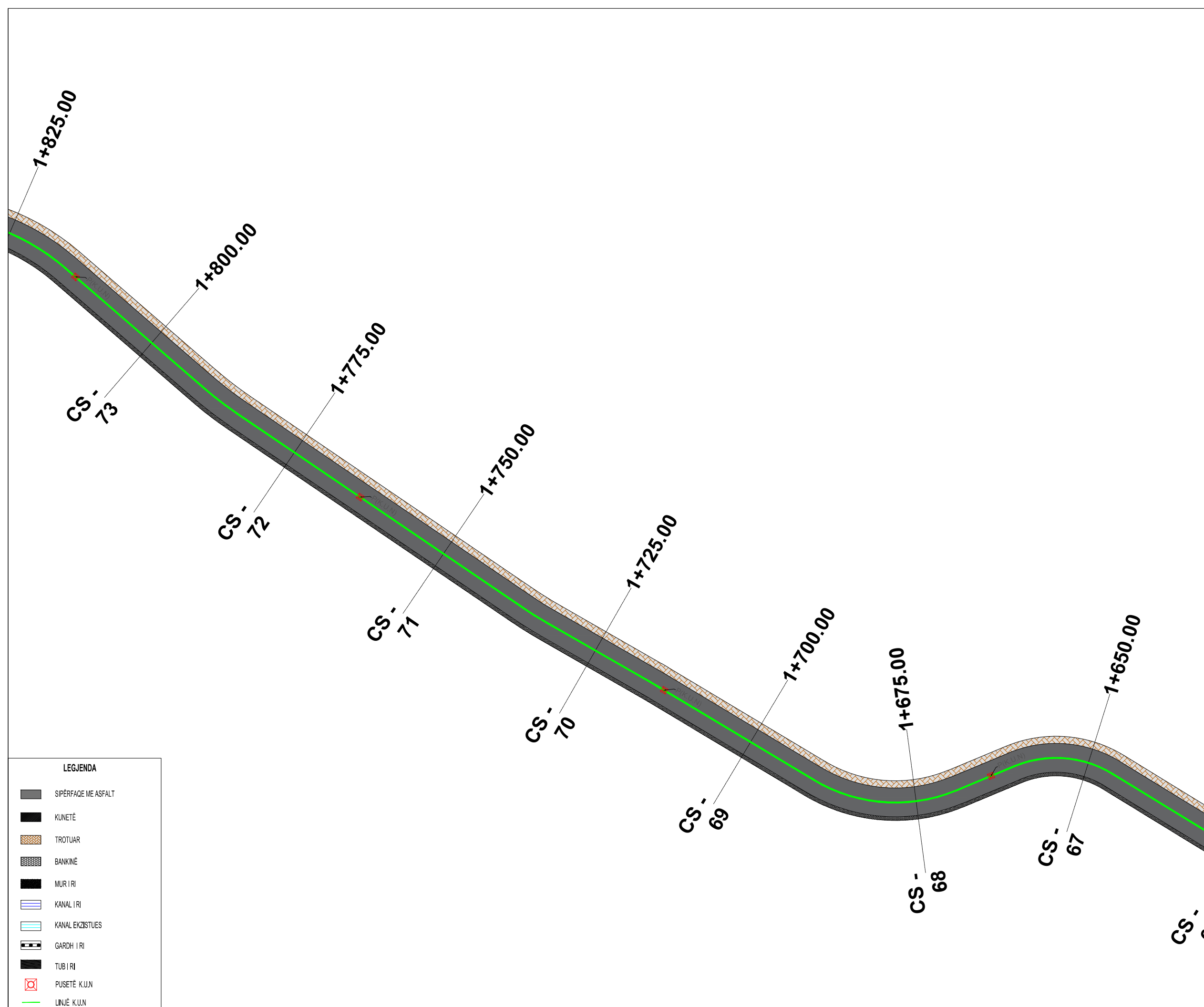

LEGJENDA

- SIPËRFAQE ME ASFALT
- KUNETË
- TROTUAR
- BANKINË
- MUR I RI
- KANAL I RI
- KANAL EKZISTUES
- GARDH I RI
- TUB I RI
- PUSETË K.U.N
- LINJË K.U.N



TITULLI I PROJEKTIT

“REHABILITIMI I INFRASTRUKTURËS RRUGORE  
NË NJËSINË ADMINISTRATIVE  
VAQARR - PEZË - NDROQ”

FAZA

PROJEKT ZBATIM

RRUGA E FSHATIT MËNIK

EMËRTIMI I FLETËS PLANIMETRIA K.U.N

SHKALLA 1:500

NUMRI I FLETËS T-230

2024

AUTORITETI KONTRAKTOR:  
BASHKIA TIRANË



PROJEKTUESI: “NET-GROUP” SH.P.K

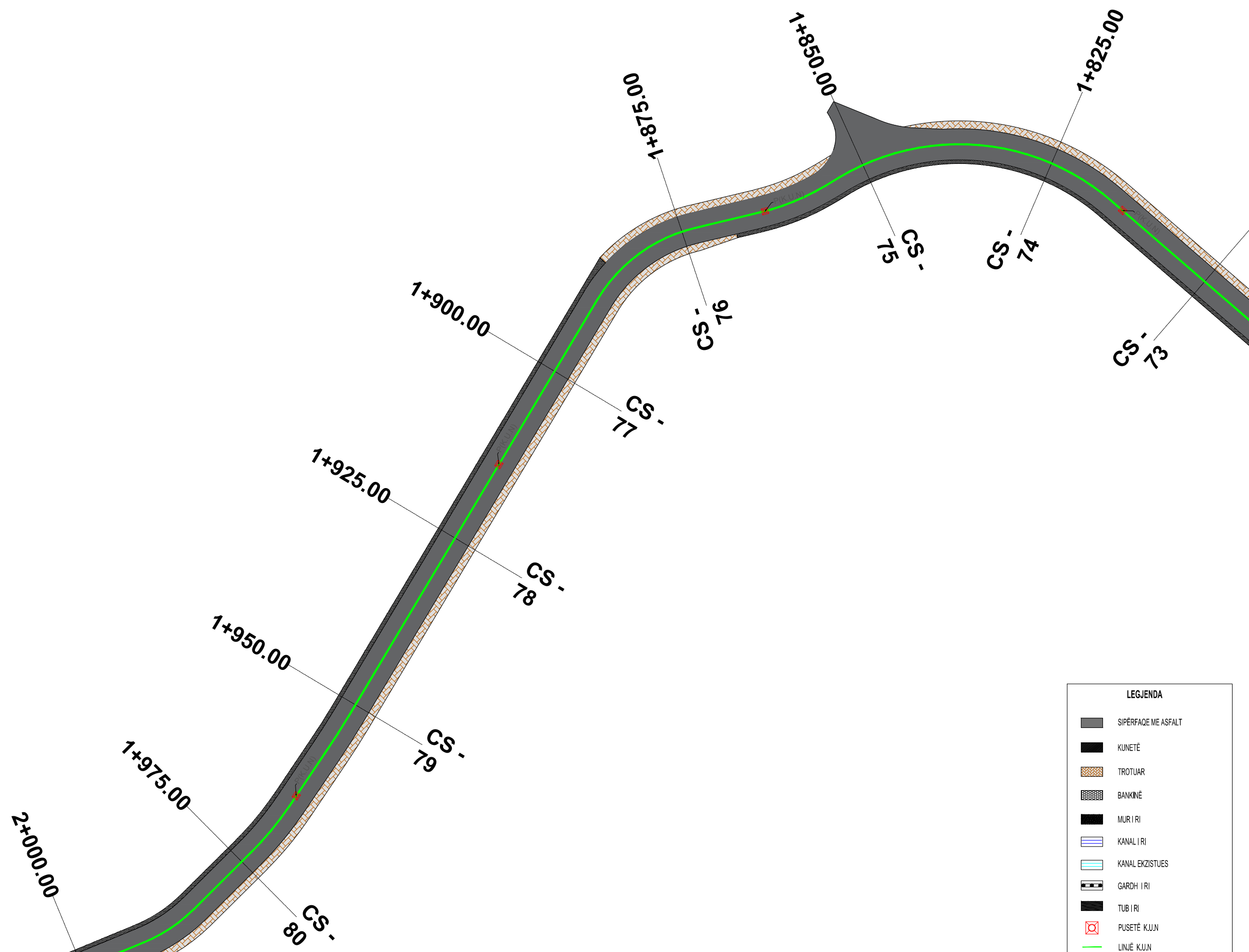

LEGJENDA	
	SIPERFAQE ME ASFALT
	KUNETË
	TROTUAR
	BANKINË
	MUR I RI
	KANAL I RI
	KANAL EKZISTUES
	GARDH I RI
	TUB I RI
	PUSETË KUJ.N
	LINJË KUJ.N

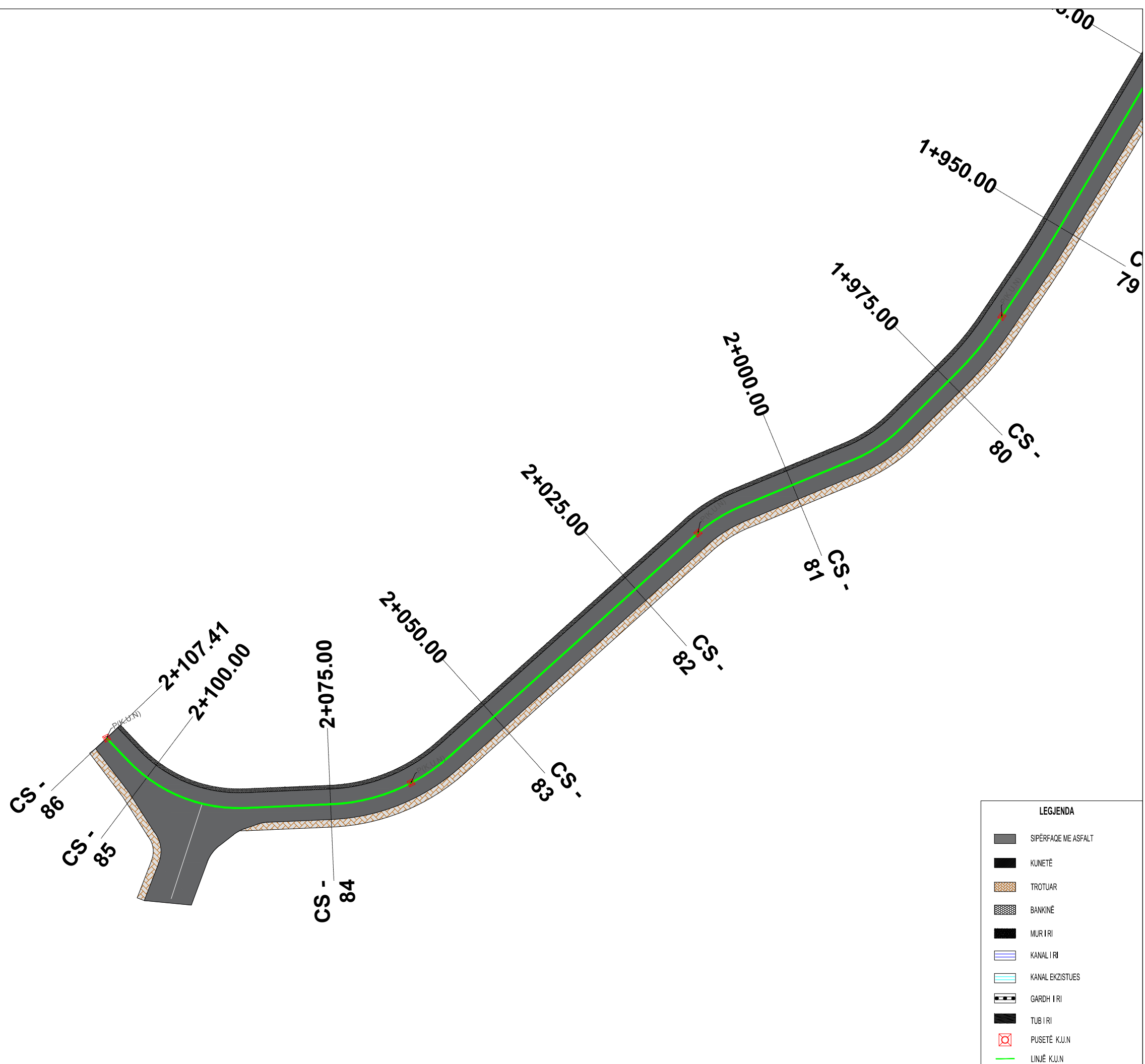

**TITULLI I PROJEKTIT**

“REHABILITIMI I INFRASTRUKTURËS RRUGORE  
NË NJËSINË ADMINISTRATIVE  
VAQARR - PEZË - NDRUQ”

FAZA

PROJEKT ZBATIM

**RRUGA E FSHATIT MËNIK**

EMËRTIMI I FLETËS PLANIMETRIA K.U.N

SHKALLA **1:500**

NUMRI I FLETËS **T-231**

2024

**LEGJENDA**

-  SIPËRFAQE ME ASFALT
-  KUNETË
-  TROTUAR
-  BANKINË
-  MUR I RI
-  KANAL I RI
-  KANAL EKZISTUES
-  GARDH I RI
-  TUB I RI
-  PUSËTË K.U.N
-  LINJË K.U.N

AUTORITETI KONTRAKTOR:  
BASHKIA TIRANË



PROJEKTUESI: “NET-GROUP” SH.P.K



**TITULLI I PROJEKTIT**

“REHABILITIMI I INFRASTRUKTURËS RRUGORE  
NË NJËSINË ADMINISTRATIVE  
VAQARR - PEZË - NDRUQ”

FAZA

**PROJEKT ZBATIM**

**RRUGA TE URA E  
TABAKES-PEZE HELMES**

EMËRTIMI I FLETËS PLANIMETRIA K.U.N

SHKALLA **1:3000**

NUMRI I FLETËS **T-232**

2024

AUTORITETI KONTRAKTOR:  
BASHKIA TIRANË



PROJEKTUESI: “NET-GROUP” SH.P.K

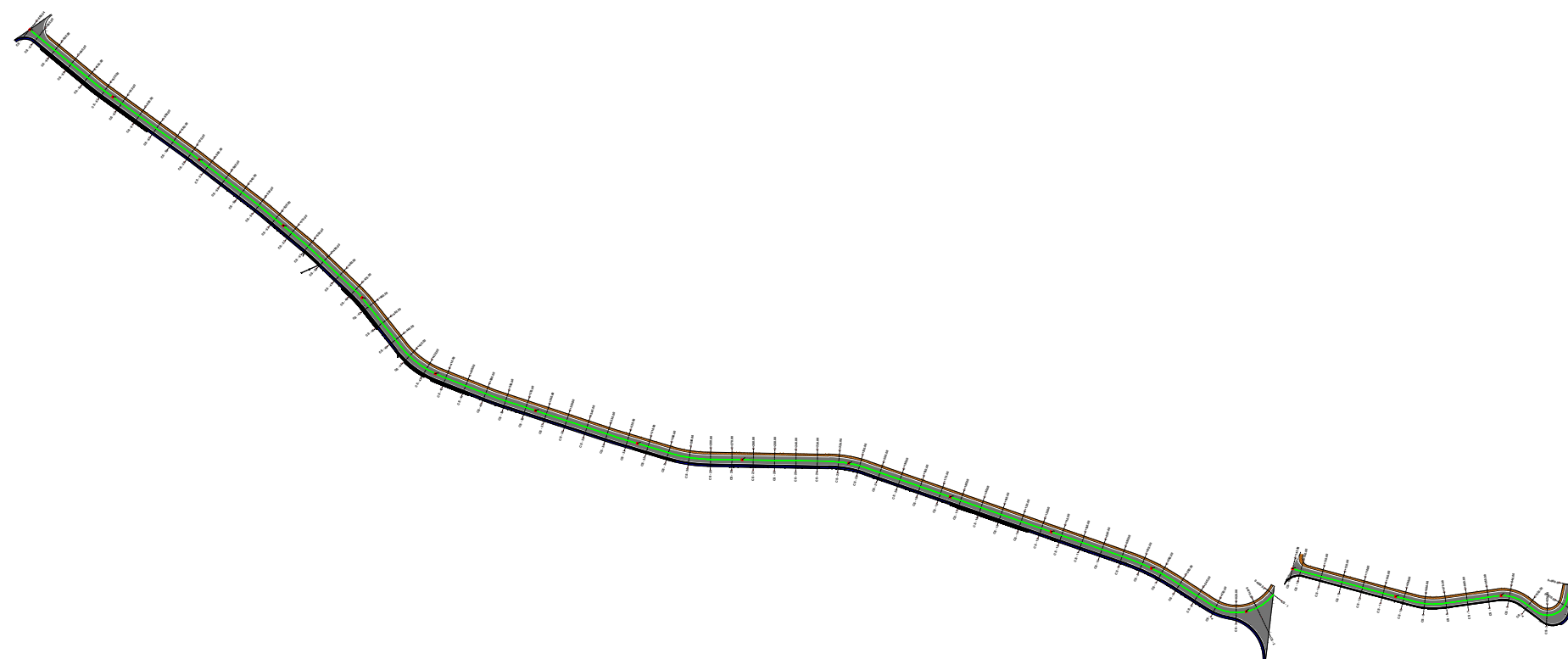

**LEGJENDA**

-  SIPËRFAQE ME ASFALT
-  KUNETË
-  TROTUAR
-  BANKINË
-  MUR I RI
-  KANAL I RI
-  KANAL EKZISTUES
-  GARDH I RI
-  TUB I RI
-  PUSËTË K.U.N
-  LINJË K.U.N

# TITULLI I PROJEKTIT

“REHABILITIMI I INFRASTRUKTURËS RRUGORE  
NË NJËSINË ADMINISTRATIVE  
VAQARR - PEZË - NDRIQ”

FAZA

PROJEKT ZBATIM

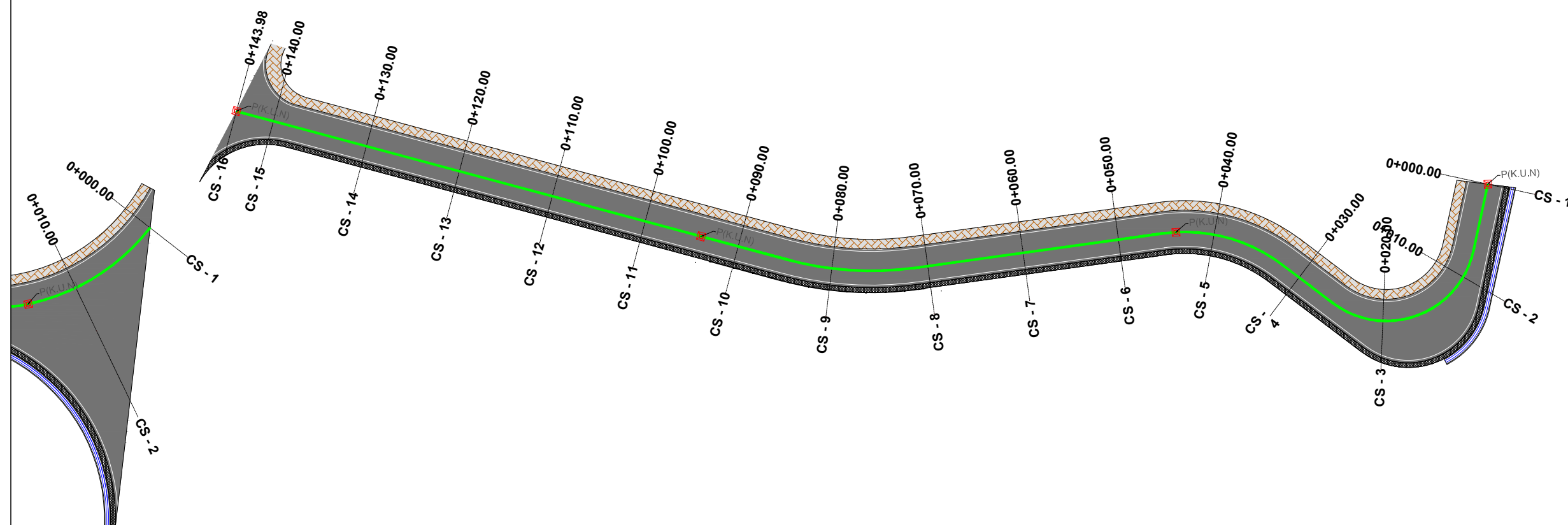

## LEGJENDA

- SIPËRFAQE ME ASFALT
- KUNETË
- TROTUAR
- BANKINË
- MUR I RI
- KANAL I RI
- KANAL EKZISTUES
- GARDH I RI
- TUB I RI
- PUSËTË K.U.N
- LINJË K.U.N

## RRUGA TE URA E TABAKES-PEZE HELMES

EMËRTIMI I FLETËS PLANIMETRIA K.U.N

SHKALLA **1:500**

NUMRI I FLETËS **T-233**

2024

AUTORITETI KONTRAKTOR:  
BASHKIA TIRANË



PROJEKTUESI: "NET-GROUP" SH.P.K



# TITULLI I PROJEKTIT

“REHABILITIMI I INFRASTRUKTURËS RRUGORE  
NË NJËSINË ADMINISTRATIVE  
VAQARR - PEZË - NDRUQ”

FAZA

PROJEKT ZBATIM

## RRUGA TE URA E TABAKES-PEZE HELMES

EMËRTIMI I FLETËS PLANIMETRIA K.U.N

SHKALLA **1:500**

NUMRI I FLETËS **T-234**

2024

AUTORITETI KONTRAKTOR:  
BASHKIA TIRANË



PROJEKTUESI: “NET-GROUP” SH.P.K

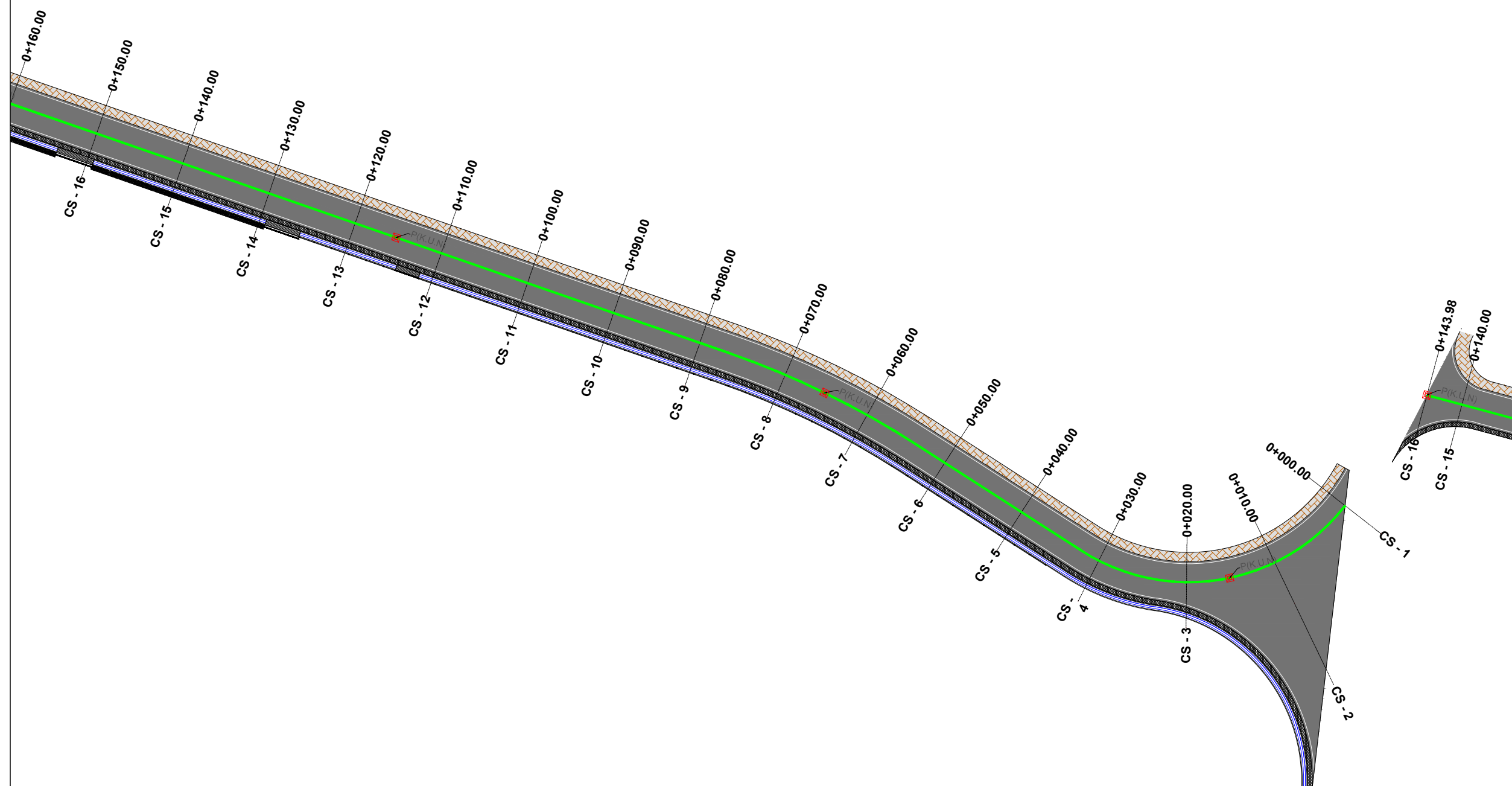

### LEGJENDA

- SIPËRFAQE ME ASFALT
- KUNETË
- TROTUAR
- BANKINË
- MUR I RI
- KANAL I RI
- KANAL EKZISTUES
- GARDH I RI
- TUB I RI
- PUSËTË K.U.N
- LINJË K.U.N

# TITULLI I PROJEKTIT

“REHABILITIMI I INFRASTRUKTURËS RRUGORE  
NË NJËSINË ADMINISTRATIVE  
VAQARR - PEZË - NDROQ”

FAZA

PROJEKT ZBATIM

## RRUGA TE URA E TABAKES-PEZE HELMES

EMËRTIMI I FLETËS PLANIMETRIA K.U.N

SHKALLA **1:500**

NUMRI I FLETËS **T-235**

2024

AUTORITETI KONTRAKTOR:  
BASHKIA TIRANË



PROJEKTUESI: “NET-GROUP” SH.P.K

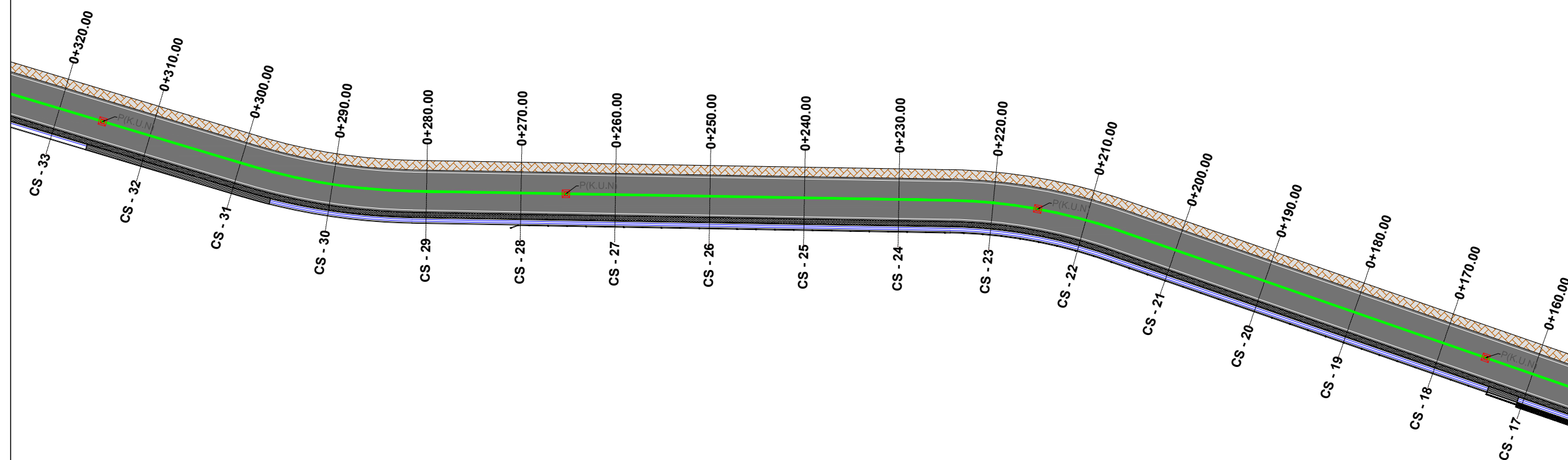

### LEGJENDA

- SIPËRFAQE ME ASFALT
- KUNETË
- TROTUAR
- BANKINË
- MUR I RI
- KANAL I RI
- KANAL EKZISTUES
- GARDH I RI
- TUB I RI
- PUSETË K.U.N
- LINJË K.U.N

TITULLI I PROJEKTIT

“REHABILITIMI I INFRASTRUKTURËS RRUGORE  
NË NJËSINË ADMINISTRATIVE  
VAQARR - PEZË - NDRUQ”

FAZA

PROJEKT ZBATIM

RRUGA TE URA E  
TABAKES-PEZE HELMES

EMËRTIMI I FLETËS PLANIMETRIA K.U.N

SHKALLA 1:500

NUMRI I FLETËS T-236

2024

AUTORITETI KONTRAKTOR:  
BASHKIA TIRANË



PROJEKTUESI: "NET-GROUP" SH.P.K

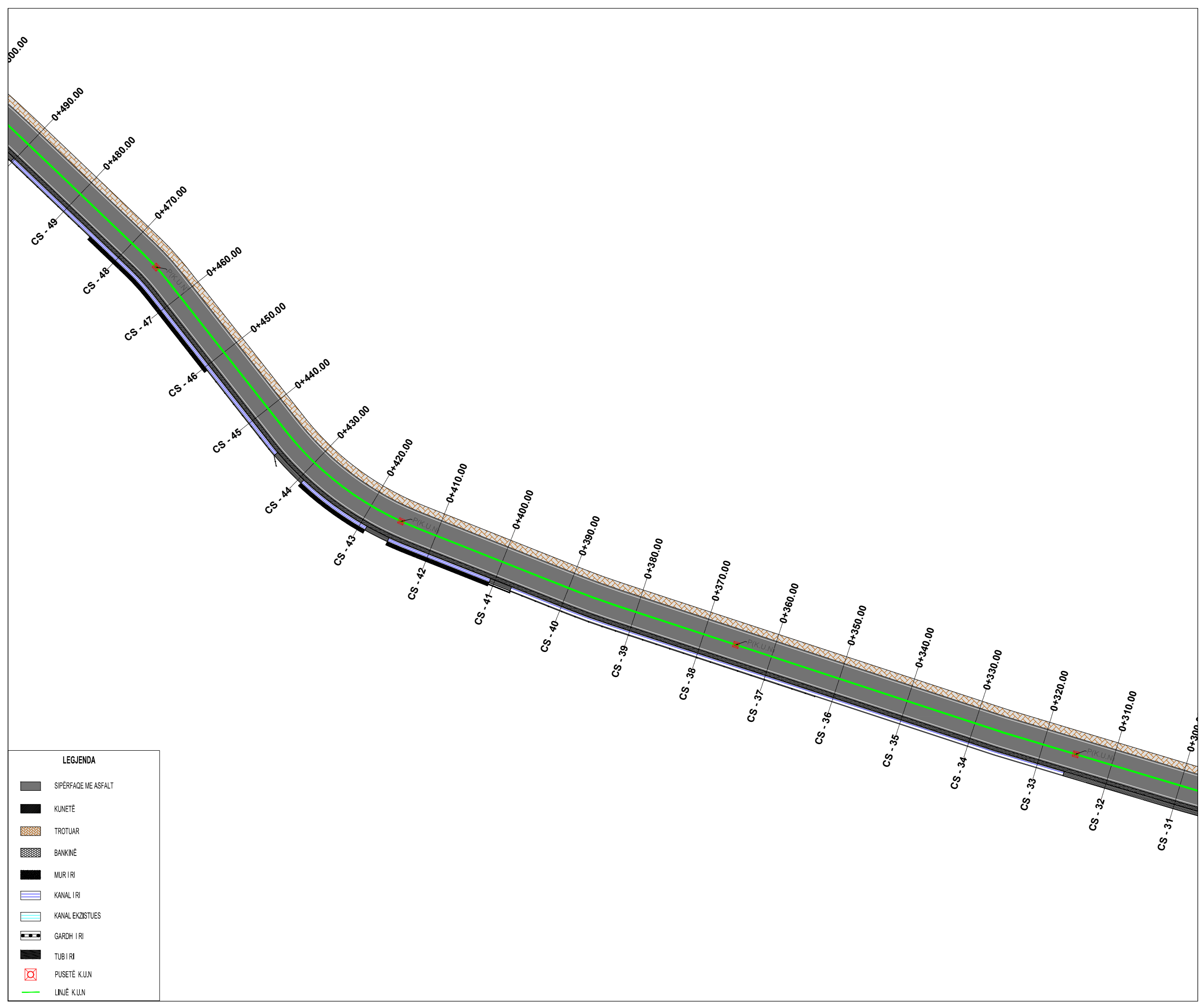

LEGJENDA

- SIPËRFAQE ME ASFALT
- KUNETË
- TROTUAR
- BANKINË
- MUR I RI
- KANAL I RI
- KANAL EKZISTUES
- GARDH I RI
- TUB I RI
- PUSETË K.U.N
- LINJË K.U.N

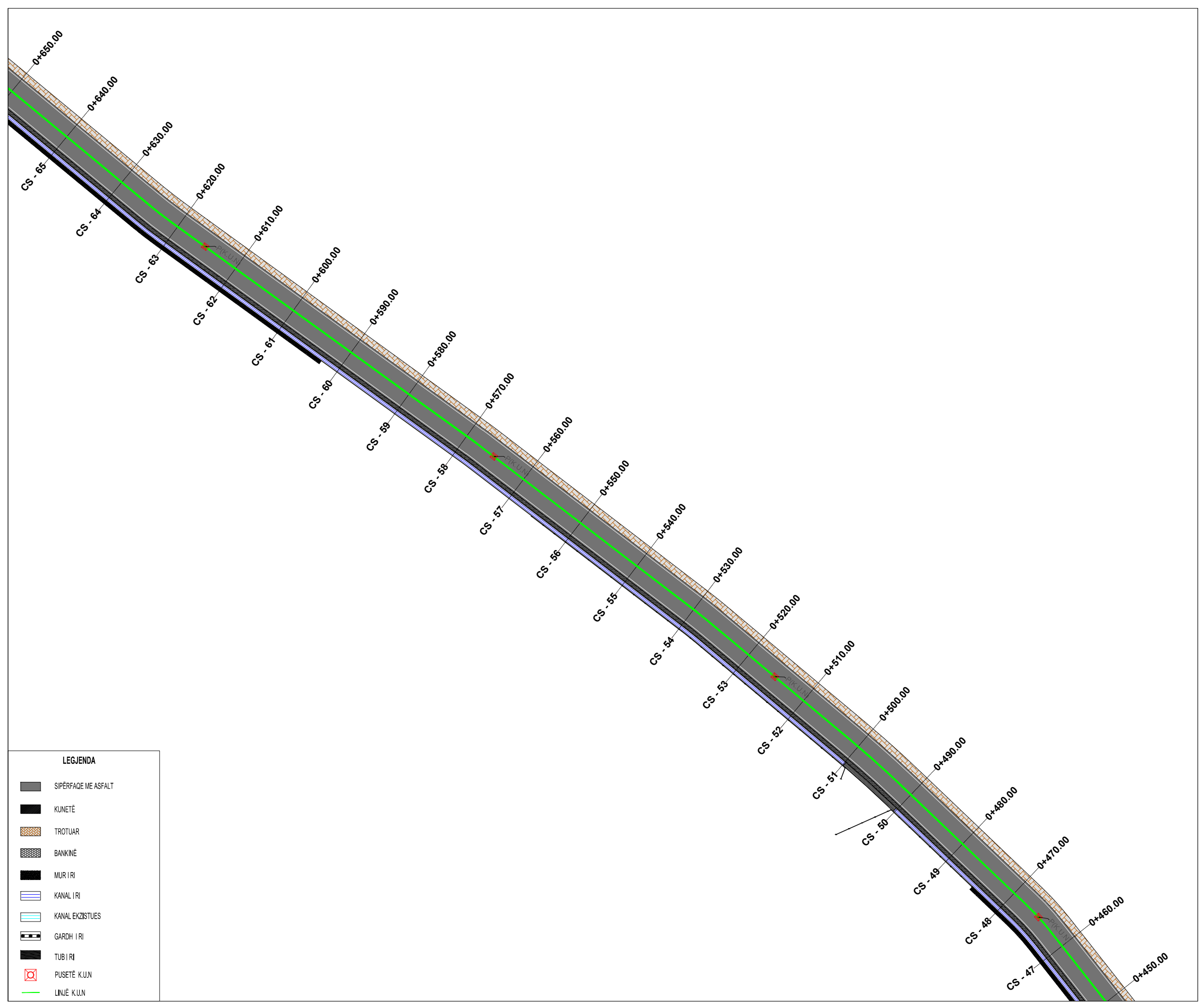

**LEGJENDA**

	SIPERFAQE ME ASFALT
	KUNETË
	TROTUAR
	BANKINË
	MUR I RI
	KANAL I RI
	KANAL EKZISTUES
	GARDH I RI
	TUB I RI
	PUSETË K.U.N
	LINJË K.U.N

**TITULLI I PROJEKTIT**

“REHABILITIMI I INFRASTRUKTURËS RRUGORE  
NË NJËSINË ADMINISTRATIVE  
VAQARR - PEZË - NDROQ”

FAZA

PROJEKT ZBATIM

**RRUGA TE URA E  
TABAKES-PEZE HELMES**

EMËRTIMI I FLETËS PLANIMETRIA K.U.N

SHKALLA **1:500**

NUMRI I FLETËS **T-237**

2024

AUTORITETI KONTRAKTOR:  
BASHKIA TIRANË



PROJEKTUESI: “NET-GROUP” SH.P.K





# TITULLI I PROJEKTIT

“REHABILITIMI I INFRASTRUKTURËS RRUGORE  
NË NJËSINË ADMINISTRATIVE  
VAQARR - PEZË - NDROQ”

FAZA

PROJEKT ZBATIM

## RRUGA TE URA E TABAKES-PEZE HELMES

EMËRTIMI I FLETËS PLANIMETRIA K.U.N

SHKALLA **1:500**

NUMRI I FLETËS **T-238**

2024

AUTORITETI KONTRAKTOR:  
BASHKIA TIRANË



PROJEKTUESI: "NET-GROUP" SH.P.K

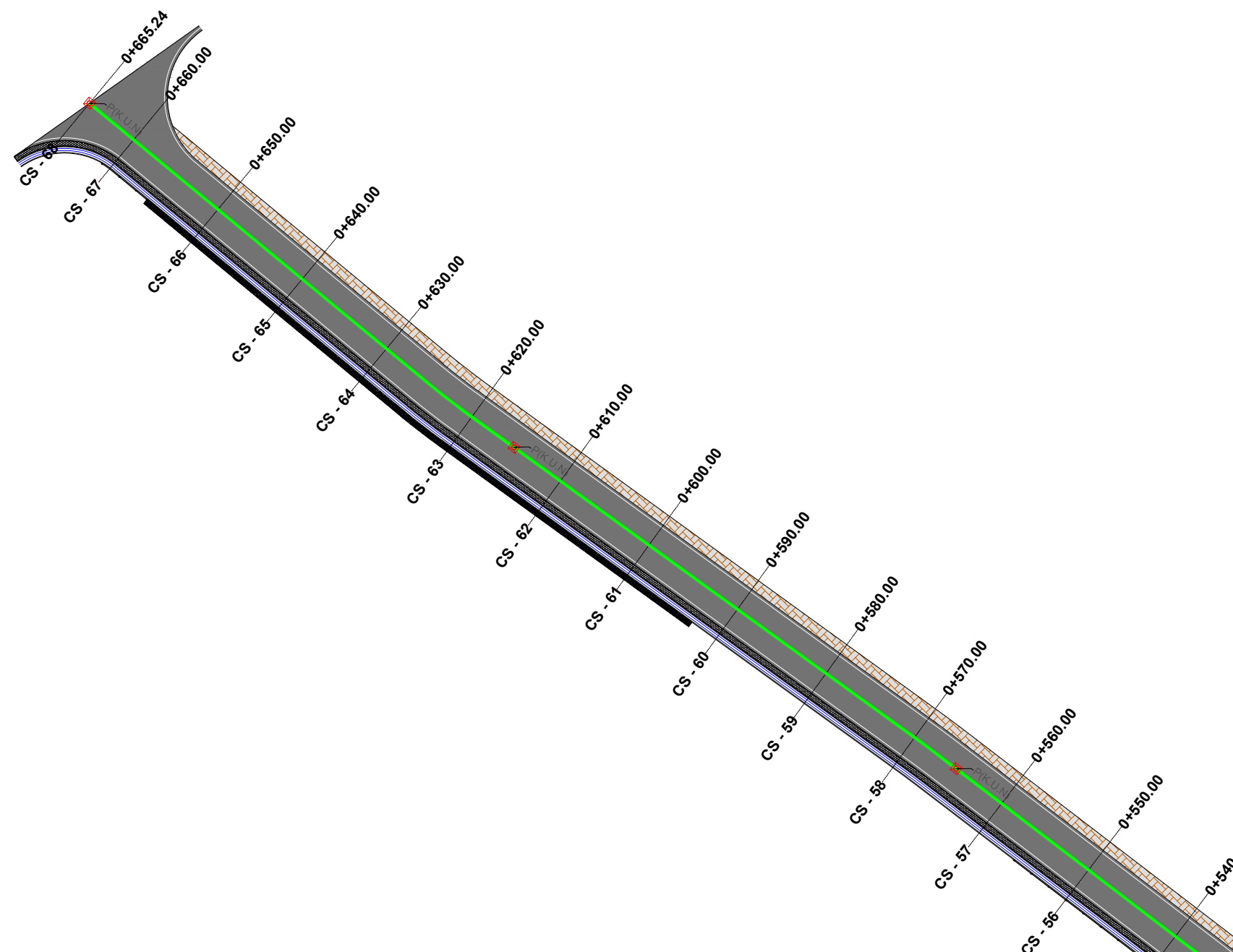

### LEGJENDA

- SIPËRFAQE ME ASFALT
- KUNETË
- TROTUAR
- BANKINË
- MUR I RI
- KANAL I RI
- KANAL EKZISTUES
- GARDH I RI
- TUB I RI
- PUSETË K.U.N
- LINJË K.U.N

# TITULLI I PROJEKTIT

“REHABILITIMI I INFRASTRUKTURËS RRUGORE  
NË NJËSINË ADMINISTRATIVE  
VAQARR - PEZË - NDRIQ”

FAZA

PROJEKT ZBATIM

RRUGA TE BREGU ERZENIT-  
PEZE

EMËRTIMI I FLETËS PLANIMETRIA K.U.N

SHKALLA **1:2500**

NUMRI I FLETËS **T-239**

2024

AUTORITETI KONTRAKTOR:  
BASHKIA TIRANË



PROJEKTUESI: “NET-GROUP” SH.P.K

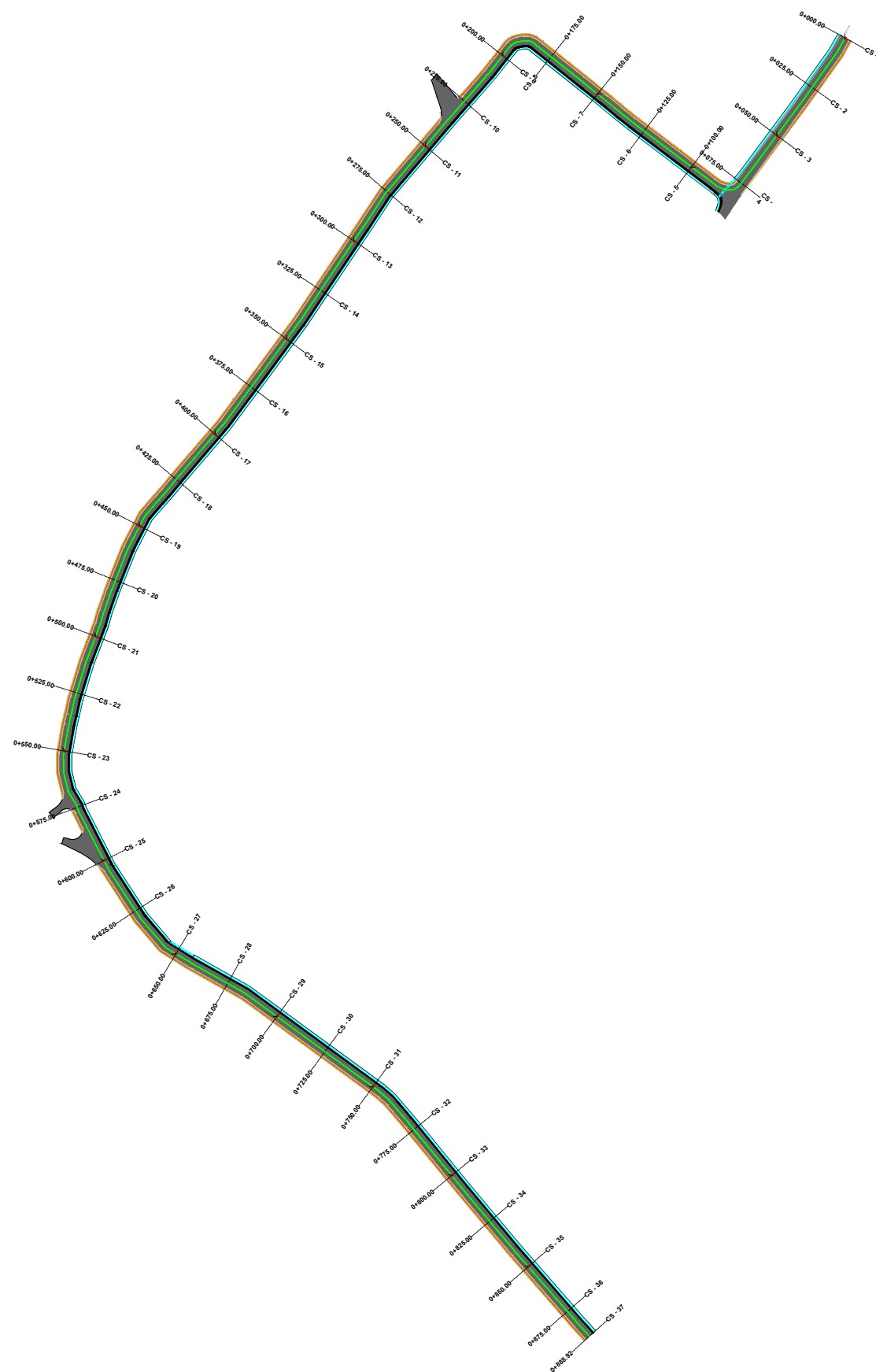

## LEGJENDA

- SIPËRFAQE ME ASFALT
- KUNETË
- TROTUAR
- BANKINË
- MUR I RI
- KANAL I RI
- KANAL EKZISTUES
- GARDH I RI
- TUB I RI
- PUSËTË K.U.N
- LINJË K.U.N

TITULLI I PROJEKTIT

“REHABILITIMI I INFRASTRUKTURËS RRUGORE  
NË NJËSINË ADMINISTRATIVE  
VAQARR - PEZË - NDRROQ”

FAZA

PROJEKT ZBATIM

RRUGA TE BREGU ERZENIT-  
PEZE

EMËRTIMI I FLETËS PLANIMETRIA K.U.N

SHKALLA 1:500

NUMRI I FLETËS T-240

2024

AUTORITETI KONTRAKTOR:  
BASHKIA TIRANË



PROJEKTUESI: “NET-GROUP” SH.P.K

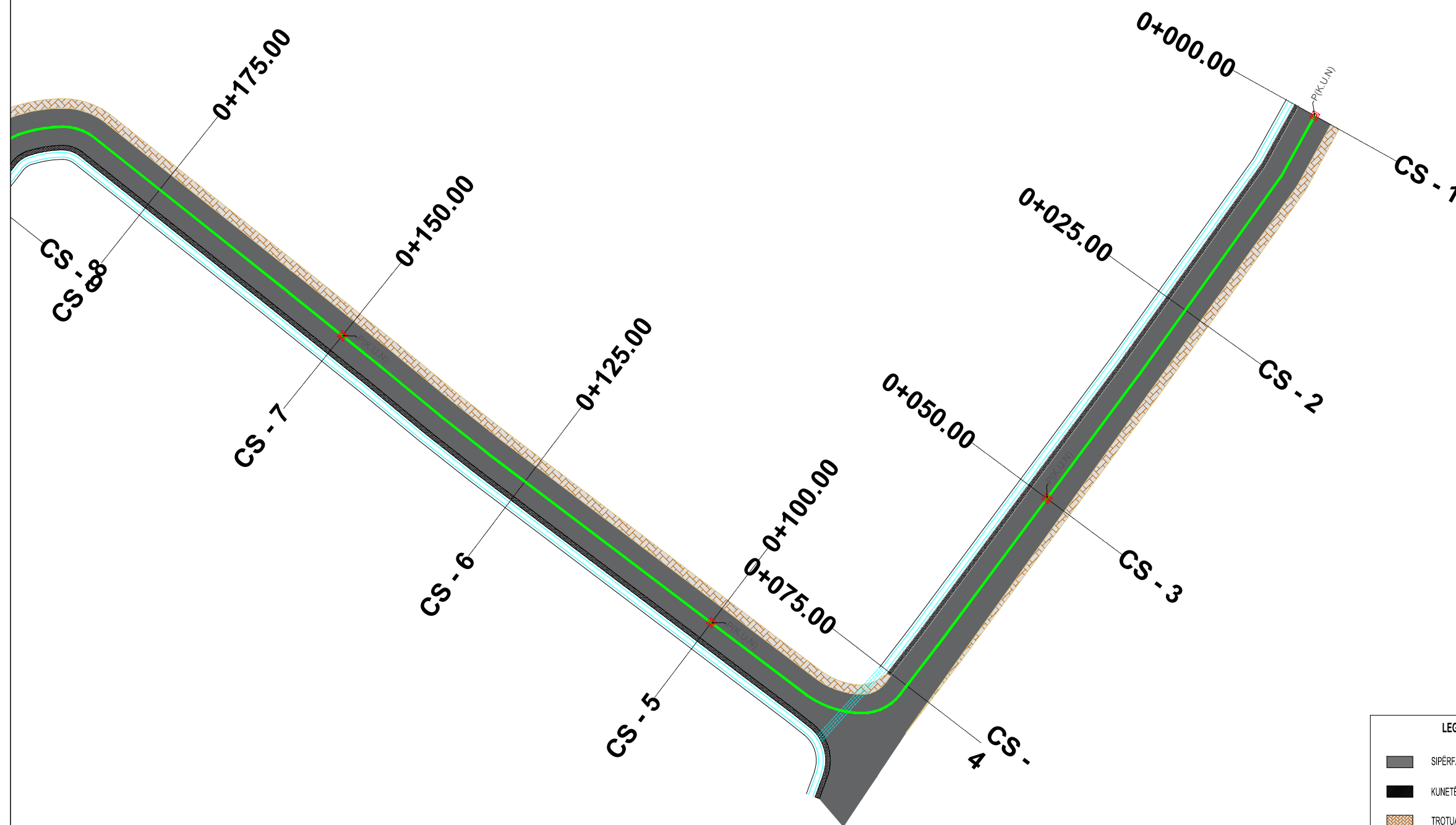

LEGJENDA

- SIPËRFAQE ME ASFALT
- KUNETË
- TROTUAR
- BANKINË
- MUR I RI
- KANAL I RI
- KANAL EKZISTUES
- GARDH I RI
- TUB I RI
- PUSETË K.U.N
- LINIË K.U.N

TITULLI I PROJEKTIT

“REHABILITIMI I INFRASTRUKTURËS RRUGORE  
NË NJËSINË ADMINISTRATIVE  
VAQARR - PEZË - NDROQ”

FAZA

PROJEKT ZBATIM

RRUGA TE BREGU ERZENIT-  
PEZE

EMËRTIMI I FLETËS PLANIMETRIA K.U.N

SHKALLA 1:500

NUMRI I FLETËS T-241

2024

AUTORITETI KONTRAKTOR:  
BASHKIA TIRANË



PROJEKTUESI: “NET-GROUP” SH.P.K

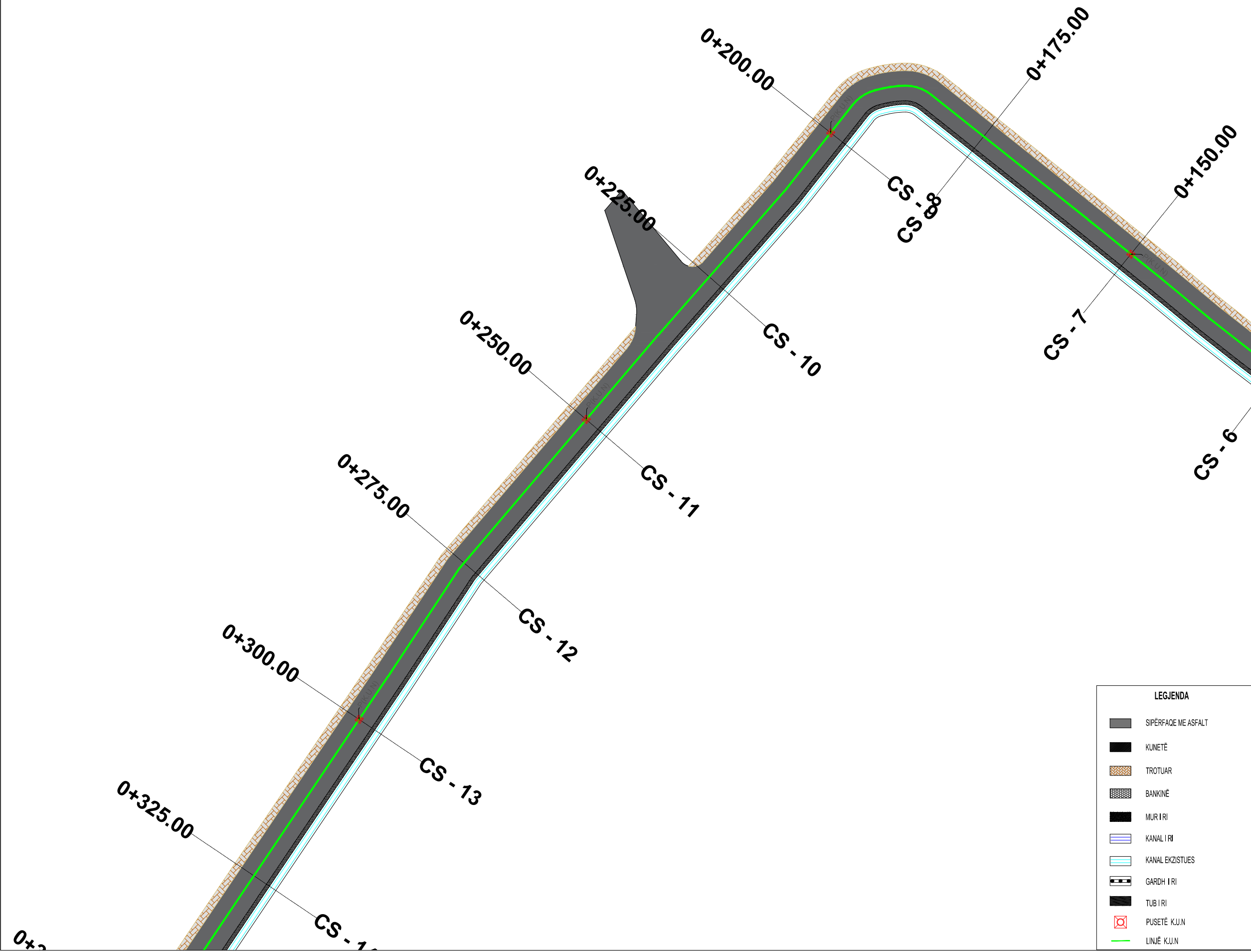

LEGJENDA

- SIPËRFAQE ME ASFALT
- KUNETË
- TROTUAR
- BANKINË
- MUR I RI
- KANAL I RI
- KANAL EKZISTUES
- GARDH I RI
- TUB I RI
- PUSETË K.U.N
- LINJË K.U.N

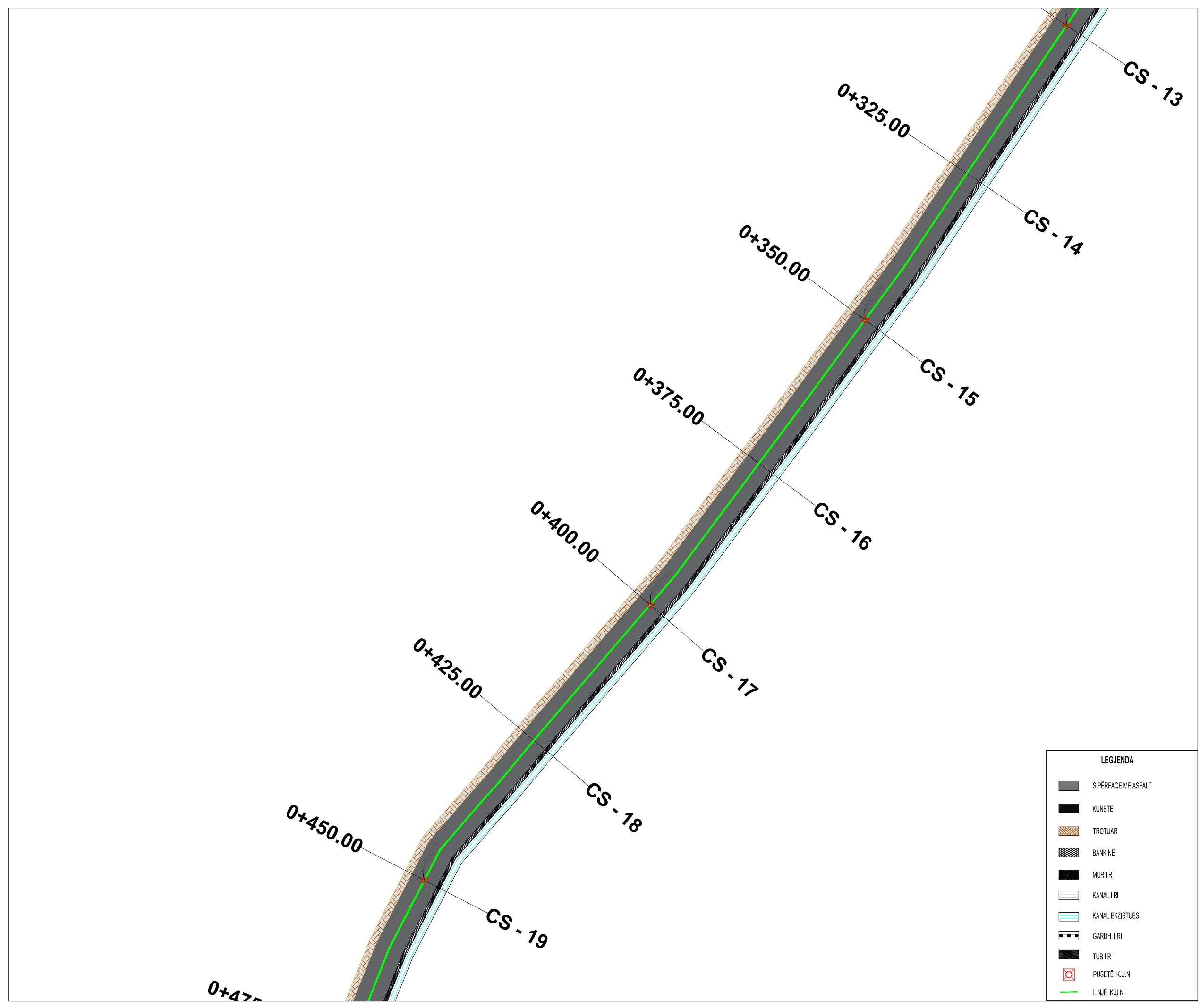

**LEGJENDA**

	SIPËRFAQE ME ASFALT
	KUNETË
	TROTUAR
	BANKINË
	MUR I RI
	KANAL I RI
	KANAL EKZISTUES
	GARDH I RI
	TUB I RI
	PUSETË K.U.N
	LINIË K.U.N

**TITULLI I PROJEKTIT**

“REHABILITIMI I INFRASTRUKTURËS RRUGORE NË NJËSINË ADMINISTRATIVE VAQARR - PEZË - NDROQ”

---

FAZA

**PROJEKT ZBATIM**

---

**RRUGA TE BREGU ERZENIT-PEZE**

---

EMËRTIMI I FLETËS PLANIMETRIA K.U.N

SHKALLA **1:500**

NUMRI I FLETËS **T-242**

2024

AUTORITETI KONTRAKTOR:

BASHKIA TIRANË



BASHKIA TIRANË

---

PROJEKTUESI: “NET-GROUP” SH.P.K



NET-GROUP

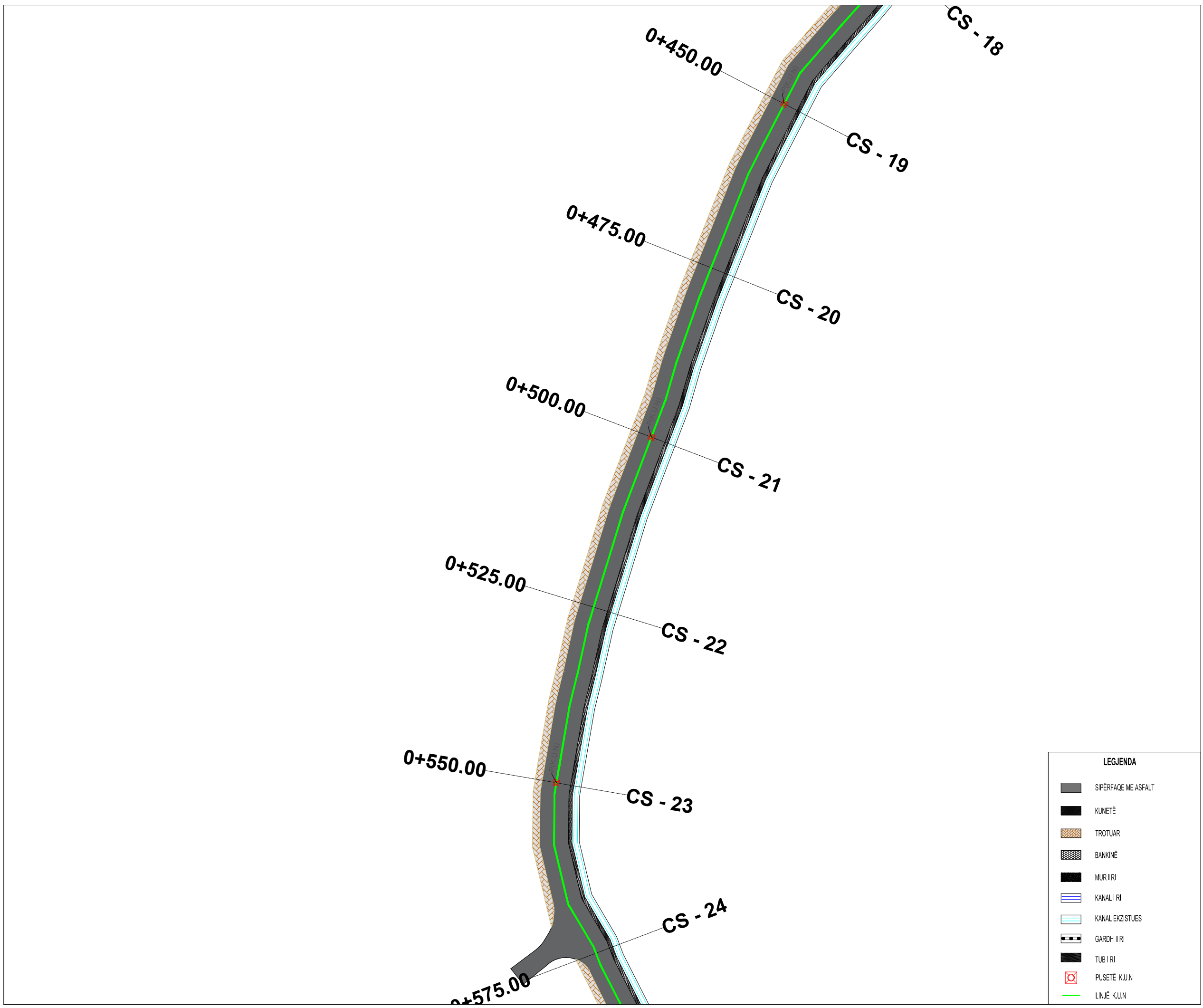

**TITULLI I PROJEKTIT**

“REHABILITIMI I INFRASTRUKTURËS RRUGORE  
NË NJËSINË ADMINISTRATIVE  
VAQARR - PEZË - NDRUQ”

FAZA

PROJEKT ZBATIM

**RRUGA TE BREGU ERZENIT-  
PEZE**

EMËRTIMI I FLETËS PLANIMETRIA K.U.N

SHKALLA **1:500**

NUMRI I FLETËS **T-243**

2024

AUTORITETI KONTRAKTOR:  
BASHKIA TIRANË



PROJEKTUESI: “NET-GROUP” SH.P.K





**TITULLI I PROJEKTIT**

“REHABILITIMI I INFRASTRUKTURËS RRUGORE  
NË NJËSINË ADMINISTRATIVE  
VAQARR - PEZË - NDRROQ”

FAZA

PROJEKT ZBATIM

**RRUGA TE BREGU ERZENIT-  
PEZE**

EMËRTIMI I FLETËS PLANIMETRIA K.U.N

SHKALLA **1:500**

NUMRI I FLETËS **T-244**

2024

AUTORITETI KONTRAKTOR:  
BASHKIA TIRANË



PROJEKTUESI: “NET-GROUP” SH.P.K



- LEGJENDA**
- SIPËRFAQE ME ASFALT
  - KUNETË
  - TROTUAR
  - BANKINË
  - MUR I RI
  - KANAL I RI
  - KANAL EKZISTUES
  - GARDH I RI
  - TUB I RI
  - PUSËTË K.U.N
  - LINJË K.U.N

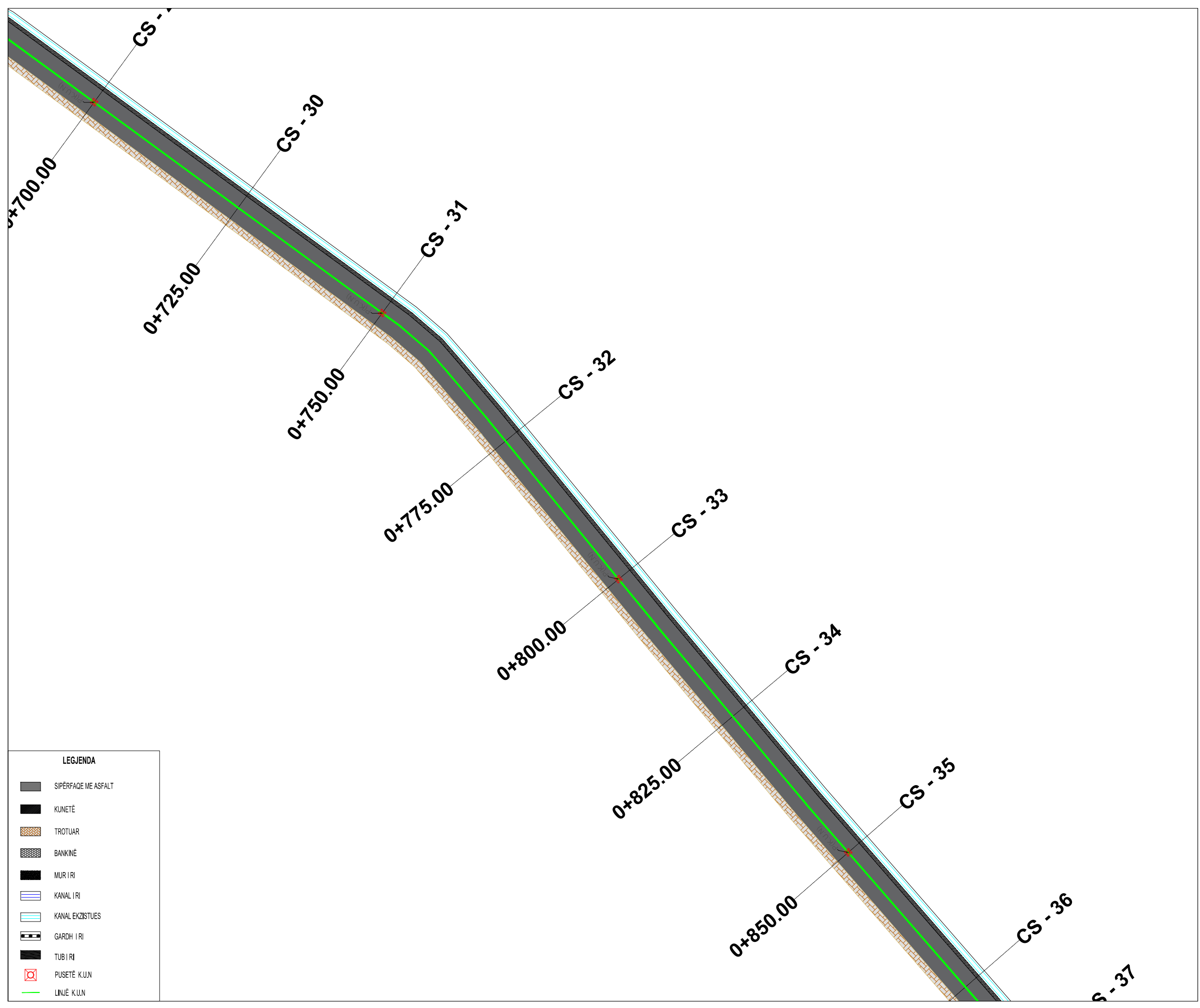

**TITULLI I PROJEKTIT**

“REHABILITIMI I INFRASTRUKTURËS RRUGORE  
NË NJËSINË ADMINISTRATIVE  
VAQARR - PEZË - NDROQ”

FAZA

PROJEKT ZBATIM

**RRUGA TE BREGU ERZENIT-  
PEZE**

EMËRTIMI I FLETËS PLANIMETRIA K.U.N

SHKALLA **1:500**

NUMRI I FLETËS **T-245**

2024

AUTORITETI KONTRAKTOR:  
BASHKIA TIRANË



PROJEKTUESI: “NET-GROUP” SH.P.K





0+775.00

CS - 33

0+800.00

CS - 34

0+825.00

CS - 35

0+850.00



CS - 36

0+875.00

CS - 37

0+888.92

LEGJENDA

-  SIPËRFAQE ME ASFALT
-  KUNETË
-  TROTUAR
-  BANKINË
-  MUR I RI
-  KANAL I RI
-  KANAL EKZISTUES
-  GARDH I RI
-  TUB I RI
-  PUSËTË K.U.N
-  LINJË K.U.N

TITULLI I PROJEKTIT

“REHABILITIMI I INFRASTRUKTURËS RRUGORE  
NË NJËSINË ADMINISTRATIVE  
VAQARR - PEZË - NDRUQ”

FAZA

PROJEKT ZBATIM

RRUGA TE BREGU ERZENIT-  
PEZE

EMËRTIMI I FLETËS PLANIMETRIA K.U.N

SHKALLA **1:500**

NUMRI I FLETËS **T-246**

2024

AUTORITETI KONTRAKTOR:  
BASHKIA TIRANË



PROJEKTUESI: “NET-GROUP” SH.P.K



**TITULLI I PROJEKTIT**

“REHABILITIMI I INFRASTRUKTURËS RRUGORE  
NË NJËSINË ADMINISTRATIVE  
VAQARR - PEZË - NDRIQ”

FAZA

PROJEKT ZBATIM

PRERJA 1-1 SHK.1:50

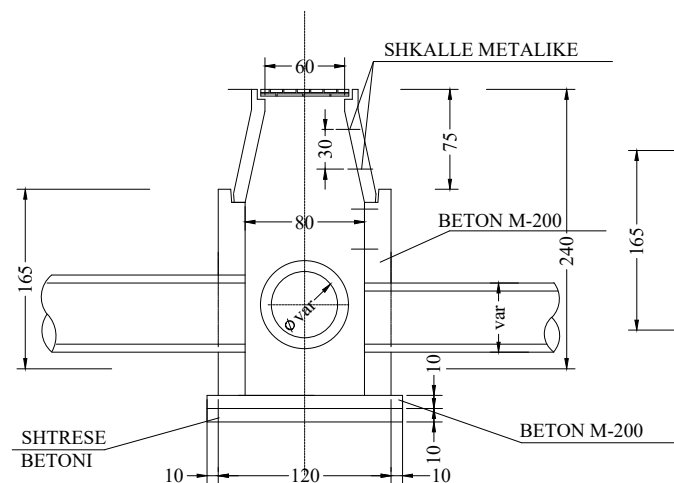

PLAN SHK.1:50

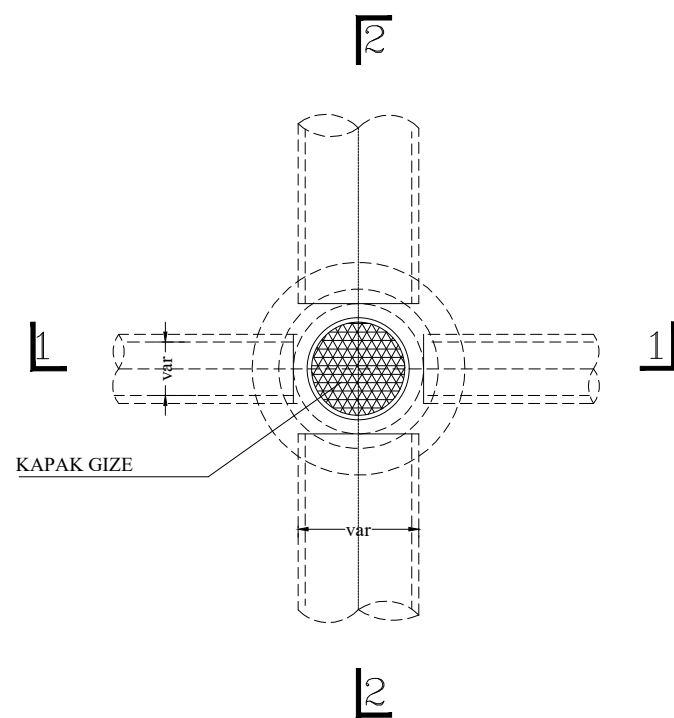

PRERJA 2-2 SHK.1:50

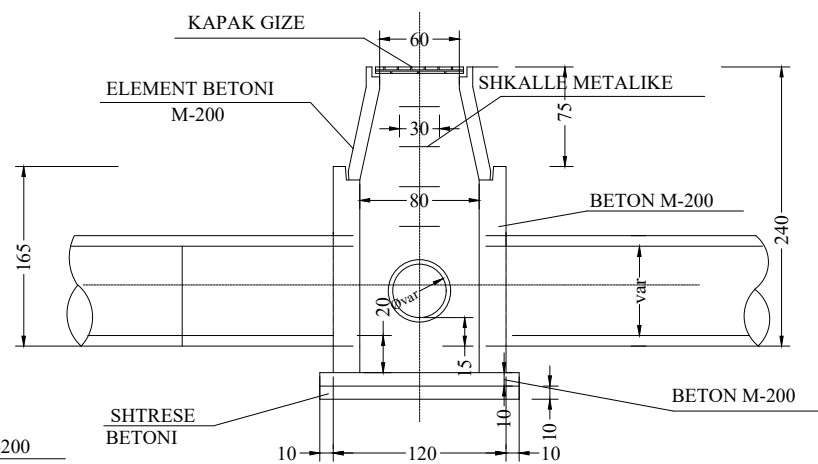

SPIRALI JASHEM SHK.1:20

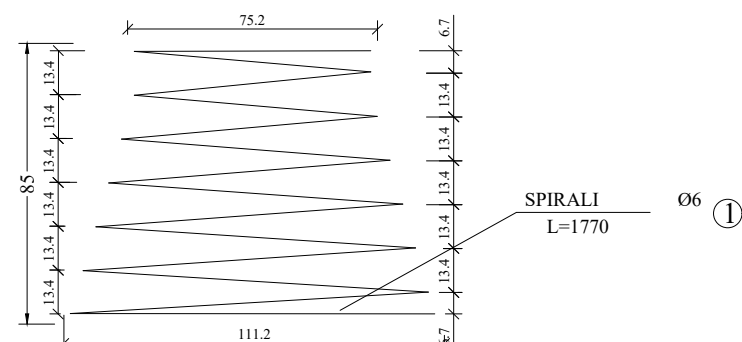

SPIRALI BRENDESEM SHK.1:20

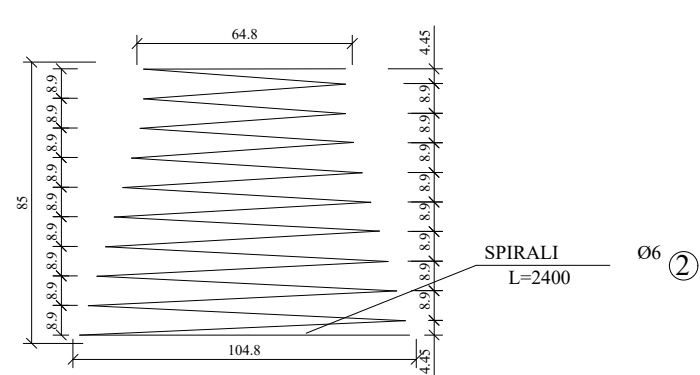

ELEMENT BETONI SHK.1:20

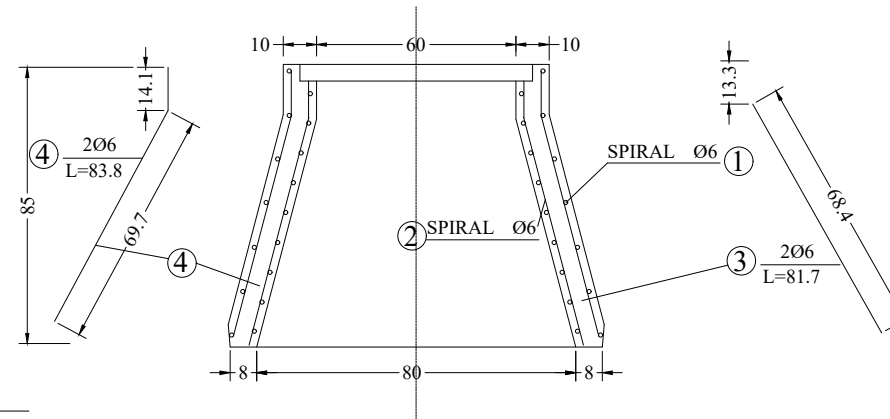

PLAN SHK.1:20

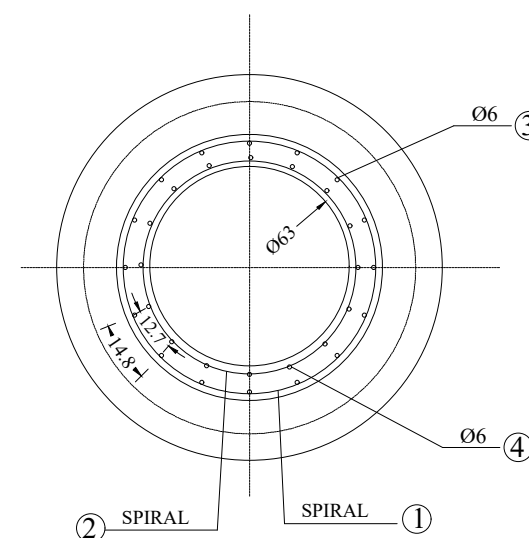

EMËRTIMI I FLETËS DETAJE K.U.N

SHKALLA

NUMRI I FLETËS **T-247**

2024

AUTORITETI KONTRAKTOR:  
BASHKIA TIRANË



PROJEKTUESI: "NET-GROUP" SH.P.K



TITULLI I PROJEKTIT

“REHABILITIMI I INFRASTRUKTURËS RRUGORE  
NË NJËSINË ADMINISTRATIVE  
VAQARR - PEZË - NDRIQ”

FAZA

PROJEKT ZBATIM

PRERJE TERTHORE KANALI  
Tubacion PEHD i brinjezuar DN 400 mm  
SH 1:20

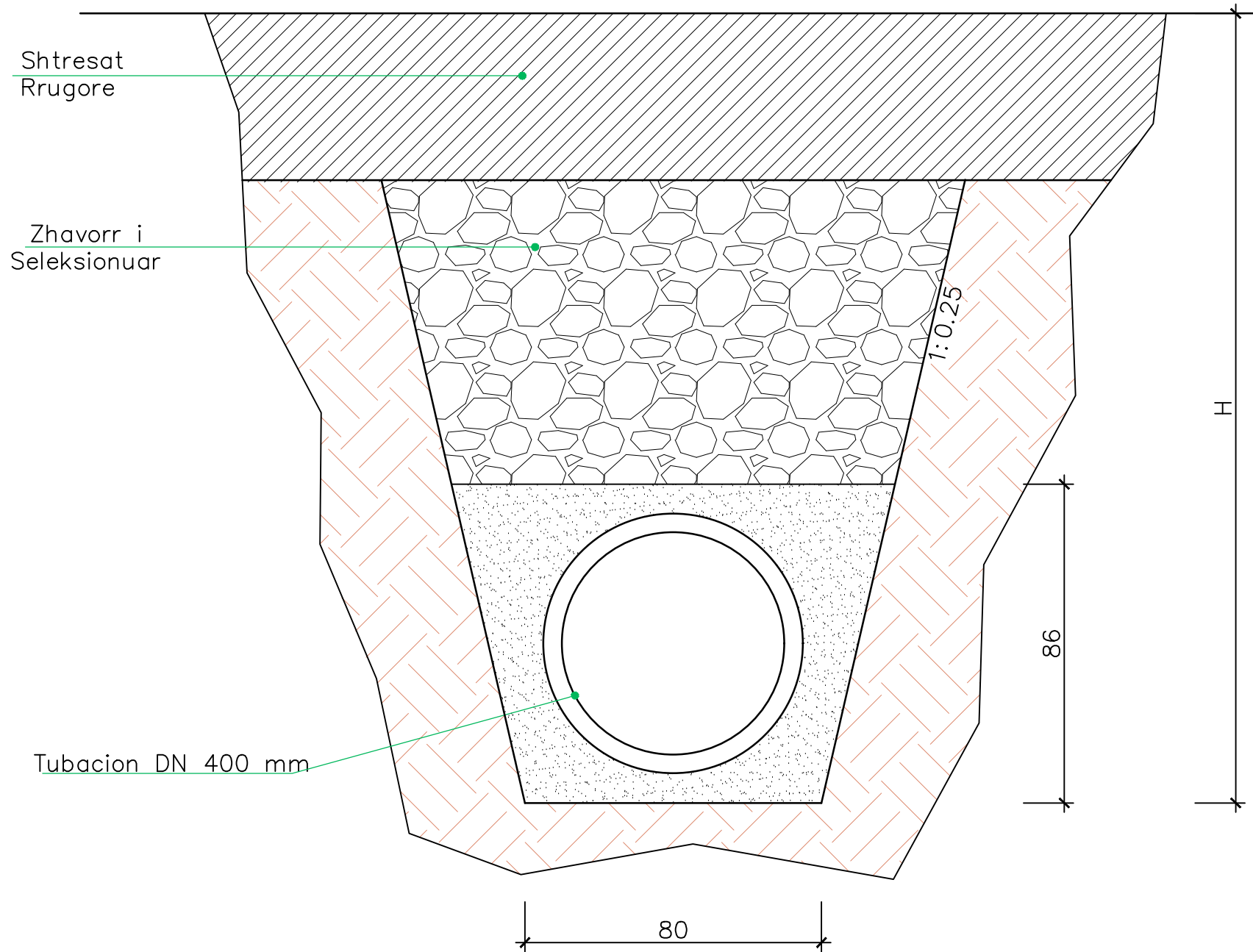

EMËRTIMI I FLETËS    DETAJEKUJN

SHKALLA

NUMRI I FLETËS    **T-248**

2024

AUTORITETI KONTRAKTOR:  
BASHKIA TIRANË



PROJEKTUESI: "NET-GROUP" SH.P.K



TITULLI I PROJEKTIT

“REHABILITIMI I INFRASTRUKTURËS RRUGORE  
NË NJËSINË ADMINISTRATIVE  
VAQARR - PEZË - NDRIQ”

FAZA

PROJEKT ZBATIM

Prerja Gjatësore e Tombinos Rrethore Tip Ø1000mm - Sh.1:50

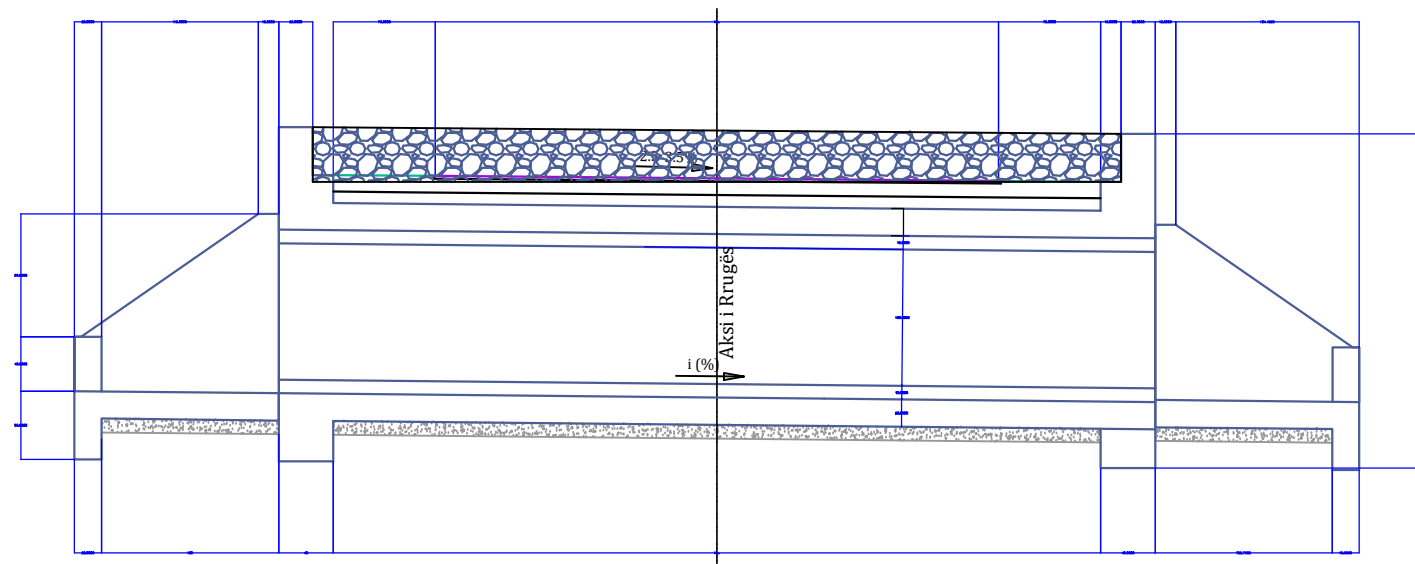

Prerja Tërthore e Tombinos Rrethore Tip Ø1000mm - Sh.1:50

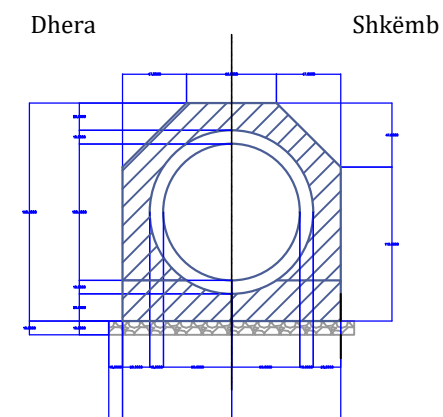

Pamja Plane e Tombinos Rrethore Tip Ø1000mm - Sh.1:50

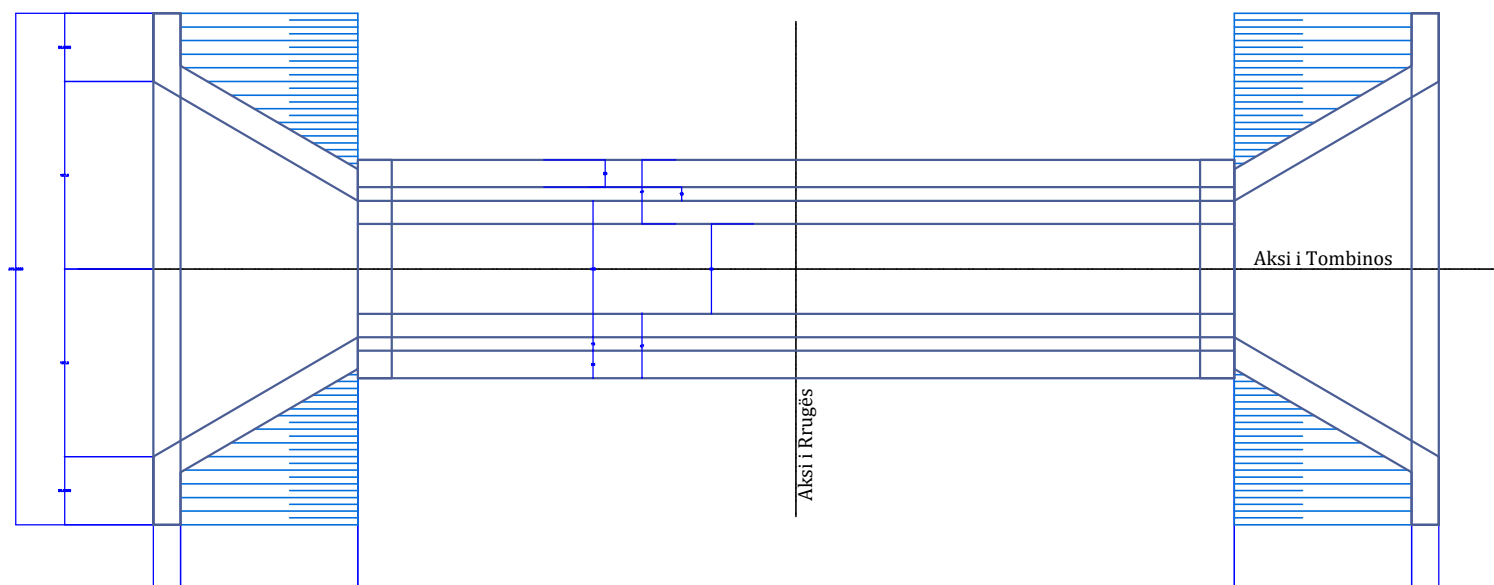

Pamja Ballore e Tombinos Rrethore Tip Ø1000mm - Sh.1:50

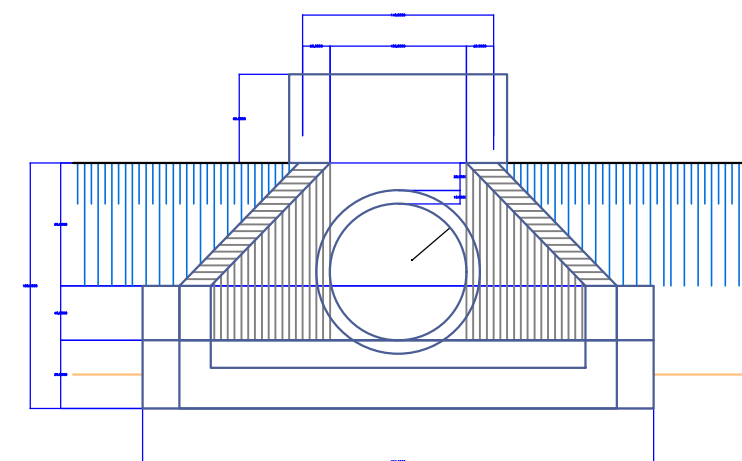

EMËRTIMI I FLETËS    DETAJE K.U.SH

SHKALLA

NUMRI I FLETËS    **T-249**

2024

AUTORITETI KONTRAKTOR:  
BASHKIA TIRANË



PROJEKTUESI: "NET-GROUP" SH.P.K

