

RRUGA "KOZAR"

LEGJENDA:

- Vija e Asfalti (aksi i rruges)
- Mur Mbajtes

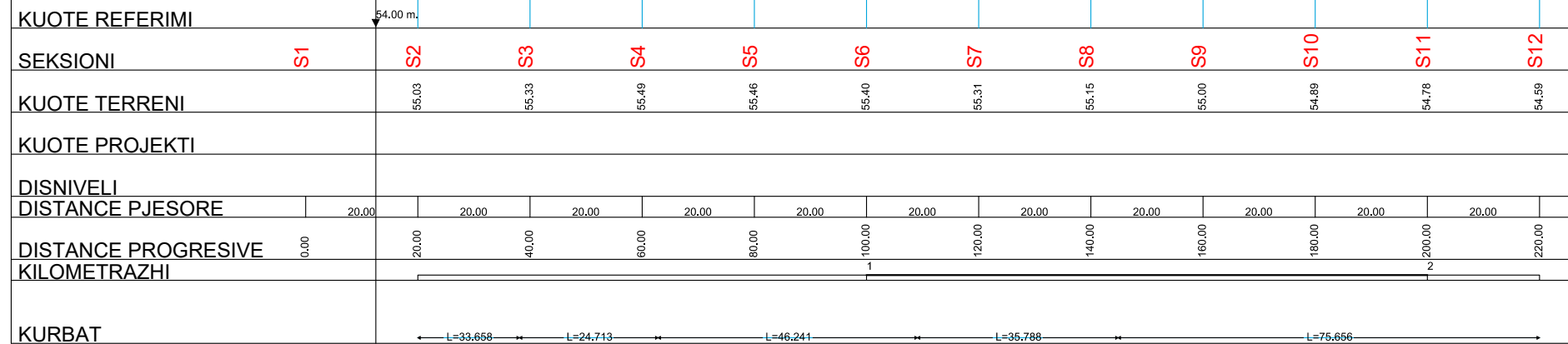
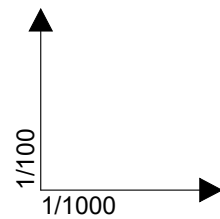

BASHKIA KAMEZ

DREJTORIA E SHERBIMEVE PUBLIKE
DREJTORIA E PROJEKTEVE DHE INVESTIMEVE
DEPARTAMENTI I PROJEKTEVE

Dr. e Projekteve e Investimeve	FLORA MUCA
STAFI TEKNIK PROJEKTES	Ing. ARJOLA KURTI
	Ing. ERBLIN LALA
	Ing. DENIS PRENCI
	Ing. RAMADAN HYSA

<p>Titulli i Projektit RIKONSTRUKSION RRUGA "LUNXHERI", NDERTIM RRUGA PARALEL ME RR "LUNXHERI", PINGUL ME RR "DURRESI", PINGUL ME RR "LURA", RRUGA "KORCE", MUR MBAJTES RRUGA "KOZAR"</p> <p>Emertimi i Fletes PROFILI GJATESOR I RRUGES</p>	<p>Faza e Projektit PROJEKT ZBATIMI</p> <p>Data e Implementimit :</p> <p>Shkalla e Vizatimit H-1:1000 V-1:100</p> <p>Fleta Nr. 06</p>
--	--



BASHKIA KAMEZ

PROJEKT ZBATIMI

OBJEKTI:

RIKONSTRUKSION RRUGA "LUNXHERI", NDERTIM RRUGA PARALEL ME RR "LUNXHERI", PINGUL ME RR "DURRESI", PINGUL ME RR "LURA", RRUGA "KORCE", MUR MBAJTES RRUGA "KOZAR"

PROFILET TERTHORE



BASHKIA KAMEZ

DREJTORIA E SHERBIMEVE PUBLIKE
DREJTORIA E PROJEKTEVE DHE INVESTIMEVE
DEPARTAMENTI I PROJEKTEVE

Dr. e Projekteve e Investimeve		FLORA MUCA
STAFI TEKNIK PROJEKTES	Ing.	ARJOLA KURTI
	Ing.	ERBLIN LALA
	Ing.	DENIS PRENCI
	Ing.	RAMADAN HYSA

<small>Titulli i Projektit</small> RIKONSTRUKSION RRUGA "LUNXHERI", NDERTIM RRUGA PARALEL ME RR "LUNXHERI", PINGUL ME RR "DURRESI", PINGUL ME RR "LURA", RRUGA "KORCE", MUR MBAJTES RRUGA "KOZAR"	<small>Faza e Projektit</small> PROJEKT ZBATIMI
<small>Emertimi i Pletes</small> KAPAK	<small>Data e Implementimit:</small>
	<small>Shkalla e Vizimit</small>
	<small>Plota Nr.</small>

Rr. Lunxheri
Seksioni - S1
Pr. 0.00 ml
Kt= 51.65 ml
Kp= 51.65 ml
Gr= 1.00 m2
Mb= 0.02 m2

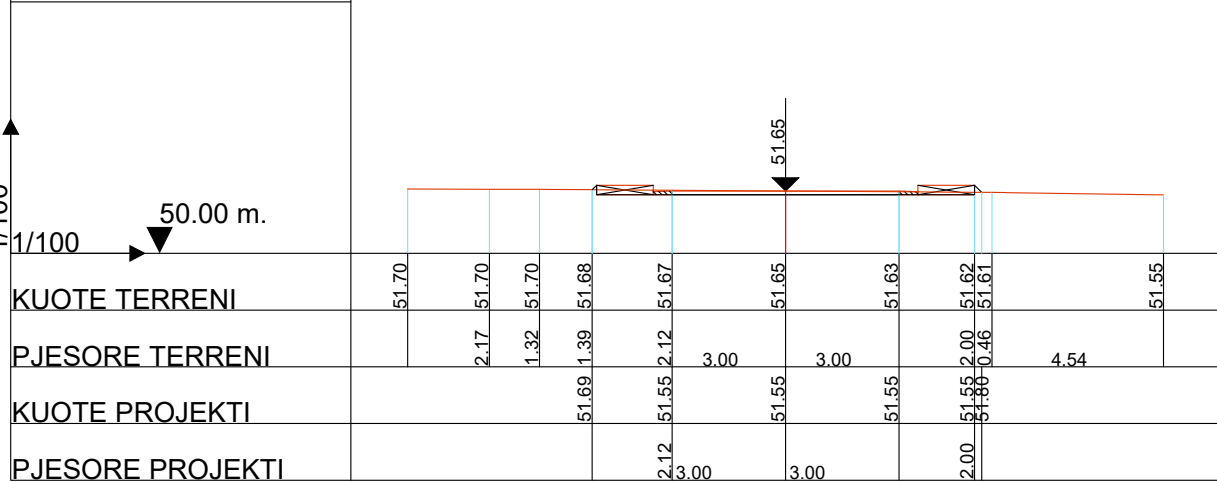

Rr. Lunxheri
Seksioni - S2
Pr. 20.00 ml
Kt= 51.76 ml
Kp= 51.76 ml
Gr= 1.11 m2
Mb= 0.00 m2

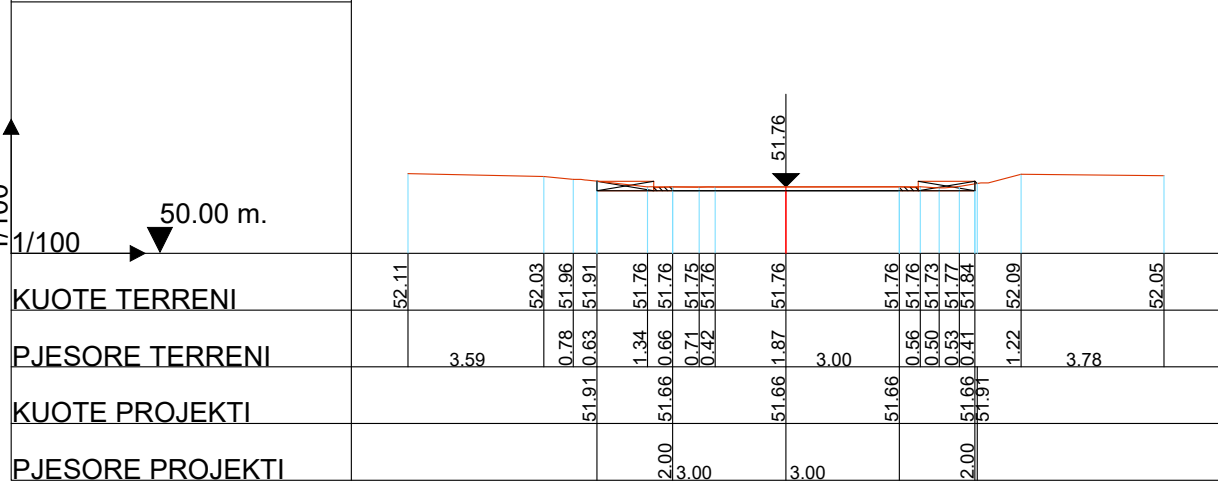

Rr. Lunxheri
Seksioni - S3
Pr. 40.00 ml
Kt= 51.87 ml
Kp= 51.87 ml
Gr= 1.12 m2
Mb= 0.00 m2

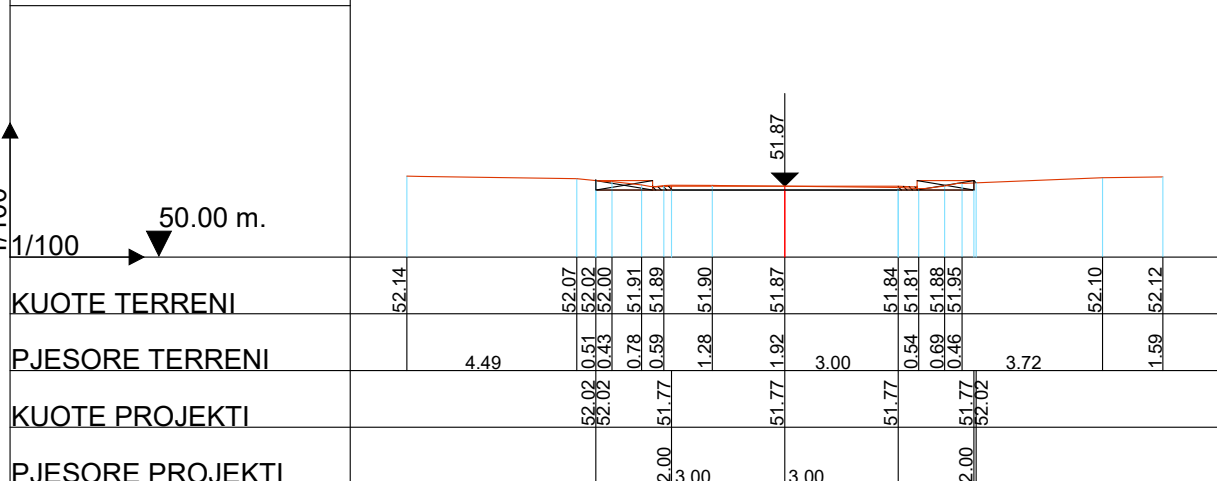

Rr. Lunxheri
Seksioni - S4
Pr. 60.00 ml
Kt= 51.98 ml
Kp= 51.98 ml
Gr= 1.23 m2
Mb= 0.00 m2

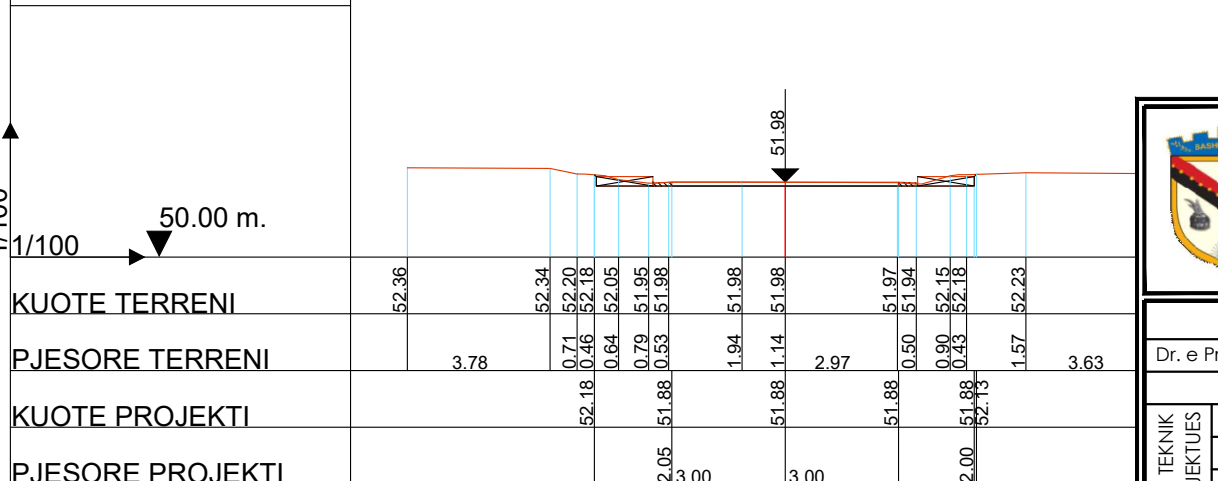

BASHKIA KAMEZ
 DREJTORIA E SHERBIMEVE PUBLIKE
 DREJTORIA E PROJEKTEVE DHE INVESTIMEVE
 DEPARTAMENTI I PROJEKTEVE

Dr. e Projekteve e Investimeve	FLORA MUCA
--------------------------------	------------

STAFI TEKNIK PROJEKTES	Ing. ARJOLA KURTI
	Ing. ERBLIN LALA
	Ing. DENIS PRENCI
	Ing. RAMADAN HYSA

Titulli i Projektit	RIKONSTRUKSION RRUGA "LUNXHERI", NDERTIM RRUGA PARALEL ME RR "LUNXHERI", PINGUL ME RR "DURRESI", PINGUL ME RR "LURA", RRUGA "KORCE", MUR MBAJTES RRUGA "KOZAR"
Faza e Projektit	PROJEKT ZBATIMI
Data e Implementimit	

Shkalla e Vizatimit	1:200
Emertimi i Fletes	PROFLET TERTHORE
Fieta Nr.	01

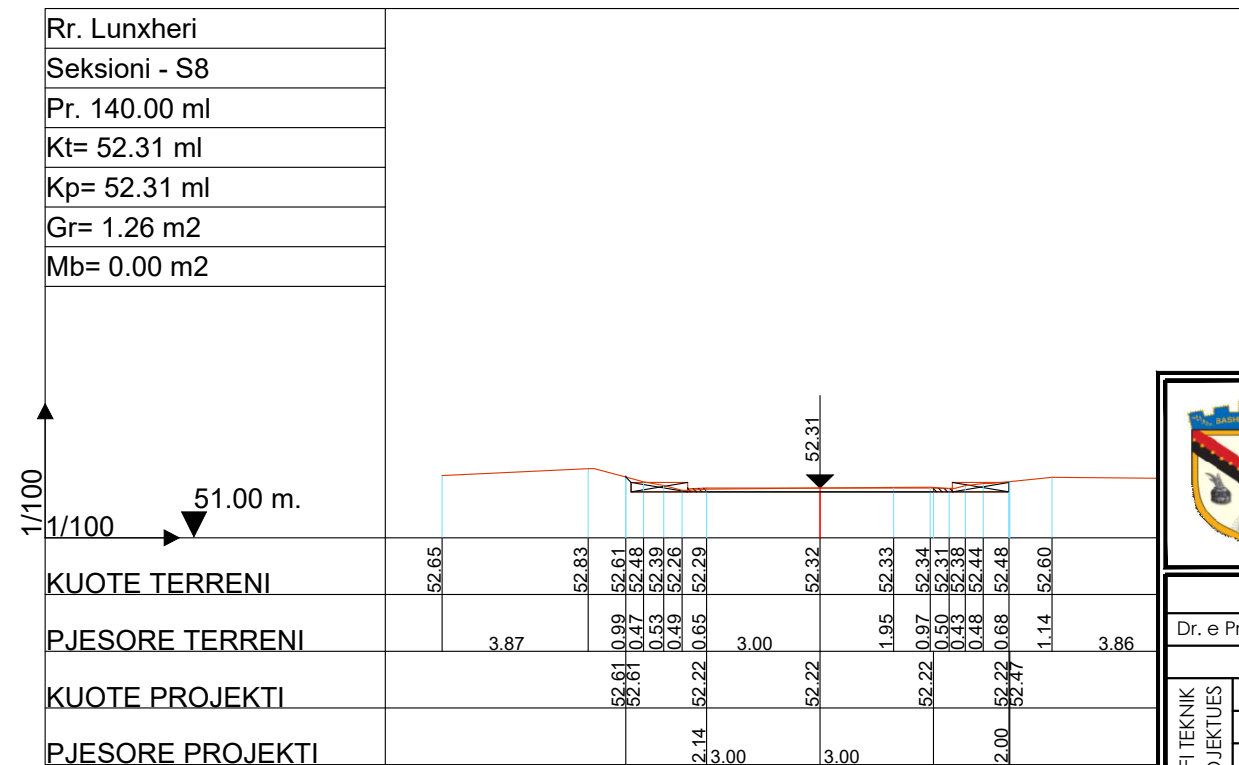
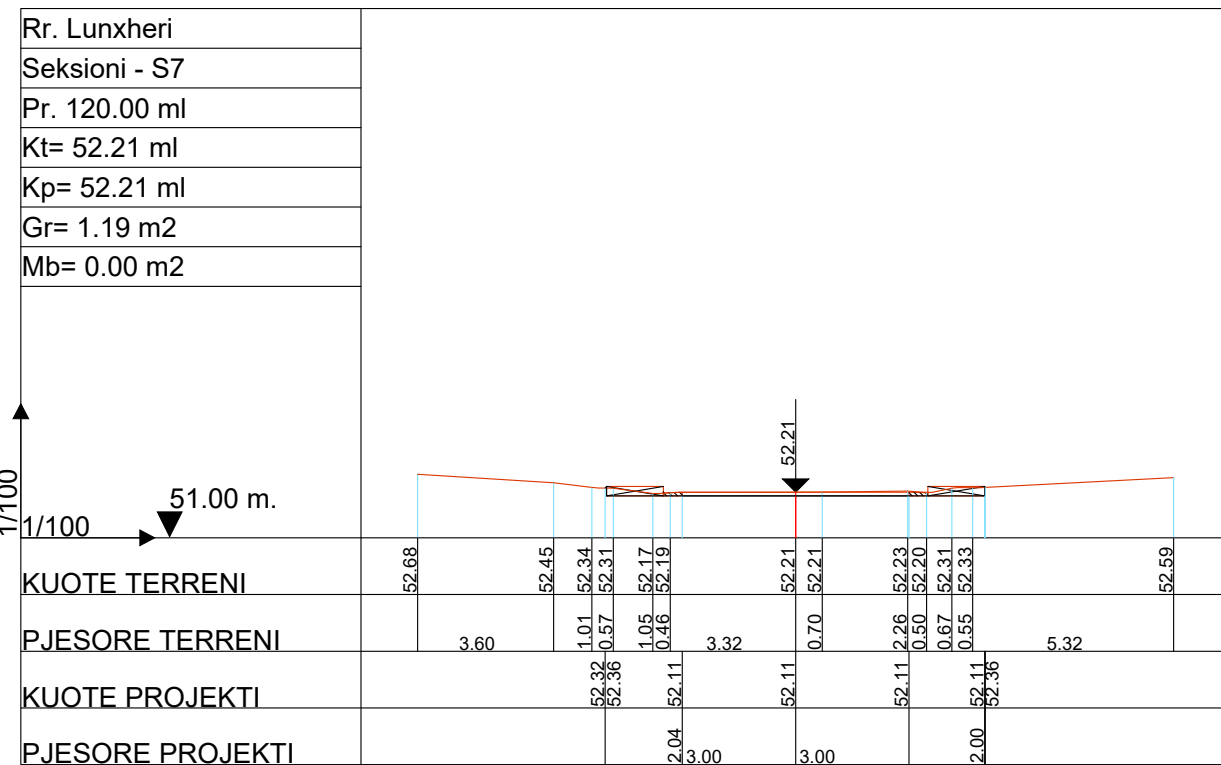
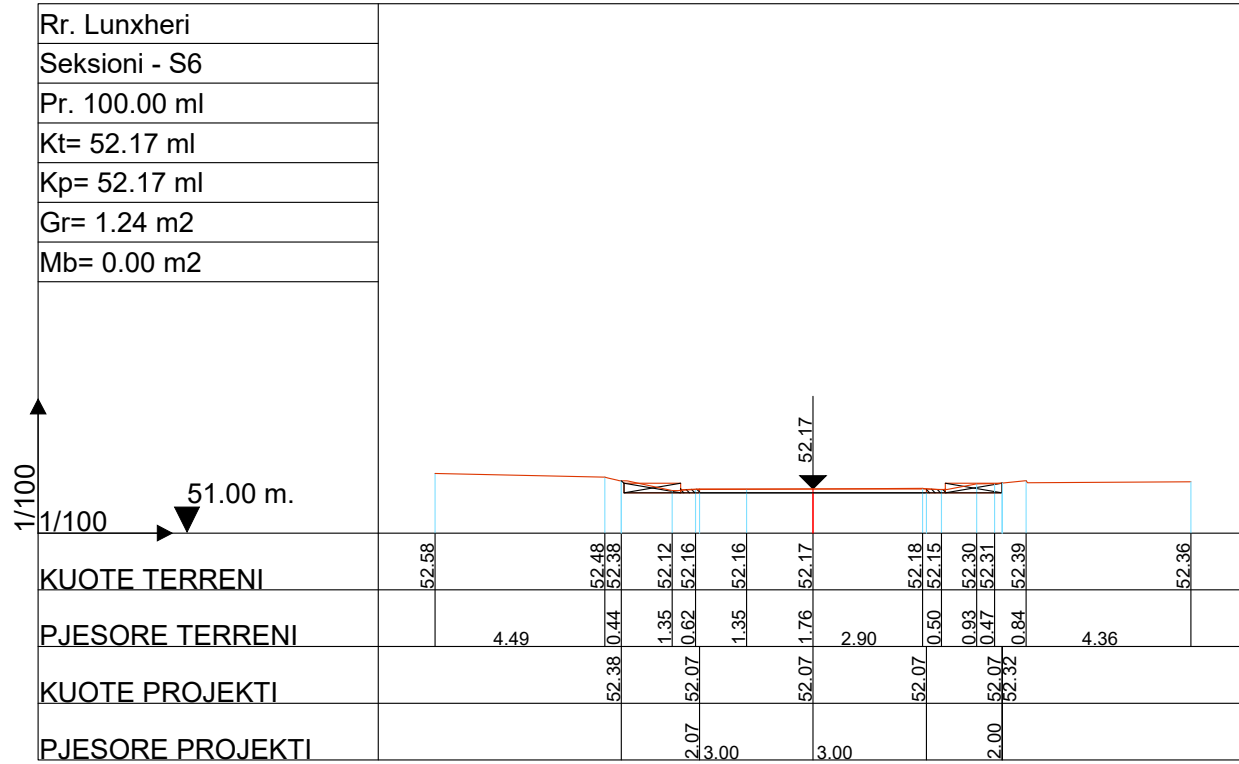
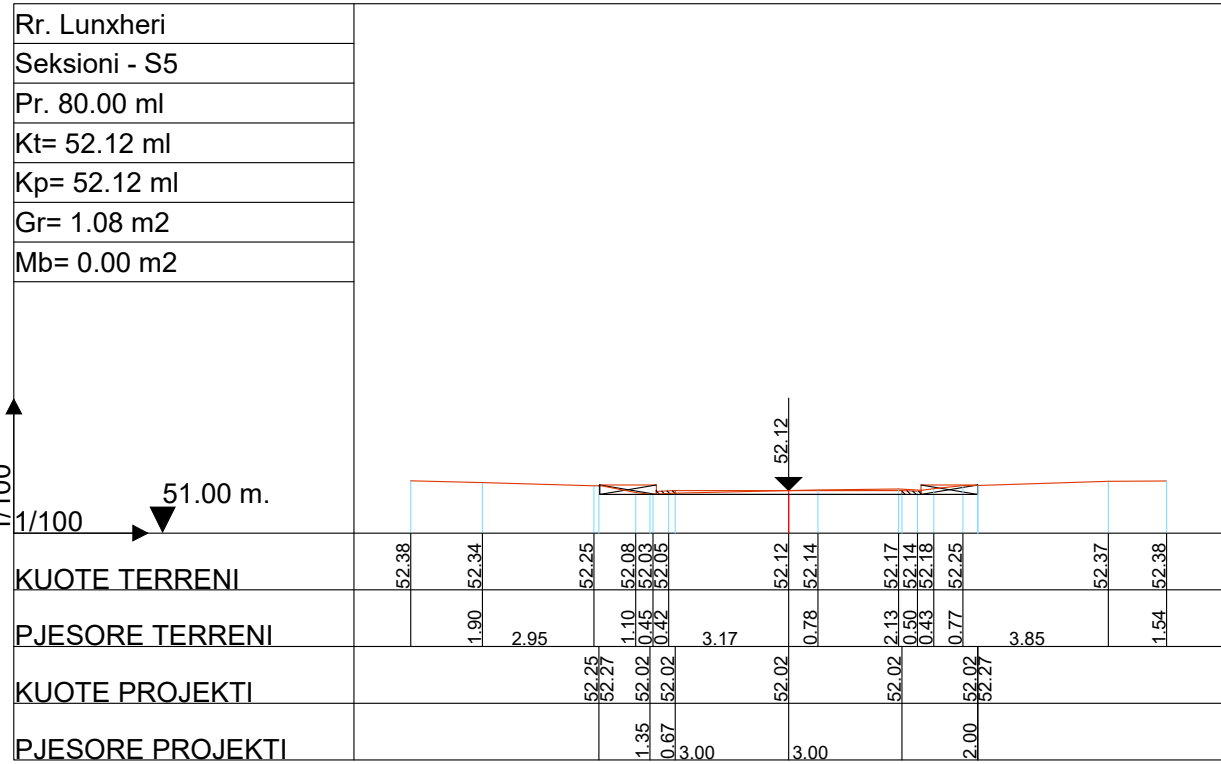



BASHKIA KAMEZ

DREJTORIA E SHERBIMEVE PUBLIKE
DREJTORIA E PROJEKTEVE DHE INVESTIMEVE
DEPARTAMENTI I PROJEKTEVE

Dr. e Projekteve e Investimeve	FLORA MUCA
--------------------------------	------------

STAFI TEKNIK PROJEKTUES	Ing.	ARJOLA KURTI
	Ing.	ERBLIN LALA
	Ing.	DENIS PRENCI
	Ing.	RAMADAN HYSA

Titulli i Projektit RIKONSTRUKSION RRUGA "LUNXHERI", NDERTIM RRUGA PARALEL ME RR "LUNXHERI", PINGUL ME RR "DURRESI", PINGUL ME RR "LURA", RRUGA "KORCE", MUR MBAJTES RRUGA "KOZAR"	Faza e Projektit PROJEKT ZBATIMI
Emertimi i Fletes PROFILET TERTHORE	Data e Implementimit : Shkalla e Vizatimit 1:200 Fieta Nr. 02

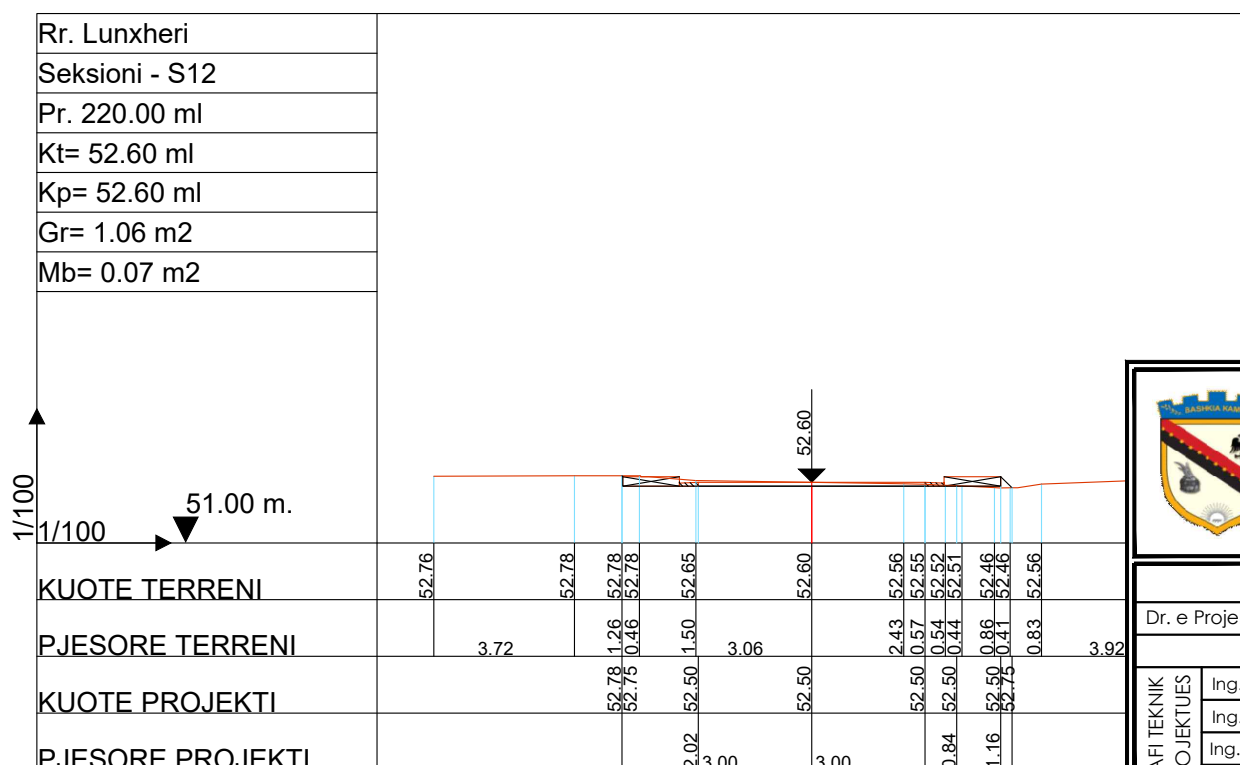
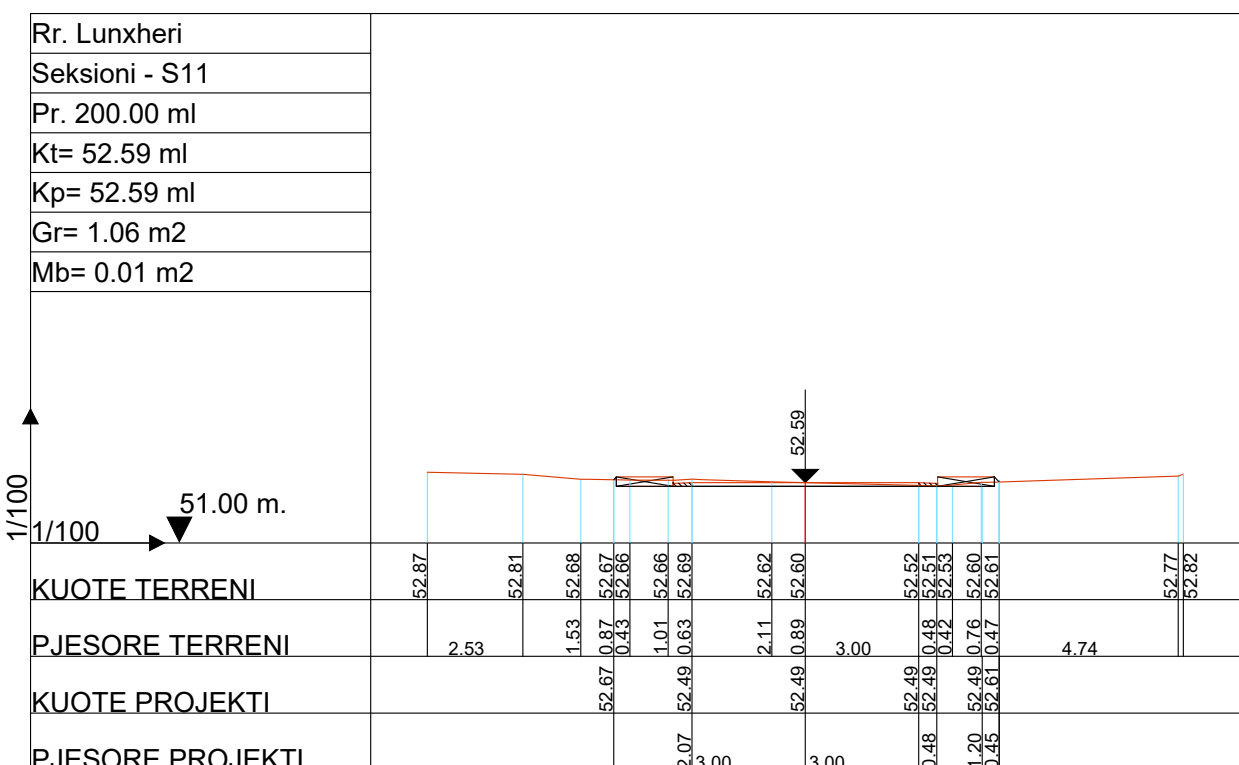
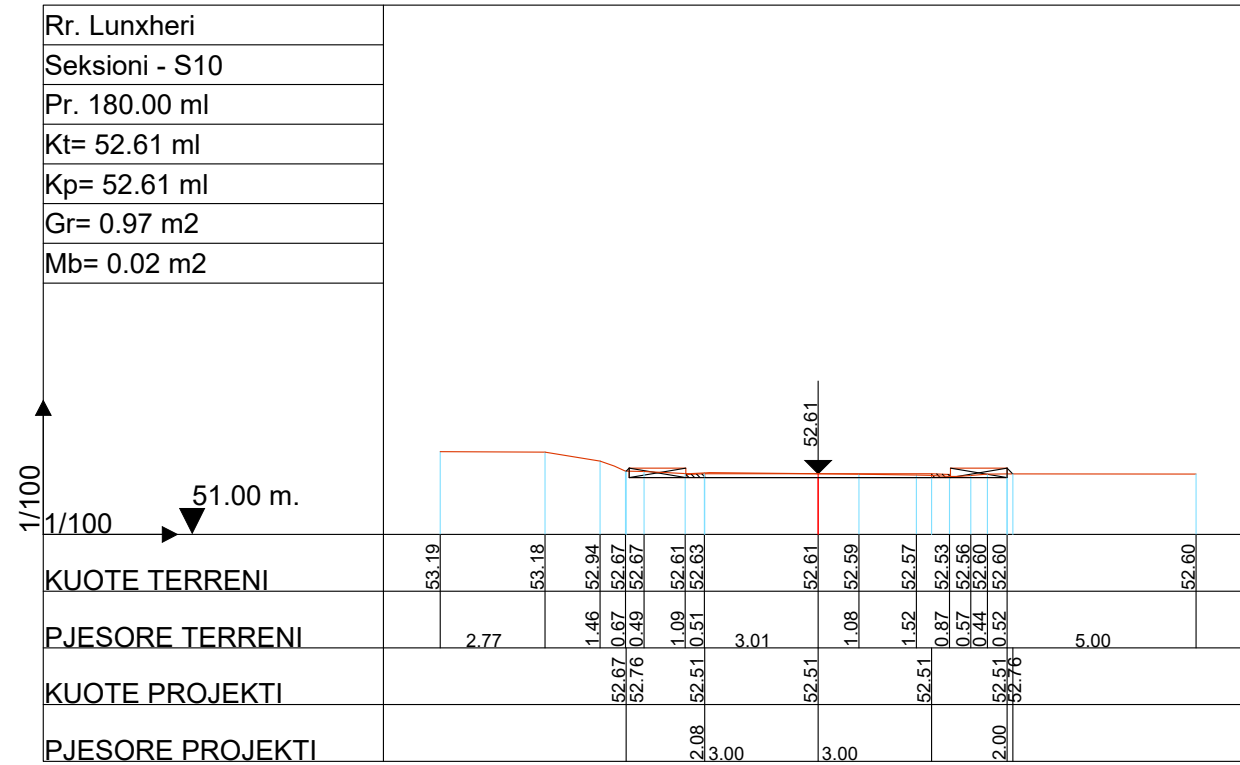
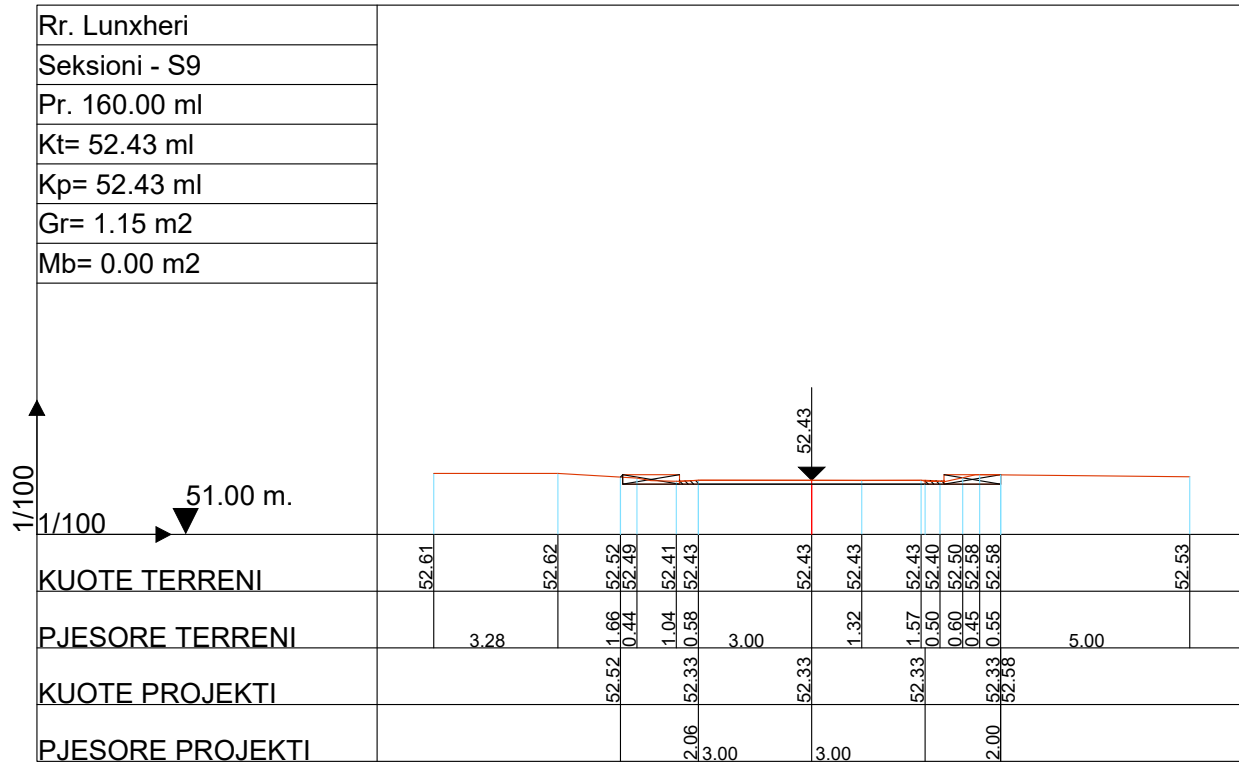

BASHKIA KAMEZ

DREJTORIA E SHERBIMEVE PUBLIKE
DREJTORIA E PROJEKTEVE DHE INVESTIMEVE
DEPARTAMENTI I PROJEKTEVE

Dr. e Projekteve e Investimeve	FLORA MUCA
--------------------------------	------------

STAFI TEKNIK	Ing.	ARJOLA KURTI
	Ing.	ERBLIN LALA
	Ing.	DENIS PRENCI
	Ing.	RAMADAN HYSA

Titulli i Projektit	Faza e Projektit
RIKONSTRUKSION RRUGA "LUNXHERI", NDERTIM RRUGA PARALEL ME RR "LUNXHERI", PINGUL ME RR "DURRESI", PINGUL ME RR "LURA", RRUGA "KORCE", MUR MBAJTES RRUGA "KOZAR"	PROJEKT ZBATIMI
Emertimi i Fletes	Data e Implementimit :
PROFILET TERTHORE	Shkalla e Vizatimit
	1:200
	Fieta Nr.
	03

Rr. Lunxheri
Seksioni - S13
Pr. 240.00 ml
Kt= 52.72 ml
Kp= 52.72 ml
Gr= 1.01 m2
Mb= 0.01 m2

Rr. Lunxheri
Seksioni - S14
Pr. 260.00 ml
Kt= 52.77 ml
Kp= 52.77 ml
Gr= 0.82 m2
Mb= 0.18 m2

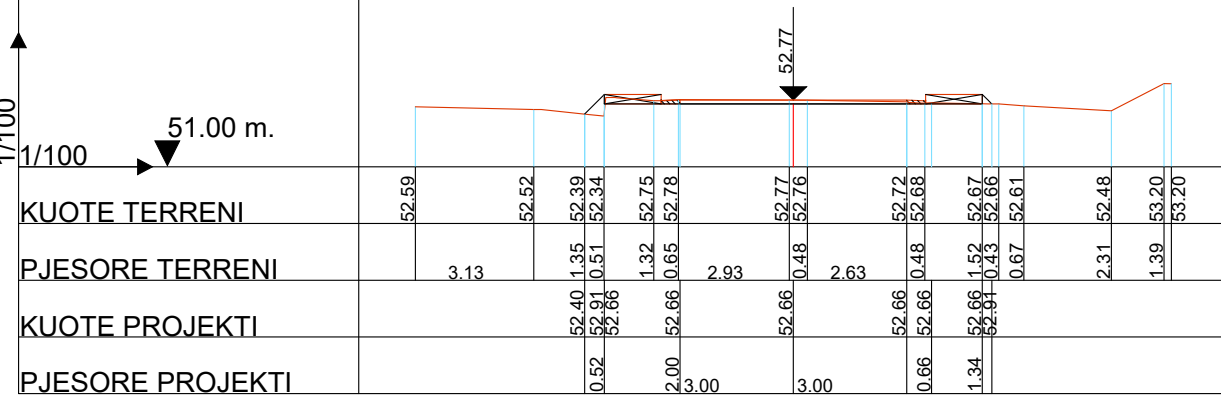
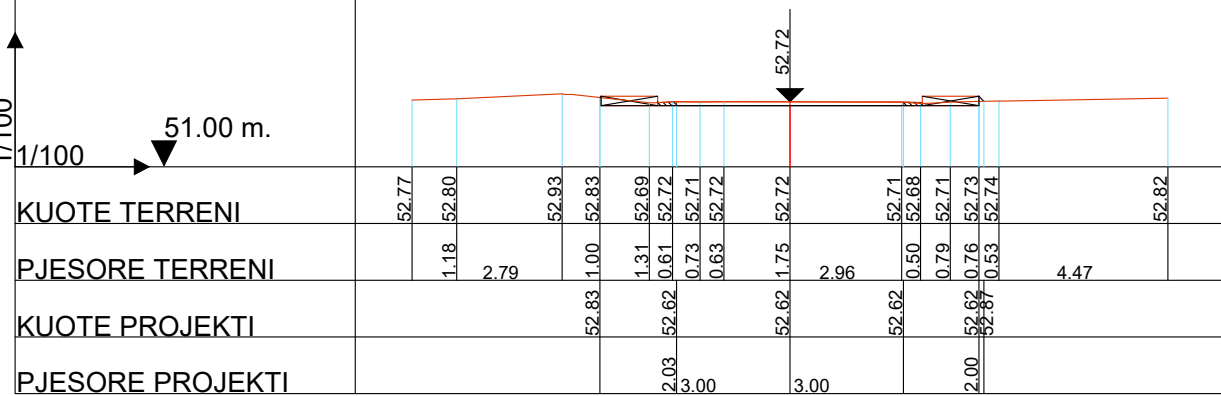

Rr. Lunxheri
Seksioni - S15
Pr. 280.00 ml
Kt= 52.85 ml
Kp= 52.85 ml
Gr= 0.90 m2
Mb= 0.22 m2

Rr. Lunxheri
Seksioni - S16
Pr. 300.00 ml
Kt= 52.85 ml
Kp= 52.85 ml
Gr= 1.10 m2
Mb= 0.20 m2

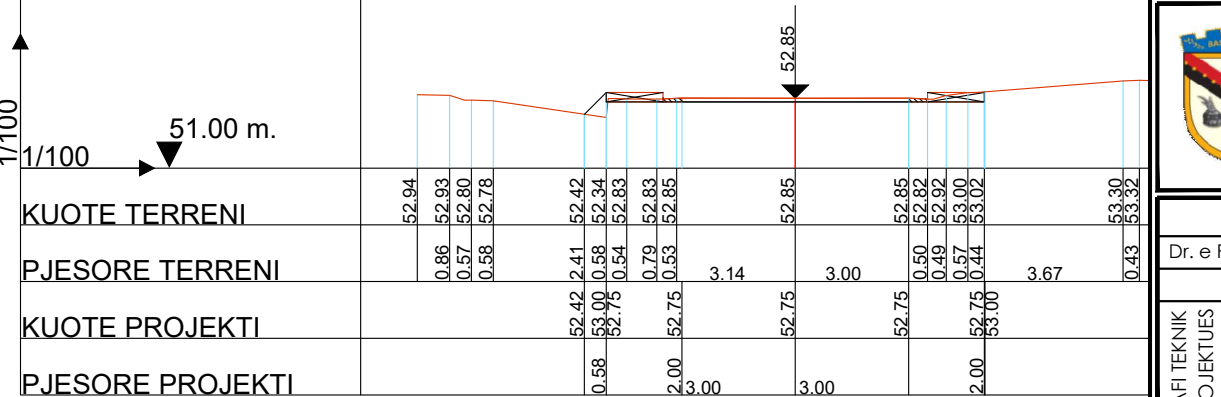
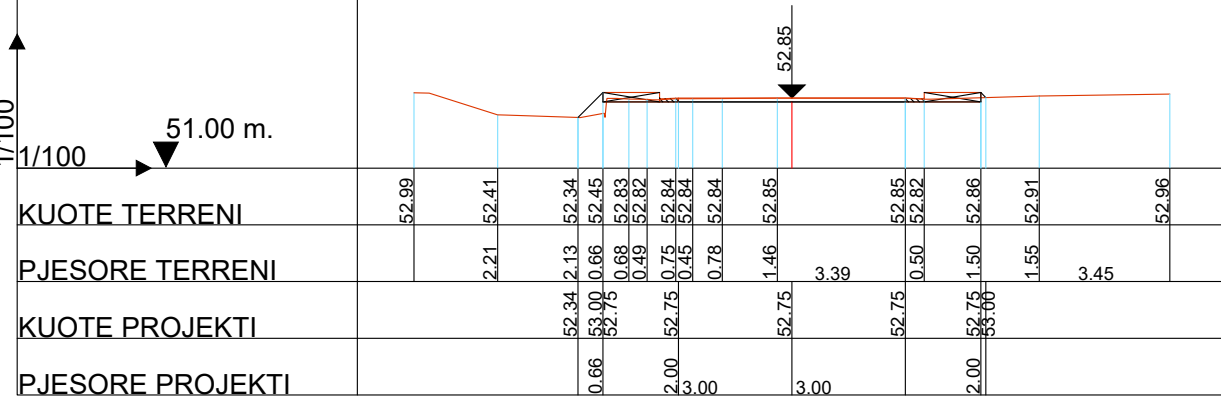

BASHKIA KAMEZ
 DREJTORIA E SHERBIMEVE PUBLIKE
 DREJTORIA E PROJEKTEVE DHE INVESTIMEVE
 DEPARTAMENTI I PROJEKTEVE

Dr. e Projekteve e Investimeve	FLORA MUCA
STAFI TEKNIK PROJEKTES	Ing. ARJOLA KURTI Ing. ERBLIN LALA Ing. DENIS PRENCI Ing. RAMADAN HYSA

Titulli i Projektit	RIKONSTRUKSION RRUGA "LUNXHERI", NDERTIM RRUGA PARALEL ME RR "LUNXHERI", PINGUL ME RR "DURRESI", PINGUL ME RR "LURA", RRUGA "KORCE", MUR MBAJTES RRUGA "KOZAR"
Faza e Projektit	PROJEKT ZBATIMI
Data e Implementimit	
Shkalla e Vizatimit	1:200
Emertimi i Fletes	PROFLET TERTHORE
Fieta Nr.	04

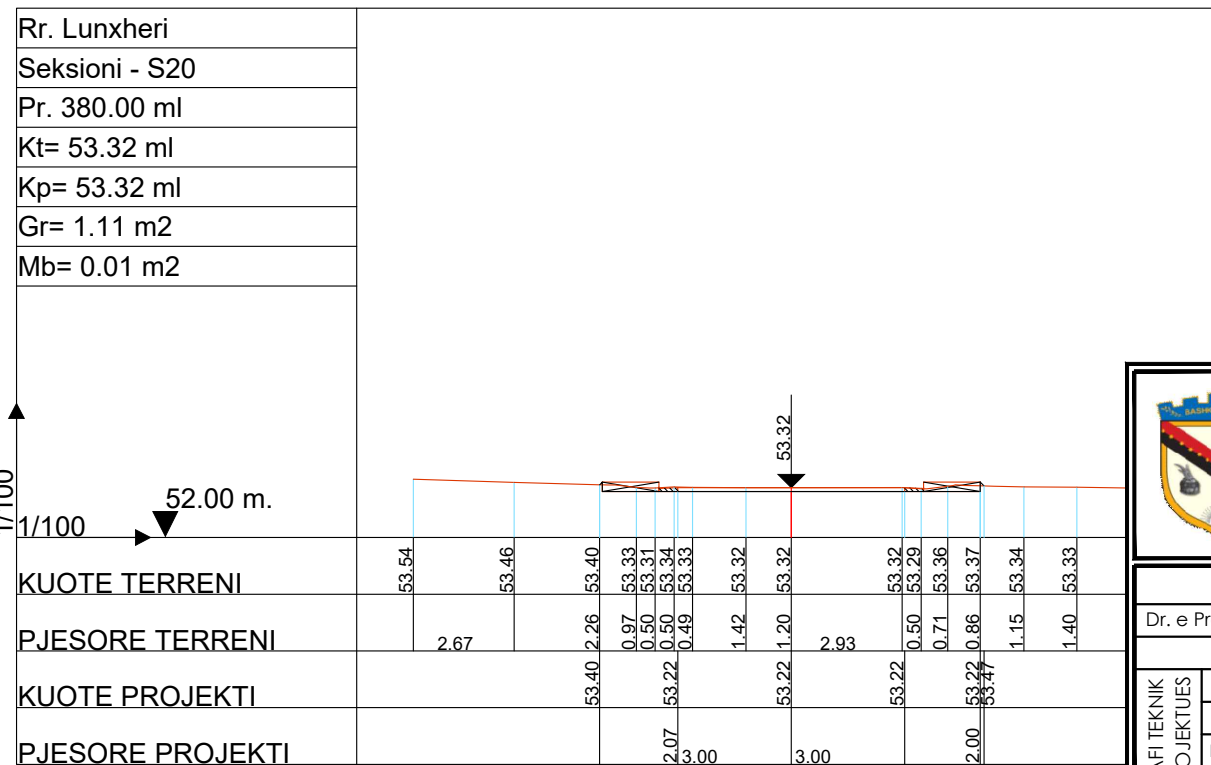
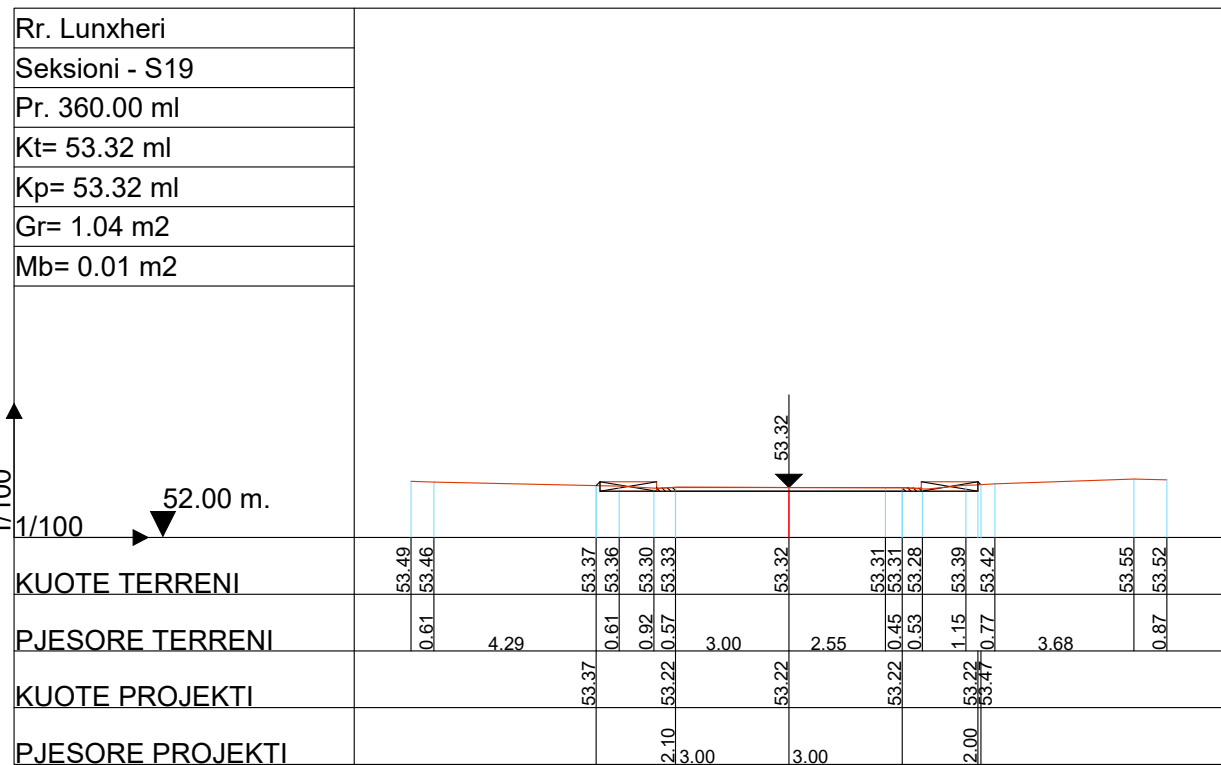
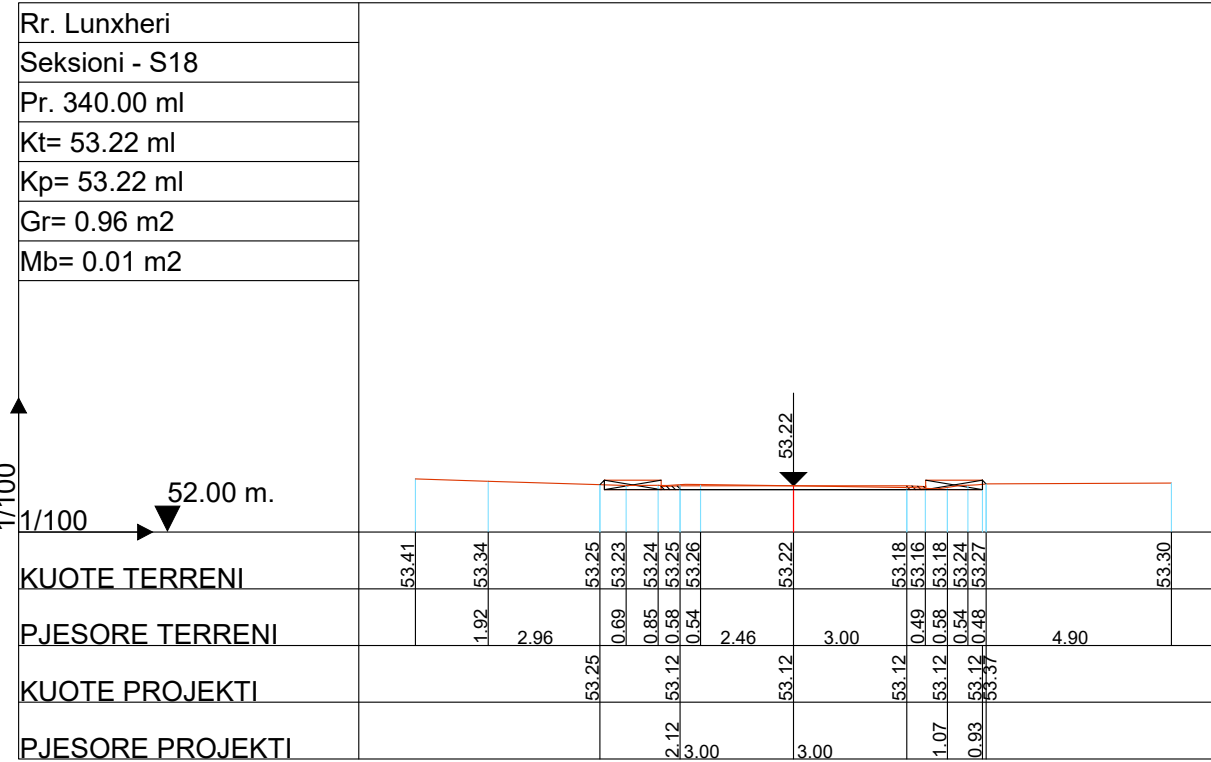
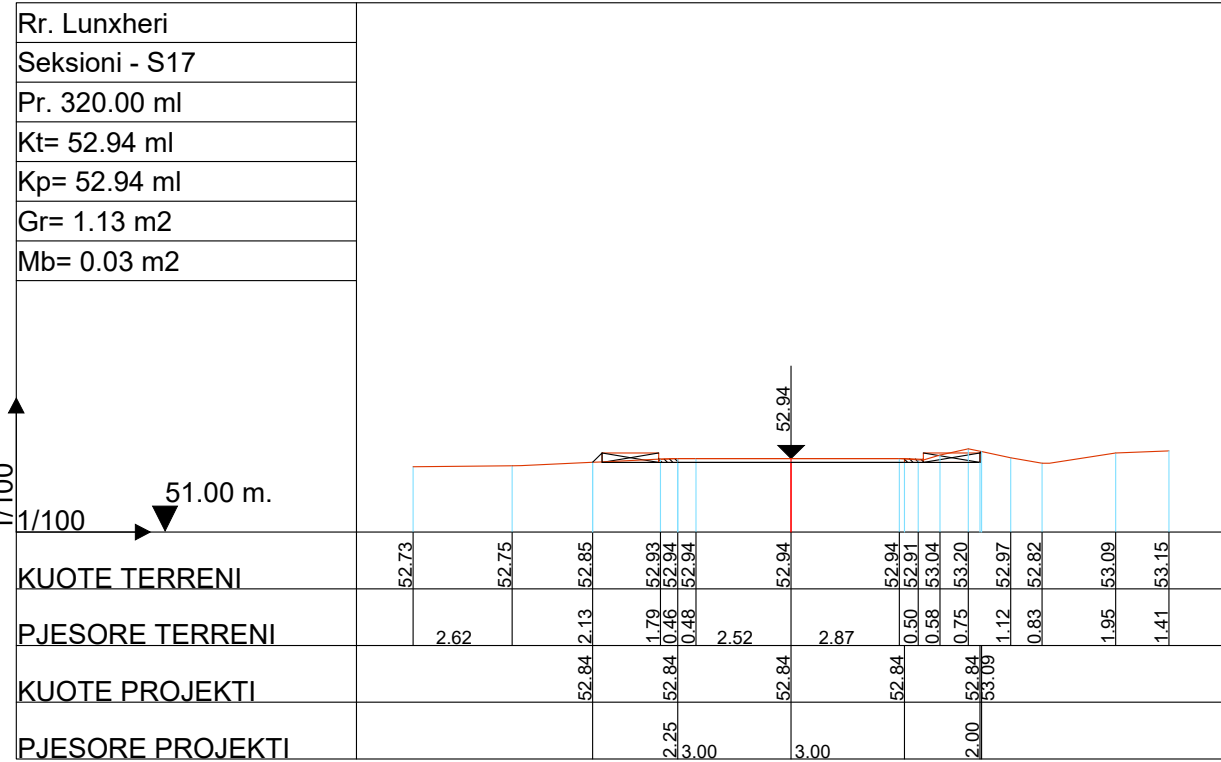

BASHKIA KAMEZ
DREJTORIA E SHERBIMEVE PUBLIKE
DREJTORIA E PROJEKTEVE DHE INVESTIMEVE
DEPARTAMENTI I PROJEKTEVE

Dr. e Projekteve e Investimeve	FLORA MUCA
STAFI TEKNIK PROJEKTES	Ing. ARJOLA KURTI Ing. ERBLIN LALA Ing. DENIS PRENCI Ing. RAMADAN HYSA

Titulli i Projektit	RIKONSTRUKSION RRUGA "LUNXHERI", NDERTIM RRUGA PARALEL ME RR "LUNXHERI", PINGUL ME RR "DURRESI", PINGUL ME RR "LURA", RRUGA "KORCE", MUR MBAJTES RRUGA "KOZAR"
Faza e Projektit	PROJEKT ZBATIMI
Data e Implementimit	
Shkalla e Vizatimit	1:200
Emertimi i Fletes	PROFLET TERTHORE
Fieta Nr.	05

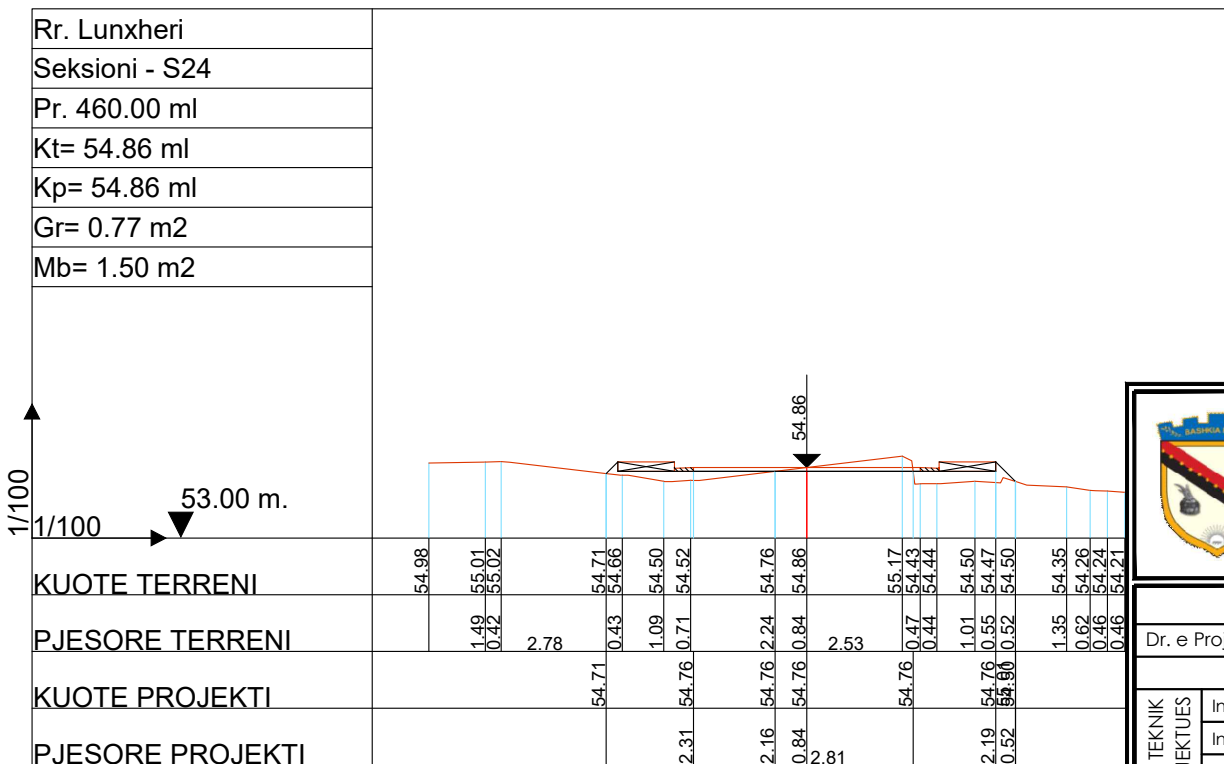
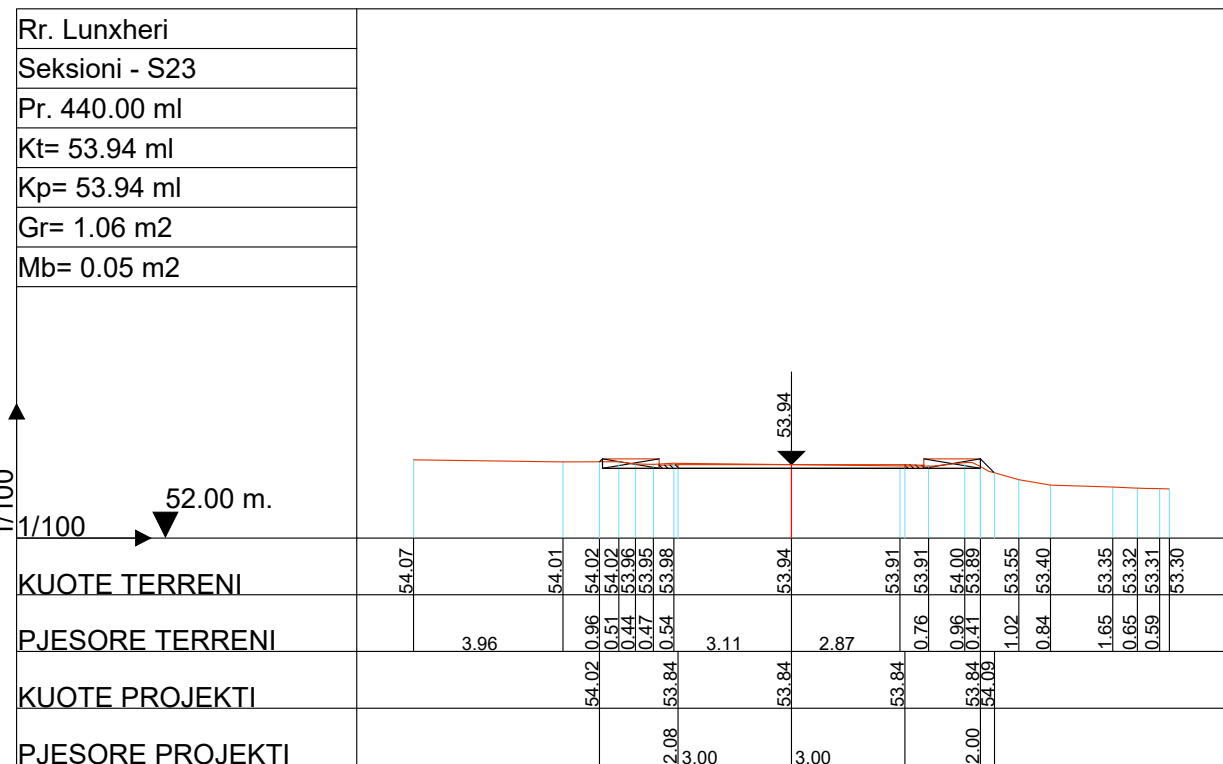
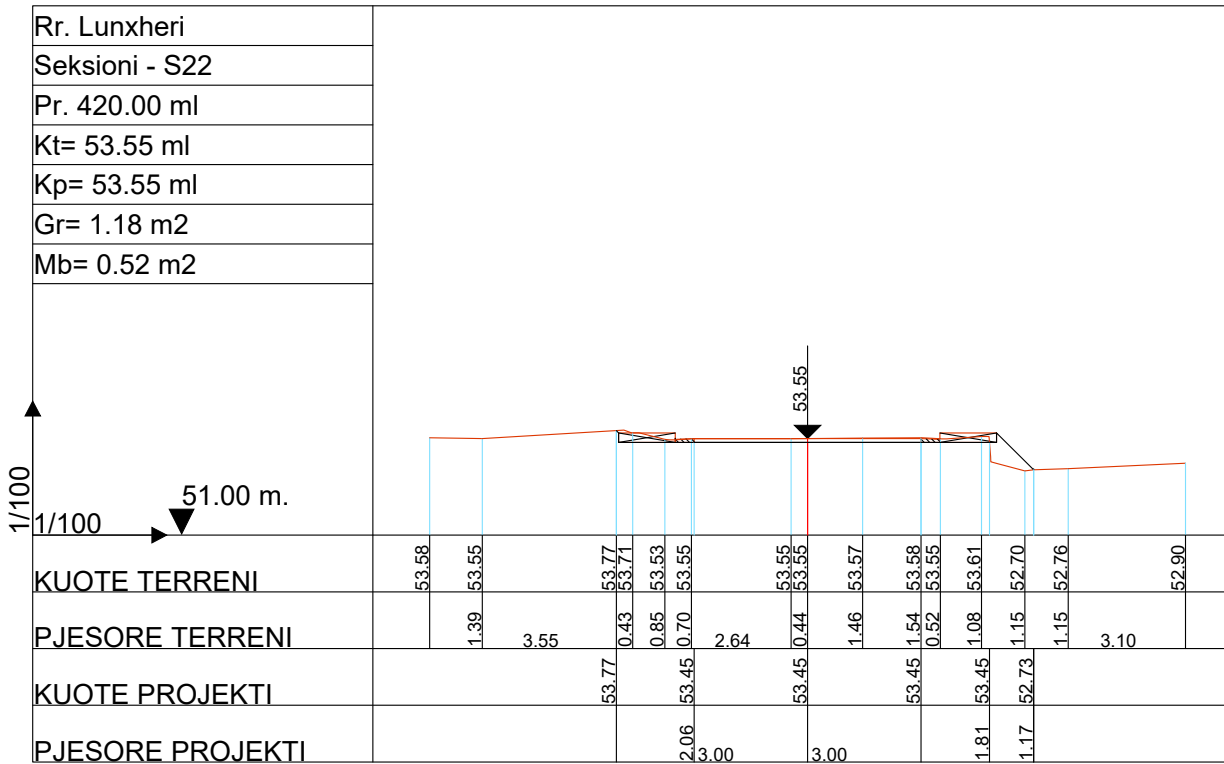
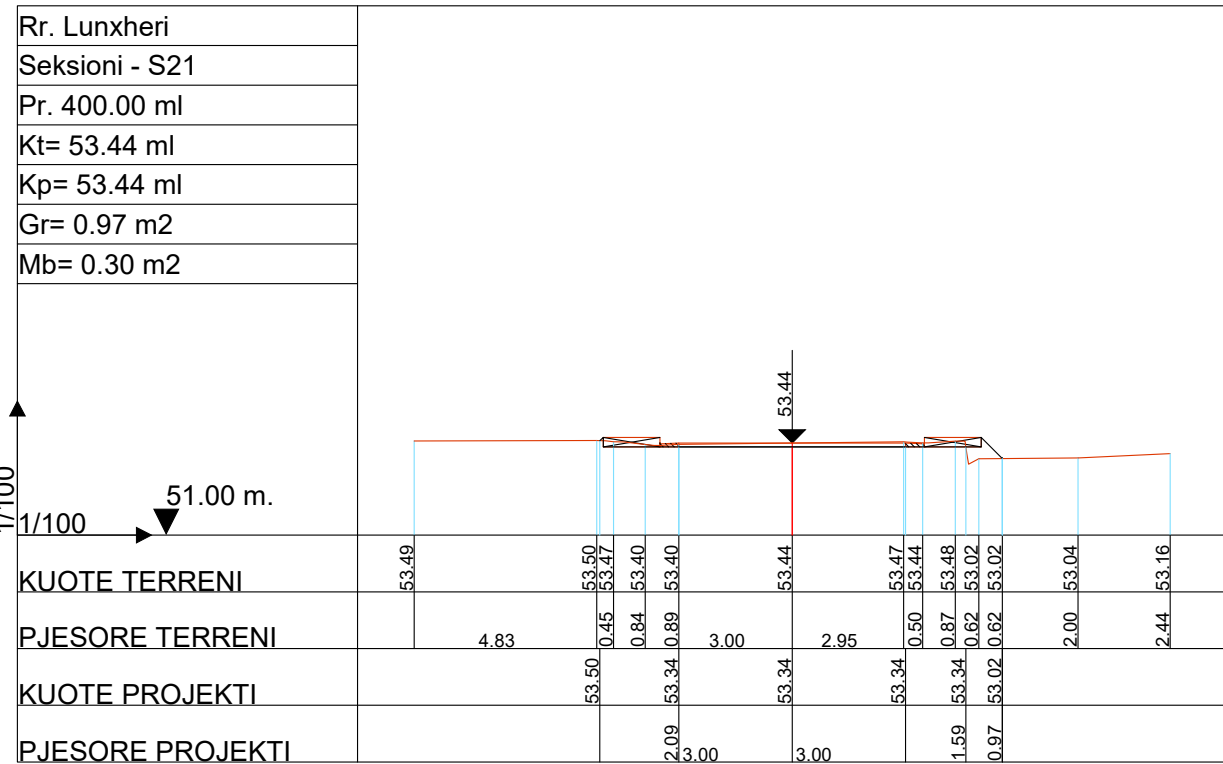

BASHKIA KAMEZ

DREJTORIA E SHERBIMEVE PUBLIKE
DREJTORIA E PROJEKTEVE DHE INVESTIMEVE
DEPARTAMENTI I PROJEKTEVE

Dr. e Projekteve e Investimeve	FLORA MUCA
--------------------------------	------------

STAFI TEKNIK PROJEKTES	Ing.	ARJOLA KURTI
	Ing.	ERBLIN LALA
	Ing.	DENIS PRENCI
	Ing.	RAMADAN HYSA

Titulli i Projektit	Faza e Projektit
RIKONSTRUKSION RRUGA "LUNXHERI", NDERTIM RRUGA PARALEL ME RR "LUNXHERI", PINGUL ME RR "DURRESI", PINGUL ME RR "LURA", RRUGA "KORCE", MUR MBAJTES RRUGA "KOZAR"	PROJEKT ZBATIMI
Emertimi i Fletes	Data e Implementimit :
PROFILET TERTHORE	Shkalla e Vizatimit 1:200
	Fieta Nr. 06

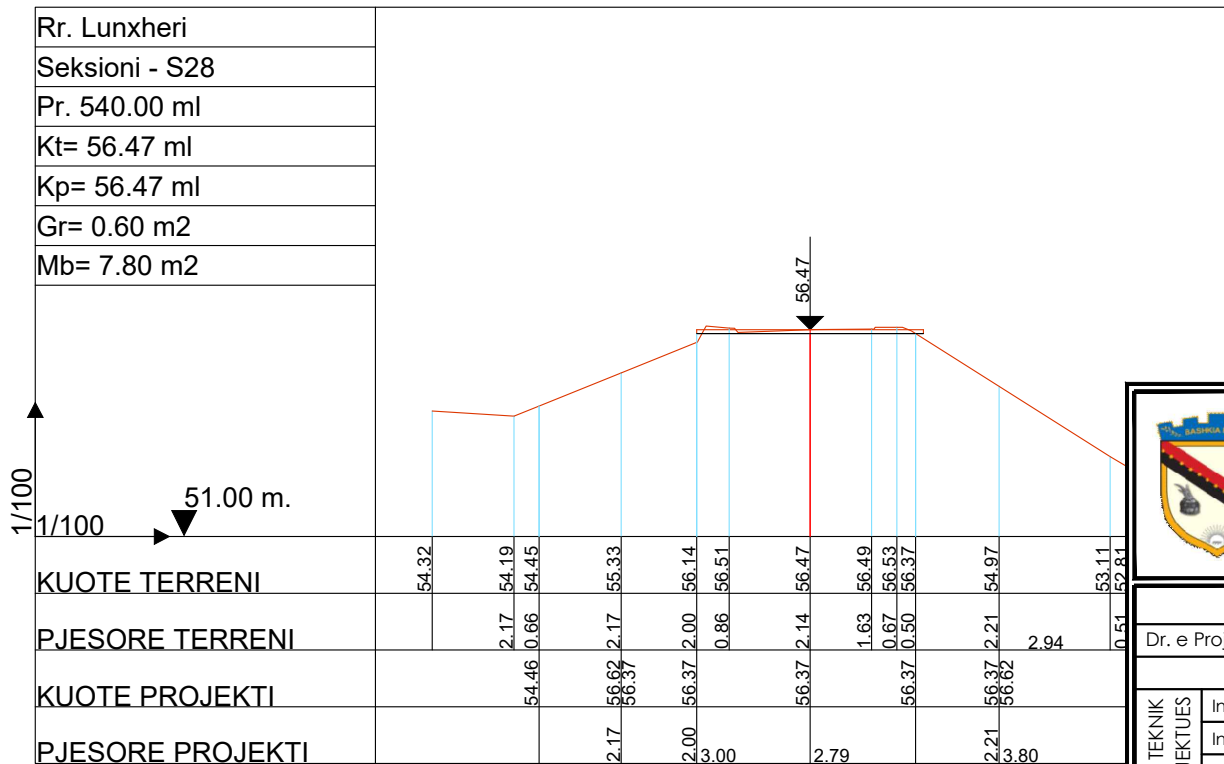
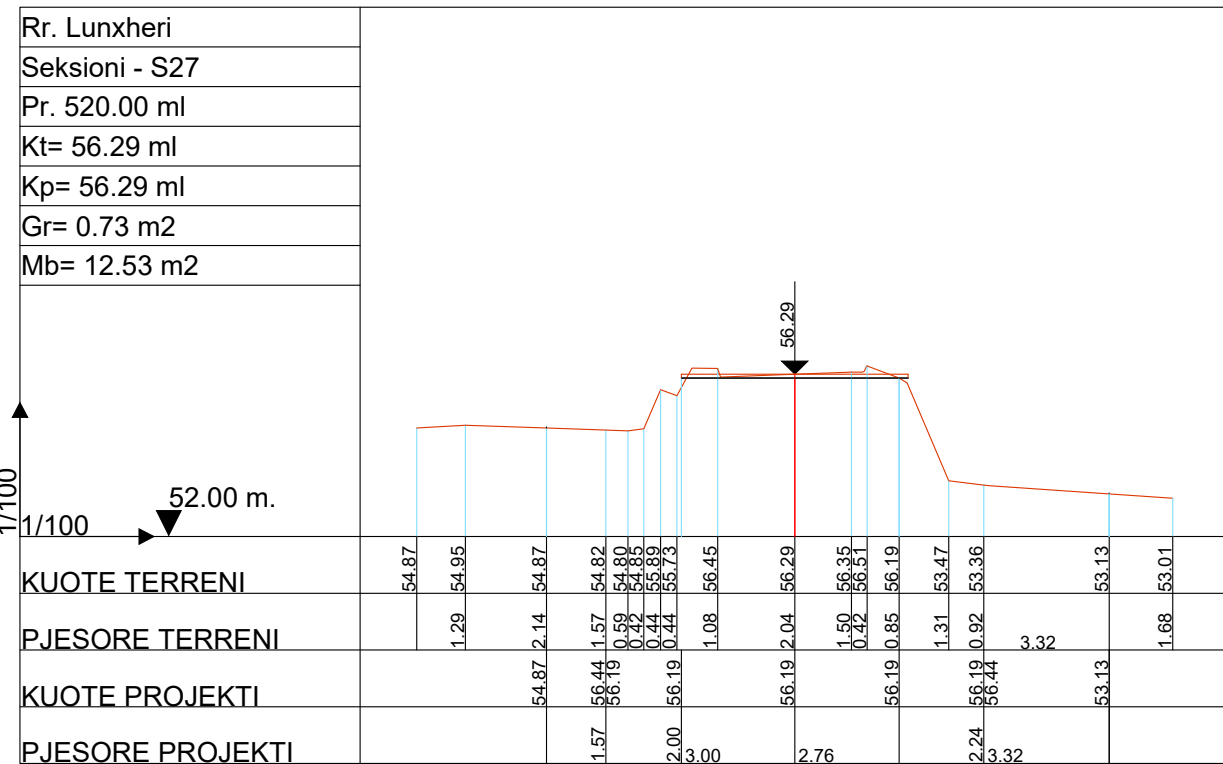
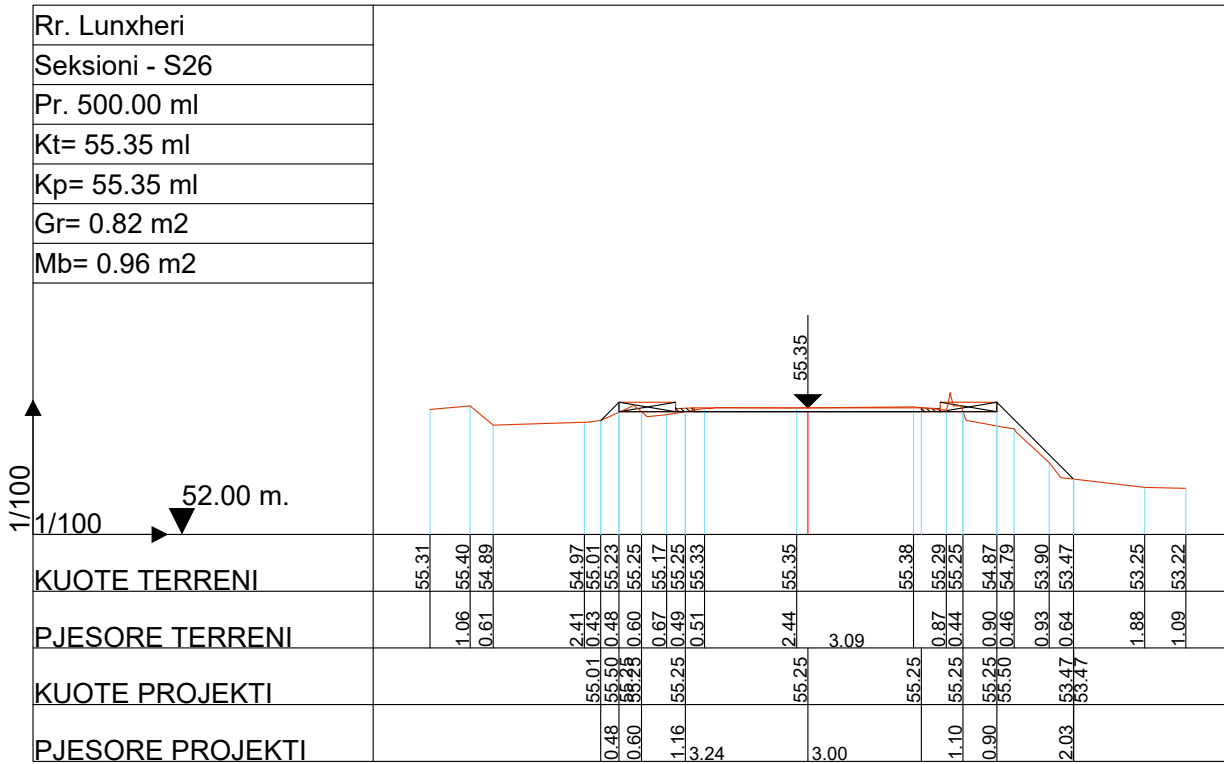
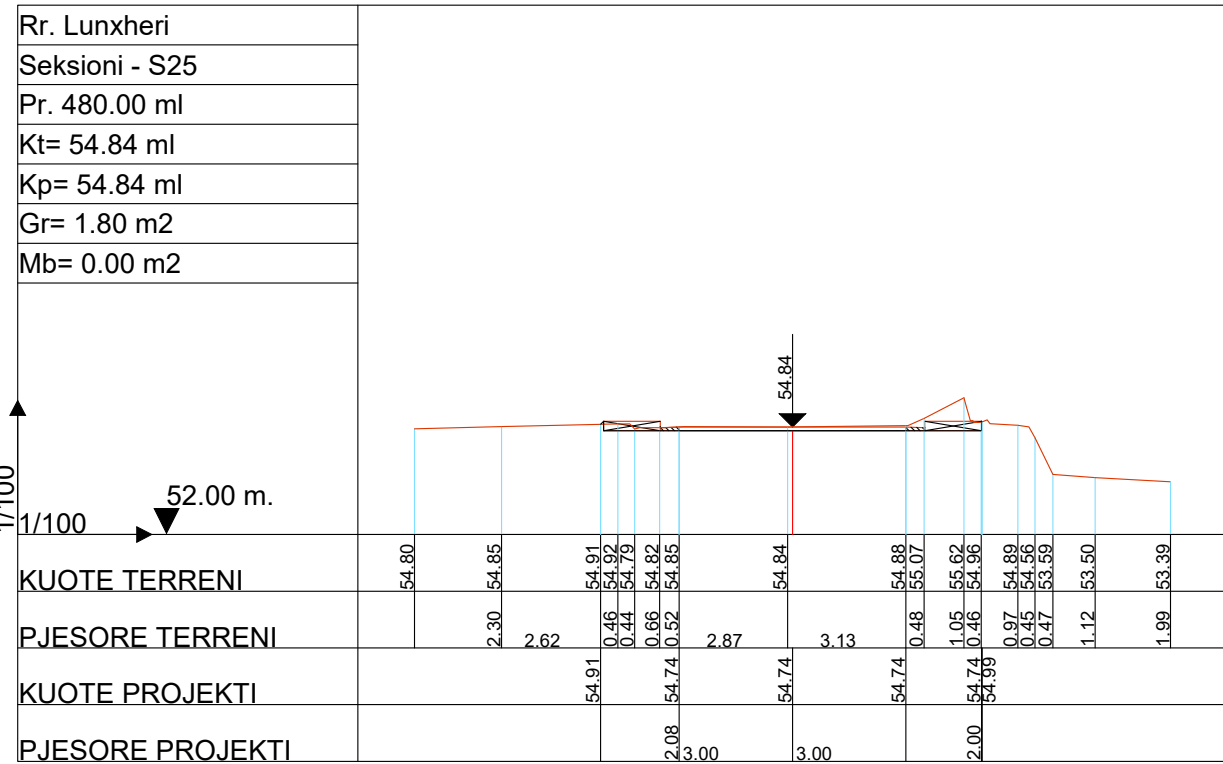

BASHKIA KAMEZ

DREJTORIA E SHERBIMEVE PUBLIKE
DREJTORIA E PROJEKTEVE DHE INVESTIMEVE
DEPARTAMENTI I PROJEKTEVE

Dr. e Projekteve e Investimeve	FLORA MUCA
--------------------------------	------------

STAFI TEKNIK PROJEKTEUES	Ing.	ARJOLA KURTI
	Ing.	ERBLIN LALA
	Ing.	DENIS PRENCI
	Ing.	RAMADAN HYSA

Titulli i Projektit RIKONSTRUKSION RRUGA "LUNXHERI", NDERTIM RRUGA PARALEL ME RR "LUNXHERI", PINGUL ME RR "DURRESI", PINGUL ME RR "LURA", RRUGA "KORCE", MUR MBAJTES RRUGA "KOZAR"	Faza e Projektit PROJEKT ZBATIMI
Emertimi i Fletes PROFILET TERTHORE	Data e Implementimit :
	Shkalla e Vizatimit 1:200
	Fieta Nr. 07

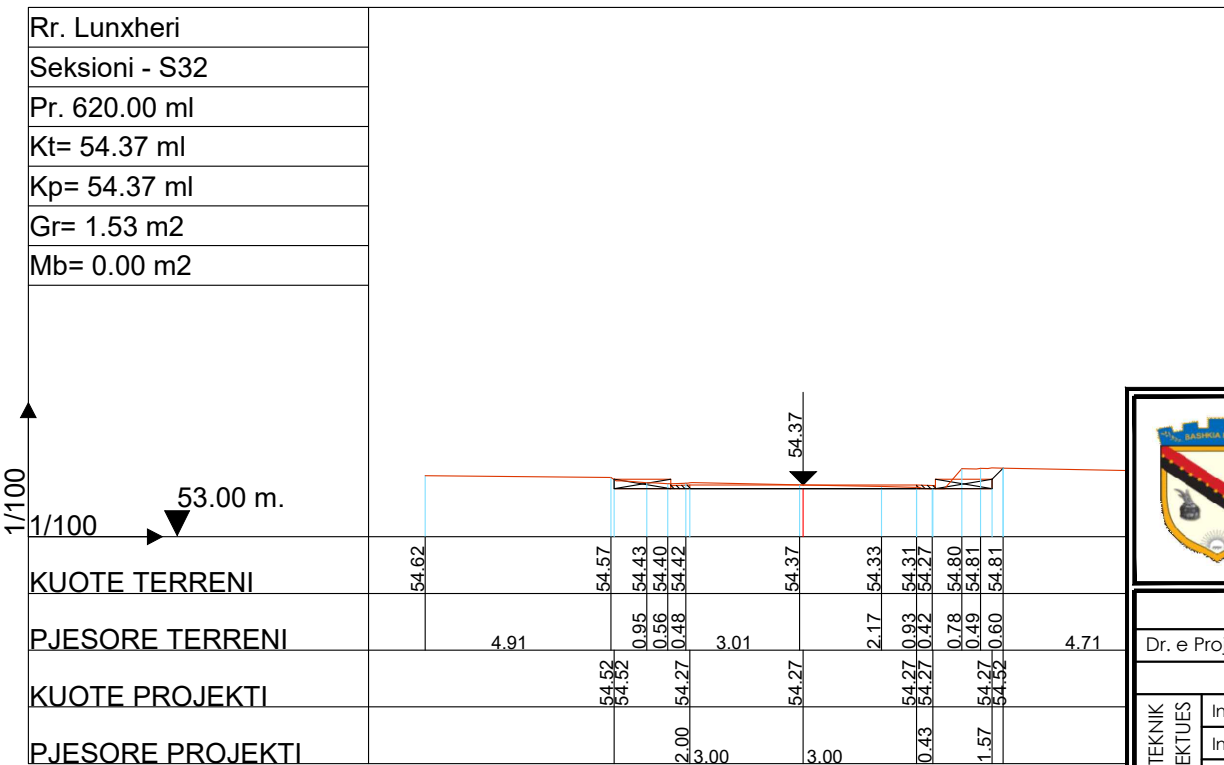
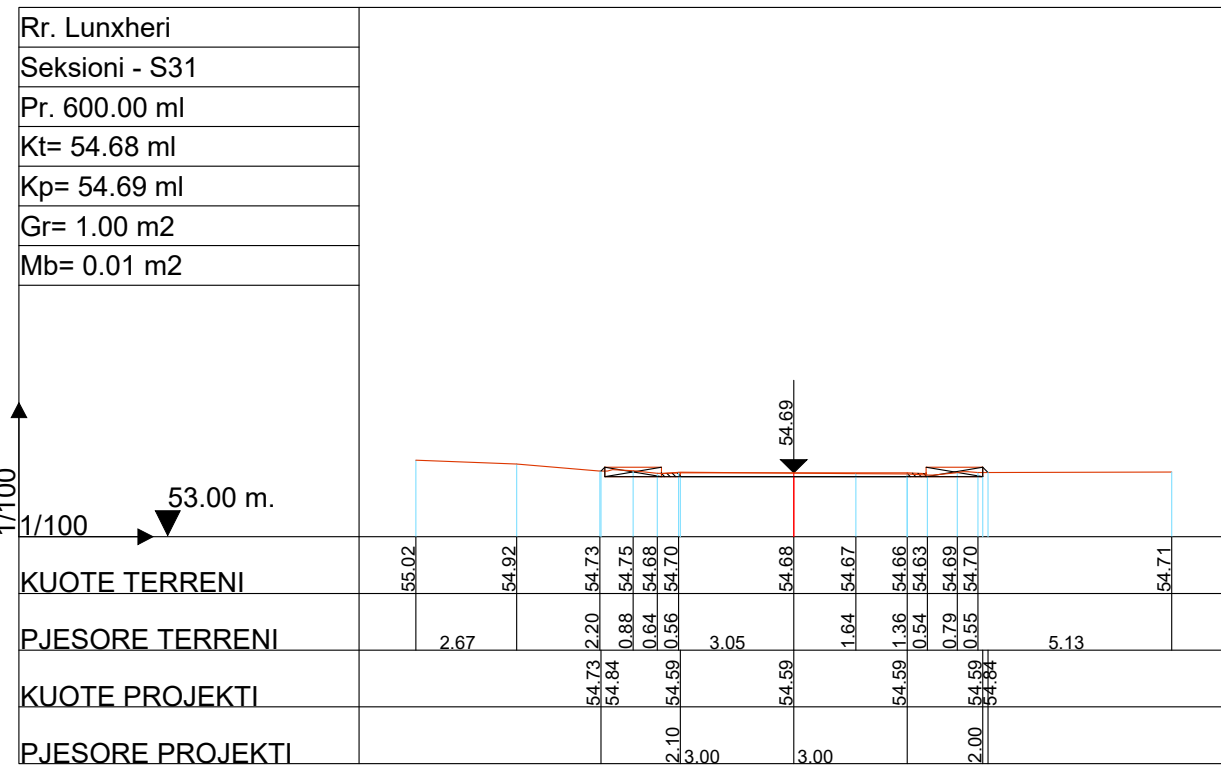
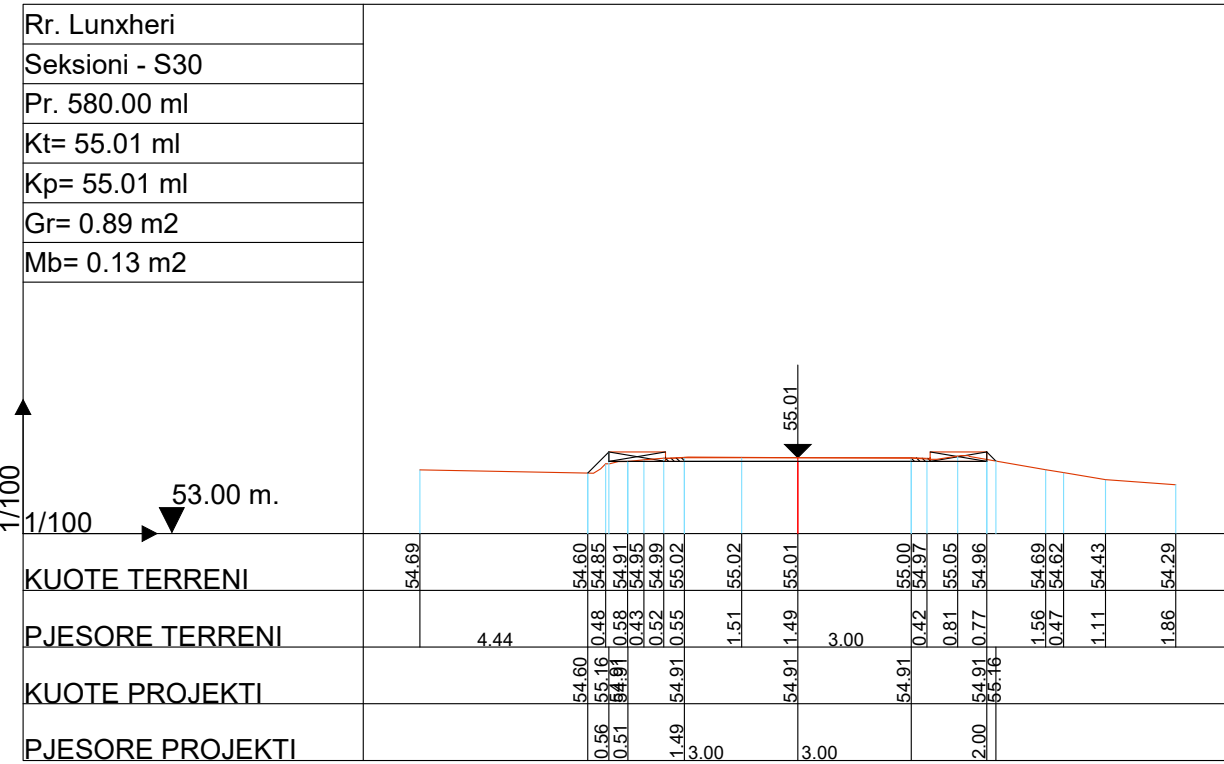
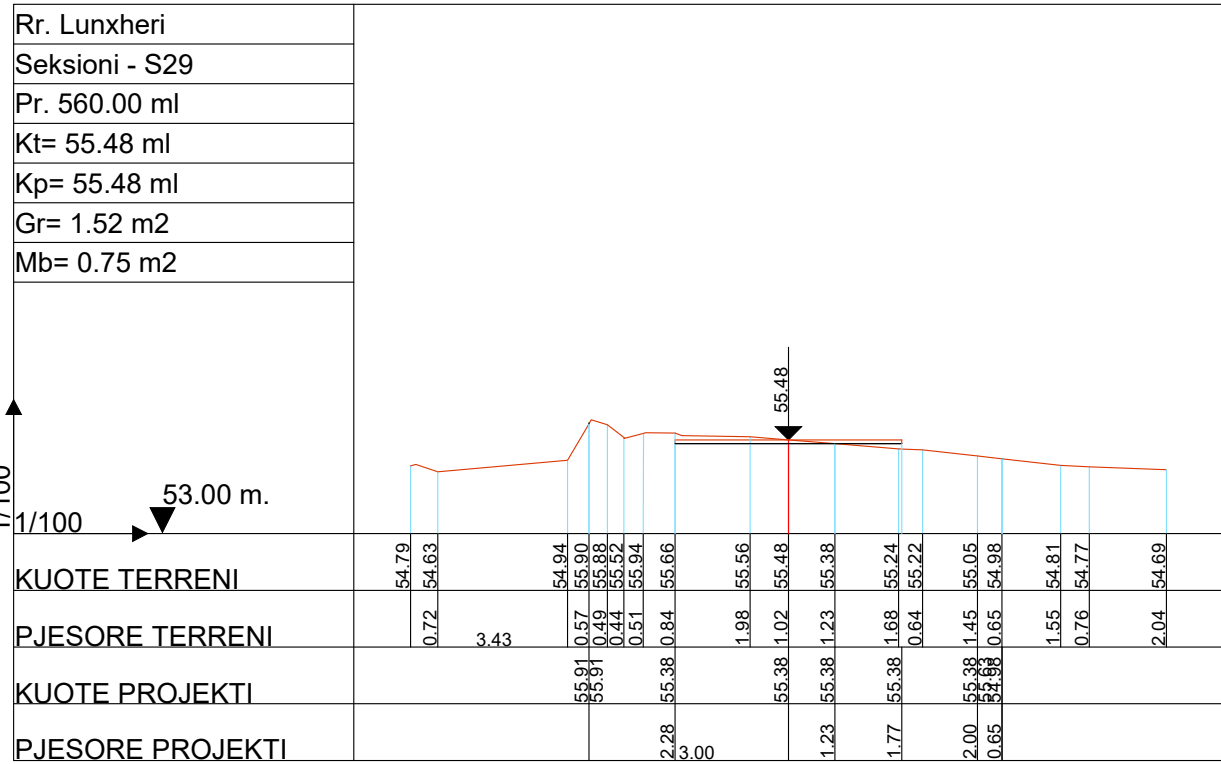



BASHKIA KAMEZ

DREJTORIA E SHERBIMEVE PUBLIKE
DREJTORIA E PROJEKTEVE DHE INVESTIMEVE
DEPARTAMENTI I PROJEKTEVE

Dr. e Projekteve e Investimeve	FLORA MUCA
--------------------------------	------------

STAFI TEKNIK PROJEKTEUES	Ing.	ARJOLA KURTI
	Ing.	ERBLIN LALA
	Ing.	DENIS PRENCI
	Ing.	RAMADAN HYSA

Titulli i Projektit RIKONSTRUKSION RRUGA "LUNXHERI", NDERTIM RRUGA PARALEL ME RR "LUNXHERI", PINGUL ME RR "DURRESI", PINGUL ME RR "LURA", RRUGA "KORCE", MUR MBAJTES RRUGA "KOZAR"	Faza e Projektit PROJEKT ZBATIMI
Emertimi i Fletes PROFILET TERTHORE	Data e Implementimit : Shkalla e Vizatimit 1:200 Fieta Nr. 08

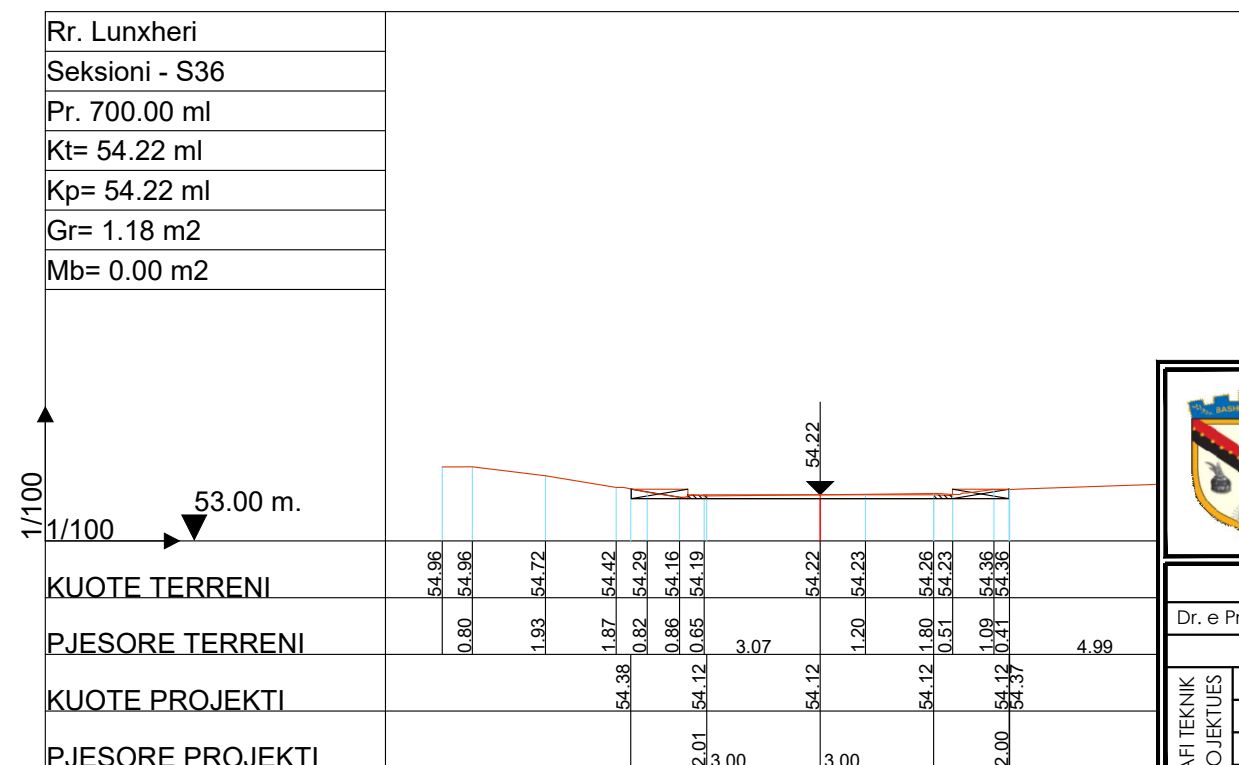
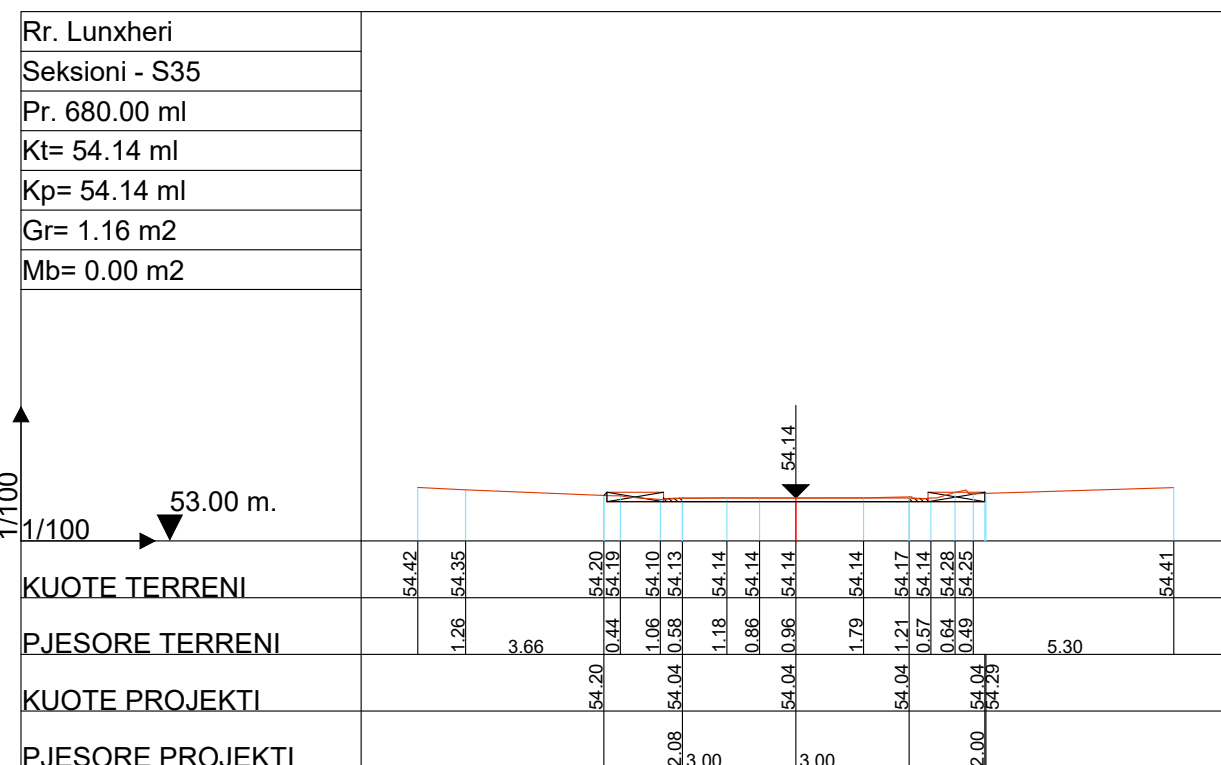
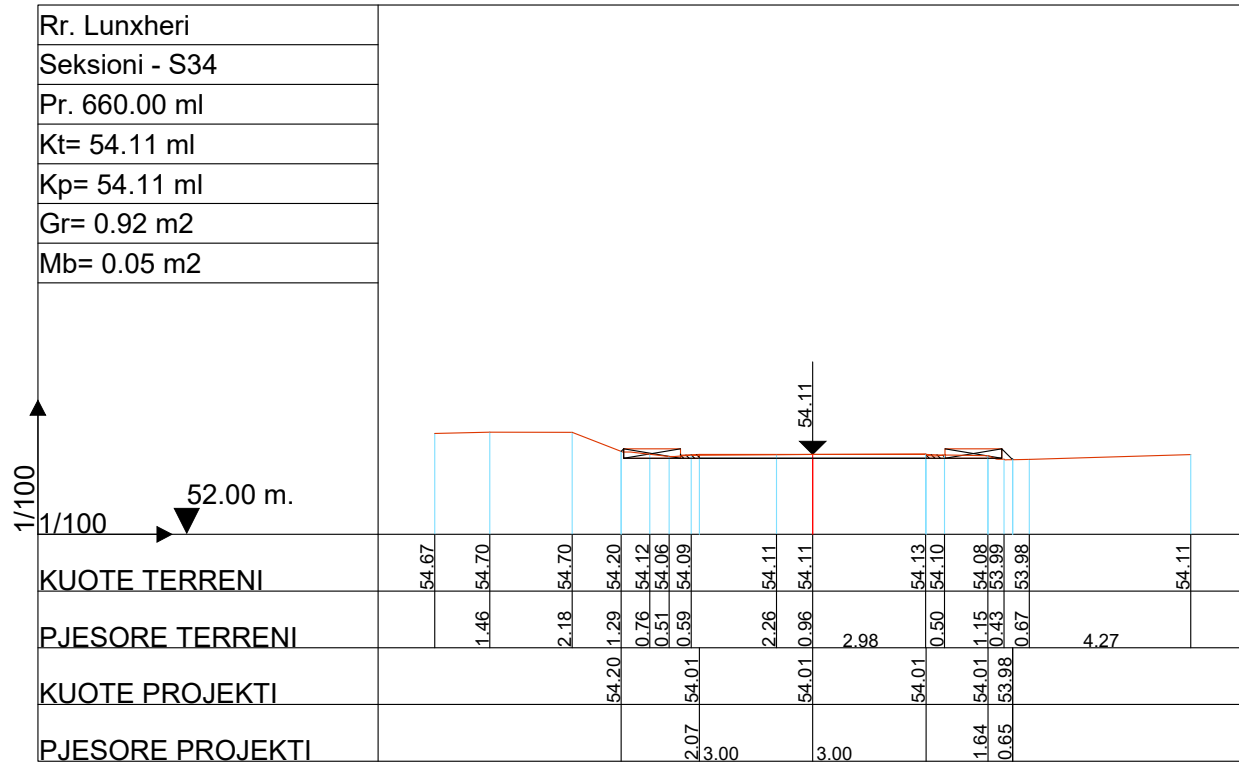
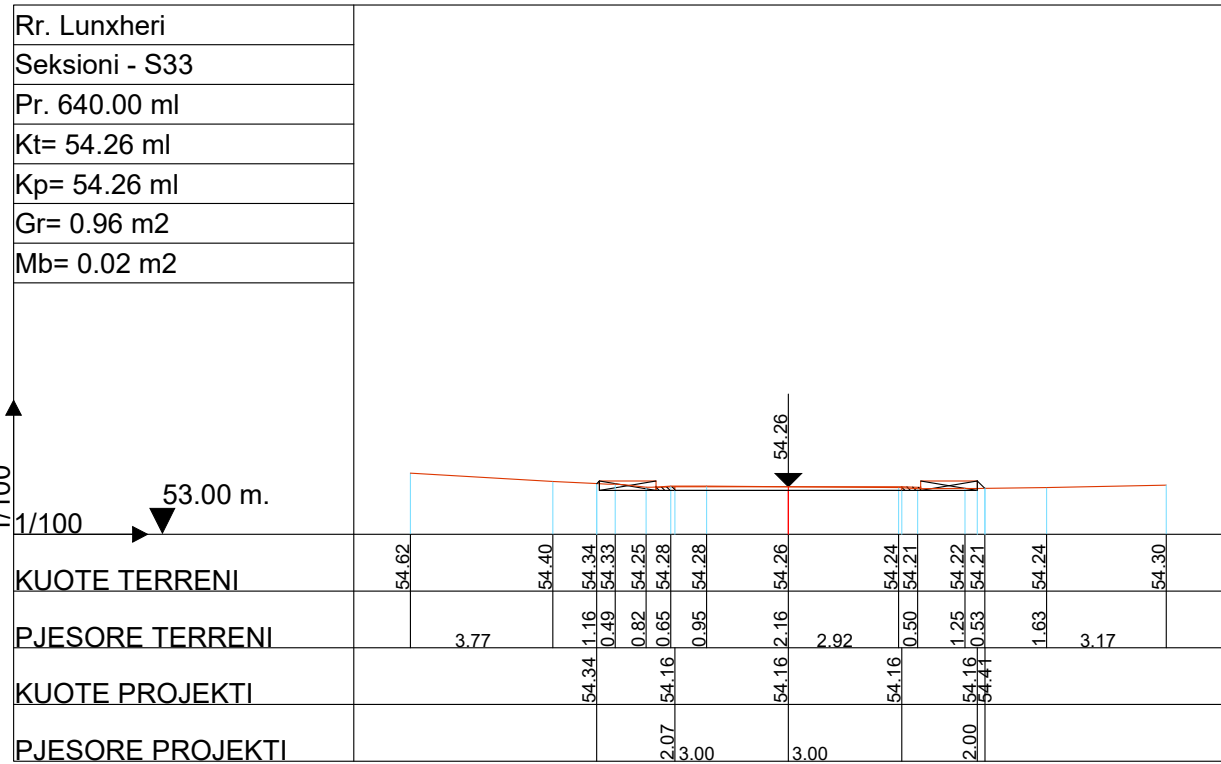



BASHKIA KAMEZ

DREJTORIA E SHERBIMEVE PUBLIKE
DREJTORIA E PROJEKTEVE DHE INVESTIMEVE
DEPARTAMENTI I PROJEKTEVE

Dr. e Projekteve e Investimeve	FLORA MUCA
--------------------------------	------------

STAFI TEKNIK PROJEKTUES	Ing.	ARJOLA KURTI
	Ing.	ERBLIN LALA
	Ing.	DENIS PRENCI
	Ing.	RAMADAN HYSA

Titulli i Projektit RIKONSTRUKSION RRUGA "LUNXHERI", NDERTIM RRUGA PARALEL ME RR "LUNXHERI", PINGUL ME RR "DURRESI", PINGUL ME RR "LURA", RRUGA "KORCE", MUR MBAJTES RRUGA "KOZAR"	Faza e Projektit PROJEKT ZBATIMI
Emerentimi i Fletes PROFILET TERTHORE	Data e Implementimit : Shkalla e Vizatimit 1:200 Fieta Nr. 09

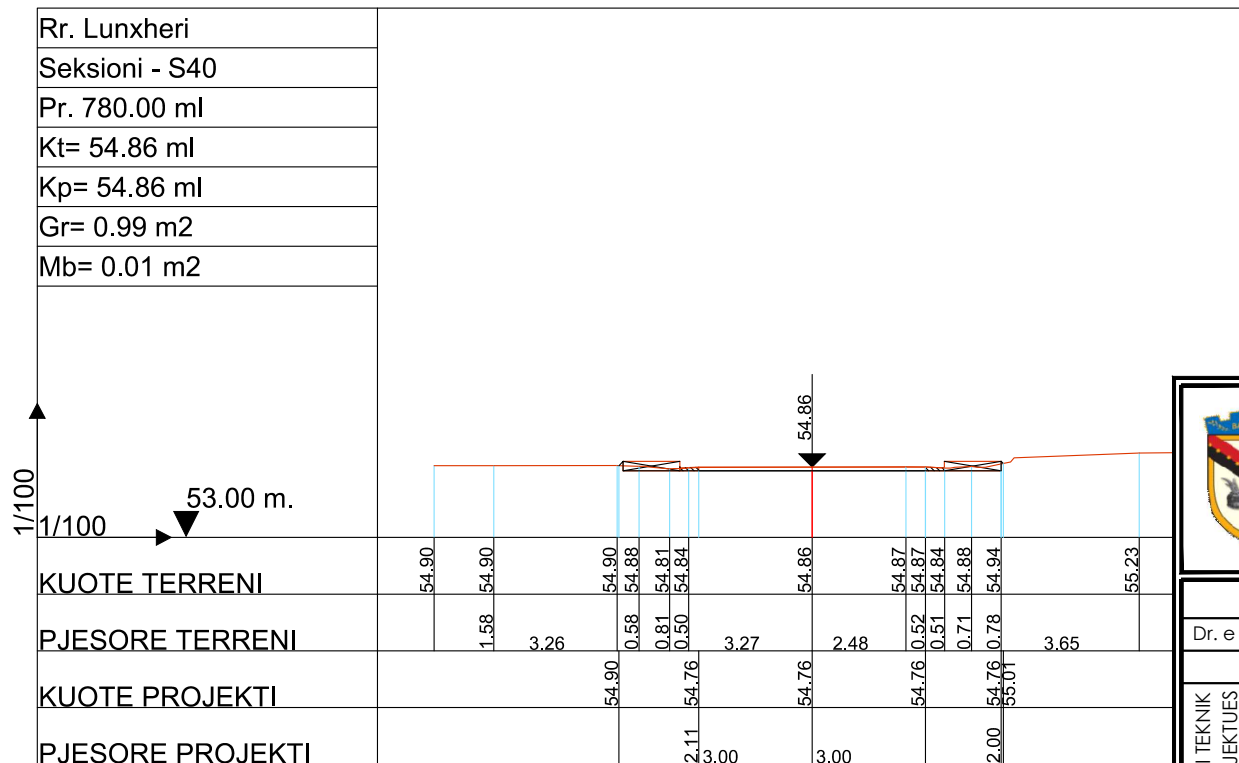
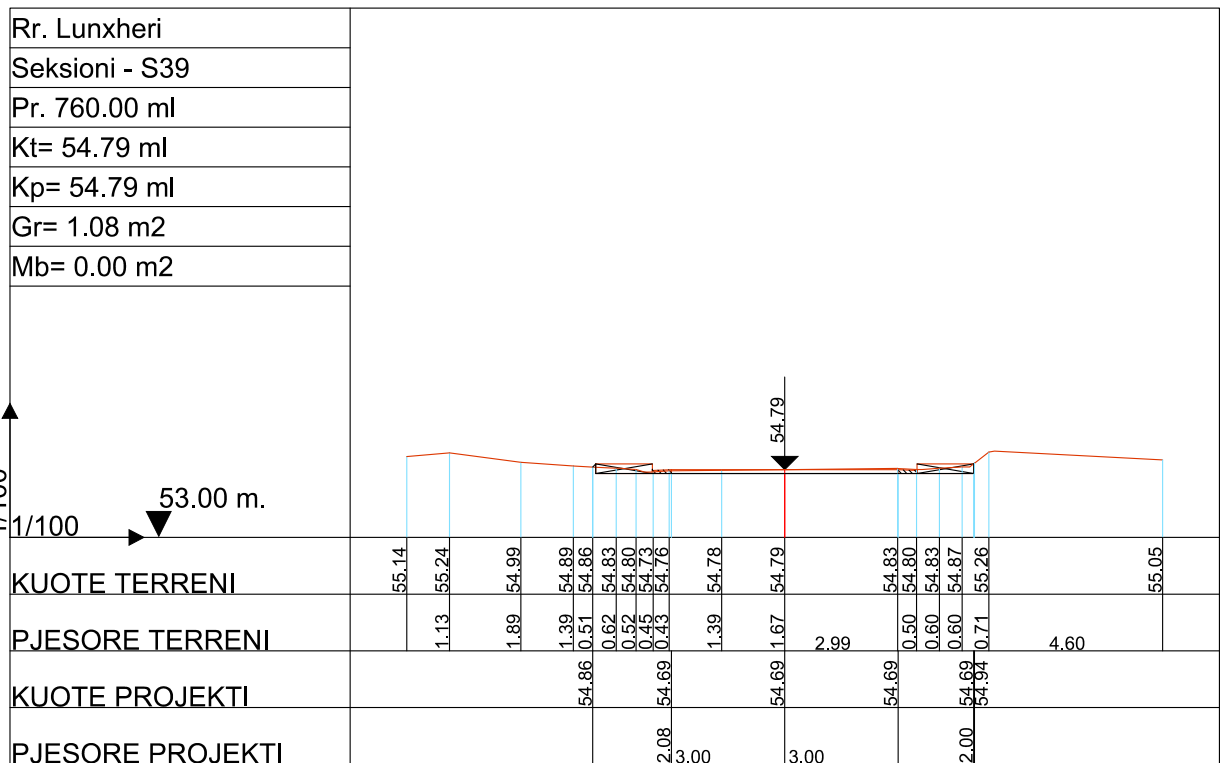
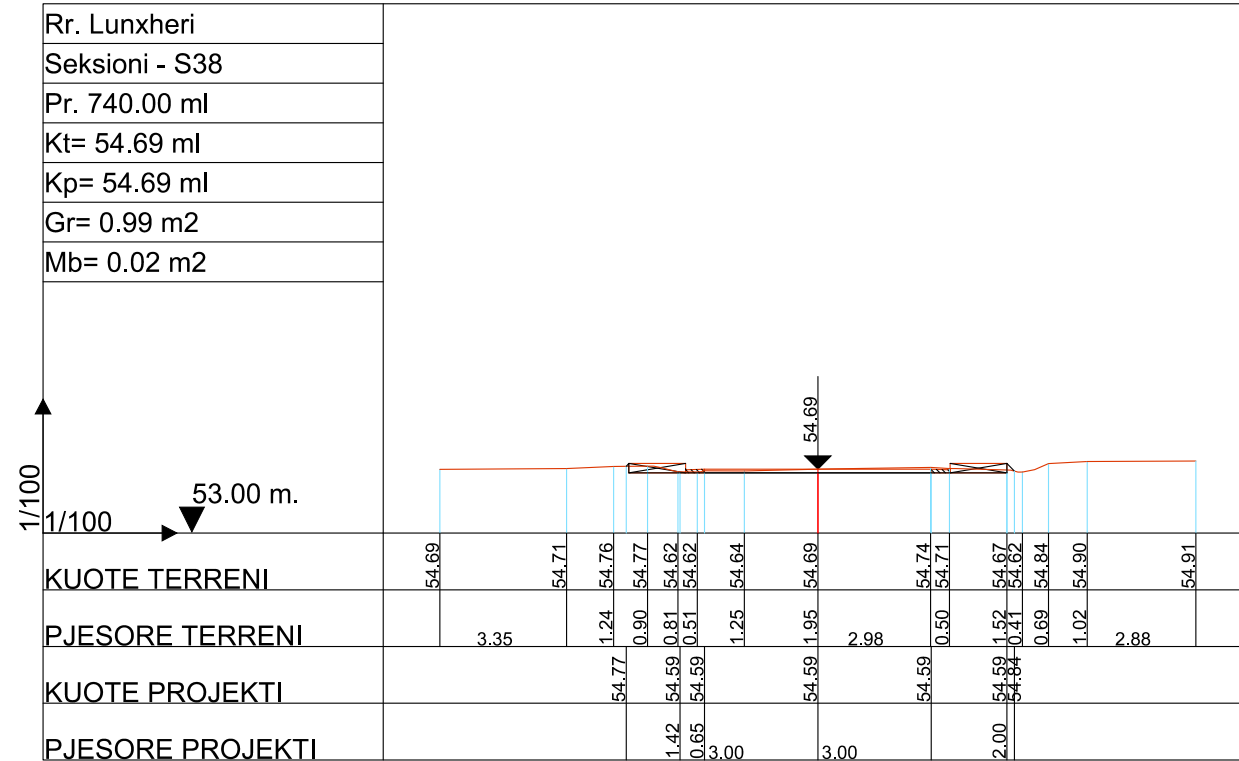
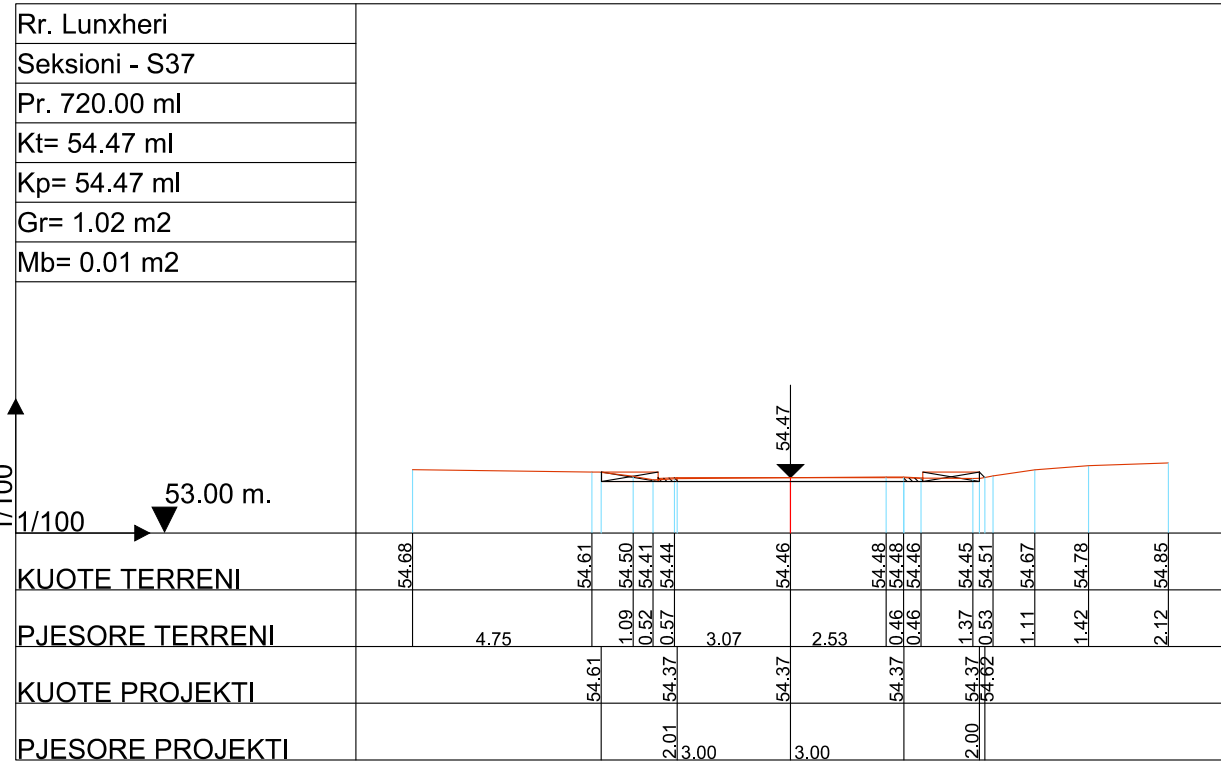

BASHKIA KAMEZ

DREJTORIA E SHERBIMEVE PUBLIKE
DREJTORIA E PROJEKTEVE DHE INVESTIMEVE
DEPARTAMENTI I PROJEKTEVE

Dr. e Projekteve e Investimeve	FLORA MUCA
--------------------------------	------------

STAFI TEKNIK PROJEKTES	Ing.	ARJOLA KURTI
	Ing.	ERBLIN LALA
	Ing.	DENIS PRENCI
	Ing.	RAMADAN HYSA

Titulli i Projektit RIKONSTRUKSION RRUGA "LUNXHERI", NDERTIM RRUGA PARALEL ME RR "LUNXHERI", PINGUL ME RR "DURRESI", PINGUL ME RR "LURA", RRUGA "KORCE", MUR MBAJTES RRUGA "KOZAR"	Faza e Projektit PROJEKT ZBATIMI
Emertimi i Fletes PROFILET TERTHORE	Data e Implementimit :
	Shkalla e Vizatimit 1:200
	Fieta Nr. 10

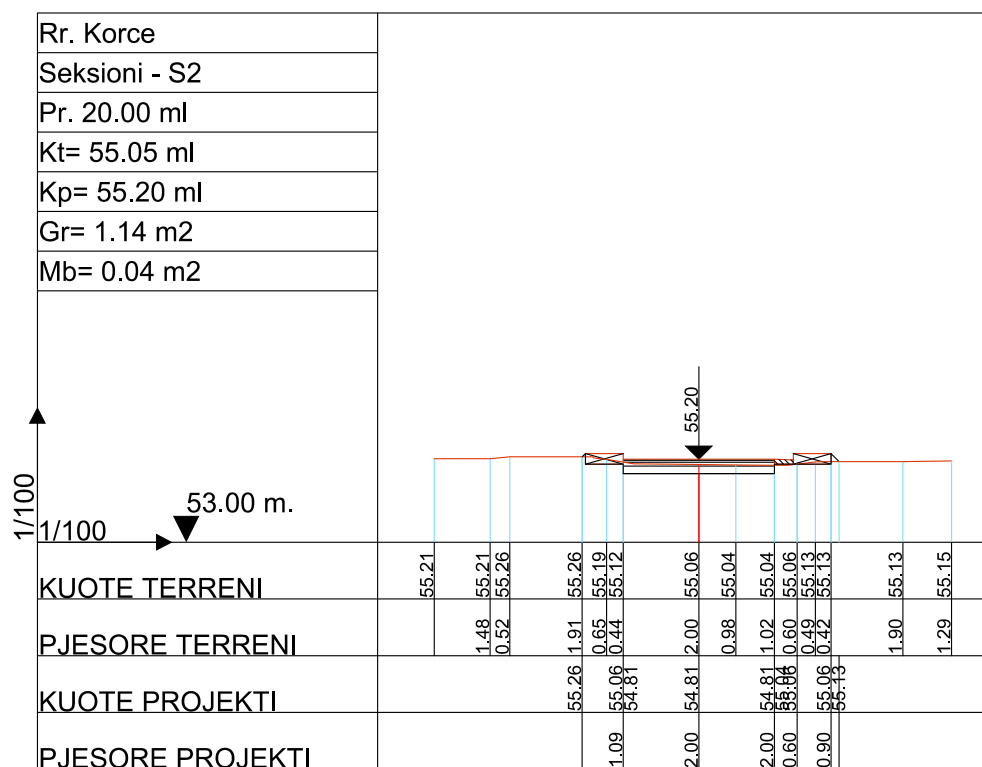
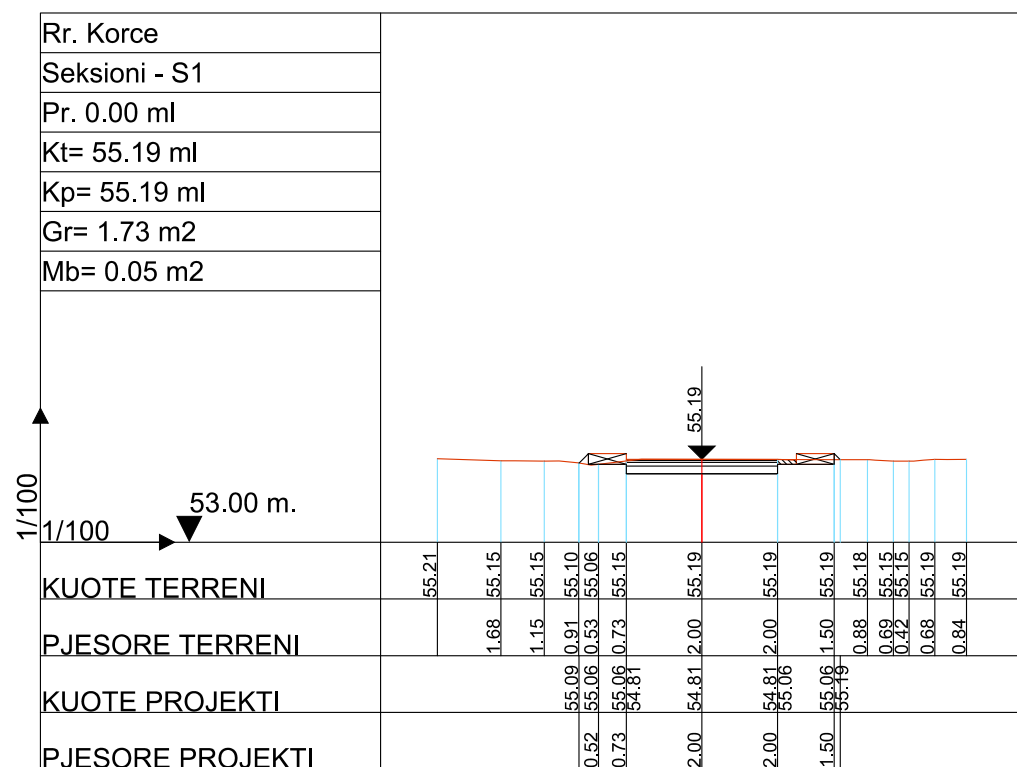
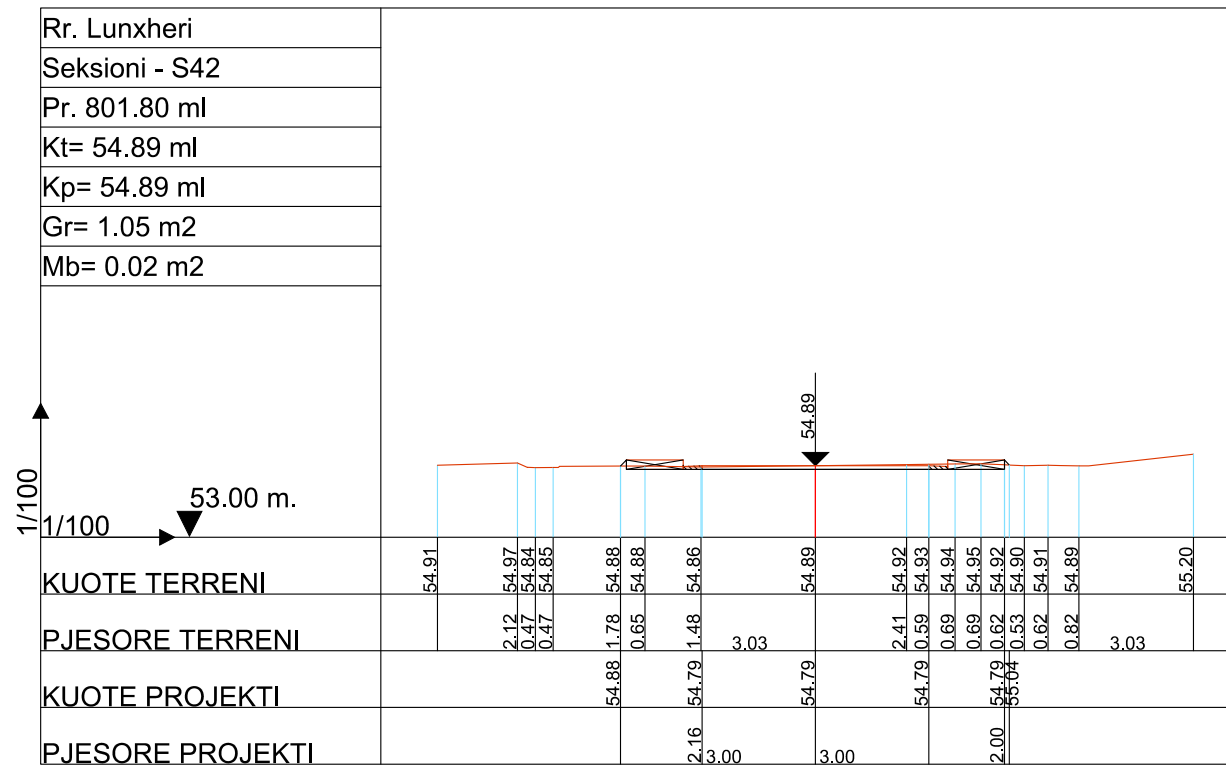
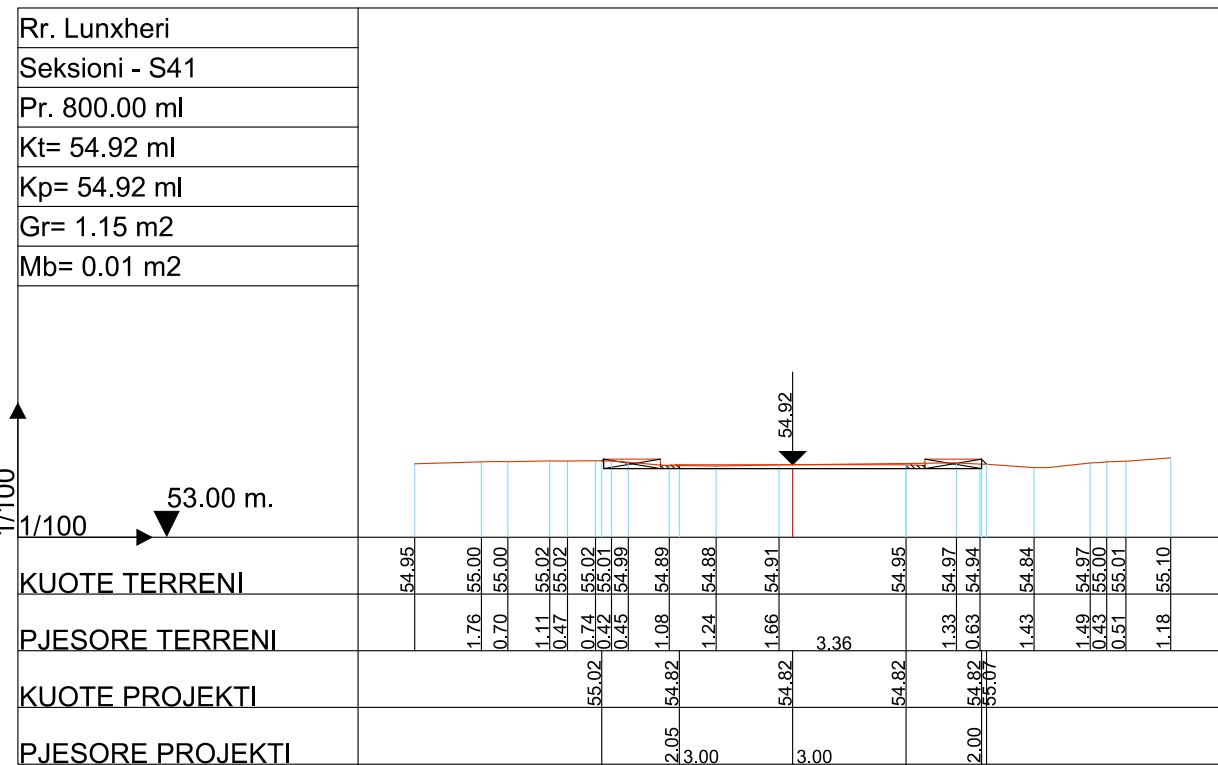



BASHKIA KAMEZ

DREJTORIA E SHERBIMEVE PUBLIKE
DREJTORIA E PROJEKTEVE DHE INVESTIMEVE
DEPARTAMENTI I PROJEKTEVE

Dr. e Projekteve e Investimeve	FLORA MUCA
STAFI TEKNIK PROJEKTES	Ing. ARJOLA KURTI
	Ing. ERBLIN LALA
	Ing. DENIS PRENCI
	Ing. RAMADAN HYSA

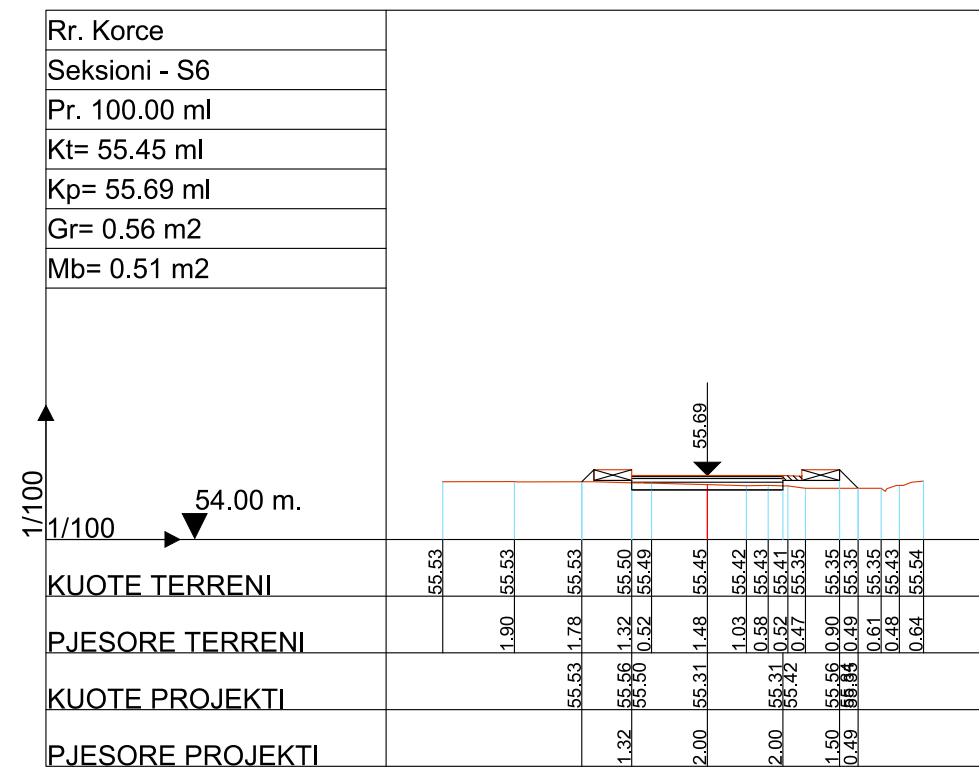
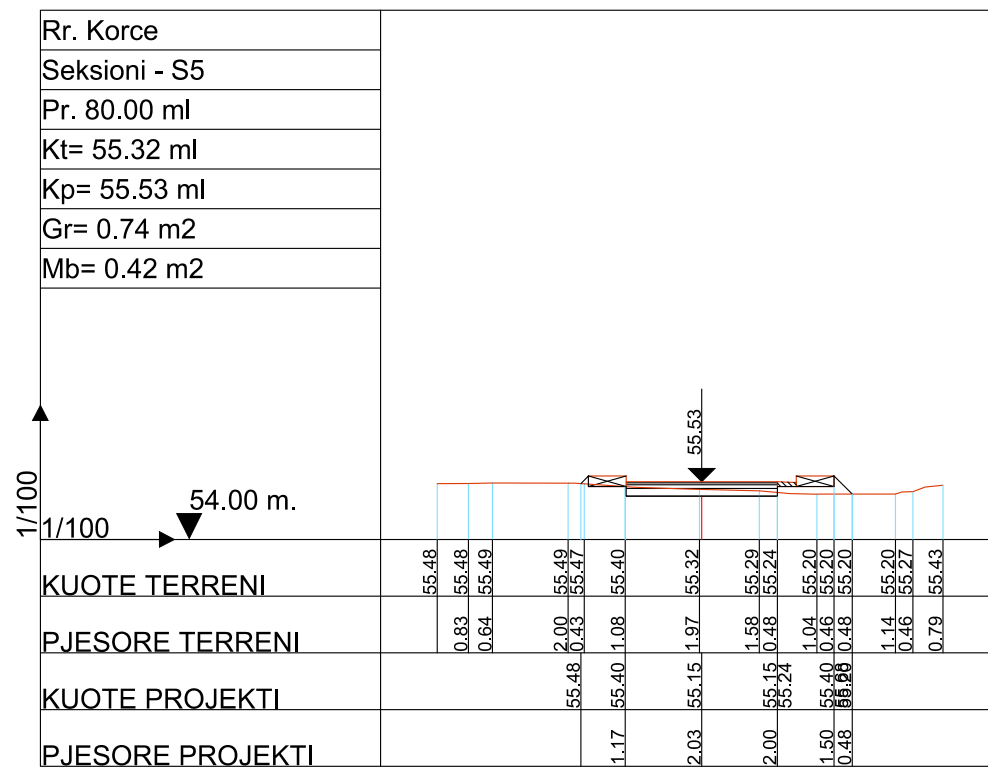
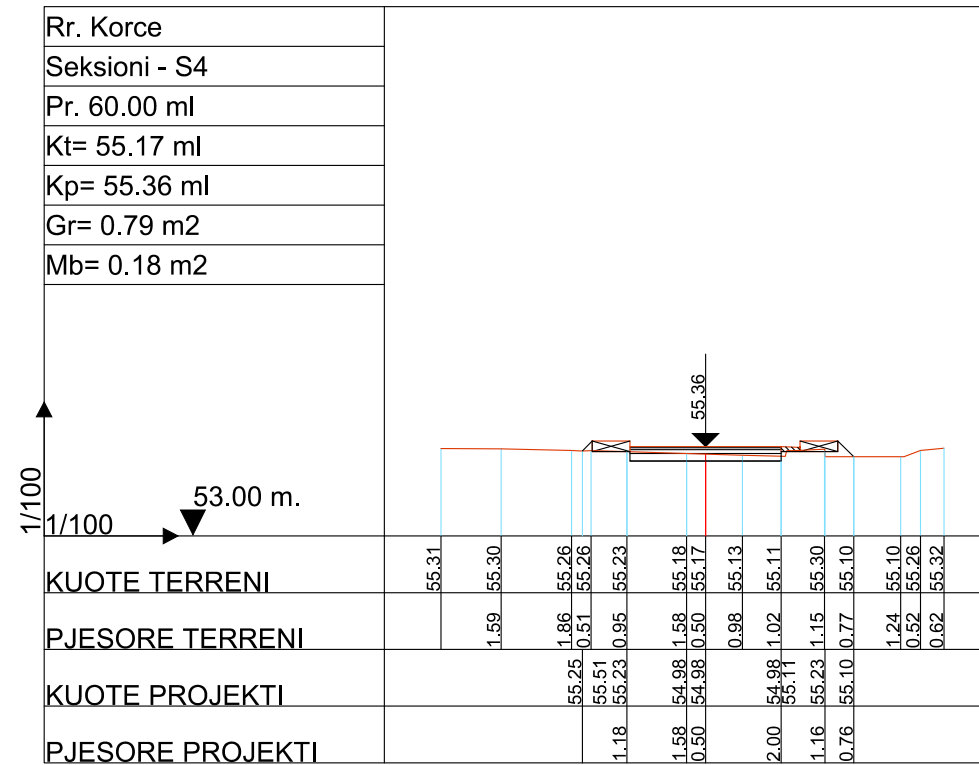
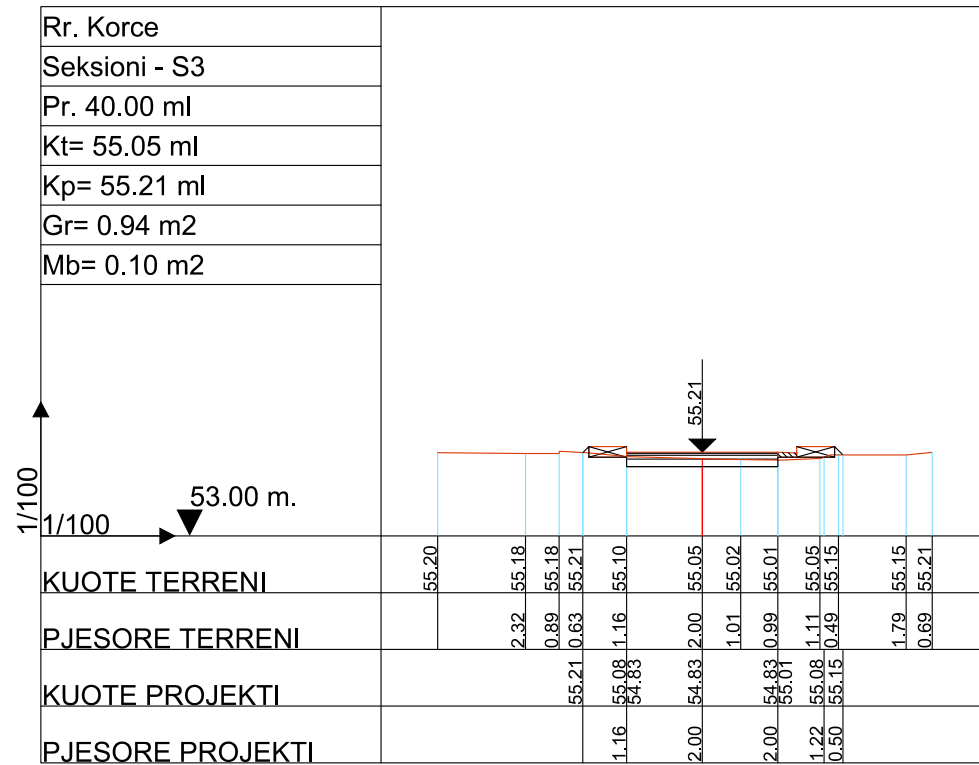
Titulli i Projektit	RIKONSTRUKSION RRUGA "LUNXHERI", NDERTIM RRUGA PARALEL ME RR "LUNXHERI", PINGUL ME RR "DURRESI", PINGUL ME RR "LURA", RRUGA "KORÇE", MUR MBAJTES RRUGA "KOZAR"
Faza e Projektit	PROJEKT ZBATIMI
Data e Implementimit	
Shkalla e Vizatimit	1:200
Emertimi i Fletes	PROFLET TERTHORE
Fieta Nr.	11



BASHKIA KAMEZ

DREJTORIA E SHERBIMEVE PUBLIKE
DREJTORIA E PROJEKTEVE DHE INVESTIMEVE
DEPARTAMENTI I PROJEKTEVE

Dr. e Projekteve e Investimeve	FLORA MUCA
--------------------------------	------------

STAFI TEKNIK PROJEKTEUES	Ing.	ARJOLA KURTI
	Ing.	ERBLIN LALA
	Ing.	DENIS PRENCI
	Ing.	RAMADAN HYSA

Titulli i Projektit RIKONSTRUKSION RRUGA "LUNXHERI", NDERTIM RRUGA PARALEL ME RR "LUNXHERI", PINGUL ME RR "DURRESI", PINGUL ME RR "LURA", RRUGA "KORCE", MUR MBAJTES RRUGA "KOZAR"	Faza e Projektit PROJEKT ZBATIMI
Emertimi i Fletes PROFILET TERTHORE	Data e Implementimit : Shkalla e Vizatimit 1:200 Fieta Nr. 12

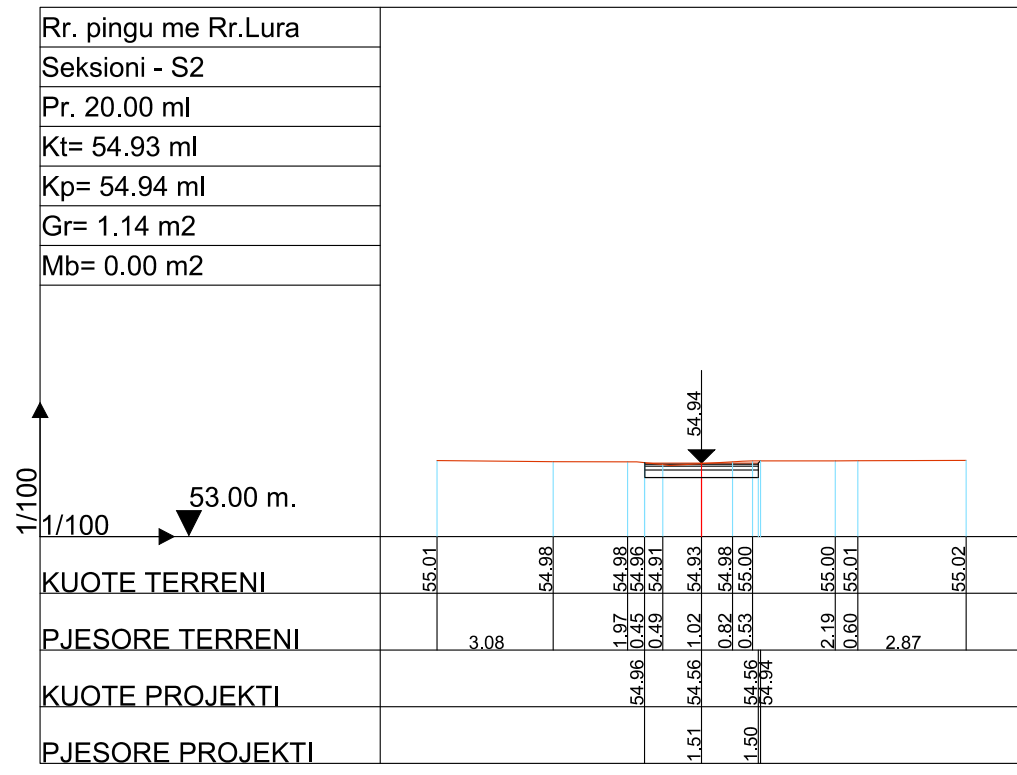
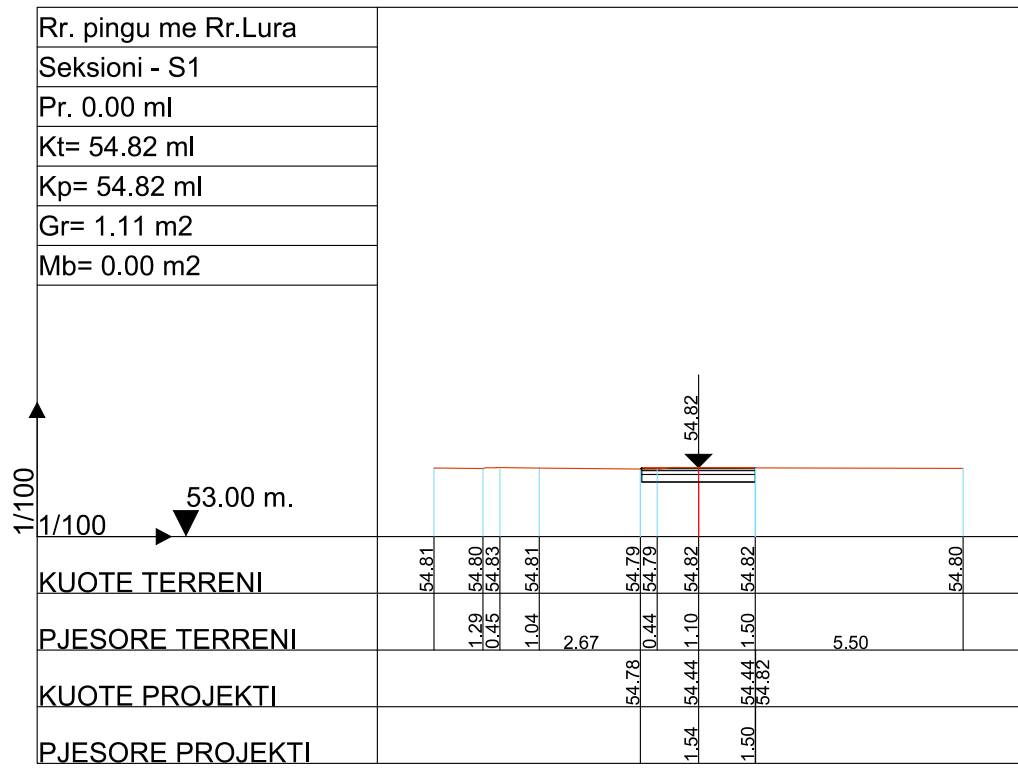
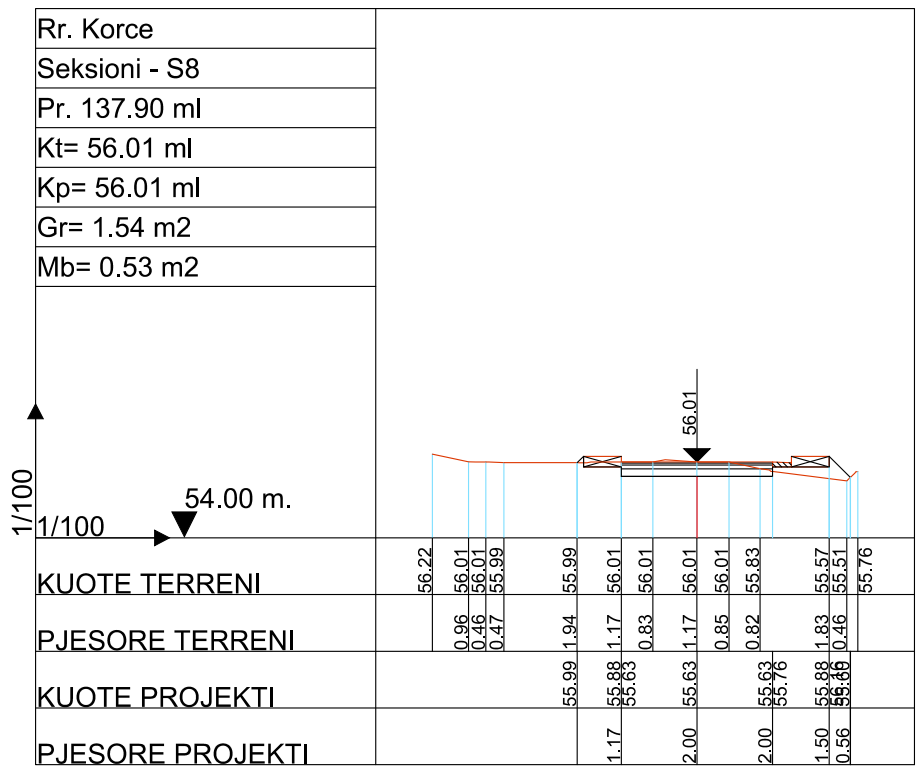
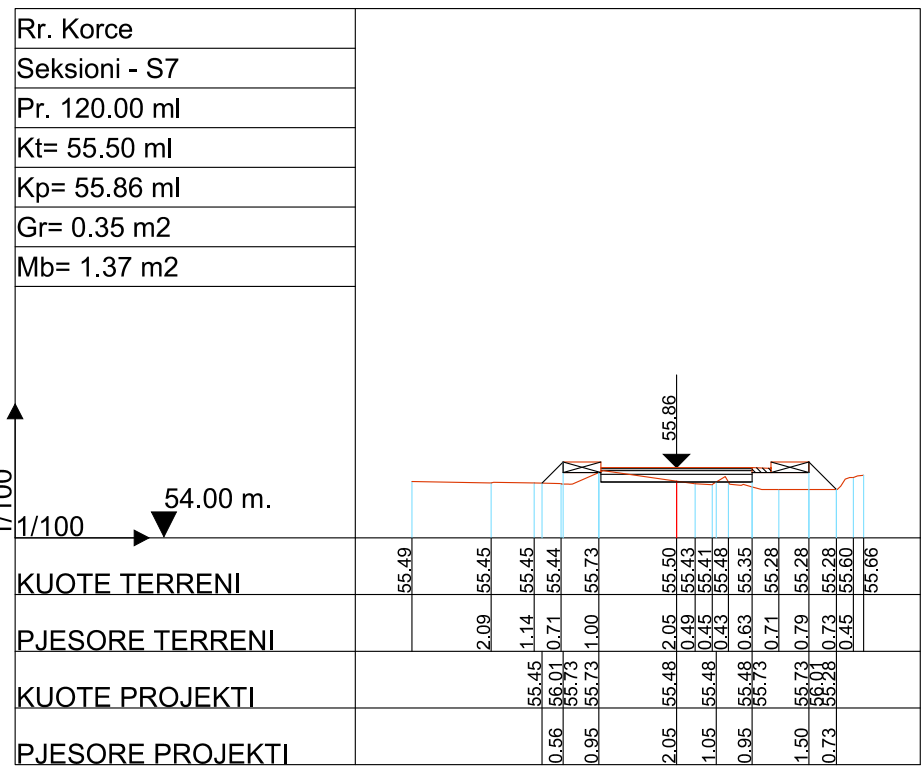



BASHKIA KAMEZ

DREJTORIA E SHERBIMEVE PUBLIKE
DREJTORIA E PROJEKTEVE DHE INVESTIMEVE
DEPARTAMENTI I PROJEKTEVE

Dr. e Projekteve e Investimeve		FLORA MUCA
--------------------------------	--	------------

STAFI TEKNIK PROJEKTES	Ing.	ARJOLA KURTI
	Ing.	ERBLIN LALA
	Ing.	DENIS PRENCI
	Ing.	RAMADAN HYSA

Titulli i Projektit		Faza e Projektit
RIKONSTRUKSION RRUGA "LUNXHERI", NDERTIM RRUGA PARALEL ME RR "LUNXHERI", PINGUL ME RR "DURRESI", PINGUL ME RR "LURA", RRUGA "KORCE", MUR MBAJTES RRUGA "KOZAR"		PROJEKT ZBATIMI
Emertimi i Fletes		Data e Implementimit :
PROFILET TERTHORE		Shkalla e Vizatimit
		1:200
		Fieta Nr.
		13

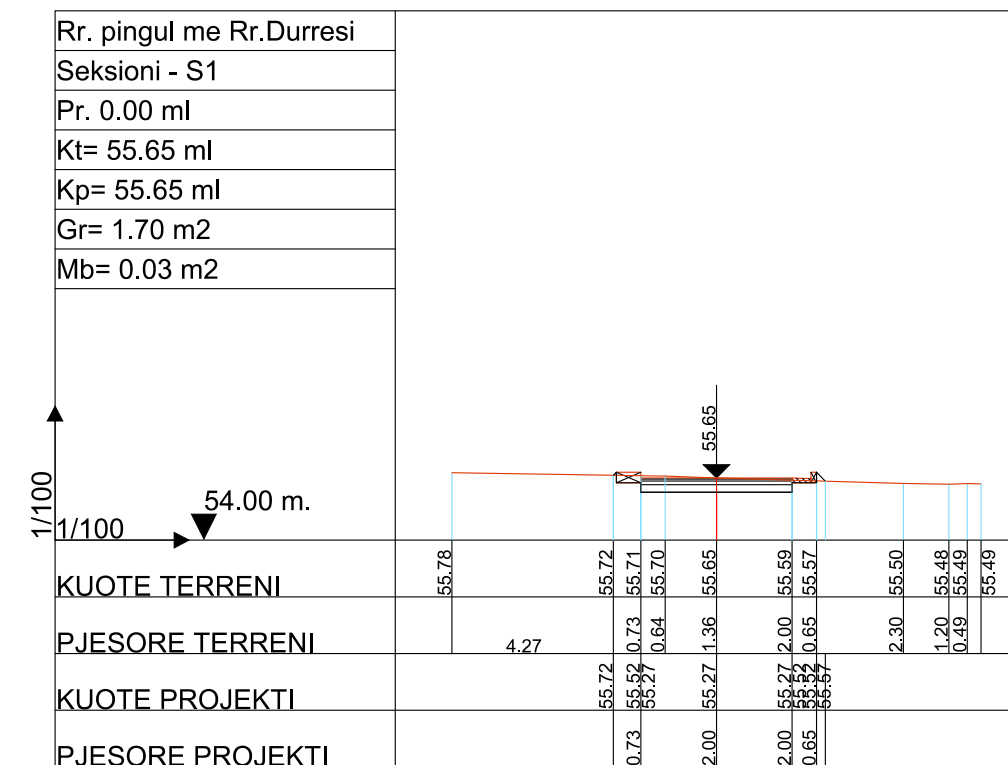
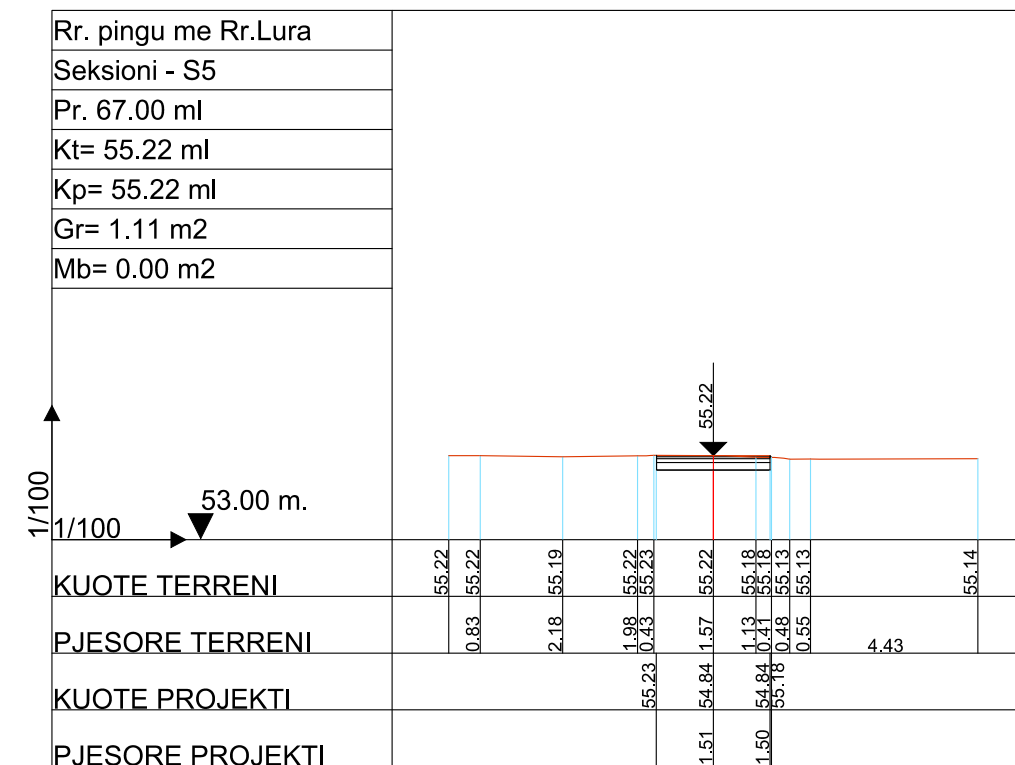
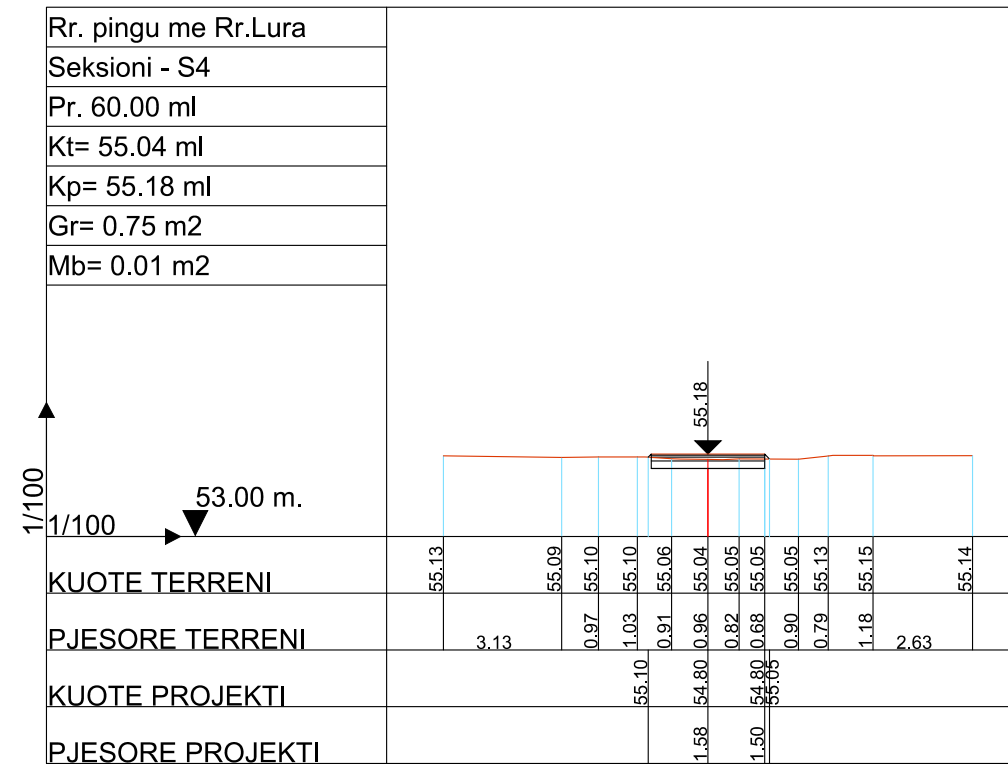
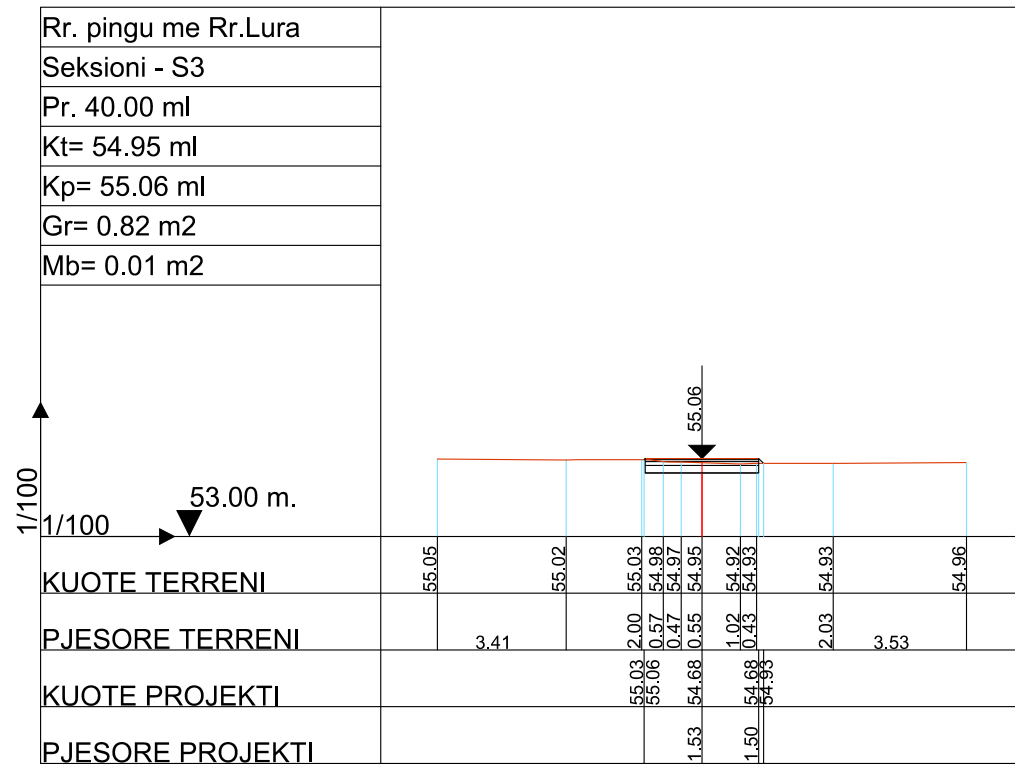

 BASHKIA KAMEZ DREJTORIA E SHERBIMEVE PUBLIKE DREJTORIA E PROJEKTEVE DHE INVESTIMEVE DEPARTAMENTI I PROJEKTEVE		
	Dr. e Projekteve e Investimeve	FLORA MUCA
STAFI TEKNIK PROJEKTES	Ing.	ARJOLA KURTI
	Ing.	ERBLIN LALA
	Ing.	DENIS PRENCI
	Ing.	RAMADAN HYSA
Titulli i Projektit		Faza e Projektit
RIKONSTRUKSION RRUGA "LUNXHERI", NDERTIM RRUGA PARALEL ME RR "LUNXHERI", PINGUL ME RR "DURRESI", PINGUL ME RR "LURA", RRUGA "KORCE", MUR MBAJTES RRUGA "KOZAR"		PROJEKT ZBATIMI
Emertimi i Fletes		Data e Implementimit :
PROFILET TERTHORE		Shkalla e Vizatimit
		1:200
		Fieta Nr.
		14

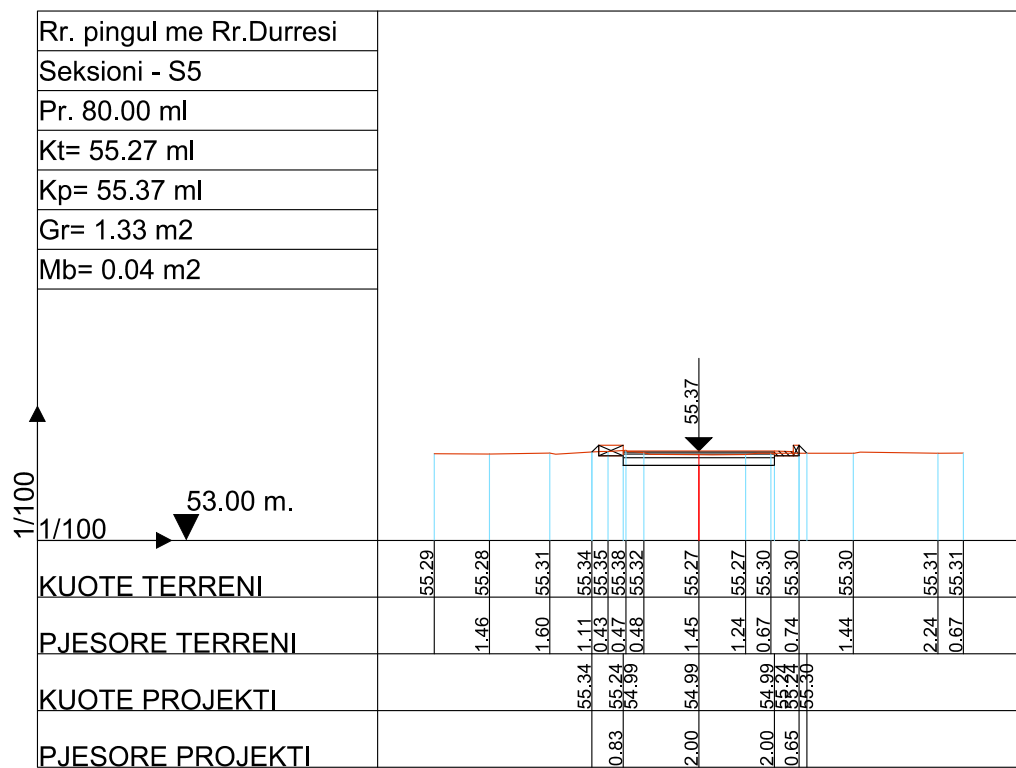
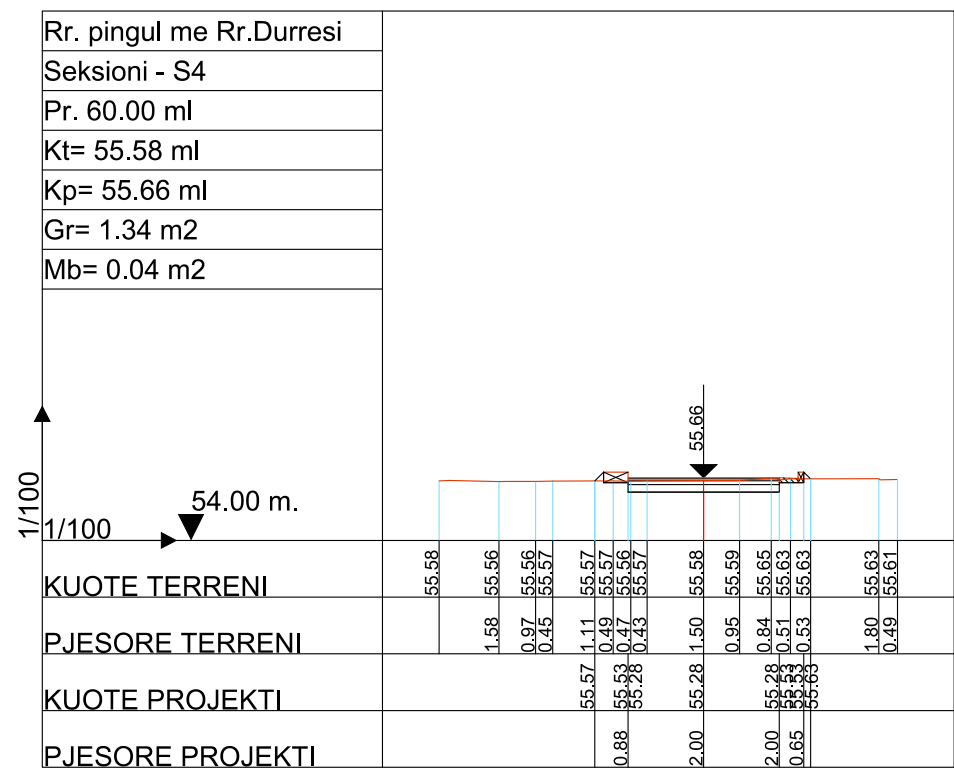
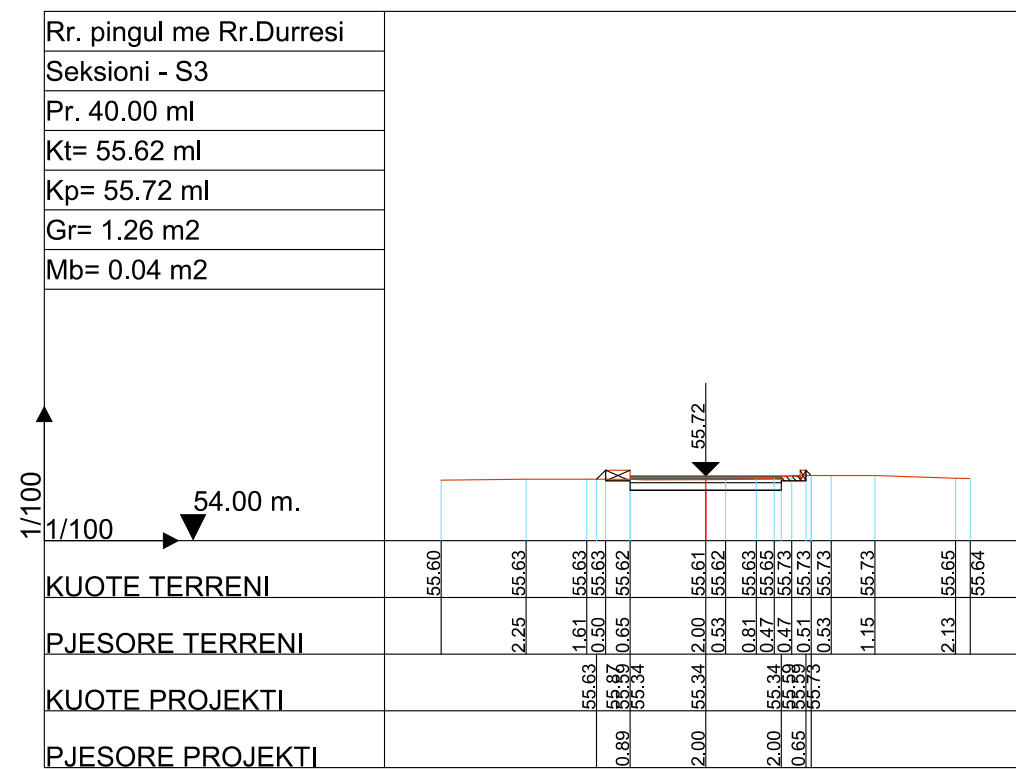
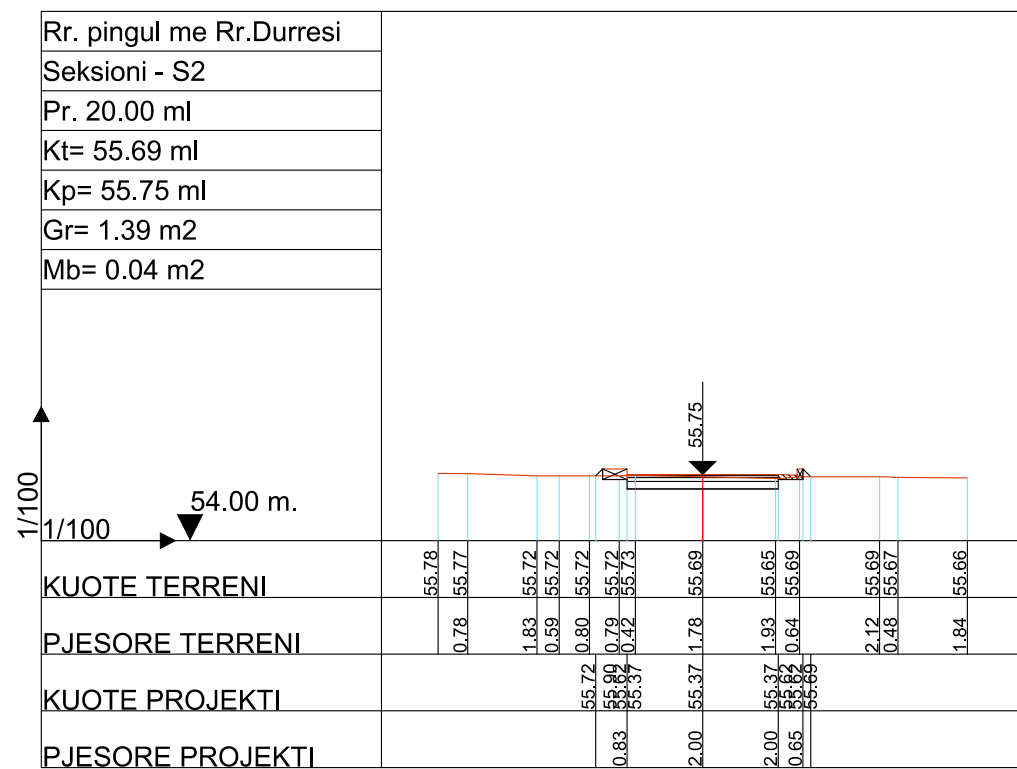



BASHKIA KAMEZ
DREJTORIA E SHERBIMEVE PUBLIKE
DREJTORIA E PROJEKTEVE DHE INVESTIMEVE
DEPARTAMENTI I PROJEKTEVE

Dr. e Projekteve e Investimeve	FLORA MUCA
--------------------------------	------------

STAFI TEKNIK	Ing. ARJOLA KURTI
PROJEKTUES	Ing. ERBLIN LALA
	Ing. DENIS PRENCI
	Ing. RAMADAN HYSA

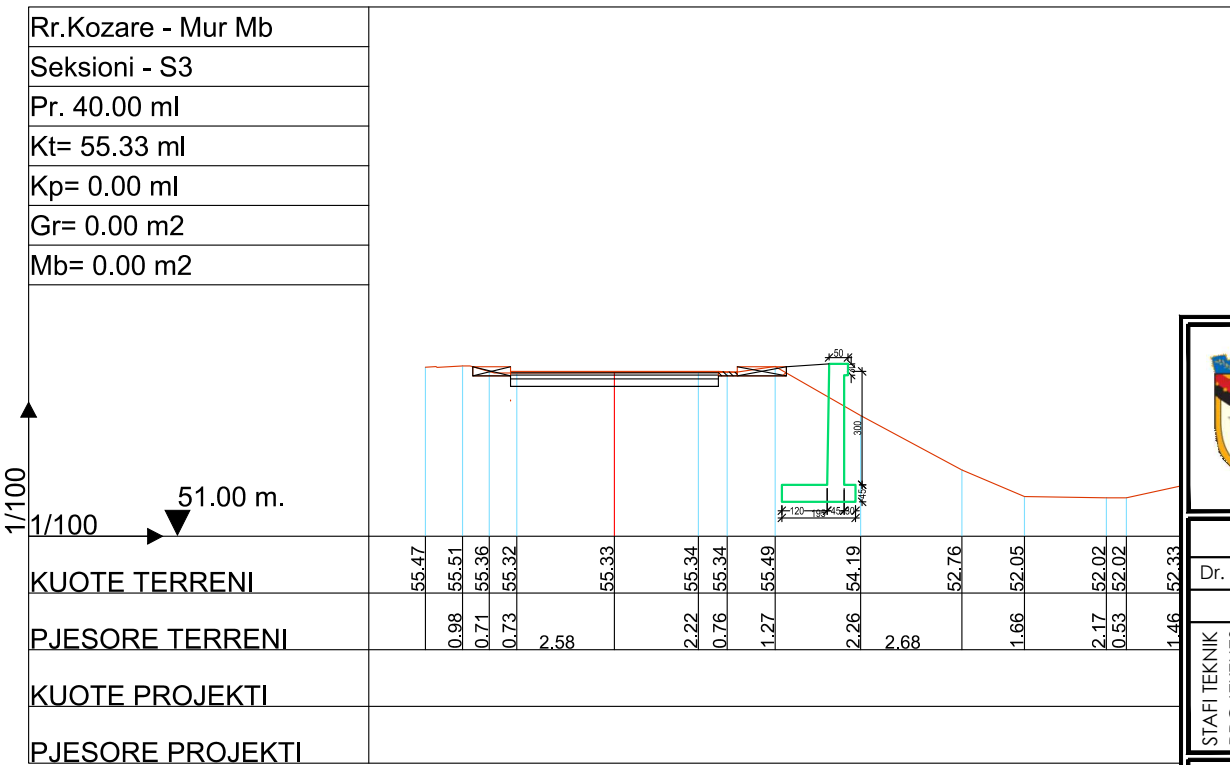
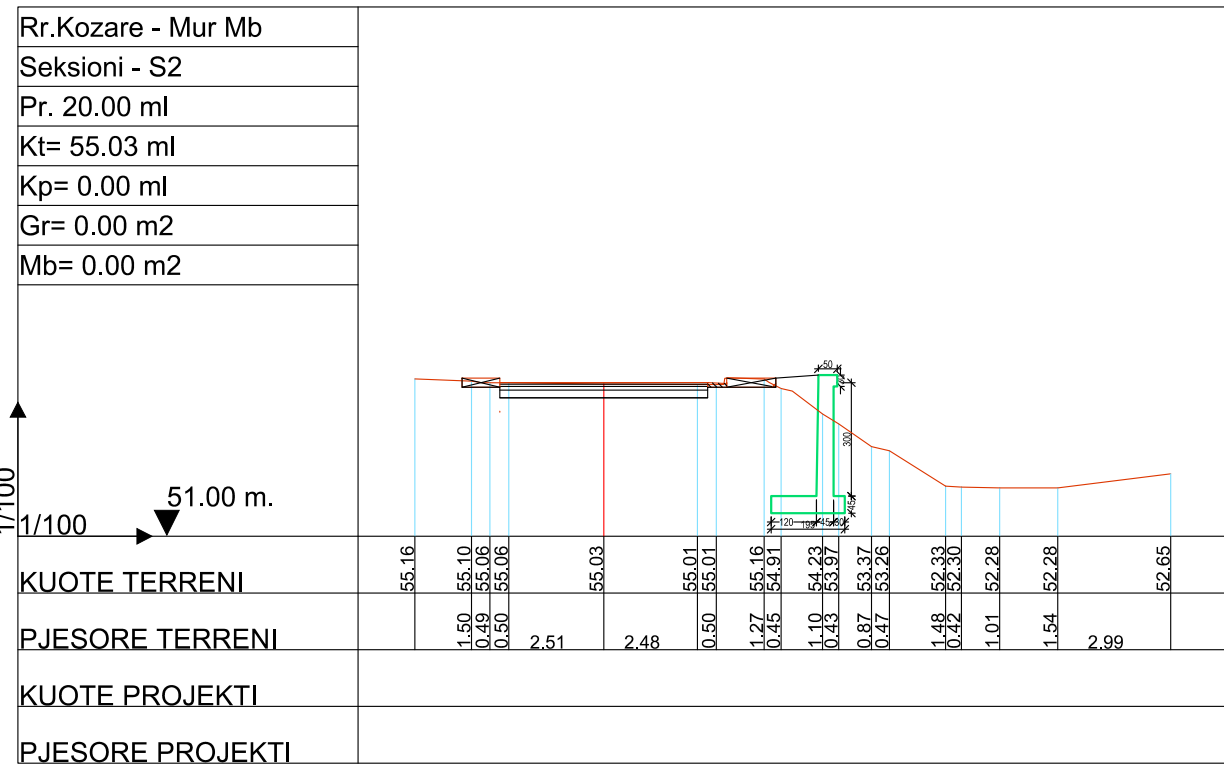
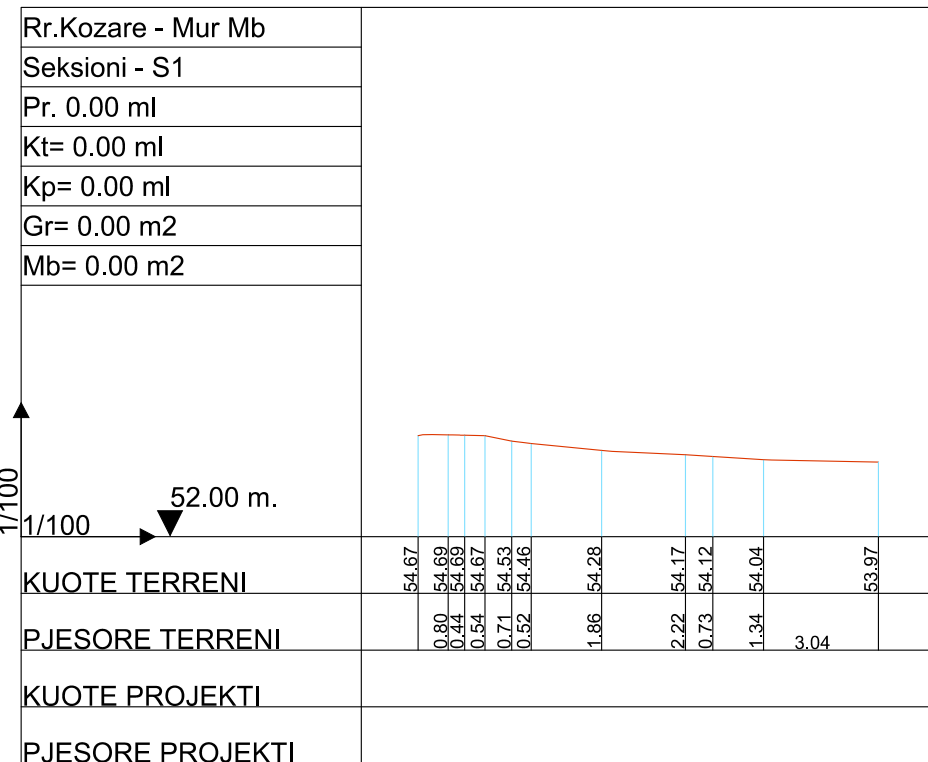
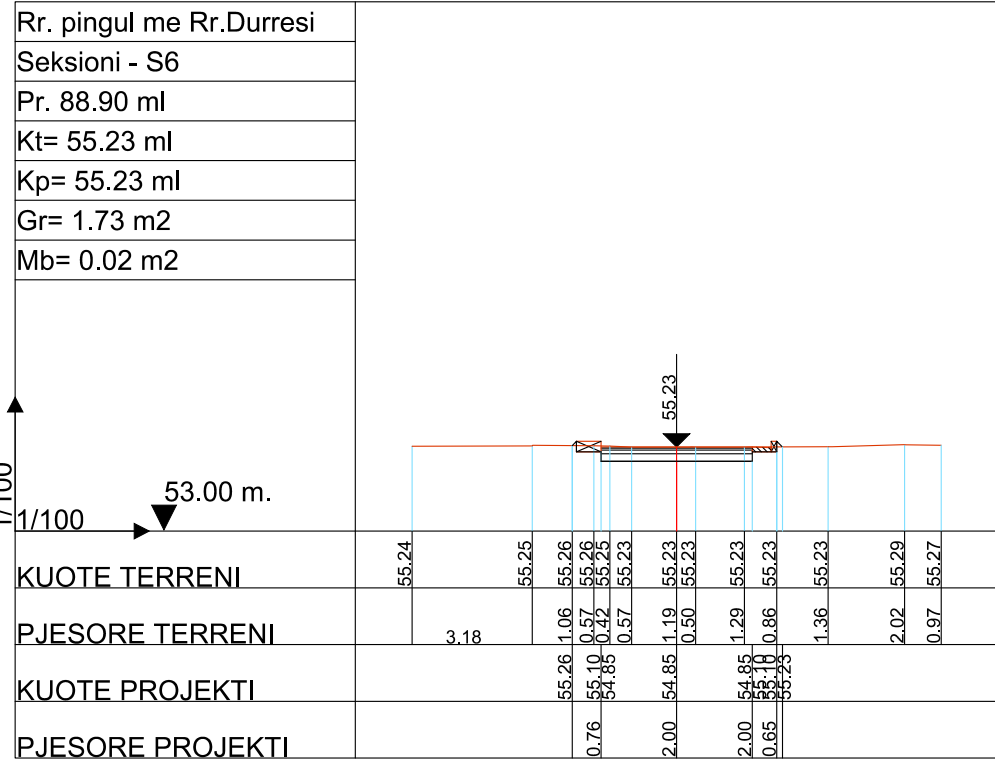
Titulli i Projektit	RIKONSTRUKSION RRUGA "LUNXHERI", NDERTIM RRUGA PARALEL ME RR "LUNXHERI", PINGUL ME RR "DURRESI", PINGUL ME RR "LURA", RRUGA "KORCE", MUR MBAJTES RRUGA "KOZAR"
Faza e Projektit	PROJEKT ZBATIMI
Data e Implementimit	
Shkalla e Vizatimit	1:200
Emertimi i Fletes	PROFLET TERTHORE
Fieta Nr.	



BASHKIA KAMEZ
 DREJTORIA E SHERBIMEVE PUBLIKE
 DREJTORIA E PROJEKTEVE DHE INVESTIMEVE
 DEPARTAMENTI I PROJEKTEVE

Dr. e Projekteve e Investimeve	FLORA MUCA
STAFI TEKNIK PROJEKTES	Ing. ARJOLA KURTI Ing. ERBLIN LALA Ing. DENIS PRENCI Ing. RAMADAN HYSA

Titulli i Projektit	RIKONSTRUKSION RRUGA "LUNXHERI", NDERTIM RRUGA PARALEL ME RR "LUNXHERI", PINGUL ME RR "DURRESI", PINGUL ME RR "LURA", RRUGA "KORCE", MUR MBAJTES RRUGA "KOZAR"
Faza e Projektit	PROJEKT ZBATIMI
Data e Implementimit	
Shkalla e Vizatimit	1:200
Emertimi i Fletes	PROFLET TERTHORE
Fieta Nr.	16

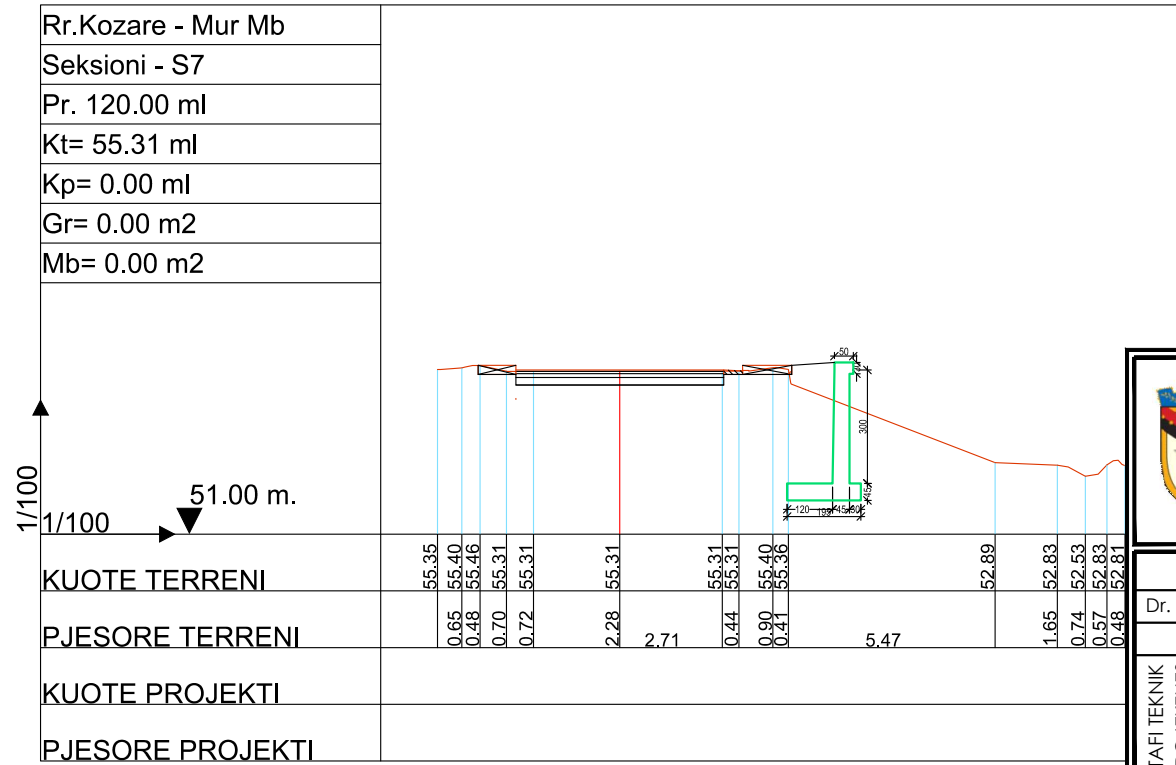
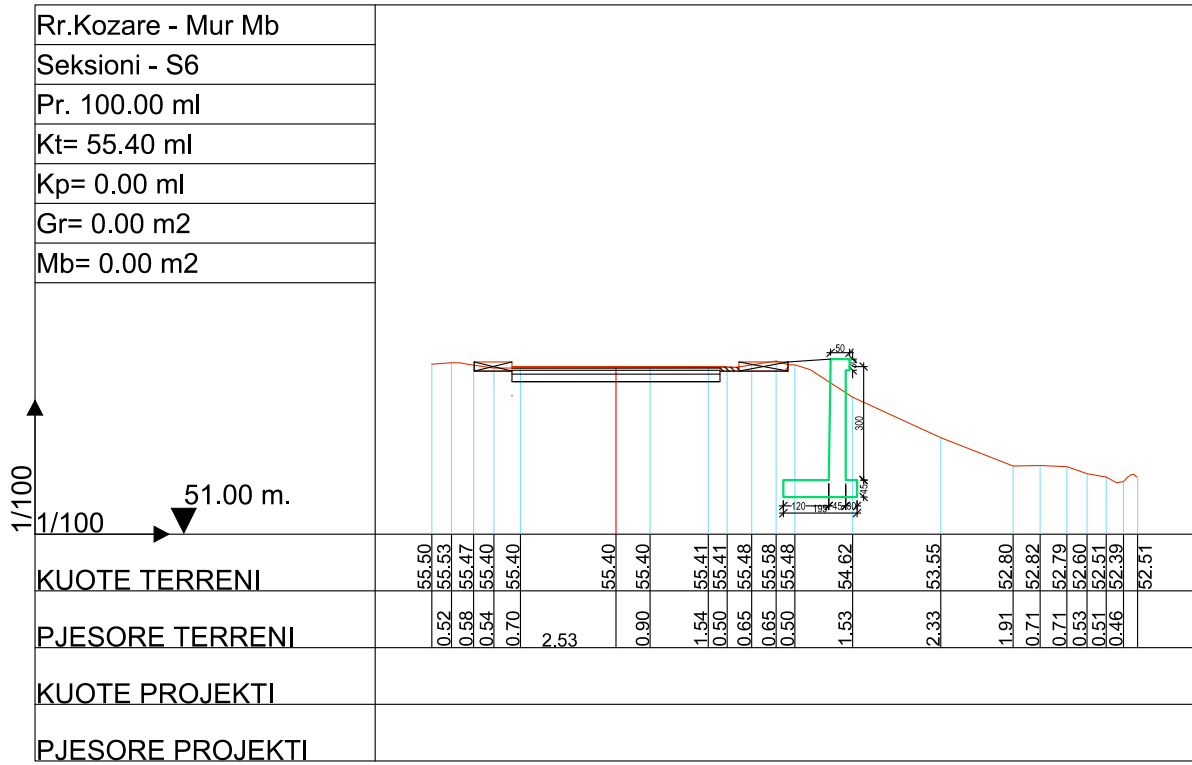
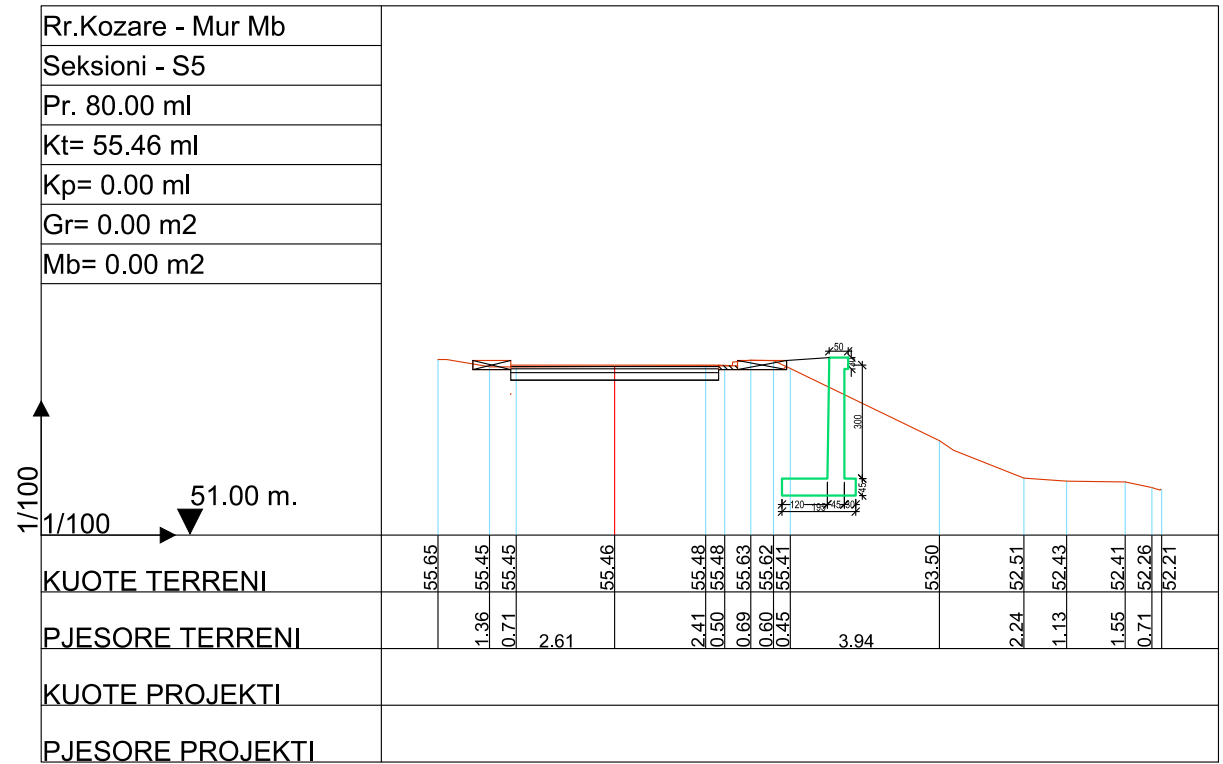
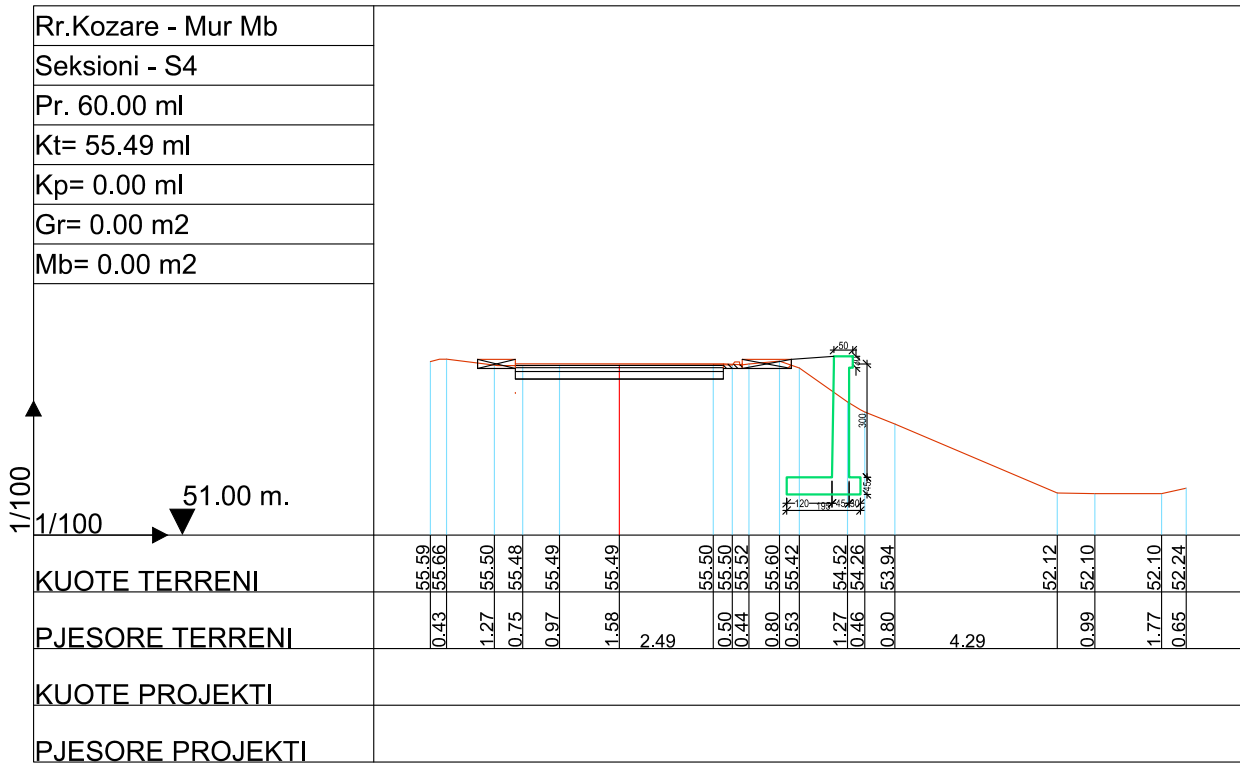

BASHKIA KAMEZ
 DREJTORIA E SHERBIMEVE PUBLIKE
 DREJTORIA E PROJEKTEVE DHE INVESTIMEVE
 DEPARTAMENTI I PROJEKTEVE

Dr. e Projekteve e Investimeve	FLORA MUCA
STAFI TEKNIK PROJEKTES	Ing. ARJOLA KURTI
	Ing. ERBLIN LALA
	Ing. DENIS PRENCI
	Ing. RAMADAN HYSA

Titulli i Projektit	RIKONSTRUKSION RRUGA "LUNXHERI", NDERTIM RRUGA PARALEL ME RR "LUNXHERI", PINGUL ME RR "DURRESI", PINGUL ME RR "LURA", RRUGA "KORCE", MUR MBAJTES RRUGA "KOZAR"
Faza e Projektit	PROJEKT ZBATIMI
Data e Implementimit	
Shkalla e Vizatimit	1:200
Emertimi i Fletes	PROFLET TERTHORE
Fleta Nr.	17

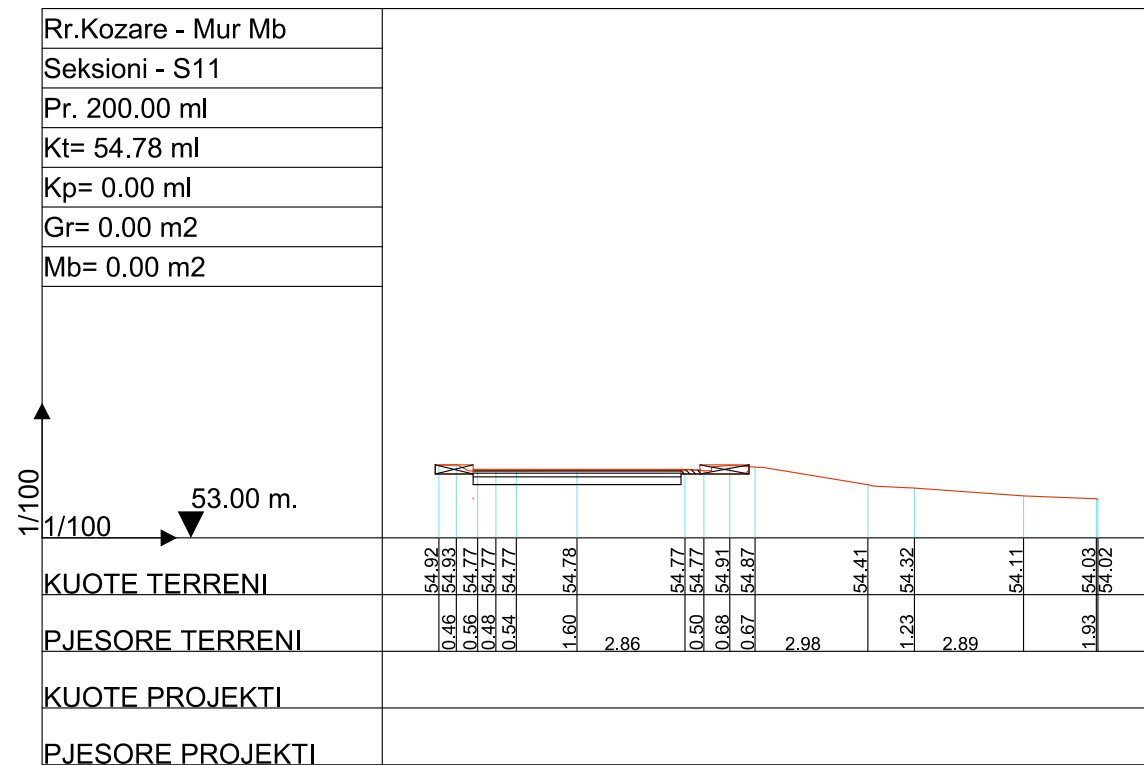
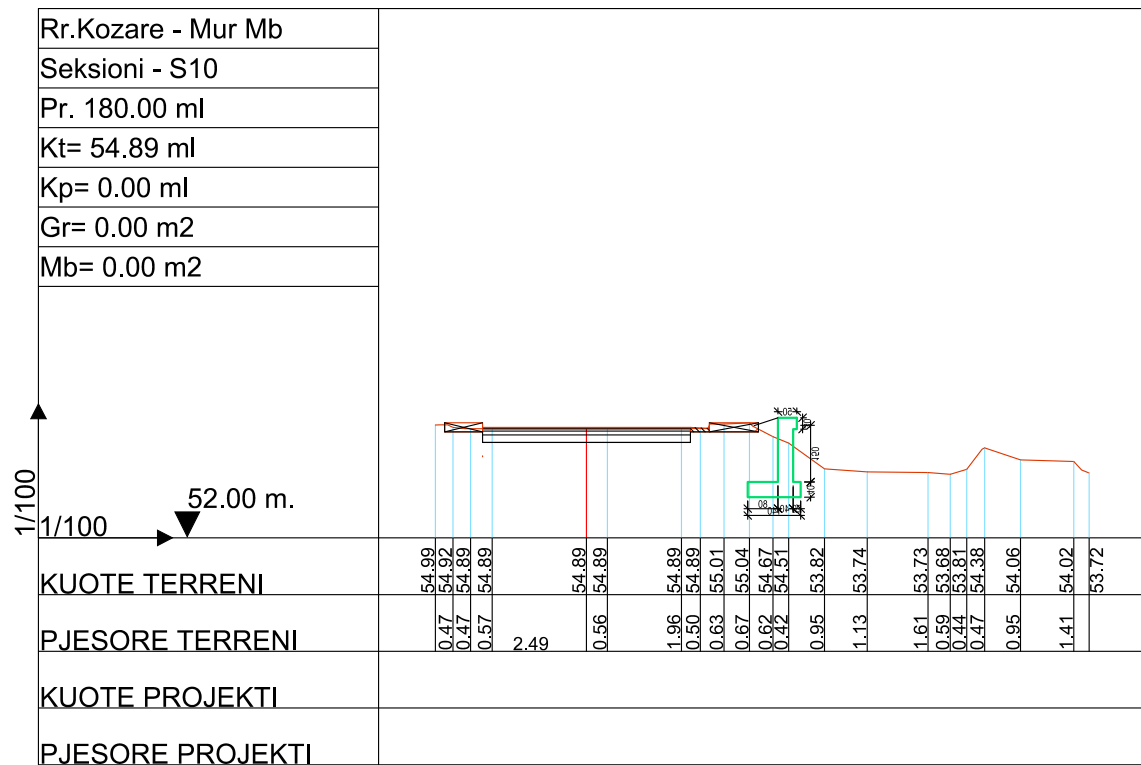
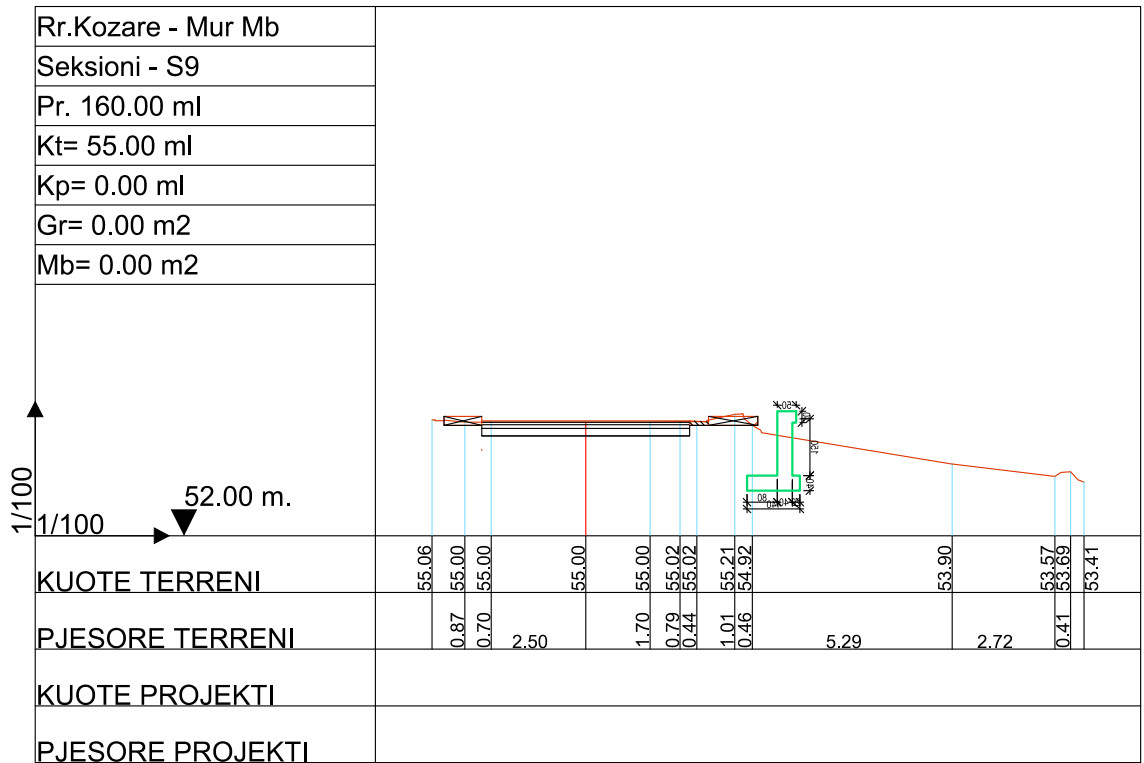
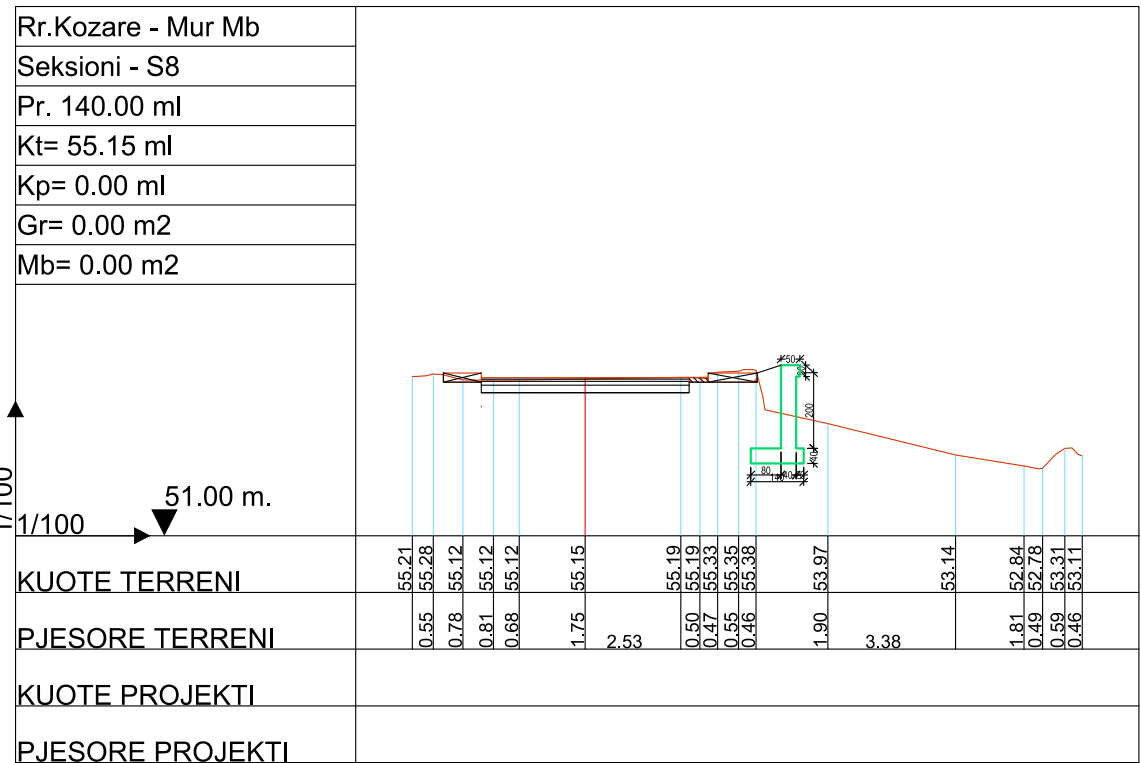



BASHKIA KAMEZ
DREJTORIA E SHERBIMEVE PUBLIKE
DREJTORIA E PROJEKTEVE DHE INVESTIMEVE
DEPARTAMENTI I PROJEKTEVE

Dr. e Projekteve e Investimeve	FLORA MUCA
STAFI TEKNIK PROJEKTES	Ing. ARJOLA KURTI
	Ing. ERBLIN LALA
	Ing. DENIS PRENCI
	Ing. RAMADAN HYSA

Titulli i Projektit	Rikonstruksion Rruga "Lunxheri", ndertim rruga paralel me rr "Lunxheri", pingul me rr "Durrresi", pingul me rr "Lura", rruga "Korce", mur mbajtes rruga "Kozar"
Faza e Projektit	PROJEKT ZBATIMI
Data e Implementimit	
Shkalla e Vizatimit	1:200
Emertimi i Fletes	PROFLET TERTHORE
Fieta Nr.	18

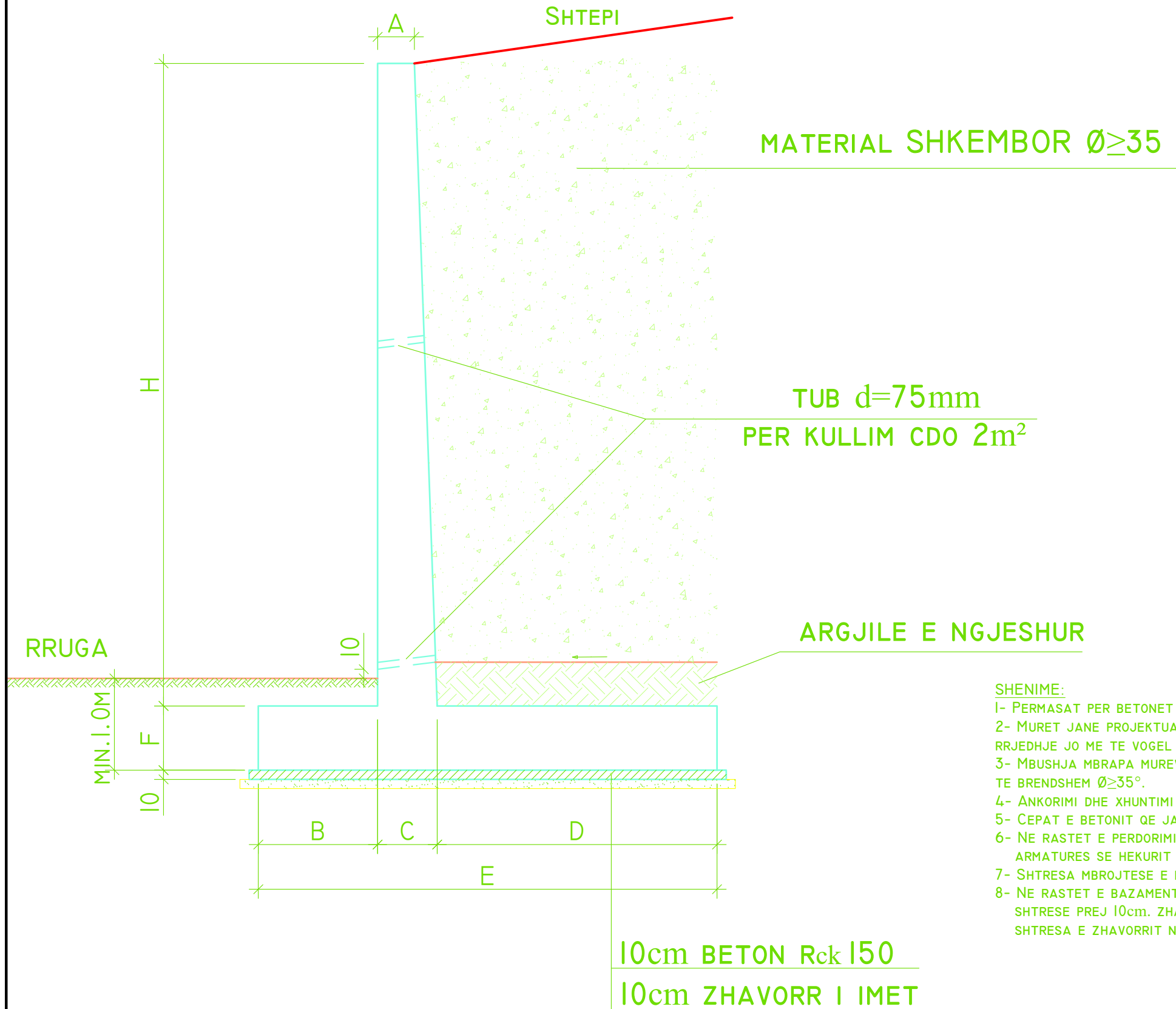
MUR MBAJTES TIP ARKITEKTURA



SHENIME:

- 1- PERMASAT PER BETONET JANE DHENE NE cm. NDERSA PER HEKURAT NE mm.
- 2- MURET JANE PROJEKTUAR ME BETON Rck-300. ARMATURA E HEKURIT DUHET TE KETE REZISTENCE NE RRJEDHJE JO ME TE VOGEL SE 3200kg/cm² QE E KENAQ HEKURI Feb-40K.
- 3- MBUSHJA MBRAPA MUREVE DUHET TE BEHET ME MATERIAL SHKEMBOR PA DHERA ME KEND TE FERKIMIT TE BRENDSHEM Ø≥35°.
- 4- ANKORIMI DHE XHUNTIMI I HEKURAVE DO TE BEHET ME MBUSHJE ME MATERIAL SHKEMBOR.
- 5- CEPAT E BETONIT QE JANE TE EKSPOZUAR DUHET TE RRUMBULLOHE ME RREZE r=20mm.
- 6- NE RASTET E PERDORIMIT TE LARTESIVE NDERMJETESE PER MBUSHJE ME MATERIAL SHKEMBOR, ARMATURES SE HEKURIT DUHET TE APLIKOHEN ATO TE LAJMI.
- 7- SHTRESA MBROJTESE E BETONIT NGA SKAJI I JASHEM DUHET TE JETE ME GRESHTE PRANUAR 30mm.
- 8- NE RASTET E BAZAMENETEVE PREJ DHERASH SHTRESA E MBROJTESE E BETONIT TE VARFET 10cm, VENDOSET MBI NJE SHTRESA PREJ 10cm. ZHAVORRI TE IMET. NE RASTET E DHERASH SHTRESA E ZHAVORRIT NUK ESHTHE E NEVOJSHME.



BASHKIA KAMEZ

DREJTORIA E SHERBIMEVE PUBLIKE
DREJTORIA E PROJEKTEVE DHE INVESTIMEVE
DEPARTAMENTI I PROJEKTEVE

ABANEVE SHKEMBOR E GJYSEM SHKEMBOR.		
Dr. e Projekteve e Investimeve	FLORA MUCA	
STAFI TEKNIK	Ing. RAMADAN HYSA	
PROJEKTUES	Ing. ERBLIN LALA	
	Ing. DENIS PRENCI	
	Ing. NDERIM PASHA	
Titulli i Projektit		Faza e Projektit
RIKONSTRUKSION RRUGA "LUNXHERI", NDERTIM RRUGA PARALEL ME RR "LUNXHERI", PINGUL ME RR "DURRESI", PINGUL ME RR "LURA", RRUGA "KORCE", MUR MBAJTES RRUGA "KOZAR"		PROJEKT ZBATIMI
Emertimi i Fletes		Data e Implementimit :
DETAJ MUR MBAJTES		Shkalla e Vizatimit
		1:50
		Fleta Nr.

PLANI I GERMIMIT TE DHEUT

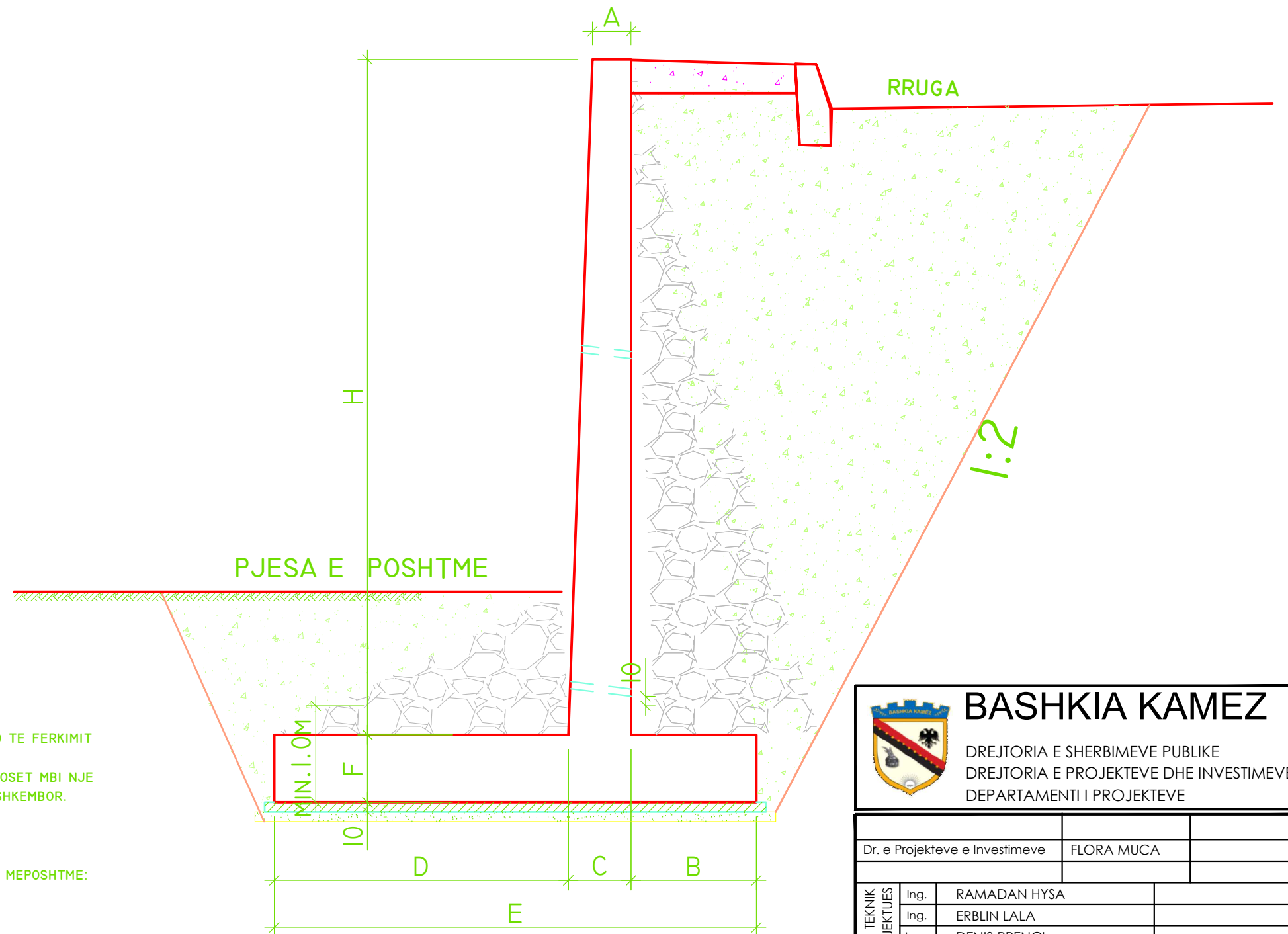

SHENIME:

- 1- GERMIMI I DHEUT TE BEHET ME ESKAVATOR I NJE KAPACITETI TE CFARDOSHEM, RREKOMANDOHET ESKAVATOR LOPAT KUNDERT ME KAPACITET KOVE I M3.
- 2- GERMIMI TE BEHET ME KUJDES PASI VETE BAZAMENTI NUK ESHTË I QENDRUESHEM DHE KERKON TE BEHET ME BREZA.
- 3- MBUSHJA MBRAPA MUREVE DUHET TE BEHET ME MATERIAL SHKEMBOR PA DHERA ME KEND TE FERKIMIT TE BRENDSHEM $\varnothing \geq 35^\circ$ SIC TREGOHET NE FIGURE.
- 4- NE RASTET E BAZAMENTEVE PREJ DHERASH SHTRESA E BETONIT TE VARFER 10cm. VENDOSËT MBI NJE SHTRESA PREJ 10cm. ZHAVORRI TE IMET. NE RASTET E TABANEVE SHKEMBOR E GJYSEM SHKEMBOR. SHTRESA E ZHAVORRIT NUK ESHTË E NEVOJSHME.
- 5- VELLIMI I GERMIMIT TE DHEUT TE LLOGARITËME FORMULEN E MEPOSHTME:

$$V = (2 \cdot D + H + F + 0.3) \cdot (H + F) \cdot l_{MURIT} / 2.$$
- 6- VELLIMI I MBUSHJES ME GURE ME PARAMETRAT E MESIPERM LLOGARITËME FORMULEN E MEPOSHTME:

$$V = (D + H) \cdot l_{MURIT} / 2.$$

 BASHKIA KAMEZ DREJTORIA E SHERBIMEVE PUBLIKE DREJTORIA E PROJEKTEVE DHE INVESTIMEVE DEPARTAMENTI I PROJEKTEVE		Dr. e Projekteve e Investimeve		FLORA MUCA
		STAFI TEKNIK PROJEKTUES		Ing. RAMADAN HYSA
		Ing. ERBLIN LALA		
		Ing. DENIS PRENCI		
		Ing. NDERIM PASHA		
Titulli i Projektit RIKONSTRUKSION RRUGA "LUNXHERI", NDERTIM RRUGA PARALEL ME RR "LUNXHERI", PINGUL ME RR "DURRESI", PINGUL ME RR "LURA", RRUGA "KORCE", MUR MBAJTËS RRUGA "KOZAR"			Faza e Projektit PROJEKT ZBATIMI	
Emertimi i Fletes DETAJ MUR MBAJTËS			Data e Implementimit : Shkalla e Vizatimit 1:50 Fleta Nr.	

MURE MBAJTES B/ARME H=2M
 $[\sigma]_t=2\text{kg/cm}^2$ DHE 4kg/cm^2 , $\phi_m \geq 35^\circ$
 SH. 1:25



TABELA E HEKURAVE
 PER $[\sigma]_t=2\text{kg/cm}^2$ DHE 4kg/cm^2

NR.	Ø mm	L mm	SASIA cope	L m	PERMBLEDHJE E ARMATURES.				
					Ø mm	ΣL m	PESHA kg/ml	PESHA kg	
1	12	2805	7	19.64	6	7.28	0.222	1.62	
2	12	2805	5	14.03	8	7.16	0.395	2.83	
3	12	1000	20	20.00	12	96.39	0.888	88.26	
3a	14	1000	3	3.00	14	3.00	1.208	3.62	
4	12	1908	7	13.36					
5	12	1908	7	13.36					
6	12	1000	16	16.00					
7	6	520	6	3.12					
8	6	520	8	4.16					
9	8	1432	5	7.16					
							SHUMA	kg/ml	96.33
BETON Rck=300kg/cm²							m³/ml	1.47	

SHENIME:

- MURI ESHTË PROJEKTUAR PER:
 - NGARKESE TE LEVIZESHME NE PRIZMIN E SHKATERIMIT $q=1.7\text{T/m}^2$
 - MBUSHJE MBRAPA TIJ ME MATERIAL SHKEMBOR ME KEND TE FERKIMIT TE MBRENDSEME $\phi \geq 35^\circ$.
 - NGARKESE TE LEJUAR NE TABAN $[\sigma]=2\text{kg/cm}^2$ DHE 4kg/cm^2
- MURI ESHTË PARASHIKUAR TE NDERTOHE:
 - ME BETON Rck=300kg/cm²
 - ARMATURE PREJ CELIKU Feb-44K.
- LARGESIA NGA FAQJA E BETONIT DERI TEK FAQJA E ARMATURES PUNUESE DO TE MERRET 40mm.
- PERMASAT E BETONIT JANE DHENE NE CENTIMETRA (cm), TE ARMATURES SE HEKURIT NE MILIMETRA (mm).
- DETAJI I FIKSIMIT TE PARAPETIT METALIK JEPET ME PROJEKT TE VECANTE.

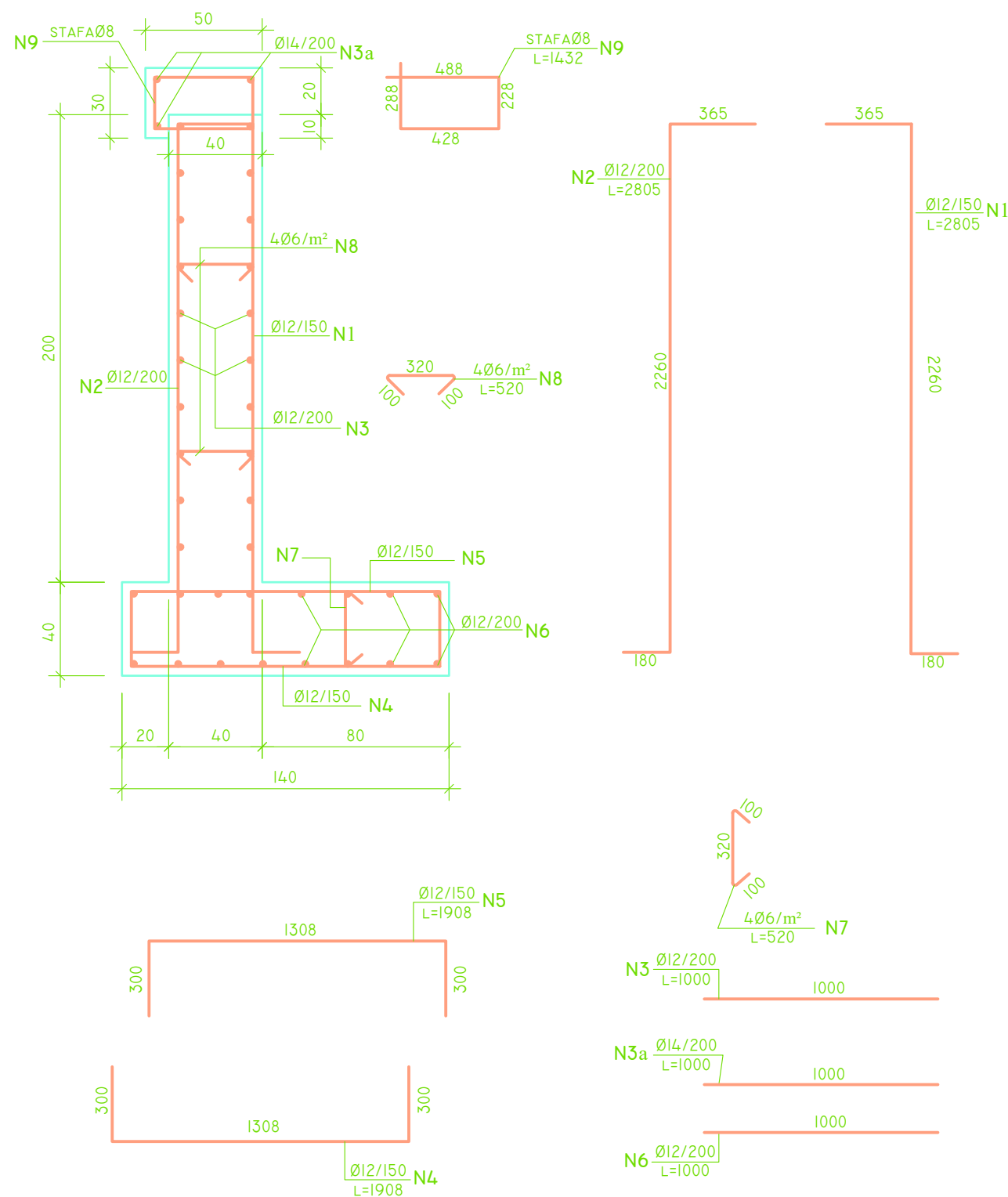
BASHKIA KAMEZ
 DREJTORIA E SHERBIMEVE PUBLIKE
 DREJTORIA E PROJEKTEVE DHE INVESTIMEVE
 DEPARTAMENTI I PROJEKTEVE

Dr. e Projekteve e Investimeve	FLORA MUCA
STAFI TEKNIK PROJEKTES	Ing. RAMADAN HYSA Ing. ERBLIN LALA Ing. DENIS PRENCI Ing. NDERIM PASHA

Titulli i Projektit RIKONSTRUKSION RRUGA "LUNXHERI", NDERTIM RRUGA PARALEL ME RR "LUNXHERI", PINGUL ME RR "DURRESI", PINGUL ME RR "LURA", RRUGA "KORCE", MUR MBAJTES RRUGA "KOZAR"	Faza e Projektit PROJEKT ZBATIMI Data e Implementimit : Shkalla e Vizatimit 1:50 Fieta Nr.
Emertimi i Fletes DETAJ MUR MBAJTES	

MURE MBAJTES B/ARME H=3M
 $[\sigma]_t=2\text{kg/cm}^2$ DHE 4kg/cm^2 , $\phi_m \geq 35^\circ$
 SH. 1:25



TABELA E HEKURAVE
 PER $[\sigma]_t=2\text{kg/cm}^2$ DHE 4kg/cm^2

NR.	Ø mm	L mm	SASIA cope	L m	PERMBLEDHJE E ARMATURES.			
					Ø mm	ΣL m	PESHA kg/ml	PESHA kg
1	12	3956	7	27.69	6	11.10	0.222	2.46
2	12	3955	5	19.78	8	7.16	0.395	2.83
3	12	1000	30	30.00	12	135.29	0.888	120.14
3a	14	1000	3	3.00	14	3.00	1.208	3.62
4	12	2558	7	17.91				
5	12	2558	7	17.91				
6	12	1000	22	22.00				
7	6	570	8	4.56				
8	6	545	12	6.54				
9	8	1432	5	7.16				
SHUMA							kg/ml	129.05
BETON Rck=300kg/cm²							m³/ml	2.26

SHENIME:

- MURI ESHTË PROJEKTUAR PER:
 - NGARKESE TE LEVIZESHME NE PRIZMIN E SHKATERIMIT $q=1.7\text{T/m}^2$
 - MBUSHJE MBRAPA TIJ ME MATERIAL SHKEMBOR ME KEND TE FERKIMIT TE MBRENDSEME $\phi \geq 35^\circ$.
 - NGARKESE TE LEJUAR NE TABAN $[\sigma]=2\text{kg/cm}^2$ DHE 4kg/cm^2
- MURI ESHTË PARASHIKUAR TE NDERTOHE:
 - ME BETON Rck=300kg/cm²
 - ARMATURE PREJ CELIKU Feb-44k.
- LARGESIA NGA FAQJA E BETONIT DERI TEK FAQJA E ARMATURES PUNUESE DO TE MERRET 40mm.
- PERMASAT E BETONIT JANE DHENE NE CENTIMETRA (cm), TE ARMATURES SE HEKURIT NE MILIMETRA (mm).
- DETAJI I FIKSIMIT TE PARAPETIT METALIK JEPET ME PROJEKT TE VECANTE.

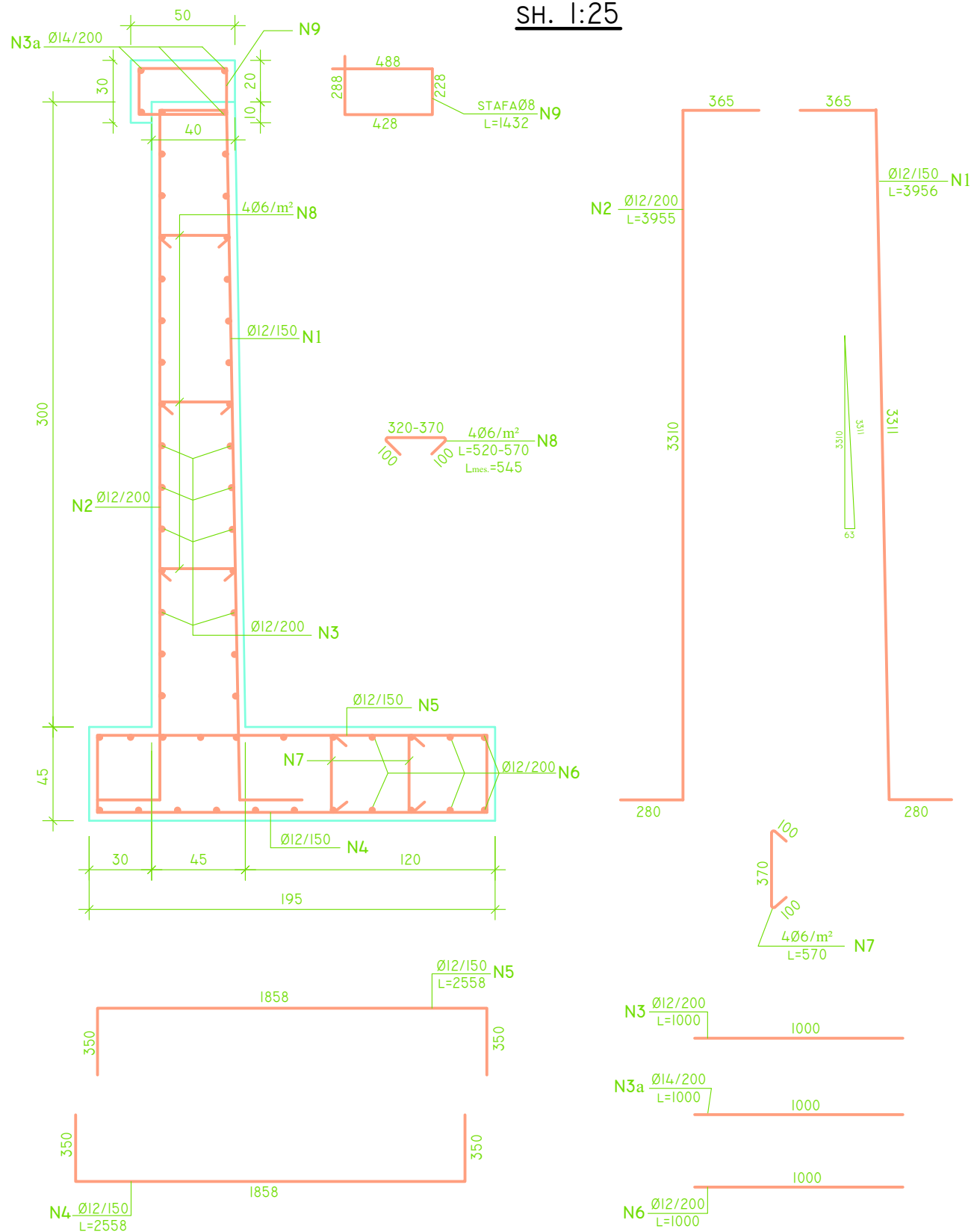
SHENIME:

- NE KETE OBJEKT DO TE ZBATOHE MURI ME H=3M

BASHKIA KAMEZ
 DREJTORIA E SHERBIMEVE PUBLIKE
 DREJTORIA E PROJEKTEVE DHE INVESTIMEVE
 DEPARTAMENTI I PROJEKTEVE

Dr. e Projekteve e Investimeve	FLORA MUCA
STAFI TEKNIK PROJEKTES	Ing. RAMADAN HYSA Ing. ERBLIN LALA Ing. DENIS PRENCI Ing. NDERIM PASHA

Titulli i Projektit	RIKONSTRUKSION RRUGA "LUNXHERI", NDERTIM RRUGA PARALEL ME RR "LUNXHERI", PINGUL ME RR "DURRESI", PINGUL ME RR "LURA", RRUGA "KORCE", MUR MBAJTES RRUGA "KOZAR"
Faza e Projektit	PROJEKT ZBATIMI
Data e Implementimit	
Shkalla e Vizatimit	1:50
Emertimi i Fletes	DETAJ MUR MBAJTES
Fleta Nr.	

NGRTIJE PUSETE

PRERJE 1-1 Sh 1:20

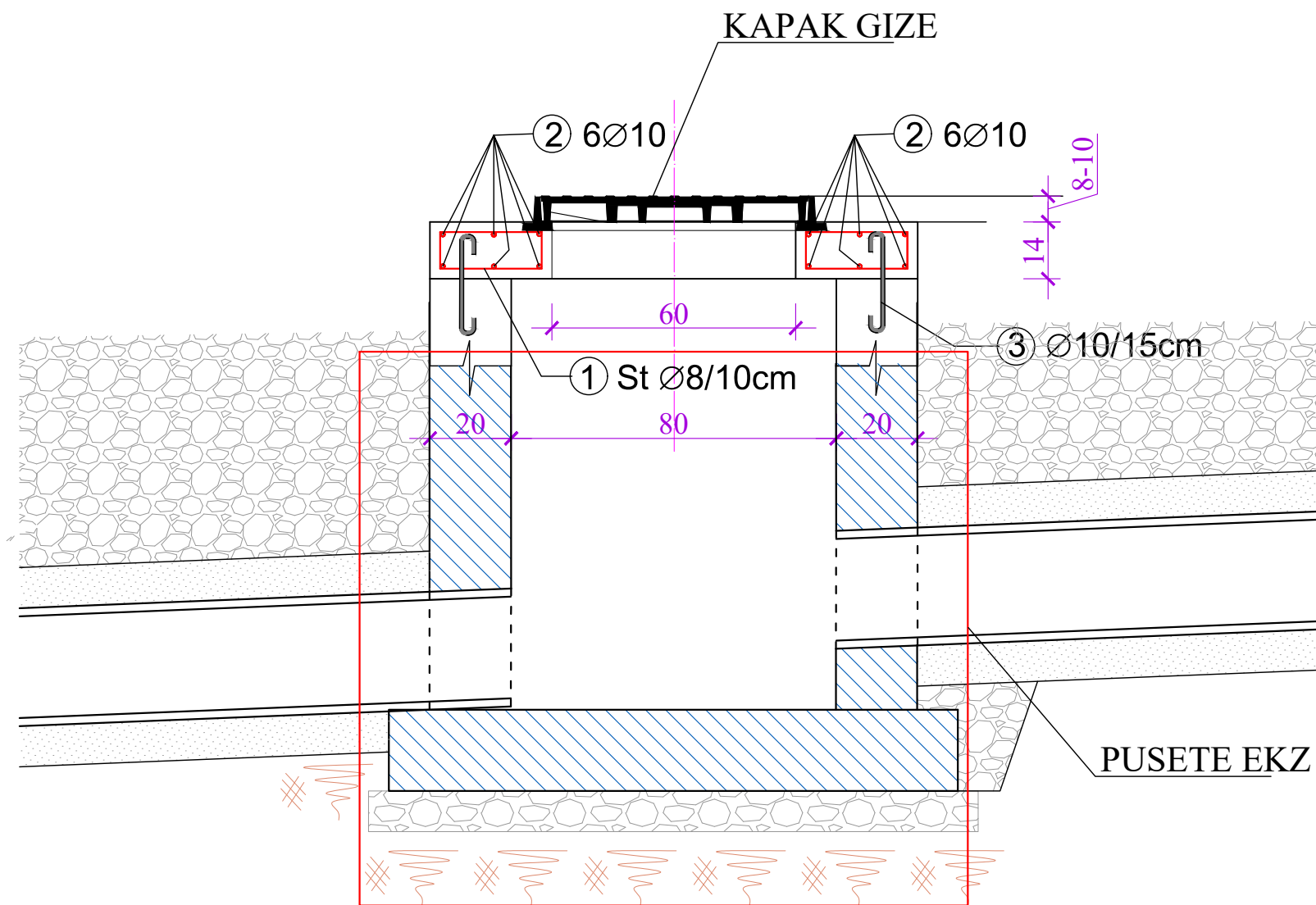

PRERJE 1-1 Sh 1:20

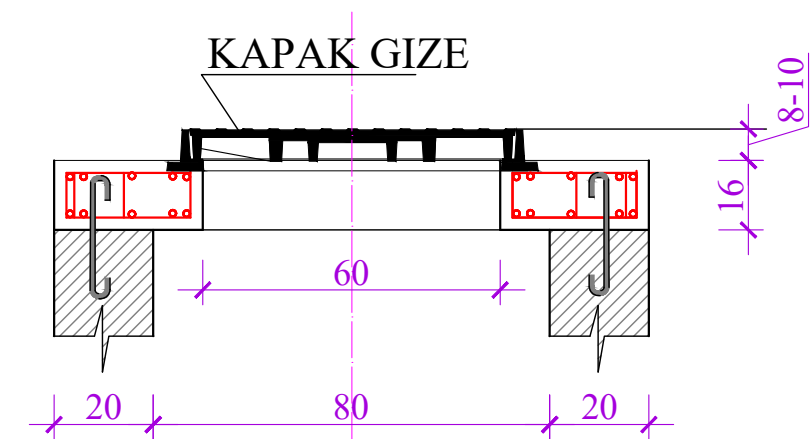

 BASHKIA KAMEZ DREJTORIA E SHERBIMEVE PUBLIKE DREJTORIA E PROJEKTEVE DHE INVESTIMEVE DEPARTAMENTI I PROJEKTEVE		
Dr. e Projekteve e Investimeve		FLORA MUCA
STAFI TEKNIK PROJEKTUES	Ing. RAMADAN HYSA	
	Ing. ERBLIN LALA	
	Ing. DENIS PRENCI	
	Ing. NDERIM PASHA	
RIKONSTRUKSION RRUGA "LUNXHERI", NDERTIM RRUGA PARALEL ME RR "LUNXHERI", PINGUL ME RR "DURRESI", PINGUL ME RR "LURA", RRUGA "KORCE", MUR MBAJTES RRUGA "KOZAR"		Faza e Projektit PROJEKT ZBATIMI
Emertimi i Fletes DETAJE		Data e implementimit : Shkalla e Vizatimit Fleta Nr.
		14

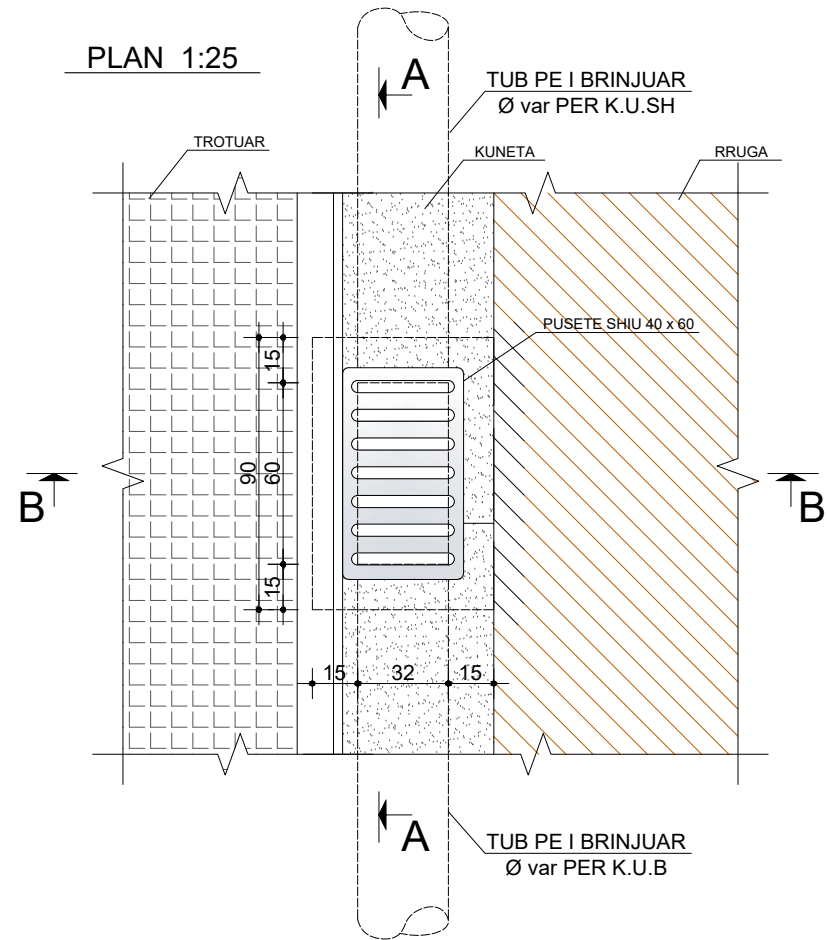

PRERJE A-A 1:25

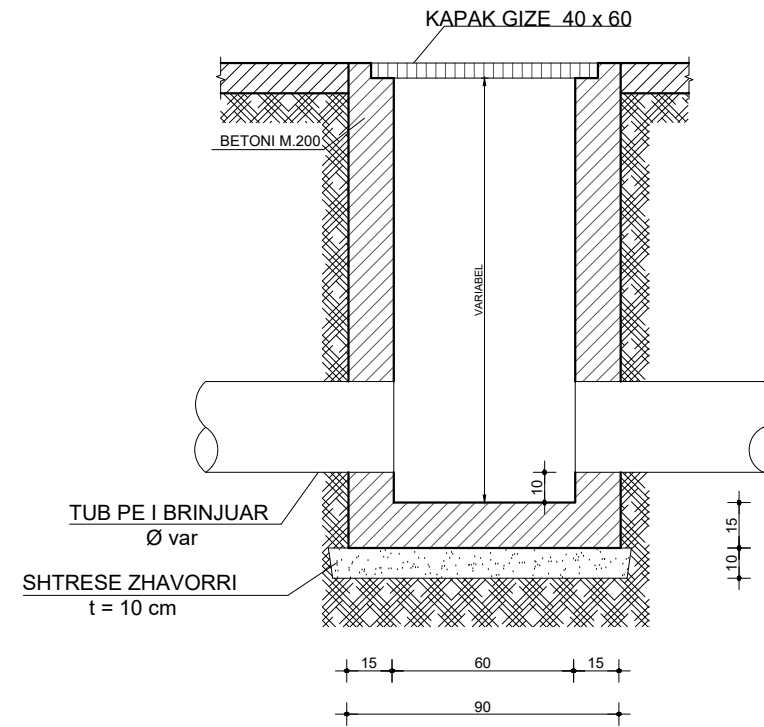

**PRERJE B-B 1:25
(PER TUBA PE D=315mm)**

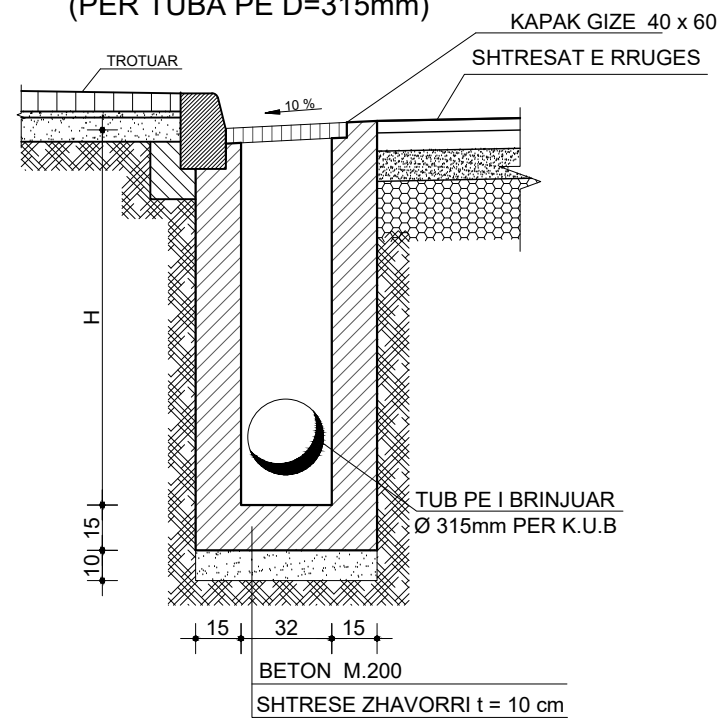

**PRERJE B-B 1:20
(PER TUBA PE D=315)**

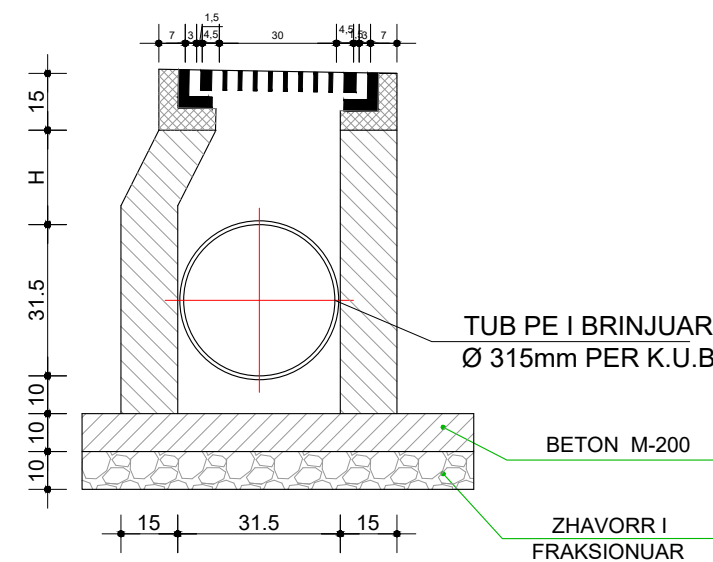

BASHKIA KAMEZ

DREJTORIA E SHERBIMEVE PUBLIKE
DREJTORIA E PROJEKTEVE DHE INVESTIMEVE
DEPARTAMENTI I PROJEKTEVE

Dr. e Projekteve e Investimeve	FLORA MUCA
STAFI TEKNIK PROJEKTES	Ing. RAMADAN HYSA Ing. ERBLIN LALA Ing. DENIS PRENCI Ing. NDERIM PASHA

Titulli i Projektit RIKONSTRUKSION RRUGA "LUNXHERI", NDERTIM RRUGA PARALEL ME RR "LUNXHERI", PINGUL ME RR "DURRESI", PINGUL ME RR "LURA", RRUGA "KORCE", MUR MBAJTES RRUGA "KOZAR"	Faza e Projektit PROJEKT ZBATIMI Data e Implementimit : Shkalla e Vizatimit 1:50 Flota Nr. 01
Emertimi i Fletes DETAJE	

DETAJI PANDUSIT

PRERJA A-A SHK.1:50

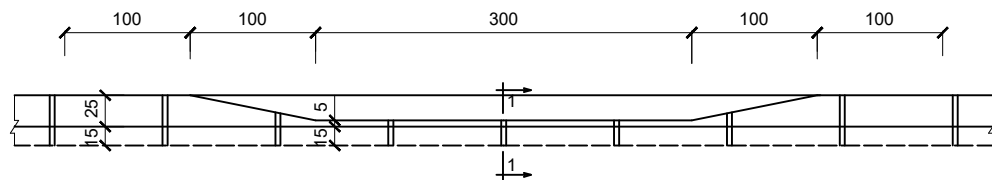

PLAN SHK.1:50

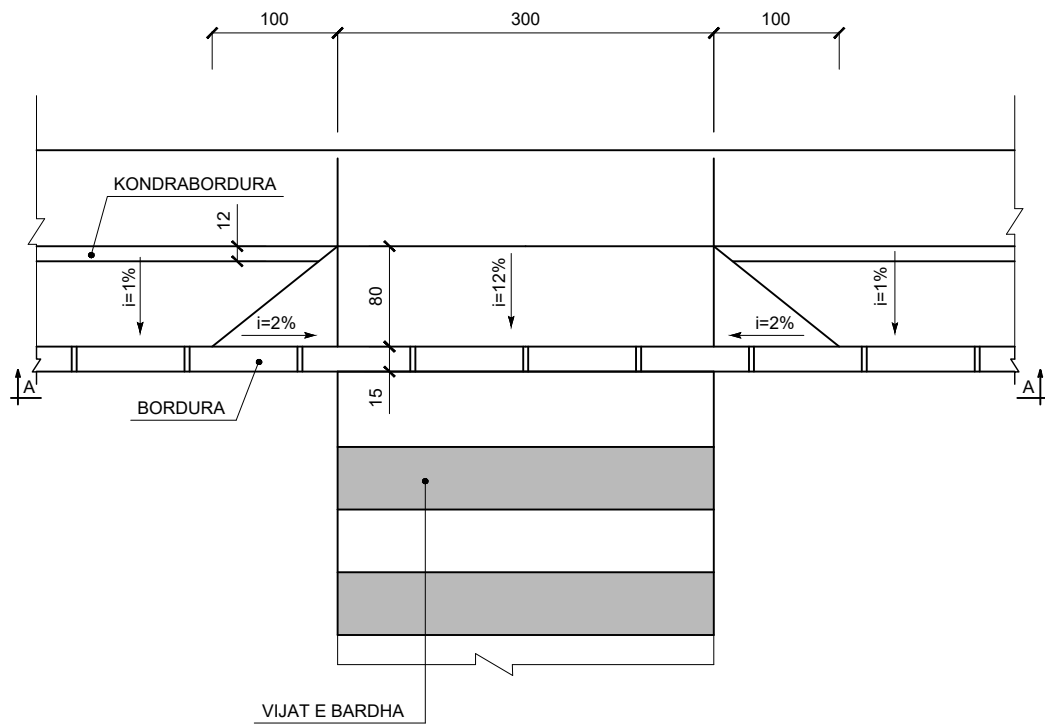

Shënim:
NE CDO PIKE KU KRYQEZOHET RRUGA KRYESORE ME RRUGET DYTESORE DO TE VENDOSEN PANDUSET E TROTUAREVE

DETAJI I PRERJES SE RRUGES ME PANDUS Sh 1:15

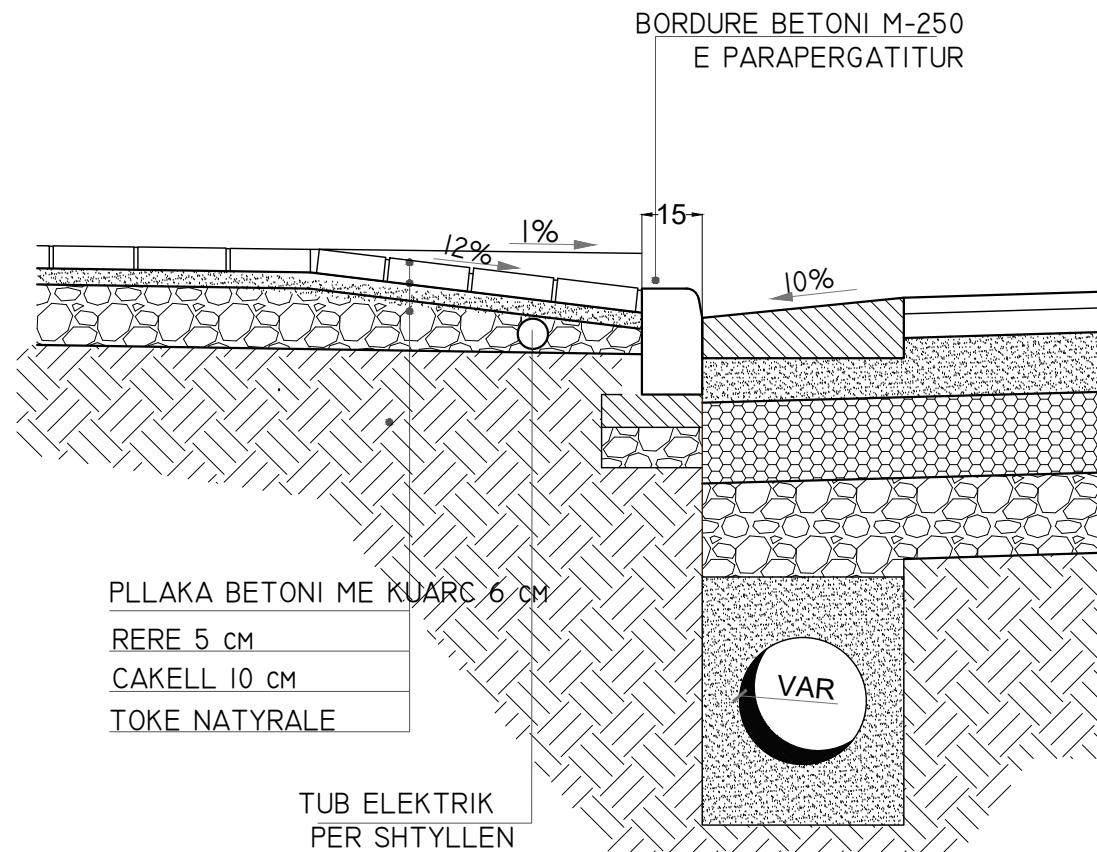

TUB ELEKTRIK
PER SHTYLLEN

Detaji i Bordurës dhe kunetes Sh 1:15

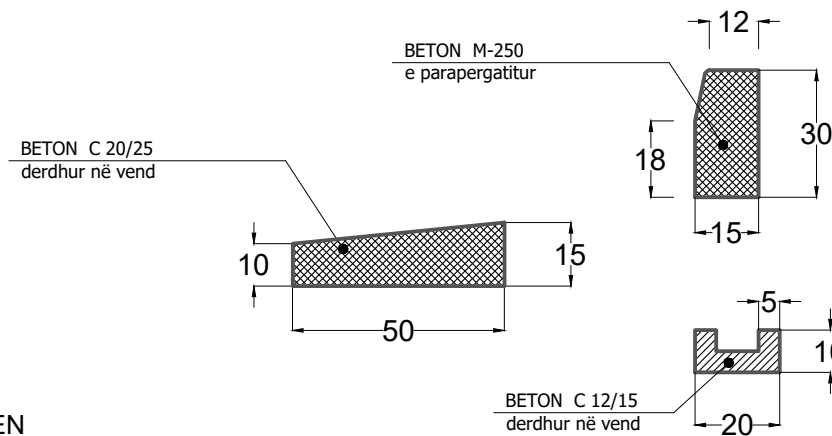

BASHKIA KAMEZ

DREJTORIA E SHERBIMEVE PUBLIKE
DREJTORIA E PROJEKTEVE DHE INVESTIMEVE
DEPARTAMENTI I PROJEKTEVE

Dr. e Projekteve e Investimeve	FLORA MUCA
--------------------------------	------------

STAFI TEKNIK PROJEKTES	Ing.	RAMADAN HYSA
	Ing.	ERBLIN LALA
	Ing.	DENIS PRENCI
	Ing.	NDERIM PASHA

Titulli i Projektit	Faza e Projektit
RIKONSTRUKSION RRUGA "LUNXHERI", NDERTIM RRUGA PARALEL ME RR "LUNXHERI", PINGUL ME RR "DURRESI", PINGUL ME RR "LURA", RRUGA "KORCE", MUR MBAJTES RRUGA "KOZAR"	PROJEKT ZBATIMI
Emertimi i Fletes	Data e Implementimit :
DETAJE	Shkalla e Vizatimit
	1:50
	Fiota Nr.
	02

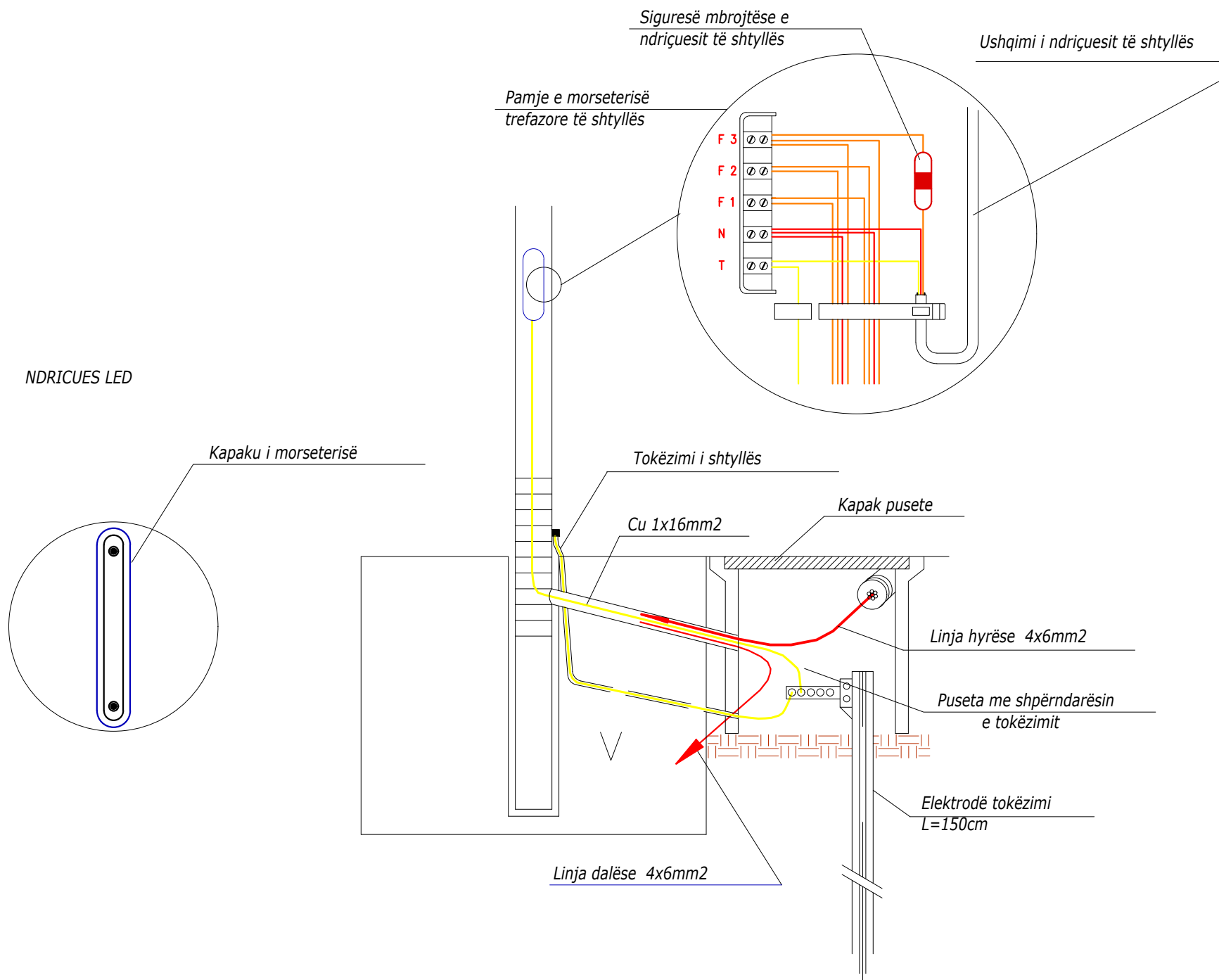
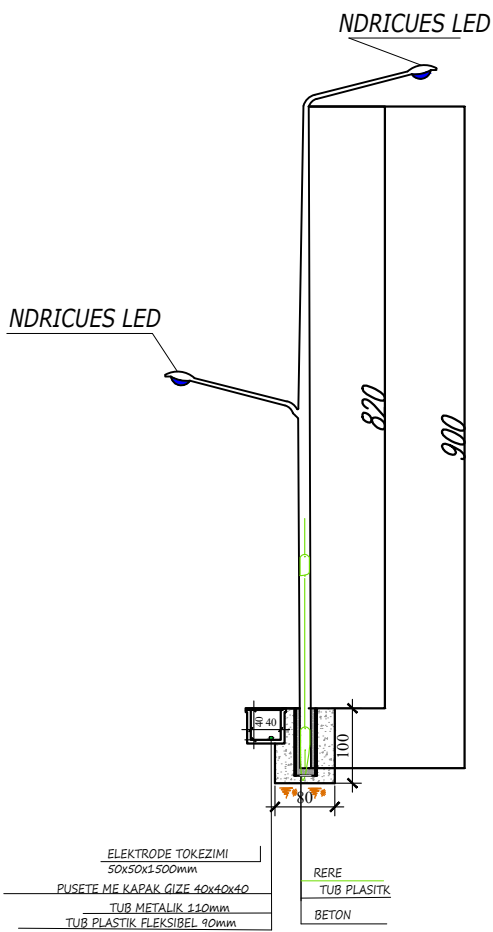

BASHKIA KAMEZ
 DREJTORIA E SHERBIMEVE PUBLIKE
 DREJTORIA E PROJEKTEVE DHE INVESTIMEVE
 DEPARTAMENTI I PROJEKTEVE

Dr. e Projekteve e Investimeve	FLORA MUCA
STAFI TEKNIK PROJEKTUES	Ing. RAMADAN HYSA Ing. ERBLIN LALA Ing. DENIS PRENCI Ing. NDERIM PASHA

Titulli i Projektit
 RIKONSTRUKSION RRUGA "LUNXHERI", NDERTIM RRUGA PARALEL ME RR "LUNXHERI", PINGUL ME RR "DURRESI", PINGUL ME RR "LURA", RRUGA "KORCE", MUR MBAJTES RRUGA "KOZAR"

Faza e Projektit
 PROJEKT ZBATIMI

Shkalla e Vizatimit
 1:50

Emertimi i Fletes
 DETAJE

Fleta Nr.
 03

Detaj i tokëzimit të shtyllës së ndriçimit

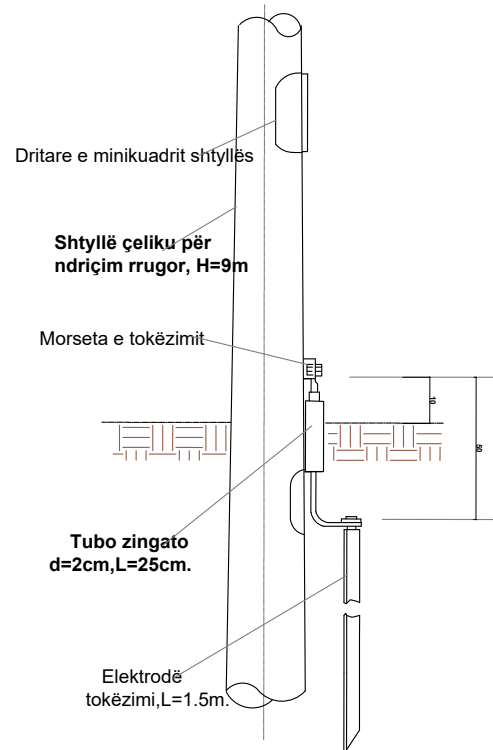

Konstruksioni morseterisë

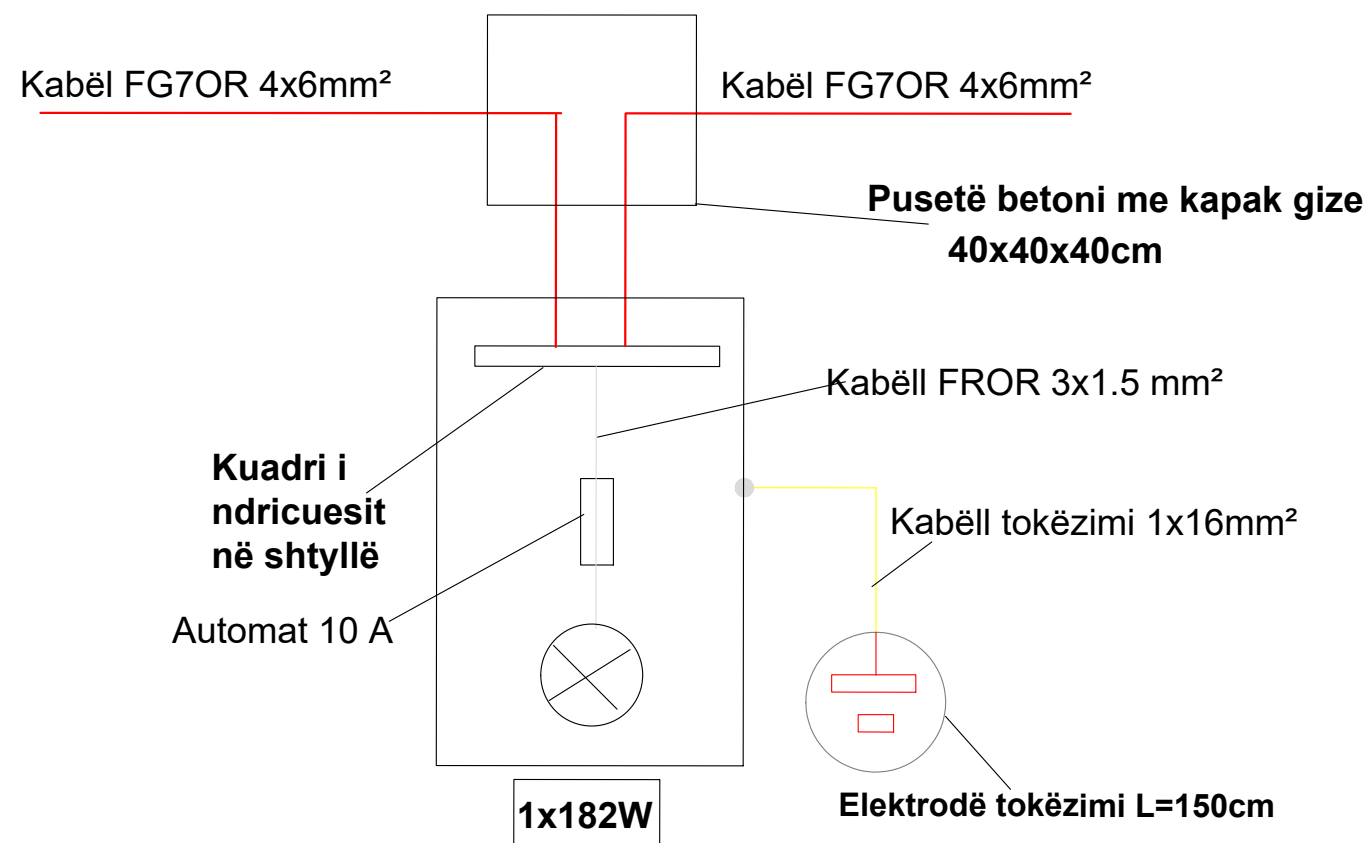
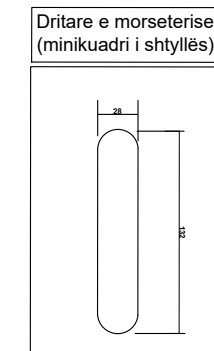
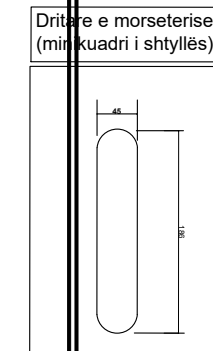
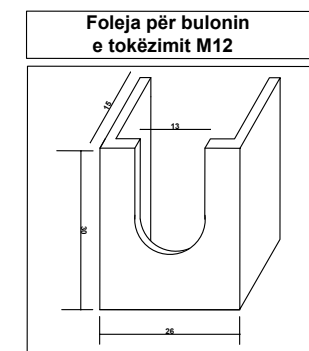
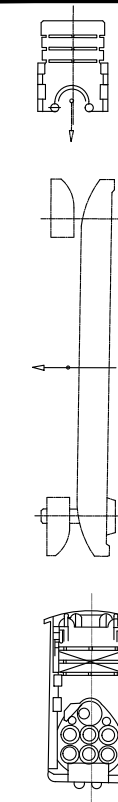
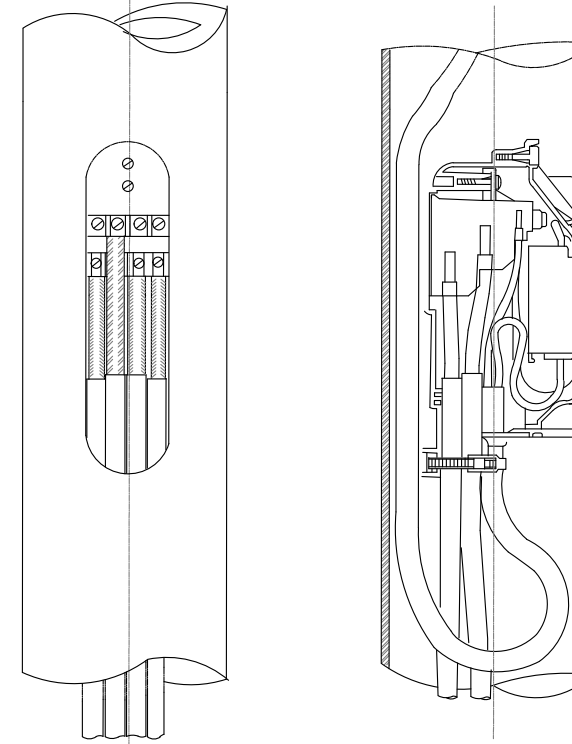

BASHKIA KAMEZ
 DREJTORIA E SHERBIMEVE PUBLIKE
 DREJTORIA E PROJEKTEVE DHE INVESTIMEVE
 DEPARTAMENTI I PROJEKTEVE

Dr. e Projekteve e Investimeve	FLORA MUCA
STAFI TEKNIK	Ing. RAMADAN HYSA
PROJEKTUES	Ing. ERBLIN LALA
	Ing. DENIS PRENCI
	Ing. NDERIM PASHA

Titulli i Projektit
 RIKONSTRUKSION RRUGA "LUNXHERI", NDERTIM RRUGA PARALEL ME RR "LUNXHERI", PINGUL ME RR "DURRESI", PINGUL ME RR "LURA", RRUGA "KORÇE", MUR MBAJTES RRUGA "KOZAR"

Faza e Projektit
 PROJEKT ZBATIMI

Data e Implementimit :

Shkalla e Vizatimit
 1:50

Fieta Nr.
 04

Emertimi i Fletes
 DETAJE

Hollësi e inkastrimit të kolonës së ndriçuesit me lartësi H=9m

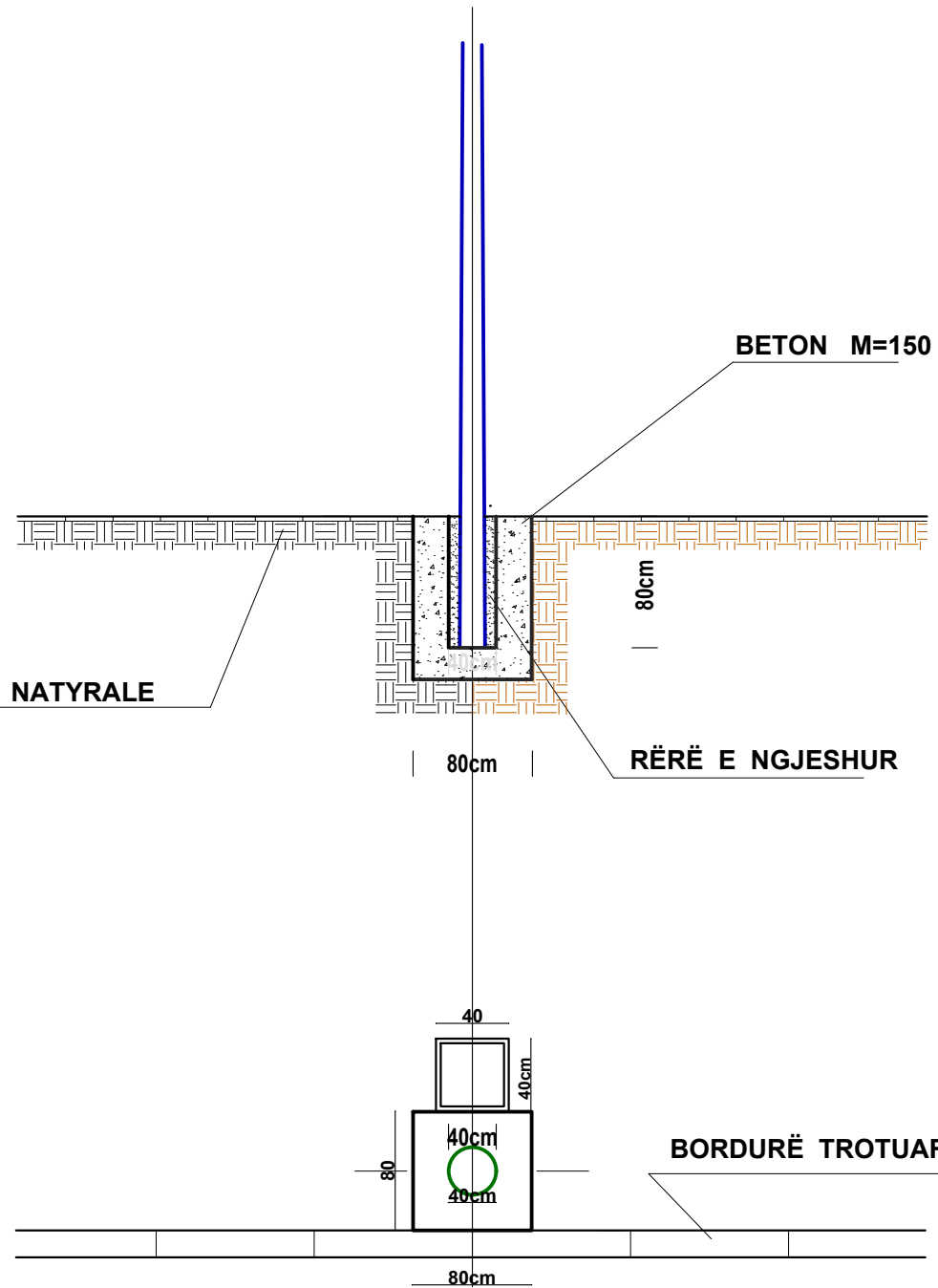

Hollësi e vendosjes së pusetës për Tub fleksibel 90mm

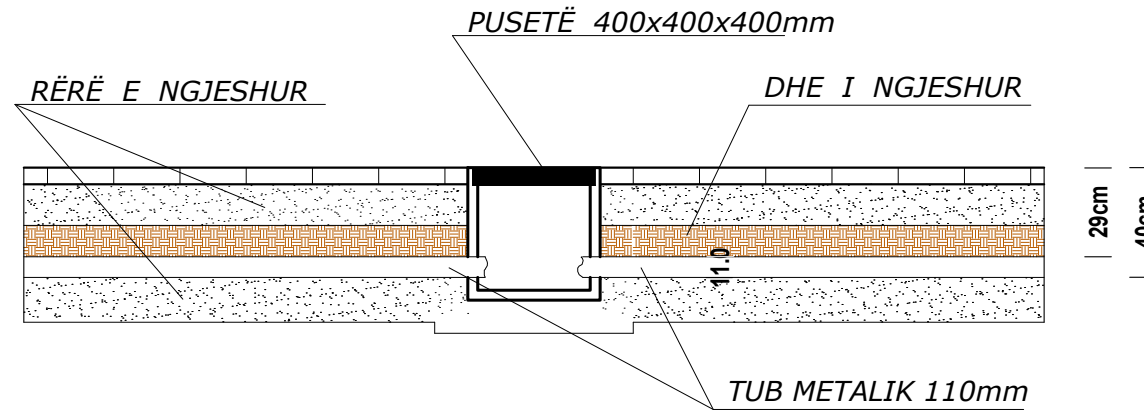

Hollësi e vendosjes së pusetës për Tub metalik 110mm

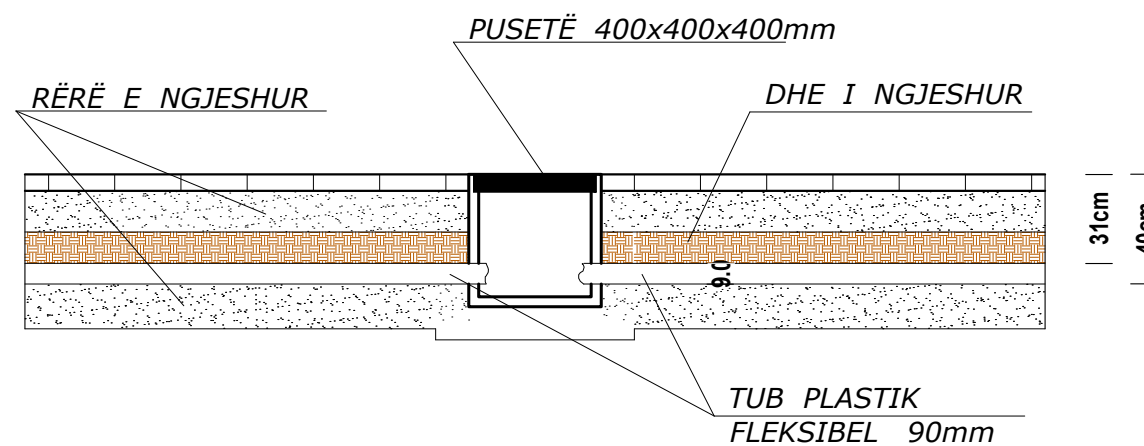

BASHKIA KAMEZ

DREJTORIA E SHERBIMEVE PUBLIKE
DREJTORIA E PROJEKTEVE DHE INVESTIMEVE
DEPARTAMENTI I PROJEKTEVE

Dr. e Projekteve e Investimeve	FLORA MUCA
--------------------------------	------------

STAFI TEKNIK PROJEKTES	Ing.	RAMADAN HYSA
	Ing.	ERBLIN LALA
	Ing.	DENIS PRENCI
	Ing.	NDERIM PASHA

Titulli i Projektit	Faza e Projektit
RIKONSTRUKSION RRUGA "LUNXHERI", NDERTIM RRUGA PARALEL ME RR "LUNXHERI", PINGUL ME RR "DURRESI", PINGUL ME RR "LURA", RRUGA "KORCE", MUR MBAJTES RRUGA "KOZAR"	PROJEKT ZBATIMI
Emeritimi i Fietes	Data e Implementimit :
DETAJE	Shkalla e Vizatimit 1:50
	Fleta Nr. 06

Planimetria e instalimit të rrjetit kabllor të ndriçimit,

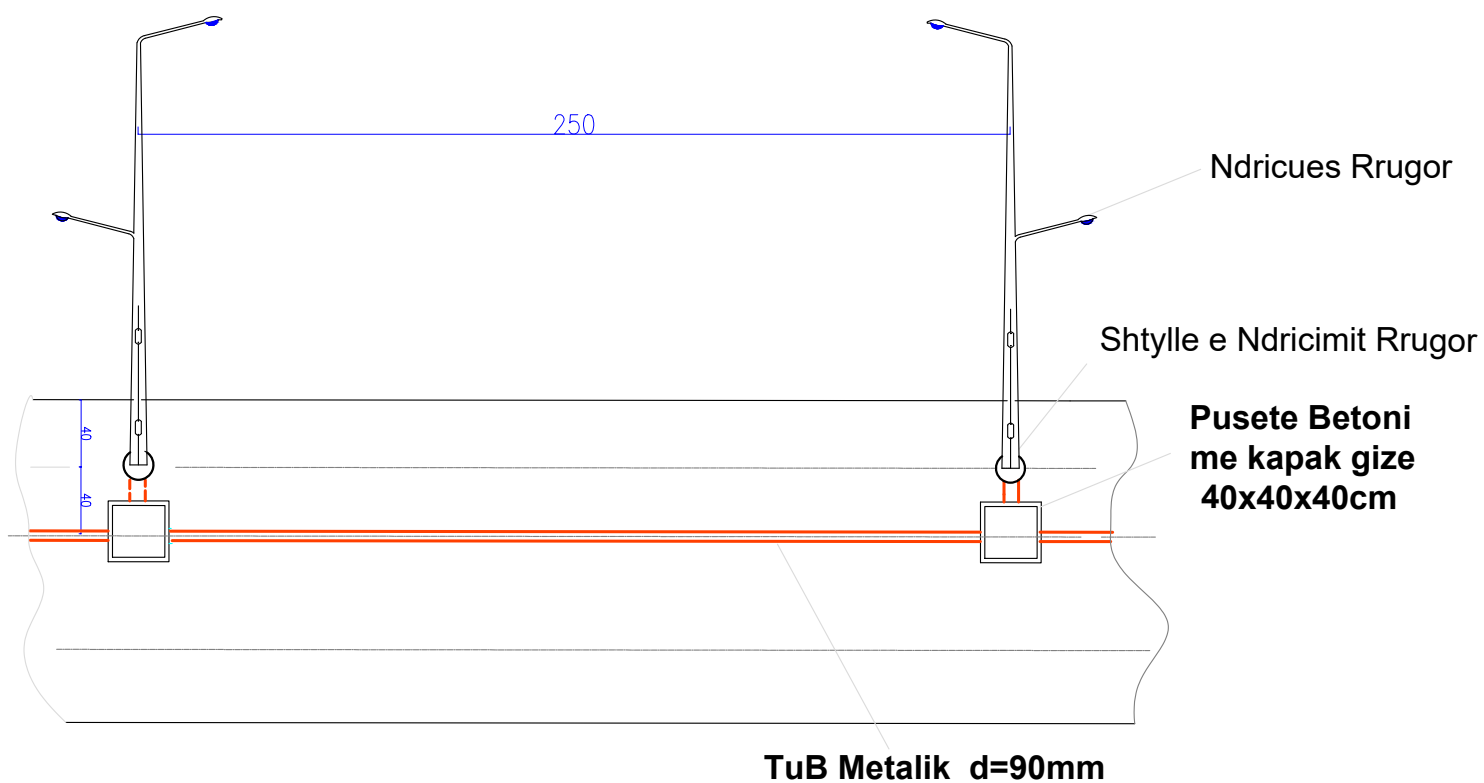

Shtrimi i kabllave te TU ne TP.direkt ne toke

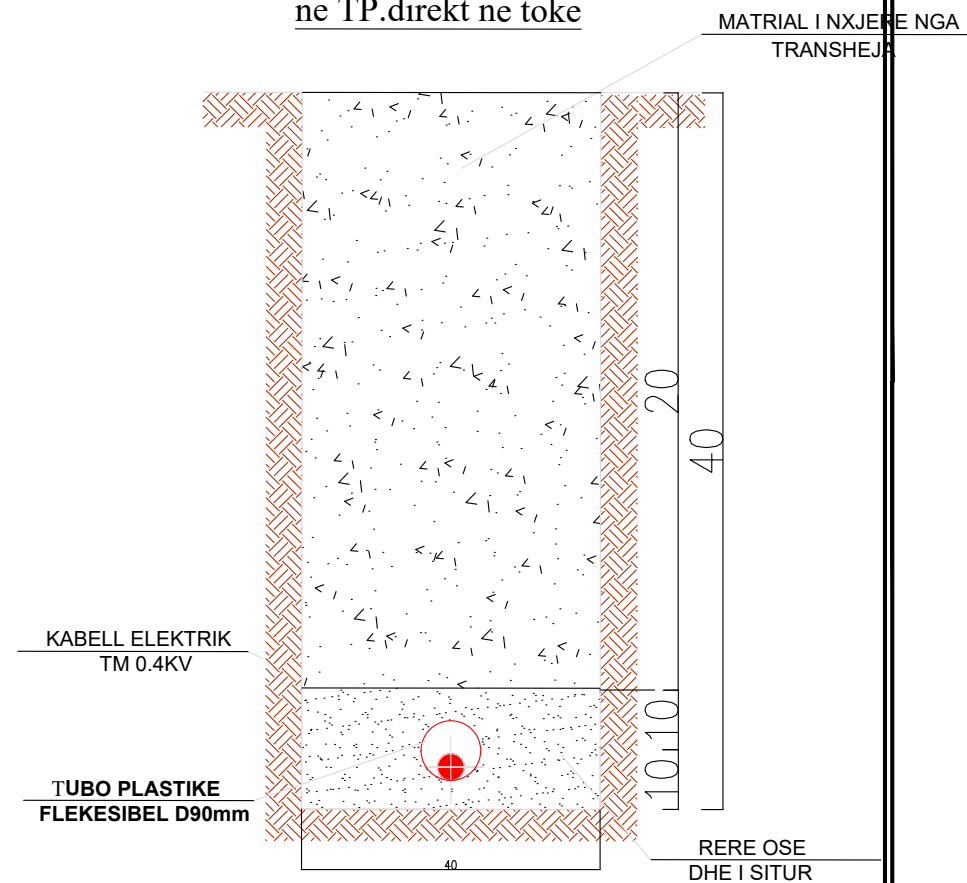

Detaj i montimit te pusetes dhe tokezimit te shtylles

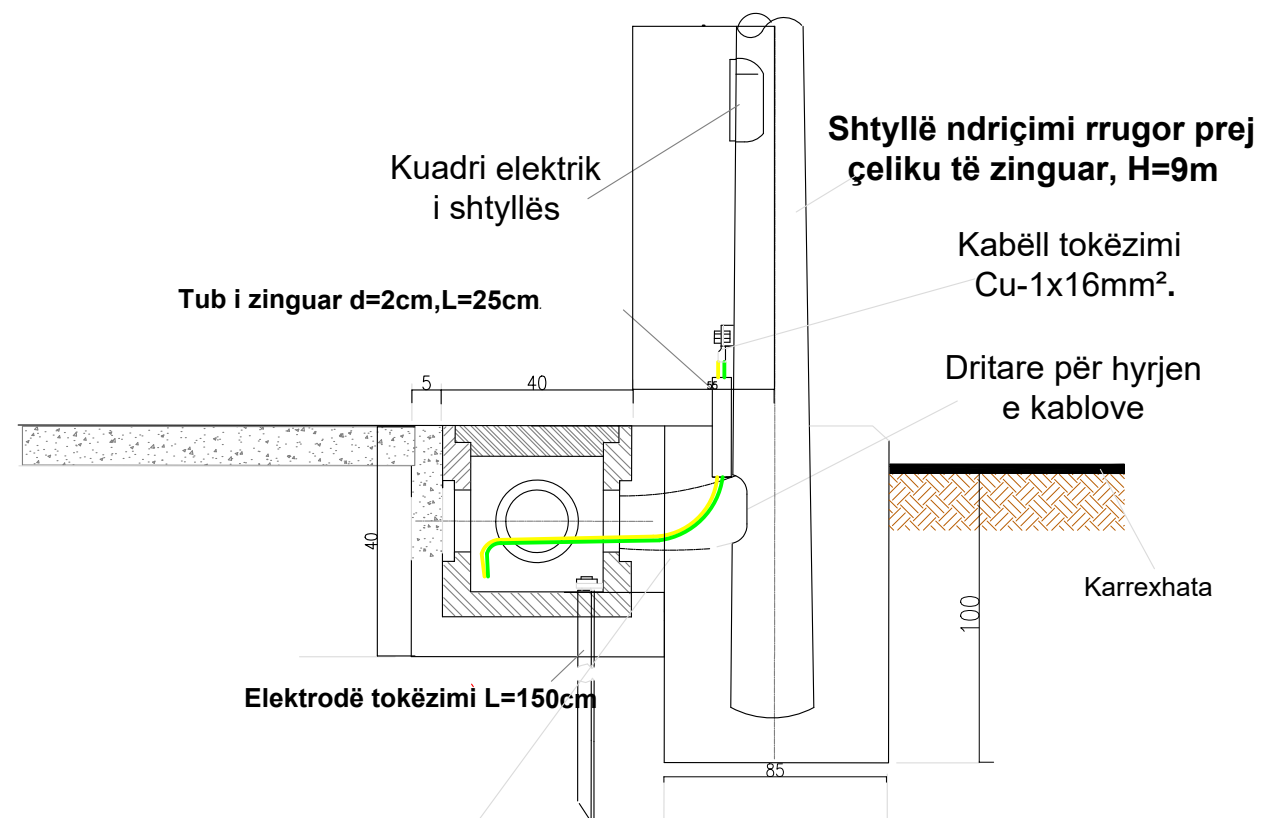

BASHKIA KAMEZ

DREJTORIA E SHERBIMEVE PUBLIKE
DREJTORIA E PROJEKTEVE DHE INVESTIMEVE
DEPARTAMENTI I PROJEKTEVE

Dr. e Projekteve e Investimeve		FLORA MUCA
STAFI TEKNIK PROJEKTES	Ing.	RAMADAN HYSA
	Ing.	ERBLIN LALA
	Ing.	DENIS PRENCI
	Ing.	NDERIM PASHA

Titulli i Projektit		Faza e Projektit
RIKONSTRUKSION RRUGA "LUNXHERI", NDERTIM RRUGA PARALEL ME RR "LUNXHERI", PINGUL ME RR "DURRESI", PINGUL ME RR "LURA", RRUGA "KORCE", MUR MBAJTES RRUGA "KOZAR"		PROJEKT ZBATIMI
Emertimi i Fietes		Data e Implementimit :
DETAJE		Shkalla e Vizatimit
		1:50
		Fleta Nr.
		07

VENDOSJA DHE MONTIMI I SHENJES RRUGORE

SHENJA LAJMERUESE

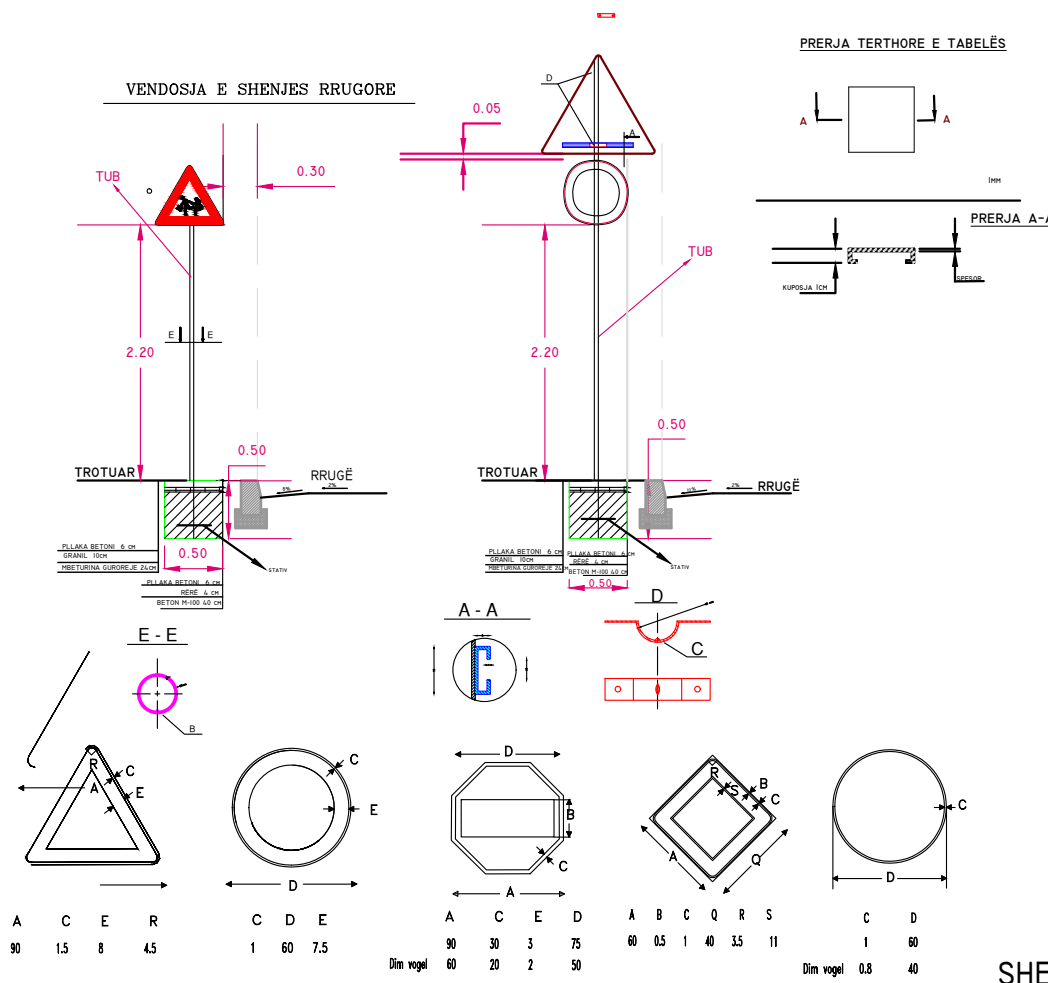

LAJMERIM PER NDERPRERJE NGA RRUGE DYTESORE, KTHESAT E KURBEZUARA, FEMIJET, KEMBESORET DHE PER NDALJE/DHENIE RRUGE

TREKENDESHI: E KUQE REFLEKTUESE
 SFONDI: I ZI
 SIMBOLI: E BARDHE REFLEKTUESE

TRIANGLE: RED REFLECTIVE
 BACKGROUND: WHITE REFLECTIVE
 SYMBOL: BLACK

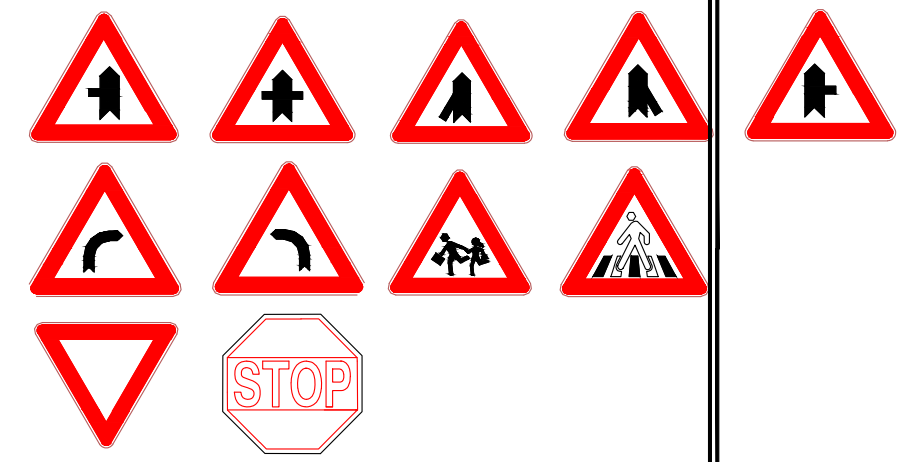

SHENJA NDALUESE

SHENJAT PER KUFIRIN E SHPEJTESISE DHE NDALIM PARAKALIMIN



SHENIM: SHENJAT RRUGORE PER NGA FORMA, MADHESIA, NGJYRA REFLEKTIVITETI DUHET TE JENE SIPAS KODIT RRUGOR TE REPUBLIKES SE SHQIPERISE MATERIALI PRAPAREFLEKTIV DUHET TE KETE JETEGJATESI 10VJET PER CLASIN 2 DHE 7 VJET PER CLASIN 1 SIMBOLI BRENDA SHENJES RRUGORE DUHET TE JETE I REALIZUAR ME BOJE TE TRAJTUAR ME PJEKJE E CILA NUK HUMBET TREGUESIT PRAPAREFLEKTIV SHENJA RRUGORE REALIZOHET ME LLAMARINE ÇELIKU E CILA LYHET ME BOJE OPAKE KUNDRANDRA KOROZIONIT DHE TRAJTOHET ME PJEKJE.

DETAJE Kurrizë artificiale h=5cm

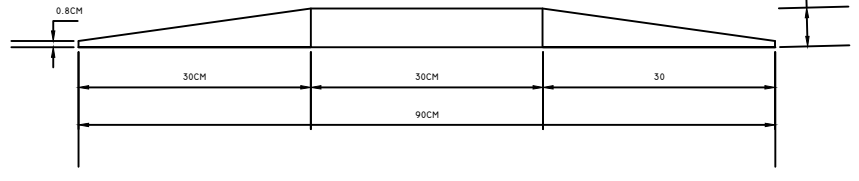

SHENJA DETYRUESE

ANET & SHIGJETAT: E BARDHE REFLEKTUESE
 EDGE & ARROW: WHITE REFLECTIVE

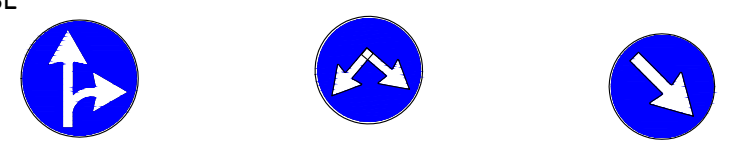

SHENJA PLOTESUESE

SHENJA E KTHESES NE NJE DREJTIM & DY DREJTIME

SHENJA : E BARDHE REFLEKTUESE
 SFONDI: E ZEZE

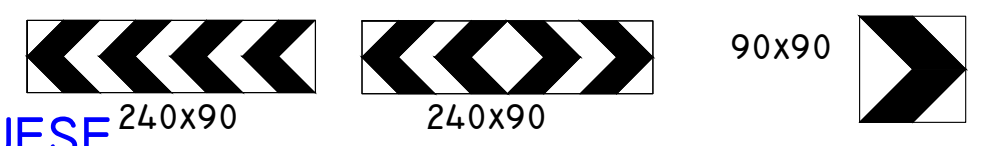

SHENJA INFORMUESE

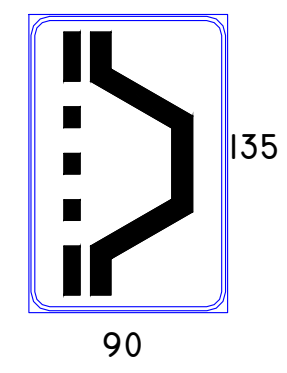

BASHKIA KAMEZ
 DREJTORIA E SHERBIMEVE PUBLIKE
 DREJTORIA E PROJEKTEVE DHE INVESTIMEVE
 DEPARTAMENTI I PROJEKTEVE

Dr. e Projekteve e Investimeve		FLORA MUCA
STAFI TEKNIK PROJEKTES	Ing.	RAMADAN HYSA
	Ing.	ERBLIN LALA
	Ing.	DENIS PRENCI
	Ing.	NDERIM PASHA

Titulli i Projektit NDERTIM RRUGET RIKONSTRUKSION RRUGA "LUNXHERI", NDERTIM RRUGA PARALEL ME RR "LUNXHERI", PINGUL ME RR "DURRESI", PINGUL ME RR "LURA", RRUGA "KORCE", MUR MBAJTES RRUGA "KOZAR" Emeritimi i Fletes	Faza e Projektit PROJEKT ZBATIMI Data e Implementimit:
DETAJE	Shkalla e Vizatimit 1:50 Fleta Nr. 08

PUSETE TIP D=100cm

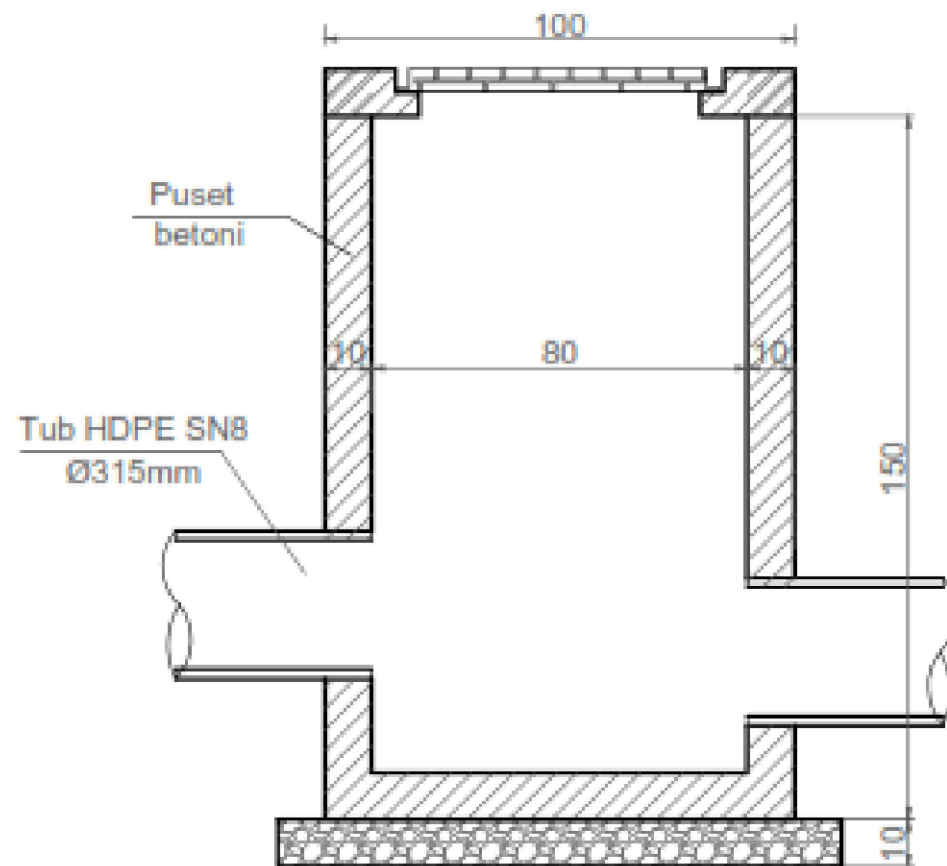
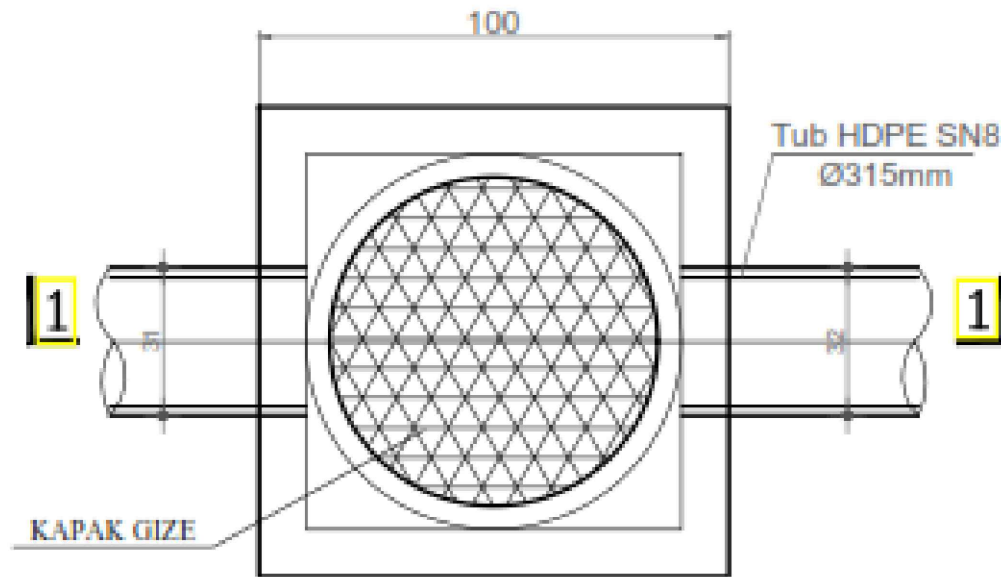

BASHKIA KAMEZ

DREJTORIA E SHERBIMEVE PUBLIKE
DREJTORIA E PROJEKTEVE DHE INVESTIMEVE
DEPARTAMENTI I PROJEKTEVE

Dr. e Projekteve e Investimeve FLORA MUCA

STAFI TEKNIK
PROJEKTUES
Ing. RAMADAN HYSA
Ing. ERBLIN LALA
Ing. DENIS PRENCI
Ing. NDERIM PASHA

Titulli i Projektit
RIKONSTRUKSION RRUGA "LUNXHERI", NDERTIM
RRUGA PARALEL ME RR "LUNXHERI", PINGUL ME
RR "DURRESI", PINGUL ME RR "LURA", RRUGA
"KORCE", MUR MBAJTES RRUGA "KOZAR"

Emertimi i Fletes
DETAJE

Faza e Projektit
PROJEKT ZBATIMI

Data e Implementimit:

Shkalla e Vizatimit:

1:50

Fleta Nr.

13